

# AGRICULTURAL MACHINERY AND MECHANIZATION



1. Engr. Prof. Dr. Muhammad Iqbal
2. Engr. Dr. Muhammad Azam Khan, Chairman and Associate Professor
3. Engr. Dr. Khawja Altaf Hussain (Associate Professor)

Department of Farm Machinery,  
Faculty of Agricultural Engineering & Technology  
University of Agriculture, Faisalabad,  
University of Agriculture, Faisalabad  
Pakistan

(2020)

## Table of Contents

Chapter	Title	Page
1	Farm mechanization	3
2	Sources of farm power	24
3	Engine & working principles	26
4	Basic terminology used for an engine	37
5	Internal combustion engine system	41
6	Fuel & fuel system	51
7	Engine cooling and lubrication systems	63
8	Tractor power transmission system	74
9	Land Development	84
10	Farm tractor	99
11	Estimating farm power & machinery costs	119
12	Tillage and its implements	123
13	Secondary tillage	141
14	Sowing machinery	149
15	Interculture tools and implements	162
16	Plant protection equipment	170
17	Harvesting & threshing equipment	205
	References	214

## FARM MECHANIZATION

By

*Engr. Dr. Kh. Altaf Hussain, Subject Expert*  
*Engr. Prof. Dr. Muhammad Iqbal, Subject Expert*

### 1. Agricultural mechanization

It is the process of using agricultural machinery to mechanize agricultural work to increase the productivity of farm workers. Effective mechanization helps to increase production by the timeliness of agricultural operations with good quality. The energy requirements for seedbed preparation, cultivation and harvesting are so great that existing human and animal power is inadequate. Therefore, agricultural operations are carried out partially or sometimes completely neglected, resulting in a low yield due to poor growth or premature harvesting or both.

**1.1 Scope of Mechanization** – In Pakistan, the farmers have the lowest earnings per capita because of the low yield per unit area. The way out of this problem is farm mechanization as following:

- Introducing improved agricultural implements on small size holdings being operated by bullock power.
- Introducing small tractors, tractor-drawn machines and power tillers on medium land holdings.
- Introducing large size tractors and machines on large land holdings.

There is a positive correlation between application of improved technologies and the land productivity. The repair, maintenance and overhaul facilities for tractors and other machines are expanding with the expansion of rural electrification in the country. Drudgery and physical exertion are typical of much in agriculture today. The development of improved riding type animal drawn machines can improve the present condition, but they cannot be a substitute for the tractor-drawn machines. By using mechanical power, man will be able to control larger areas and as such his family members will get more free time. More power is essential in carrying out operations effectively at the right time and for changing the attitudes and uplifting the social status and dignity of those who work in agriculture. Required power can be achieved by:

- Improving bullock harness and hitches

- Developing and introducing small tractors
- Increasing the number of large horsepower tractors

## **1.2 History of Farm Mechanization**

**1.2.1 Tractor manufacturing industry** - Tractor manufacturing industry in Pakistan started with the establishment of Rana tractors (now Millat Tractors Limited in 1964 and an assembly plant was set up in 1967 to assemble tractors imported in semi-knocked down condition. Local manufacturing of the tractors under Government approved deletion program started in 1981 and five firms were licensed for the purpose. The manufacturers of Belarus, Ford and IMT tractors went out of business and now only two manufacturers are actively involved in local manufacturing of tractors. M/s Millat Tractors Ltd. Lahore and M/s Al-Ghazi Tractors Ltd. Dera Ghazi Khan are producing 8 models of tractors in the range of 50 to 85 hp. Both of the companies have well established manufacturing/assembling plants and network of distribution and after sale service throughout Punjab and Pakistan. M/s Millat Tractors Ltd. is producing 45,000 units annually while M/s Al-Ghazi tractors Ltd., has installed capacity of over 30,000 tractors on single shift basis. Besides these two major tractor manufacturers, few other manufacturers are also producing and marketing locally assembled and imported tractors on a limited scale.

**1.2.2 Agricultural implements and machinery manufacturing industry** -Agricultural implements and machinery manufacturing industry started with the establishment of Esakhel Estate Farm, KotSamaba, District Rahim Yar Khan during early 50's which played a vital role in promotion and dissemination of farm mechanization in Punjab by importing first tractor in the country during 1954 and establishing a manufacturing unit for production of implements for mechanized farming with the collaboration of John Deere from USA. The Esakhel Estate Farm provided training to farmers of the area and also provided repair and maintenance services for the tractors and implements. During 1959, there were only 15 farm machinery manufacturers in the country. The number increased to 500 in 1984. The increasing trend of manufacturers during the period of 1978 to 1984 was due to the liberal government policies such as rebate in import duty for raw materials and exemption of income tax (Khan and Farooq, 1993). However, a setback has been observed in this industry by closing/reducing production by medium sized manufacturers due to withdrawal of above government incentives. Local farm machinery industry is producing a wide range of farm machinery except for the complex one like

transplanters for vegetables and paddy, combine harvesters, sugarcane harvester, cotton picker, corn picker, fodder cutters cum choppers, balers for silage, hay balers, tedder rakes, mango pruner, carrot washer, fruit and vegetable grader etc.

**1.2.3 Farm Mechanization Research and Development** - Farm Mechanization Research and Development in Punjab started with the establishment of Agricultural Engineering Research Division at Faisalabad during 1964 which was later up-graded to the level of full institute in 1976 and was named as Agricultural Mechanization Research Institute (AMRI). Later in 1978, it established Agricultural Machinery Division (AMD) during 1978 which was later up-graded to the level of fully fledged institute and named as Farm machinery Institute (FMI) under the Pakistan Agriculture Research Council. Subsequently, Farm Mechanization Institute (FMI) was renamed as Agricultural and Biological Engineering Institute (ABEI). Both the institutes are actively involved in R&D for design and development, testing and evaluation and promotion of low cost and appropriate farm mechanization technologies. Beside R&D, these institutions also undertake test and evaluation of imported as well as locally produced farm machines for adaptation. Provision of technical assistance to local farm machinery industry and farmers is also responsibility of these institutions. Over the period of last 35 years, Agricultural Mechanization Research Institute (AMRI) has contributed in development and commercialization of several successful machines including wheat thresher, seed drill, multi-crop planter, groundnut digger, wheat straw chopper, Maize Sheller, rotary potato digger, weeding-interculture-earthing up tool bar, sugarcane planter, axial flow pump, rotary slasher, biogas plant, seed cleaner/grader, bed and furrow shaper/planter, bed and furrow interculture equipment, hand driller/single row planter and self propelled sprayer, granules applicator, sugarcane ratoon management machinery, multi-crop Sheller, and maize Sheller. Similarly, ABEI has contributed in mechanization through development of zero tillage drill, rice and sunflower threshers, pneumatic planter, conservation agricultural machinery like happy and rocket seeder, solar dryer for fruits and vegetables and fuel fired maize dryer.

**1.2.4 Agricultural Engineering Education in Pakistan** - Agricultural Mechanization was set up initially in 1958 in the Engineering College Workshop, University of Engineering & Technology (UET), Peshawar, NWFP, Pakistan and formal education in agricultural engineering was introduced in 1962. The Faculty of Agricultural Engineering & Technology was established in 1961 when the Punjab Agriculture College, Lyallpur was given the status of University of Agriculture, Lyallpur. The main objective of the Faculty was to train manpower to

cater the growing needs of mechanized farming in the province of Punjab, Pakistan. This faculty is one of the pioneer faculty of its nature in whole Pakistan. In Nov. 1961, a diploma class of agricultural engineering was first started to support Thal Development Authority (TDA) and agricultural engineering workshop which was substituted with a four years B.Sc. Agricultural Engineering degree program in 1963. The faculty comprises of 1) Department of Farm machinery & Power, 2) Department of Irrigation & Drainage, 3) Department of Structures & Environmental Engineering, 4) Department of Food Engineering, 5) Department of Energy Systems Engineering, 5) Department of Fibre and Textile Technology and 6) Water Management Research Centre (WMRC). The overall objective of the faculty is to train manpower through teaching and research in their respective domain. The faculty is very actively engaged in offering courses both at undergraduate and postgraduate level to produce the skilled manpower specialized in managing water resources, farm equipment, environment, food, energy and textile engineering and technologies. The faculty is playing a vital role to mechanize the agriculture of Punjab. The faculty has designed and developed agricultural machines like; Multi-crop reaper, Rotary pit digger for sugarcane planting, Multi-operational machine for one pass system, Biogas plants for operating tubewells, Potato Digger, Solar Energy for extraction of juice from medicinal plants, Designed and installed fixed focus Scheffler (10 m<sup>2</sup>) solar system for drying crops, distillation of essential oils, nuts roasting, Zone Disk Tiller Drill (Registered by GOP), University Boom Sprayer (Registered by GOP), University Boom Sprayer Test Bench (Registered by GOP), High efficiency irrigation systems etc. During 1977, B.Sc Agricultural Engineering was also started in Sindh Agriculture University, Tandojam. The BSc. engineering was also expanded and started at Baha-ud din Zakariya (BZU) University, Multan during 2004 and at PirMehr Ali Shah Arid Agriculture University, Rawalpindi in 2013.

**1.2.5 Machinery standardization and quality control**– Pakistan Standards Institution (PSI) i.e. Pakistan Standard and Quality Control Authority (PS&QCA) is the statutory body to formulate National Standards of Agricultural Machinery, equipment and implements. PSI in collaboration with AMRI and ABEI has approved several standards of Agricultural Machinery, Equipment and Implements and their components. Unfortunately, in the absence of any market force which is generated by end-users / farmers, the manufacturers have entered into negative competition to produce low quality machinery, equipment and implements. As a result of this trend, the pace of PSI work has been slowed down. In the developed World adaptation of the standards to produce quality equipment by the local industry is done on voluntary basis but, the

Agricultural Machinery, Equipment and Implements Manufacturing Industry in Pakistan has failed to come up to the expectations of their consumers. Government of the Punjab, Agriculture Department constituted a committee during December, 1998 to introduce standards of manufacturing for the production of quality machinery, equipment and implements with the TOR's 1) to examine the existing rules and regulations dealing with manufacturing of agricultural machinery and implements, 2) to propose whether any fresh legislation is required, 3) to draw upon action plan for proposed legislation. The committee, after doing necessary spade work, concluded that there is a need to formulate legislation. Accordingly, legislation was drafted and submitted to the Agriculture Department, but the government has no any set up to regulate the industry.

### **1.3 Strengths and weaknesses of the existing agricultural mechanization system**

Punjab despite having Pakistan's best alluvial soils, diversified weather conditions with most appropriate day night temperature conditions, is facing constraints like low growth rate, low productivity, high cost of production and post-harvest losses, poor quality of produce and exorbitantly high market costs. In spite of these constraints, Punjab's agriculture sector has lot of opportunities to become one of the leading exporters of fresh produce due to increase in demand as a result of increasing population and high cost of production. Besides having lot of strengths and opportunities, Punjab's agriculture suffers from a variety of weaknesses and threats. The production system of Punjab at present is supply based instead of demand driven which results in low prices especially during the peak season. On the other hand, the consumers pay high prices during the off season. This not only generates low return to farmers but the consumers also don't get the required quality and quantity of the produce for the price they pay. Farmers lack capacity and knowledge to produce as per market demand. Empowering farmers with the information and ability of producing as per market demand which can increase farmers' income, and increase consumers' satisfaction. As a result of these constraints, Punjab is not only losing national and international competitiveness but the farmers are also not getting proper return which in turn is resulting in low per capita consumption and high poverty in rural areas. The extent of low crop yield can be seen from Table- 1.1 & 1.2.

**Table-1.1. Yield of major crops of Pakistan compared with the World's highest yield**

Crop	World's Highest Yield (ton/ha)	Pakistan's yield (ton/ha)		Yield Gap (ton/ha)	Yield Gap (Times)
		Potential	Avg. 2011-12		
Wheat	France (7.50)	6.81	2.83	3.98	1.72
Seed Cotton	China (4.00)	4.33	2.19	2.14	2.02
Sugarcane	Egypt (120.00)	300.00	56.00	244.00	2.02
Maize	France (10.90)	10.20	3.81	5.39	1.71
Rice	USA (7.40)	5.15	2.04	3.11	1.66

Source: FAO Statistical yearbook 2012

**Table-1.2: Percent increase required to ensure food security by the year 2020**

Years	Population (Millions)	Wheat (000 tons)	Cotton (000 Bales)	Rice (000 tons)	Sugarcane (000 tons)
2000	1310.41	19024	10732	4803	43606
2006	156.77	23295	12856	5438	54742
2011	177.1	25213.8	11560.1	4823.3	55308.5
2020	210.12	29937	15707.3	6750.1	68238.4
<b>% increase in 2020 over 2011</b>	<b>19</b>	<b>19</b>	<b>36</b>	<b>40</b>	<b>23</b>

Source: National Institute of Population Studies, Planning Commission of Pakistan Economic Survey of Pakistan (various issues).

#### **1.4 Agricultural implements and machinery manufacturing industry**

**1.5.1 Land development and leveling machinery** - According to the Punjab Development Statistics (2011-12), about 3.88 million acres are lying as cultureable waste land which does not include rain fed cultivated area of Thal and Potohar zones. For development of cultureable waste land, tractor mounted front blade and bulldozers are commonly used. Tractor mounted front blades are available through private sector while bulldozers for land development are available from the public sector. The existing fleet of 338 bulldozers with the Punjab Agriculture Department is insufficient to convert 3.88 million acres of culture able waste land. It is estimated that with the present strength of bulldozers, it will take about 100 years to develop the entire cultureable waste land (GOP, 2014).

**1.5.2 Soil tillage implements** - Tillage is performed to destroy pests' shelters and to disrupt their lifecycles, aerate the soil, eradicate weeds, incorporate crop residue, manure, fertilizers and pre-emergence weedicides, and to make other farm cultural practices easier to undertake.

Tillage process is generally accomplished in two stages, namely, primary and secondary tillage. Chisel plow, M.B. plow and Disc plow are main types of primary tillage implements. Secondary tillage on the other hand is performed after primary tillage for lighter or finer operations. Disc harrows, cultivators, rotary tillers etc., are commonly used for this purpose. Planking is done to crush the hard clods and to smoothen surface soil and to compact the soil lightly. In Punjab, cultivator is the most widely used implement for primary as well as secondary tillage of soil. Repeated use of cultivator not only creates hardpan which adversely effects root development/penetration, but it does not fulfill the purpose of tillage. Most of the progressive farmers do use mould board plow and disc plow for primary tillage and disc harrow and rotary tiller for secondary tillage specially for sowing of wheat after paddy and cotton in Punjab. Conservation tillage practices such as zero tillage for sowing wheat in fields with rice stubbles, permanent beds tillage (for sowing of cotton on beds of previous crop) and mulch or stubble tillage (retention of previous crop stubbles in the field) are also practiced on limited scale not only to minimize cost of tillage and seedbed preparation, but also to mitigate greenhouse gases.

**1.5.3 Seedbed preparation implements** - After tillage, quality of seedbed plays an important role in crop yield. Sometimes, use of secondary tillage implements does not provide favorable conditions for seed germination and growth; therefore, seedbed preparation implements are used to provide soil aggregates of the proper size. Some of the seedbed preparation implements commonly used in Punjab include clod breaker, cultivator and planker. Use of rotary tiller and disc harrow for seedbed preparation is expanding.

**1.5.4 Seeding and planting machinery** - After proper seedbed, crop stand mainly depends upon proper seeding depth as too shallow seed is prone to birds attack while too deep seed may not germinate due to heavy load of soil on the seeds. For proper yield of any crop, plant population and row to row distance plays an important role which can only be achieved if appropriate sowing machines are used. Due to time limitation or high cost of tillage and seedbed preparation, some farmers spread seed through broadcasting which neither provides desired plant population nor results in proper yield.

For sowing of wheat, mostly seed drill with or without fertilizer attachment is commonly used in Barani as well as in irrigated areas of the Punjab. In fields containing stubbles of cotton, rice and sugarcane, coulter drills are used most effectively. In rice harvested fields, generally wheat seed drills are used after conventional methods of tillage and seedbed preparation which delays sowing by 3 to 4 weeks and results in lower yields. For timely sowing of wheat in manually

harvested rice fields, zero-tillage drill has been introduced. Another problem for sowing of wheat in combine harvested paddy fields is burning of rice straw as zero tillage or wheat seed fail to handle/manipulate heavy residue present in combine harvested fields. Bed and furrow system of sowing wheat on raised beds not only helps to save water but is particularly suitable for saline soils.

For sowing of row crops like cotton, maize, sunflower, groundnut and others, multi-crop planters are commonly used which don't place seeds at one place rather seed is more or less dropped in a continuous fashion which requires thinning of plants to maintain desired plant population. Use of such planters also requires more than recommended seed rate. In order to overcome this problem, pneumatic planters, inclined/vertical seed plate planters and are used in Punjab on a very limited scale. Pneumatic and inclined/vertical seed plate planters are capable to place one seed at the desired plant to plant distance. For these planters, seed germination rate must be almost 100%. Hill planting is a technique through which a bunch of 4-5 seeds is placed at one place. This technique is helpful in soils which tend to crust after rains or light irrigation. The collective force of emergence of several seeds placed at one spot ensures seed germination in such soils. In the absence of hill planting machine, seed placement is generally done manually.

For proper yield of rice crop, plant population plays an important role which is recommended to be a minimum of 100,000 per acre. Rice nursery transplanting in Punjab is generally done by skilled laborers which hardly transplant 50,000 to 60,000 plants per acre. For planting of sugarcane, sugarcane set planters are also used on a limited scale. In these planters, whole cane is fed vertically or horizontally while sets are cut automatically by the reciprocating blades. For sowing of potato seeds, vertical cup planters are commonly used.

**1.5.5 Weed control machinery and equipment** - According to field research conducted by the Adaptive Research Farms and AARI, weeds can reduce crop yield up to 40%. For mechanical control of weeds; in wheat sown on flat bed/land, bar harrows are used; in row crops like cotton and maize sown on flat bed, rigid tine interculture tools are used. For earthing-up and side dressing of fertilizers, fixed or expandable ridger wings are attached behind the rigid tines of the interculture tool bar. Sometime, rotary tillers are also used in place of rigid tines for weeding. For control of weeds in sugarcane crop, disc ratooners and rotary weeders are used. For chemical control of weeds, knapsack sprayers (manually operated and power operated) and tractor mounted boom sprayers are mostly used for application of pre as well as post emergence

weedicides. Some of the farmers sowing cotton and other crops on beds do apply pre-emergence weedicides through applicators provided with the bed and furrow planters.

**1.5.6 Fertilizer application machinery**-According to field trials conducted by the Adaptive Research Farms and AARI, fertilizer use efficiency is about 50% which is attributed to inappropriate application (broadcast) machinery and equipment. In Punjab, base fertilizers are generally applied through broadcast which is done manually or through tractor mounted fertilizer broadcaster. Fertilizers to be applied at the time of sowing are mostly applied through drills and planters while subsequent dose in wheat is applied through manual broadcast and in crops grown in rows is applied with the help of fertilizer attachment provided with the interculture tool. Some drills and planters do have provision for band placement of DAP fertilizer. Use of fertigation (applying of fertilizers through irrigation water) in drip irrigated crops is also being used. Some of the progressive farmers do apply fertilizers through foliar application.

**1.5.7 Pesticides application machinery** - According to field trials conducted by the Cotton Research Institute of PCC Multan, pesticides application efficiency is hardly 50% which has been attributed to use of inappropriate and poor quality of spray machinery and inadequate application methods. In Punjab, pesticides spraying is done using knapsack sprayers, tractor operated sprayers and hand held sprayers. Tractor operated sprayers used in Punjab are mostly of boom type for field crops while canon type mist blowers are also used for orchards. On a very limited scale hand held ULV sprayers are also used. The booms of tractor mounted sprayers are generally rigid which tend to sag which result in non-uniform application.

**1.5.8 Irrigation machinery** - According to the data provided by the Water Management Wing, water use efficiency (WUE) in Pakistan is lowest in the World (in wheat is 10% of China and in rice it is hardly 5% of Philippines). For irrigation purpose, where canal irrigation is either not available or where it is deficient, tube wells are used for supplementing canal supplies. In riverine areas where water table is within 30 ft, for lifting of water, centrifugal pumps are used, for lifting of water from depths of 30 to 100 ft, turbine pumps are used and for lifting of water from depths of 100 to 200 ft, submersible pumps are commonly used. In hilly areas, some farmers are using jack pumps which have the capability of lifting water beyond 500 ft.

**1.5.9 Harvesting and Threshing Machinery** - Harvesting losses due to delayed harvesting as well as use of inappropriate harvesting machinery of wheat, rice and other oilseed crops has been estimated to be around 10-15%.

Harvesting of wheat and rice is conventionally done using hand sickles. Tractor mounted reaper windrowers and combine harvesters are also used to a greater extent. Harvesting of rice done with wheat combines causes excessive grain losses and internal grain injury and hence reduces head rice recovery and increased grain breakage during milling. Threshing of wheat is mostly done with the help of stationary threshers which are powered through tractor PTO, engine or electric motors. The commercially produced wheat threshers are although of high output capacity but are heavy in weight and thus costly, energy inefficient, ergonomically unsafe. Threshing of basmati rice is generally done manually, but on a very limited scale head feeding type threshers are also used. For threshing of coarse grain rice, whole crop threshers are also available. For threshing of chickpeas, wheat thresher is used after incorporating proper size sieves and adjusting speed of threshing drum and blower but the quality of threshed produce is poor.

Harvesting of non-cereal crops like cotton, maize, sunflower, canola and rapeseed/mustard, groundnut and sugarcane is mostly done manually, but sometimes machines are also used. Cotton picking mechanization is perhaps the most expensive operation of harvesting any crop, as cost of commercially available cotton pickers is in the range of Rs. 15-20 million for a 2 row machine and over 25-30 million for a 4 row machine. Some efforts were made in the past to introduce US made IH and JD cotton pickers of horizontal spindle types, and a vertical spindle harvester from Uzbekistan, but due to exorbitantly high cost of picking, these machines could not meet success. The low cost tractor mounted version of cotton picking machine can be produced locally by establishing proper rebuilding facilities which is expected to cost 2-2.5 million for a single row machine and 3-4 million for a two row machine. Maize and sunflower is harvested with combine harvesters fitted with sunflower and maize headers. Similarly canola and rapeseed/mustard crops are also harvested with wheat combine harvesters. In the absence of headers, the combine harvesters are used as stationary thresher to thresh sunflower heads after 1-2 days of sun drying in the field. For harvesting of groundnut crop, groundnut diggers are also used. Similarly, sugarcane billet harvesters are also used. For threshing of oilseed crops like canola, rapeseed/mustard, wheat thresher is used after incorporating proper size sieves and adjusting speed of threshing drum and blower but the quality of threshed produce is poor. For shelling of groundnut and maize, shellers are used. The level of mechanization of different farm operations, increase in agricultural machinery and equipment and number of tube wells and tractors is shown in Table-1.3, 1.4 and 1.5 respectively.

**Table- 1.3 Estimated Levels of Mechanization of various Farm Operations (2010)**

<b>Farm Operation</b>	<b>Extent of Mechanization (%)</b>
Seedbed Preparation	85
Sowing/Planting	25
Weeding/Interculture	40
Spraying	95
Harvesting	40

*Source: Agricultural Statics of Pakistan*

**Table-1.4 Status and trend of selected implements and farm Machinery of Pakistan**

<b>Machinery</b>	<b>Year 1984</b>		<b>Year 1994</b>		<b>Year 2004*</b>		<b>Year 2010</b>	
	<b>Total in Pakistan</b>	<b>Punjab</b>	<b>Total in Pakistan</b>	<b>Punjab</b>	<b>Total in Pakistan</b>	<b>Punjab</b>	<b>Total in Pakistan</b>	<b>Punjab</b>
Cultivator	146863	123755	236272	203444	369866	317506	-	-
MB Plow	7319	2780	28413	17980	40050	27093	-	-
Disc Harrow	8140	2734	13233	8302	23764	16032	-	-
Ridger	4711	4030	10984	10872	71338	66806	-	-
Drill	11251	10669	64126	60835	70810	66700	295184	251112
Trolley	98787	81668	176412	145557	242655	195332	-	-
Thresher	78377	71195	112707	96655	137270	122737	353768	265546
Reaper	-	-	8073	-	13600	12528	66958	58099
Combine Harvester	-	-	359	-	3355	2899	29344	21369
Chisel Plow	712	-	6535	-	8514	6719	-	-
Rotavator	2101	-	5594	-	47919	44192	-	-
Cutter Binder		-		-		436	-	1770
Blades	69004	-	164489	-	233126	189965	-	-
Sprayers	-	-	20778	-	21756	20976	1438991	1121110
laser Leveler	-	-	-	-	2785	1692	-	4843

*Source: Census of Agriculture Machinery, 2004*

**Table-1.5 Number of tube wells and tractors in Pakistan, 1996–2010**

<b>Year</b>	<b>Tube wells</b>	<b>Tractors</b>
Up to 2000-01	659,278	316,783
2001/02	707,273	352,137
2002/03	768,962	395,520

2003/04	950,144	431,579
2004/05	984,294	480,366
2005/06	999,569	537,354
2006/07	1,025,636	601,836
2007/08	1,016,125	664,348
2008/09	1,069,991	727,545
2009/10	1,070,375	811,191

*Source: Agricultural Statics of Pakistan*

Harvesting losses of fruits and vegetables have been estimated to be 40-45% due to unavailability of inadequate harvesting, handling, and post harvesting equipments. In order to minimize harvest losses, maintain quality and increase shelf life, pre-harvest preparation should be made timely which includes lining up sufficient labor, supplies (containers and packaging items) and ensuring that all the tools and harvesting equipment is available and is in operation. Harvesting of fruits and vegetables is mostly done manually by using some sort of harvesting aid like clippers, ladders, scissors, knives, snipers and secateurs.

On-farm processing is limited to the extent of washing, cleaning and bagging of fruits and vegetables and cleaning and grading of grains. Post harvest processing of grains is mostly done at the processing plants while it is done at the pack houses in case of fruits and vegetables.

## **1.6 Proposed agricultural mechanization strategies**

According to FAO (1997), an agricultural mechanization strategy (AMS) should create a policy, in which farmers and other stakeholders may have the choice of farm power and equipment suited to their needs. The proposed strategy may also facilitate for importation and domestic manufacture of tools, equipment and machinery, their repair and maintenance, relevant training and extension programs, and promotion of financing systems for the purchase of farm power and related machinery and implements.

**1.6.1 Farm power** - Based on estimated population of tractors in Punjab for the year 2012, is 415,000 and based on cultivated area of 30.78 million acres, there is one tractor for every 74 acres of cultivated area. Assuming 55 hp per tractor, available power is 0.74 hp/ac as against 1.0 hp/ac as recommended by FAO. In order to achieve FAO recommended power, the tractor population needs to be raised to 600,000 by the year 2015 that will require annual induction of at least 60,000 @ 10% deletion and non-agriculture use. In order to achieve the proposed target of tractor population, the installed capacity of the both manufacturers is more than enough to produce required number of tractors, because both of the manufacturers are operating on single shift basis.

**1.6.2 Zone wise agricultural machines / implements for crop production** - To solve the food security issues, the required zone wise agricultural machines / implements for crop production on priority basis have been given in Table 1.6.

**Table 1.6 Zone wise agricultural machines / implements for crop production**

Name of Implements				
<b>Cotton &amp; Wheat Zone</b>				
Multan, Bahawalnagar, D.G.Khan, Layyah, Vehari, Khanewal, Rajanpur, Muzaffargarh, Lodhran, Pakpattan, Bahawalpur and R.Y.Khan (12 Districts)	1	Laser leveler	14	Mango sprayer mounted type
	2	Disc harrow	15	Broad caster for fertilizer
	3	Rotavator	16	Reaper
	4	Cultivator	17	Wheat thresher
	5	Rabi drill	18	Combine Harvester (Imported)
	6	Kharif Drill	19	Fodder cutter cum chopper
	7	Fertilizer band placement drill	20	Wheat straw chopper
	8	Bed & furrow shapper planter	21	Seed grader / cleaner
	9	Precision planter (for Soyabean, Maize & Sunflower)	22	Post Hole Digger
	10	Cotton ridger with fertilizer	23	Mango Pruner
	11	Bed interculture equipment	24	Fruit picker
	12	Boom sprayer (Tractor Mounted)	25	Sunflower thresher
	13	Knapsack Sprayer		
<b>Rice &amp; Wheat Zone</b>				
Sheikhupura, Hafizabad, Gujranwala, Nankana Sahib, Narowal, M.B.Din, Sialkot and Gujrat (8 Districts)	1	Laser leveler	10	Reaper
	2	Disc harrow	11	Wheat thresher
	3	Rotavator	12	Rice Straw shredder
	4	Cultivator	13	Rice thresher
	5	Double coulter drill with fertilizer	14	Combine Harvester (Imported)
	6	Fertilizer Band placement drill	15	Fodder cutter cum chopper
	7	Bed & furrow drill (Wheat)	16	Wheat straw chopper
	8	Knapsack Sprayer	17	Seed grader / cleaner
	9	Broad caster for fertilizer		
<b>Mixed Zone</b>				
Jhang, Chiniot, Sargodha, Okara, Faisalabad, Kasur, Khushab, T.T.Singh, Sahiwal and Lahore (10 Districts)	1	Laser leveler	13	Wheat thresher
	2	Disc harrow	14	Combine Harvester (Imported)
	3	Rotavator	15	Fodder cutter cum chopper
	4	Cultivator	16	Reaper
	5	Double coulter drill with fertilizer	17	Wheat straw chopper
	6	Sugarcane Planter	18	Seed grader / cleaner
	7	Fertilizer Band placement drill	19	Post Hole Digger
	8	Sugarcane ridger	20	Sunflower thresher

	9	Precision planter (for Soyabean, Maize & Sunflower)	21	Knapsack Sprayer
	10	Citrus Sprayer	22	Broad caster for fertilizer
	11	Knapsack Sprayer		
	12	Broad caster for fertilizer		

**1.6.3 Post harvest machinery for value addition-** Much of the food grown at agricultural farms never makes it past the farm gate, contributing to food insecurity. Estimates of the post-harvest losses of fruits and vegetables in Pakistan from mishandling, spoilage and pest infestation are nearly 45-50 percent indicating one half of what is produced never reaches the consumer for whom it was grown, and the effort and money required to produce it are lost-forever. Fruit, vegetables and root crops are quickly perishable, and if care is not taken in post harvest activities like handling, grading, processing, packaging and transport, they will soon decay and become unfit for human consumption. Estimates of production losses in mangoes, dates, tomatoes, bananas, chilies and onion sometimes are estimated as high as 50 percent. Similarly post harvest losses in cereals 15-20 percent has been recorded. More than 6.5 million families consisting of 30-35 million people are involved in livestock farming. In rural areas, it complements agriculture income by converting crop residues, agriculture byproducts and wastes into milk, meat, wool, hair etc. There are 72 million and 39 million animals in Pakistan and Punjab respectively. There are about 785 million birds in poultry estates across the country. Per capita availability of meat is 12 kg, most of which is from buffalo and cattle. Meat sector in Pakistan is working on an informal basis from animal raising to meat selling. Animal traders purchase animals from the rural areas and sell them to the animal markets in the urban areas. Butchers purchase these animals from animal markets and slaughter them in the slaughterhouses. Butchers act as meat traders and dominate the meat market both in rural and urban areas. The animals sold in these markets are generally diseased and culled animals. Butchers/traders prefer to buy these cheap animals. Appropriate use of post harvest technologies including milk processing and animal slaughtering will minimize the post harvest losses, increase the market value, quality and food value of farm products and hence would help solving food security issues. Modern post harvest technologies widely used in developed countries cannot be applied quickly in Pakistan because these are sophisticated, expensive and too large for the small-scale farming systems of Pakistan. Moreover, some small-scale equipment manufacturers in countries like Europe and Japan is too expensive for a developing country like Pakistan. Therefore, following indigenous postharvest technologies be developed:

1. Product cleaning, washing, processing and grading/sorting technologies for cereals
2. Picking, handling, packaging and storing technologies for fruits and vegetables

3. Farm to market transports like mini trucks, pick up vans and farm trolleys with shock absorbing (leaf springs) mechanical parts to save the farm products from mechanical injury during transport.
4. TMR Wagon for fodder
5. Small scale milk pasteurization units
6. Small scale animal slaughtering centers
7. CA technologies

**1.6.4 Renewable energy technologies** - Energy plays a pivotal role in production and development process. The conventional sources of energy are gradually diminishing leading to unaffordable prices for consumers. Most of the farm activities are hindered due to non-availability of enough energy. The electricity shortfall 3000-5000 MW has resulted severe load shedding in the country and the only solution is the energy conservation, energy efficiency and utilization of renewable energy resources. Potential for different types of renewable energy resources exists in Punjab viz. biogas, biomass, solar (PV and thermal), micro-hydel/canal-fall, biodiesel production etc. The province has the potential to produce 674 MW electricity from animal dung of 39 million animals and 175 MW Power from droppings of 390 Million poultry birds. Moreover, the surplus 44 million tons per annum of biomass can produce 3300 MW (@ 0.667 kWh per kg biomass). Additionally, 30 large sugar Mills are producing 450 MW [@15 MW each mill]. Moreover, Punjab Province is lying in the solar belt having an average solar global insolation of 5–6 kWh m<sup>-2</sup> day<sup>-1</sup> which can effectively be utilized for electricity generation employing solar PV technologies. High solar irradiance in summer (1000 W m<sup>-2</sup>) can also be used for the value addition of different agricultural products employing solar dryers, solar roaster solar distillation systems etc.

University of Agriculture, Faisalabad has developed indigenized RE technologies viz. biogas energy (25 and 40 m<sup>3</sup> plants), solar thermal and PV technologies for rural community. For solving energy crises issues in the province, locally developed and promoted RE technologies are; 1) Biogas operated Tubewells 25 m<sup>3</sup> and 40 m<sup>3</sup> floating drum biogas plants to operate 0.75 cfs, 2) Solar drying for fruits, vegetables, medicinal plants and cereal crops, 3) Solar distillation system for the processing of medicinal plants, 4) Solar roasting machine for peanuts and groundnuts, 5) Solar cookers for community kitchen applications, 6) Standalone Solar PV System, 7) Biomass Gasifiers for Power Generation, 8) Biomass Boilers for Power Generation and 9) Energy Auditing system

**1.6.5 Sustainable delivery, associated support system and capacity building of technical manpower-** At present, farm mechanization is limited to crop production. Its scope needs to be expanded to introduce post harvest machinery for proper drying and storage of grains, and processing units for value addition to agriculture produce at the farm/village level. There is a great potential to export fruits and vegetables if efforts are made in proper curing/pre-cooling, sorting/grading and packaging of fruits and vegetables at the farm/community level.

Farm mechanization activities/issues are being tackled by various agencies/institutes but in isolation. For identification of mechanization needs and their solution with little duplication by the agencies involved, AMRI, ABEI, and UAF should jointly work to find priorities mechanization issues, and advise to government of their solutions to ensure their implementation.

The private sector should be persuaded to establish their own R&D to meet WTO obligation of product quality at competitive prices. They should be encouraged to recruit qualified and experienced Agricultural Engineers at their strength and allocate adequate percentage of their turnover for R&D work. The Government shall incentivize tax rebate in lieu of R&D spending as is done for other manufacturing/value addition industries.

The R&D/testing facilities of the public sector R&D institutes should also be upgraded to focus on market driven issues. The R&D institutes like AMRI, ABEI, and UAF (teaching and research) need to be strengthened.

Pakistan Agricultural Machinery and Implements Manufacturers Association (PAMIMA) needs to be encouraged to play its due role of upgrading manufacturers premises facilities, creating their own R&D and producing quality products at competitive prices to meet WTO challenges. It can play active role in establishing raw material banks and common facilities centers at various farm machinery manufacturing clusters. There is a good business opportunity in establishing central facilities of manufacturing of specialized/critical components like gears, sprockets, and fast wearing parts of soil-engaging implements which will promote quality of manufacturing besides creating additional job opportunities for skilled manpower.

Joint venture avenues for sophisticated and complex machinery components like discs for harrows and plows, vegetable and paddy transplanters, combine harvester, sugarcane harvester, cotton picker etc. need to be exploited with attractive government incentives in soft term loan, duty import structure and tax holidays. This will help in upgrading mechanization level, attract foreign investors and create more employment opportunities in this sector.

There is a great potential of increasing farm power level from 0.7 to 1.0 hp per acre as recommended by the FAO for developing countries. To meet this requirement, tractors production per annum needs to be at least doubles by the year 2020.

Farm machinery being an expensive input encourages setting up of rental service centers for their easy access. This will promote widespread use of implements for land preparation, seeding and planting/transplanting, spraying, harvesting and threshing, grading/packing and storage etc. To promote mechanized farming in the province and to ensure food security, farm machines, implements and tractors were provided to the farmers on cost sharing basis by Government of the Punjab, Agriculture Department during the last couple of decades which imparted positive impact on crop production and helped in timely completion of farm operations. This practice should be continued to attain the sustainable level of mechanization.

Technical manpower for mechanized farming including operators and mechanics of tractor and combine harvesters, tube wells and plant protection machinery and equipment, fabricators/manufacturers of agricultural machinery and implements and service providers for mechanized farming has got limited formal training and lack basic operational and maintenance skills. This is not only harmful for operators but also limit desired benefits of mechanization. There is a common complaint of poor quality of workmanship of the tractor and combine operators which is the root cause of lower land and labor productivity and increased cost of production. At present there are several institutions which are conducting formal as well as informal training of the farmers. Some of the institutions under provincial government are In-service agriculture training schools, Water Management training institute, PIAM, AMRI and RAEDC under Agriculture Department; 8 agricultural machinery training schools under TEVTA and a cooperative agriculture training institute Chak 5-Faiz (District Multan) under Cooperative Department. Similarly, all agriculture Universities and manufacturers of tractors are also conducting training programs. In spite of all this skill of the technical manpower is not up to the mark which can be attributed to the posting of unqualified and un-trained teaching staff, posting of departmental officers on punishment, non-provision of adequate resources etc. In order to obtain desired results, it is proposed that an Agricultural Technology Academy shall be established in Punjab by bringing all of the training institutions as mentioned above under the ambit of the proposed academy. It is also proposed that such academy shall be fully autonomous and the management and teachers shall be hired on market salaries. Government, PAMIMA and tractor manufacturers shall provide seed money so that the proposed academy

shall work on sustainable basis. The proposed academy shall have training centers at each District.

### **1.6.7 Taxes system and appropriate incentives for manufacturers and end-users -**

Pakistan has a long history of taxing agriculture under different heads. The tax structure of the country is comprised of three-tier system i.e. federal, provincial and local level. Short of GST, all taxes in agriculture are provincial taxes and are collected through the provincial system. The GST, a form of indirect tax is levied on producers but ultimately its burden goes on the shoulders of consumers/end users. In the current budget, the government of Pakistan has imposed 17% sales tax on agricultural machinery and pesticides while subsidies on agriculture have been withdrawn since number of years. Withholding tax on purchase has also been levied by the government @ 4%. On the import of pesticides income tax is collected @ of 5.5% at port. Custom duty is also paid by the imports of pesticides @ 0.87% part of total production in part of total production in barani areas. Aggregate tax becomes 23.37% which is being paid by the pesticides sector. While more than 21% tax is being paid by the agricultural implement's manufacturing sector. Because in addition to GST and withholding tax certain other types of taxes are also being paid by the manufactures e.g. education tax, professional tax, social security contribution etc. According to the report of the national taxation reform commission (1986) that agriculture sector bears the heaviest burden of indirect taxes, i.e. 42% of all indirect taxes although its share in GDP has dropped to 26%. Therefore, the agriculture sector's share of indirect taxes comes to 14.9% as against 14.4% for the non-agriculture sectors on per capita basis. Hence the poorest sector taxes the heaviest burden of taxes. It has further been added that there is no subsidy on pesticides, seeds, farm machinery. For rapid adoption of modern and innovative farm mechanization technologies, the end users i.e. farmers and the manufacturers shall be provided following incentives:

### 1.6.8

#### 1. Incentives for the Farmers

- Supply of selected precision agriculture machinery and equipment on cost sharing basis
- Provision of interest free short term loans
- Provision of R&D incentives

#### 2. Incentives for the manufacturers

- Refund of GST on implements and tractors after certified sales
- Reduced electricity tariff for tube wells
- Establishment of common facility centers and material banks

**1.6.9 Establishment of National Council** - Establishment of National Council for Agriculture Mechanization under the chairmanship of Federal Minister National Food Security and Research Islamabad is needed to achieve the envisioned targets in a befitting manner. The function of the council will be to take policy decisions, review and revise mechanization strategies, monitor the programs of provinces and pursue for support to the farmers, industry and international collaboration for introduction of new machines, technologies and support for private and public sector in the provinces vis-a-vis special packages for low mechanization areas, crops, ecological zones etc. This council may shall after every six months and shall be represented by the Ministries of Industries and Production, Finance, Provincial Agriculture Departments, experts of agriculture machinery research and farmers. A technical expert committee shall be constituted to support this apex forum on technical front and having membership from national and provincial agriculture machinery researchers, academia and progressive farmers.

**1.6.10 Establishment of Provincial Councils** - Establishment of Provincial Councils for Agriculture Mechanization in the provinces under the auspices of Provincial Ministers of Agriculture which should have the same functions as national council except international linkages, national level subsidies and implementation of national programs. Provincial council shall be assisted by Agriculture Mechanization Board headed by a Managing Director with fair representation from public and private sector and responsible for the planning and monitoring of agricultural mechanization program at the provincial level, oversee testing and training activities, collection and analysis of agricultural mechanization data, monitoring agricultural

mechanization program meant for testing, training, fabrication, establishment of standardization of machinery and legislation for authorization of machinery inspection, strengthening of agriculture machinery research institutes, training facilities and introduction of agriculture engineering extension. The board should have sufficient funds and autonomy and organize regular interaction between progressive farmers, experts, banks and industries and facilitate group visits by farmers and manufactures of farm machinery to national and international exhibitions.

Pakistan Standards Institution (PSI), Pakistan Standard and Quality Control Authority (PS&QCA) the statutory body, should formulate and implement National Standards of Agricultural Machinery, equipment and implements. PSI in collaboration with AMRI and ABEI should focus on the followings:

- Legislation to enforce standards for all implements and machines produced locally from soil management to harvesting and post
- Testing of locally produced and imported farm machines by an accredited agency and display of performance and valuation fact sheets by the manufactures for facilitating the buyers
- Hiring of qualified and experienced engineers by the manufacturers and developing in-house facilities to evaluate working of their products for performance and reliability;
- Registration of manufacturers with specialization in preparing different implements, spare parts etc.
- Preparation of instruction manuals for quality manufacturing from selection of steel for different implements for diverse soils and crops and for their products; and
- Providing incentives to the manufacturers on quality products like soft term loan and purchases by the government departments.

### 1.6.11 Road map for mechanizing Punjab

Table 1.7 Proposed Roadmap for mechanizing Punjab, Pakistan

S.No.	Issues	Actions	Responsibilities
1.	Lack of awareness about the impact of mechanization	Create awareness through electronic and print media	Public-private organization
2.	Lack of training and capacity building for	Training and certification as pre-requisite	UAF/R&D organizations

	skilled manpower		
3.	Lack of data bank on status of mechanization and demand driven technologies	Mapping of mechanization and list of demand driven – crop zone specific technologies	GOP
4.	Low availability of farm power (HP/ac)	Provide more tractors on subsidy	GOP/ Public-private partnership
5.	Lack of crop-specific machinery package	Development of mechanization for each crop zone	UAF/R&D organizations
6.	High cost of machines	Indigenization through Reverse Engineering	Public-private organization
7.	Poor quality of local material and machines	Legislation for standardization and certification	GOP
8.	Lack of access to advanced machinery	Service centers at village level with subsidies	Public-private organization
10.	Lack of R&D coordination and weak research-industry linkages	R&D organizations and industries, public-private partnership under one umbrella	GOP UAF R&D organizations Industries
10.	Lack of machines for small, medium and large farmers	Import of demand driven machines for reverse engineering	Public-private partnership
11.	Missing value addition facilities - low cost machines	Demonstration and training for value addition	Public-private partnership
12.	Health and safety hazards	Modifications for ensuring safety	Public-private partnership

**SOURCES OF FARM POWER**

*By*

*Engr. Dr. Kh. Altaf Hussain, Subject Expert*

The farm power for various agricultural operations has been classified as:

- Tractor work including seed bed preparation, cultivation, harvesting and transportation.
- Stationary work including silage cutting, feed grinding, threshing, winnowing and lifting of irrigation water.

These operations are done by different sources of power, namely human, animal, oil engine, tractor, power tiller, electricity and renewable energy (biogas, solar and wind).

**2.1 Human Power**

Human beings are the main source of power for operating small tools and implements. They are also employed for doing stationary work like threshing, winnowing, chaff cutting and lifting irrigation water.

On the average a man develops nearly 0.1hp. The operations like transplanting of paddy, weeding and inter-culture operations or harvesting of crops demand large number of human labor on each of the farms in the country. Such peaks have got to be managed if one desires to have high return from his enterprise. Generally, the peaks are managed as follows:

- Increasing the working hours.
- Extending the time period of operations.
- Adjusting the cropping pattern.
- Mechanizing the operations, wherever possible.
- Decreasing the intensity of some operations.

**2.2 Animal Power**

The most important source of power on the farm all over the world and particularly in Pakistan is animal. It is estimated that nearly 80 per cent of the total draft power used in agriculture throughout the world is still provided by animals, although the number of agricultural tractors has become double after every ten years since 1930. The average force a bullock can exert is nearly equal to one tenth of its body weight. But for a very short period, it can exert many more times the average force. Generally a medium size bullock can develop between 0.50 to 0.75 hp.

Thus the variation in power developed by animals is considerable. Animals can be a very cheap source of farm power if raised by the farmer himself. It becomes the most costly source if the animal has to be bought from outside.

### **2.3 Mechanical Power**

The third important source of farm power is mechanical power that is available through tractors and stationary engines. The efficiency of diesel engine varies between 32 and 38 per cent, whereas that of the petrol engine is in the range of 25 and 32 per cent. Presently, diesel engines and tractors have gained considerable popularity in agricultural operations. Small pumping sets within 3 to 10 hp range are very much in demand. Likewise, oil engines of low to medium speed developing about 14 to 20 hp are successfully used at farms.

### **2.4 Electrical Power**

Now-a-days electricity has become a very important source of power on farms. It is steadily becoming more and more available with the increase of various river valley projects and thermal stations. Besides this, the use of electric power in dairy industry, cold storage, fruit processing and cattle feed grinding has tremendously increased.

## ENGINE & WORKING PRINCIPLES

By

*Engr. Dr. Muhammad Azam Khan, Assoc. Professor*

*Engr. Prof. Dr. Muhammad Iqbal, Subject Expert*

### 3.1 Introduction

A heat engine is a machine, which converts heat energy into mechanical energy. The combustion of fuel such as petrol and diesel generates heat. This heat is supplied to a working substance at high temperature. By the expansion of this substance in suitable machines, heat energy is converted into useful work. Heat engines can be further divided into external combustion (EC) and internal combustion (IC). In a steam engine the combustion of fuel takes place outside the engine and the steam thus formed is used to run the engine. Thus, it is known as external combustion engine. In the case of internal combustion engine, the combustion of fuel takes place inside the engine cylinder itself.

The two distinct types of IC engines used:

- **Petrol IC Engine** - In this engine liquid fuel is atomized, vaporized and mixed with air in correct proportion before being taken to the engine cylinder through the intake manifolds. The ignition of the mixture is caused by an electric spark and is known as spark ignition.
- **Diesel IC Engine** - In this only the liquid fuel is injected in the cylinder under high pressure at the end of compression stroke of piston.

### 3.2 Constructional Features of Internal Combustion Engine

A brief description of engine parts is given below.

**1. Cylinder-** The cylinder of an IC engine constitutes the basic and supporting portion of the engine power unit. Its major function is to provide space in which the piston can operate to draw in the fuel mixture or air (depending upon spark ignition or compression ignition), compress it, allow it to expand and thus generate power. The cylinder is usually made of high-grade cast iron. In some cases, to give greater strength and wear resistance with less weight, chromium, nickel and molybdenum are added to the cast iron.

**2. Piston** - The piston of an engine is the first part to begin movement and to transmit power to the crankshaft as a result of the pressure and energy generated by the combustion of the fuel. The piston is closed at one end and open on the other end to permit direct attachment of the

connecting rod and its free action. The materials used for pistons are grey cast iron, cast steel and aluminum alloy. However, the modern trend is to use only aluminum alloy pistons in the tractor engine.

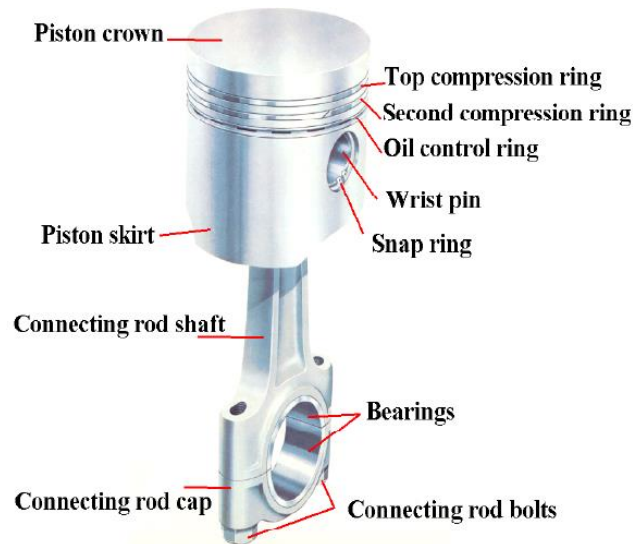

Figure 3.1 Piston and connecting rod

**3. Piston Rings** - These are made of cast iron on account of their ability to retain bearing qualities and elasticity indefinitely. The primary function of the piston rings is to retain compression and at the same time reduce the cylinder wall and piston wall contact area to a minimum, thus reducing friction losses and excessive wear. The other important functions of piston rings are the control of the lubricating oil, cylinder lubrication, and transmission of heat away from the piston and from the cylinder walls. Piston rings are classed as compression rings and oil rings depending on their function and location on the piston. Compression rings are usually plain one-piece rings and are always placed in the grooves nearest the piston head. Oil rings are grooved or slotted and are located either in the lowest groove above the piston pin or in a groove near the piston skirt. Their function is to control the distribution of the lubricating oil to the cylinder and piston surface in order to prevent unnecessary or excessive oil consumption.

**4. Piston Pin** - The connecting rod is connected to the piston through the piston pin. It is made of case hardened alloy steel with precision finish.

**5. Connecting Rod** - This is the connection between the piston and crankshaft. The end connecting the piston is known as small end and the other end is known as big end. The big end

has two halves of a bearing bolted together. The connecting rod is made of drop forged steel and the section is of the I-beam type.

**6. Crankshaft** - This is connected to the piston through the connecting rod and converts the linear motion of the piston into the rotational motion of the flywheel. The journals of the crankshaft are supported on main bearings, housed in the crankcase. Counter-weights and the flywheel bolted to the crankshaft help in the smooth running of the engine.

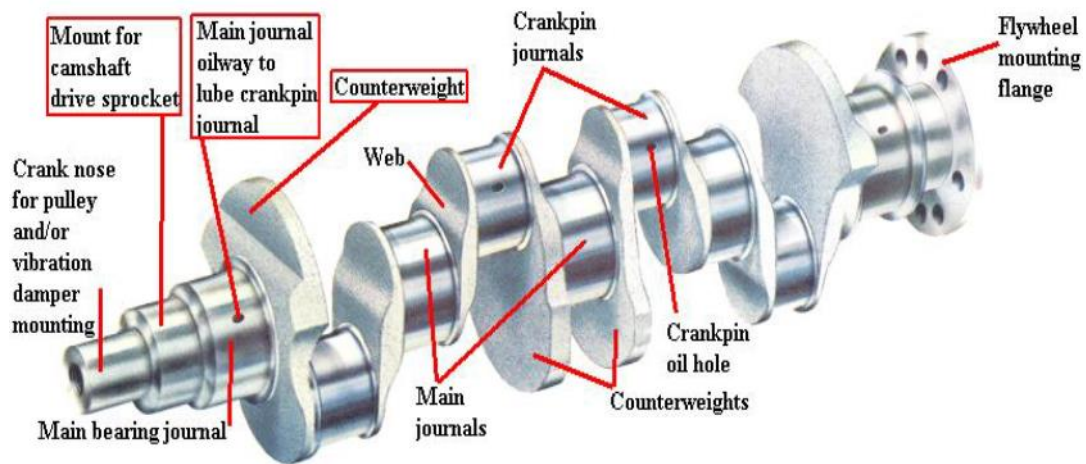

Figure 3.2 crankshaft

**7. Engine Bearings** - The crankshaft and camshaft are supported on anti-friction bearings. These bearings must be capable of withstanding high speed, heavy load and high temperatures. Normally, cadmium, silver or copper lead is coated on a steel back to give the above characteristics. For single cylinder vertical/horizontal engines, the present trend is to use ball bearings in place of main bearings of the thin shell type.

**8. Valves** - To allow the air to enter into the cylinder or the exhaust, gases to escape from the cylinder. Valves are provided, known as inlet and exhaust valves respectively. The valves are mounted either on the cylinder head or on the cylinder block.

**9. Camshaft** - The valves are operated by the action of the camshaft, which has separate cams for the inlet, and exhaust valves. The cam lifts the valve against the pressure of the spring and as soon as it changes position the spring closes the valve. The cam gets drive through either the gear or sprocket and chain system from the crankshaft. It rotates at half the speed of the camshaft.

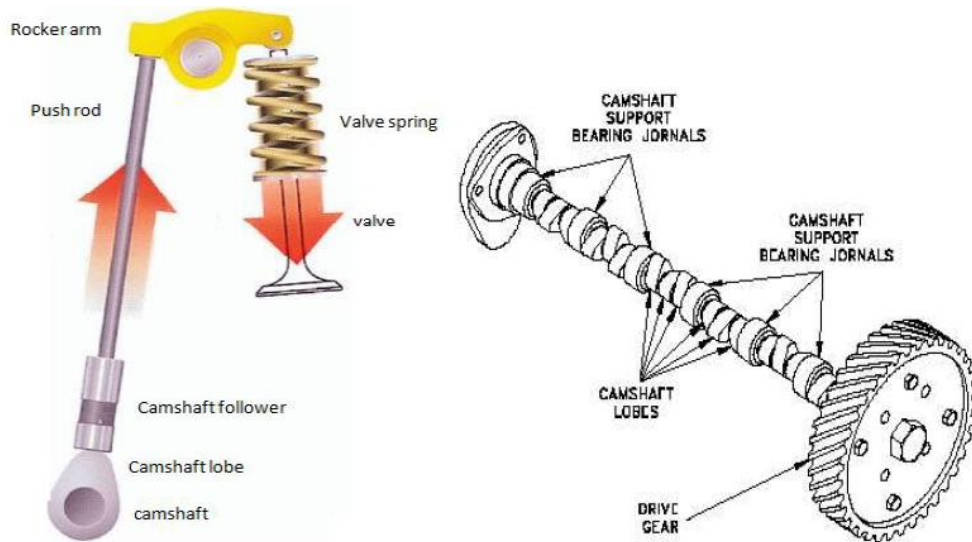

Figure 3.3 Valve system and camshaft

**10. Flywheel** - This is usually made of cast iron and its primary function is to maintain uniform engine speed by carrying the crankshaft through the intervals when it is not receiving power from a piston. The size of the flywheel varies with the number of cylinders and the type and size of the engine. It also helps in balancing rotating masses.

Cross section of a V-type four stroke cycle diesel engine and its parts has been presented in figure-3.4 and Table 3.1 respectively.

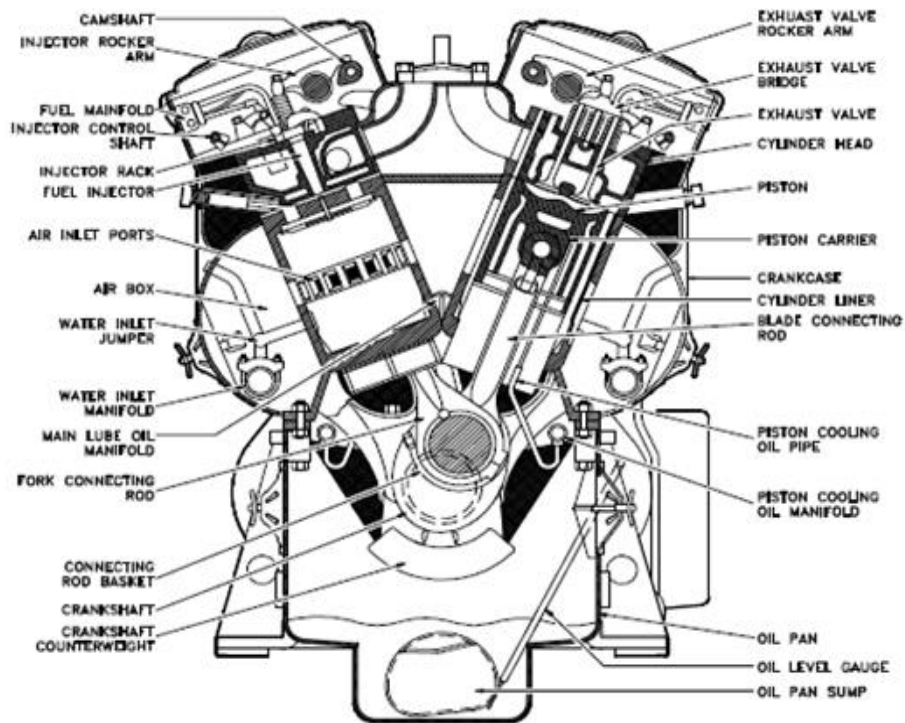

Figure 3.4 Cross section of a V-type four stroke cycle diesel engine

Table 3.1 Material of construction of engine parts

S. No	Part name	Material of construction
1	Cylinder head	Cast iron, Cast Aluminum
2	Cylinder liner	Cast steel, cast iron
3	Engine block	Cast iron, cast aluminum, welded steel
4	Piston	Cast iron, aluminum alloy
5	Piston pin	Forged steel, casehardened steel
6	Connecting rod	Forged steel, aluminum alloy
7	Piston rings	Cast iron, pressed steel alloy
8	Connecting rod bearings	Bronze, white metal
9	Main bearings	White metal, steel blocked Babbitt base
10	Crankshaft	Forged steel, cast steel
11	Camshaft	Forged steel, cast iron, cast steel
12	Timing gears	Cast iron, fiber, steel forging
13	Push rods	Forged steel
14	Engine valves	Forged steel, steel, alloy
15	Valve springs	Carbon spring steel
16	Manifolds	Cast iron, cast aluminum
17	Crankcase	Cast iron, welded steel
18	Flywheel	Cast iron
19	Studs and bolts	Carbon steel
20	Gaskets	Cork, copper, asbestos

### 3.3 Principles of operation of IC Engines

**3.3.1 Four-Stroke Cycle Diesel Engine** - In four-stroke cycle engines there are four strokes completing two revolutions of the crankshaft. These are respectively, the suction, compression, power and exhaust strokes (Figure 3,2).

**1. Suction stroke** -Piston descends on its suction stroke. Only pure air is drawn into the cylinder during this stroke through the inlet valve, whereas, the exhaust valve is closed. These valves can be operated by the cam, push rod and rocker arm.

**2. Compression stroke** - Piston moves up with both the valves remaining closed. The air drawn into the cylinder during the suction stroke is progressively compressed as the piston ascends. The compression ratio usually varies from 14:1 to 22:1. The pressure at the end of the compression stroke ranges from 30 to 45 kg/cm<sup>2</sup> (2943 to 4415 kPa). As the air is progressively compressed in the cylinder, its temperature increases, until when near the end of the compression stroke, it becomes sufficiently high (650-800 °C) to instantly ignite any fuel that is injected into the cylinder. When the piston is near the top of its compression stroke, a liquid hydrocarbon fuel, such as diesel oil, is sprayed into the combustion chamber under a pressure of

140-160 kg/cm<sup>2</sup> (13734 to 15696 kPa), higher than that existing in the cylinder itself. This fuel then ignites, being burnt with the oxygen of the highly compressed air. During the fuel injection period, the piston reaches the end of its compression stroke and commences to return on its third consecutive stroke.

**3. Power stroke** - During this stroke the hot products of combustion consisting of carbon dioxide (CO<sub>2</sub>), together with the nitrogen (N<sub>2</sub>) left from the compressed air expand, thus forcing the piston downward. This is only the working stroke of the cylinder. During the power stroke the pressure falls from its maximum combustion value (47-55 kg/cm<sup>2</sup> which is usually higher than the greater value of the compression pressure (45 kg/cm<sup>2</sup>) near the end of the stroke. The exhaust valve then opens, usually a little earlier than when the piston reaches its lowest point of travel.

**4. Exhaust stroke** - The exhaust gases are swept out on this upward stroke of the piston. The exhaust valve remains open throughout the whole stroke and closes at the top of the stroke.

The reciprocating motion of the piston is converted into the rotary motion of the crankshaft by means of a connecting rod and crankshaft. The crankshaft rotates in the main bearings, which are set in the crankcase. The flywheel is fitted on the crankshaft in order to smoothen out the uneven torque that is generated in the reciprocating engine.

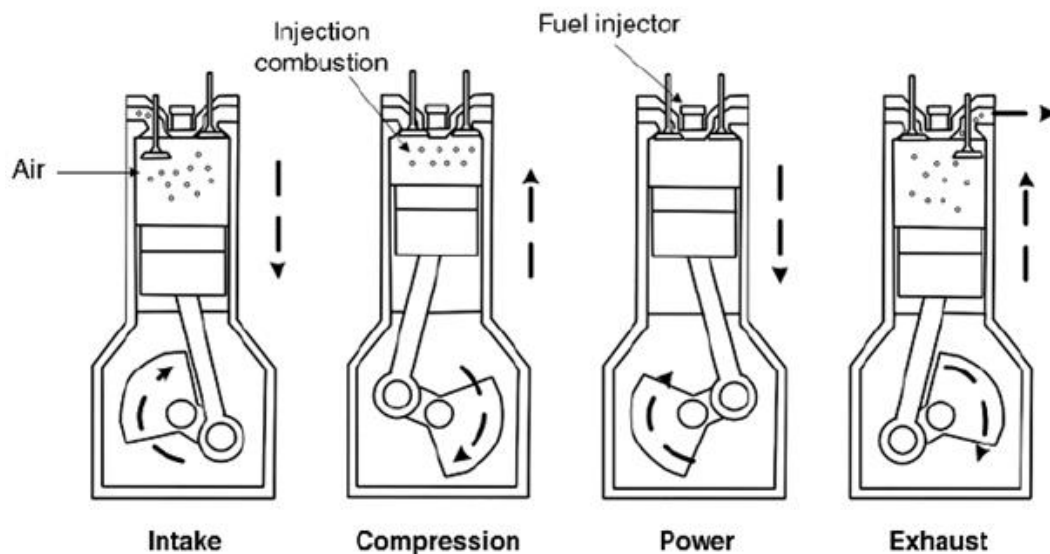

**Figure 3.5 Four-Stroke Cycle Diesel Engines**

### 3.3.2 Two-Stroke Cycle Diesel Engine

The cycle of the four-stroke of the piston (the suction, compression, power and exhaust strokes) is completed only in two strokes in the case of a two-stroke engine (Figure 3.3). The air is drawn into the crankcase due to the suction created by the upward stroke of the piston. On the down stroke of the piston it is compressed in the crankcase. The compression pressure is usually very low, being just sufficient to enable the air to flow into the cylinder through the transfer port when the piston reaches near the bottom of its down stroke. The air thus flows into the cylinder, where the piston compresses it as it ascends, till the piston is nearly at the top of its stroke. The compression pressure is increased sufficiently.

#### Modern Two-Stroke Cycle Diesel Engine

The crankcase method of air compression is unsatisfactory, as the exhaust gases do not escape the cylinder during port opening. Also there is a loss of air through the exhaust ports during the cylinder charging process. To overcome these disadvantages blowers are used to pre-compress the air. This pre-compressed air enters the cylinder through the port. An exhaust valve is also provided which opens mechanically just before the opening of the inlet ports.

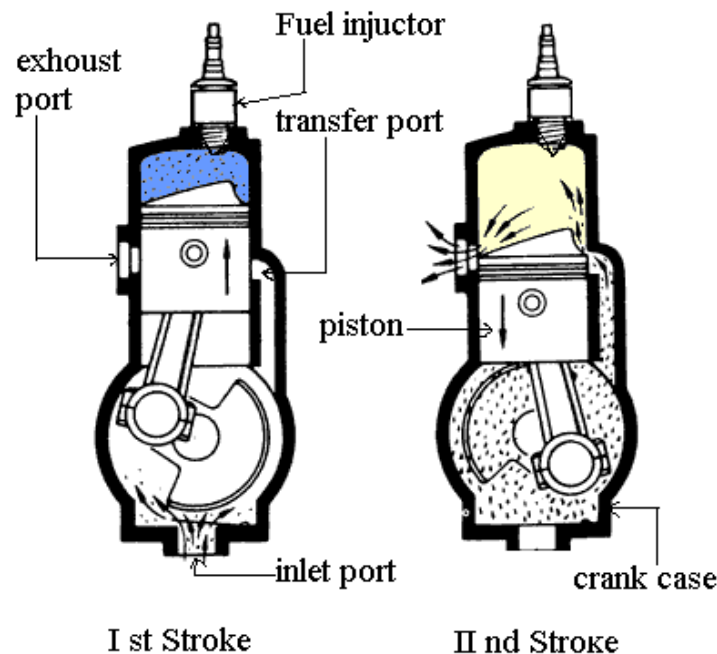
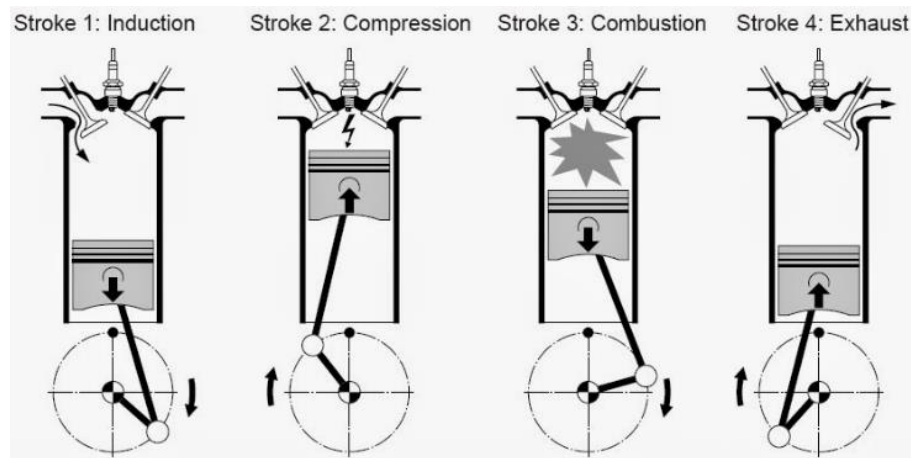

Figure 3.6 Two stroke cycle diesel engine

### 3.3.3 Four Stroke Spark Ignition Engine

In this gasoline is mixed with air, broken up into a mist and partially vaporized in a carburetor (Figure 3.4). The mixture is then sucked into the cylinder. There it is compressed by the upward movement of the piston and is ignited by an electric spark. When the mixture is burned, the resulting heat causes the gases to expand. The expanding gases exert a pressure on the piston (power stroke). The exhaust gases escape in the next upward movement of the piston. The strokes are similar to those of four-stroke diesel engines. The compression ratio varies from 4:1 to 8:1 and the air-fuel mixture from 10:1 to 20:1.



**Figure 3.7 Four Stroke Spark Ignition Engine**

### 3.3.4 Two-Stroke Cycle Petrol Engine

The two-cycle carburetor type engine makes use of an airtight crankcase for partially compressing the air-fuel mixture (Figure 3.5). As the piston travels down, the mixture previously drawn into the crankcase is partially compressed. As the piston nears the bottom of the stroke, it uncovers the exhaust and intake ports. The exhaust flows out, reducing the pressure in the cylinder. When the pressure in the combustion chamber is lower than the pressure in the crankcase through the port openings to the combustion chamber, the incoming mixture is deflected upward by a baffle on the piston. As the piston moves up, it compresses the mixture above and draws into the crankcase below a new air-fuel mixture. The two-stroke cycle engine can be easily identified by the air-fuel mixture valve attached to the crankcase and the exhaust Port located at the bottom of the cylinder.

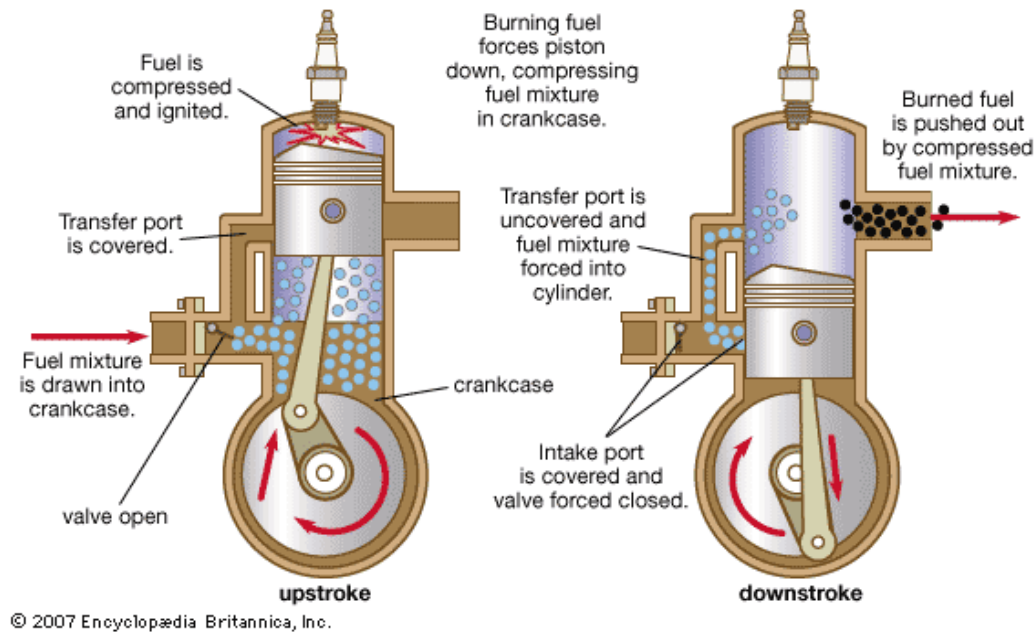

**Figure 3.8 Two stroke cycle petrol engine**

### 3.3.5 Comparison of Compression Ignition (CI) and Spark Ignition (SI) Engines

The CI engine has the following advantages over the SI engine.

1. Reliability of the CI engine is much higher than that of the SI engine. This is because in case of the failure of the battery, ignition or carburetor system, the SI engine cannot operate, whereas the CI engine, with a separate fuel injector for each cylinder, has less risk of failure.
2. The distribution of fuel to each cylinder is uniform as each of them has a separate injector, whereas in the SI engine the distribution of fuel mixture is not uniform, owing to the design of the single carburetor and the intake manifold.
3. Since the servicing period of the fuel injection system of CI engine is longer, its maintenance cost is less than that of the SI engine.
4. The expansion ratio of the CI engine is higher than that of the SI engine; therefore, the heat loss to the cylinder walls is less in the CI engine than that of the SI engine. Consequently, the cooling system of the CI engine can be of smaller dimensions.
5. The torque characteristics of the CI engine are more uniform which results in better top gear performance.
6. The CI engine can be switched over from part load to full load soon after starting from cold, whereas the SI engine requires warming up.
7. The fuel (diesel) for the CI engine is cheaper than the fuel (petrol) for SI engine.

8. The fire risk in the CI engine is minimized due to the absence of the ignition system.
10. On part load, the specific fuel consumption of the CI engine is low.

### **3.3.6 Advantages and disadvantages of two-stroke cycle over four-stroke cycle engines**

#### **a) Advantages**

1. The two-stroke cycle engine gives one working stroke for each revolution of the crankshaft. Hence theoretically the power developed for the same engine speed and cylinder volume is twice that of the four-stroke cycle engine, which gives only one working stroke for every two revolutions of the crankshaft. However, in practice, because of poor scavenging, only 50-60% extra power is developed.
2. Due to one working stroke for each revolution of the crankshaft, the turning moment on the crankshaft is more uniform. Therefore, a two-stroke engine requires a lighter flywheel.
3. The two-stroke engine is simpler in construction. The design of its ports is much simpler and their maintenance easier than that of the valve mechanism.
4. The power required overcoming frictional resistance of the suction and exhaust strokes is saved, resulting in some economy of fuel.
5. Owing to the absence of the cam, camshaft, rockers, etc. of the valve mechanism, the mechanical efficiency is higher. The two-stroke engine gives fewer oscillations.
6. For the same power, a two-stroke engine is more compact and requires less space than a four-stroke cycle engine. This makes it more suitable for use in small machines and motorcycles.
7. A two-stroke engine is lighter in weight for the same power and speed especially when the crankcase compression is used.
8. Due to its simpler design, it requires fewer spare parts.
9. A two-stroke cycle engine can be easily reversed if it is of the valve less type.

#### **b) Disadvantages**

1. The scavenging being not very efficient in a two-stroke engine, the dilution of the charges takes place which results in poor thermal efficiency.
2. The two-stroke spark ignition engines do not have a separate lubrication system and normally, lubricating oil is mixed with the fuel. This is not as effective as the lubrication of a four-stroke engine. Therefore, the parts of the two-stroke engine are subjected to greater wear and tear.

3. In a spark ignition two-stroke engine, some of the fuel passes directly to the exhaust. Hence, the fuel consumption per horsepower is comparatively higher.
4. With heavy loads a two-stroke engine gets heated up due to the excessive heat produced. At the same time the running of the engine is riot very smooth at light loads.
5. It consumes more lubricating oil because of the greater amount of heat generated.
6. Since the ports remain open during the upward stroke, the actual compression starts only after both the inlet and exhaust ports have been closed. Hence, the compression ratio of this engine is lower than that of a four-stroke engine of the same dimensions. As the efficiency of an engine is directly proportional to its compression ratio, the efficiency of a two-stroke cycle engine is lower than that of a four-stroke cycle engine of the same size.

## BASIC TERMINOLOGIES OF AN ENGINE

By

*Engr. Dr. Muhammad Azam Khan, Assoc. Professor*

*Engr. Prof. Dr. Muhammad Iqbal, Subject Expert*

1. **Bore** - The diameter of the cylinder is called as bore of an engine (Figure 4.1).
2. **Stroke** - The displacement of the piston from top dead centre (TDC) to bottom dead centre (BDC) is called stroke (Figure 4.1). In old engines, the stroke was always greater than the bore but the recent trend is towards a shorter piston stroke. This is because in the short piston stroke, the loss of power due to friction is minimized. Also, the inertia and centrifugal load on the bearings are reduced. In the square engine, which is the latest in technology, the bore and strokes are equal.

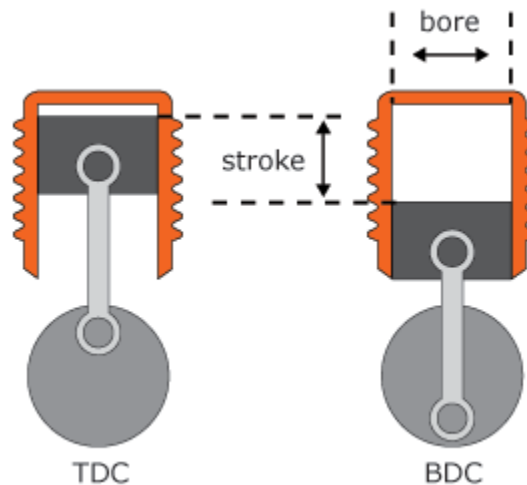

Figure 4.1 Bore and stroke of an engine

3. **Piston Displacement (Swept Volume)** - This is the volume that the piston displaces during its movement from BDC to TDC. Suppose  $D$  is the bore dia. and  $L$  is the stroke length. The piston displacement ( $V$ ) is found as:

$$V = \frac{\pi D^2}{4} \cdot L \text{ ----- 4.1}$$

**Example 1** For a four-cylinder engine with a 10 cm bore dia. and 8 cm stroke length, the piston displacement is;

$$V = \frac{\pi D^2}{4} \cdot L = \frac{\pi 10^2}{4} \cdot 8 = 628.2 \text{ cm}^2$$

**4. Compression Ratio** - The compression ratio (CR) of an engine is a measure of how much the air/air-fuel mixture is compressed in the cylinder. It is the volume of air when the piston is at BDC ( $V_s$ ) divided by its volume of air when the piston is at TDC ( $V_c$ ). The volume above the piston is called clearance volume ( $V_c$ ). Increase in compression ratio increases the engine power.

$$CR = \frac{V_c + V_s}{V_c} \text{----- 4.2}$$

Where,  $V_c$  = clearance volume and  $V_s$  = swept volume

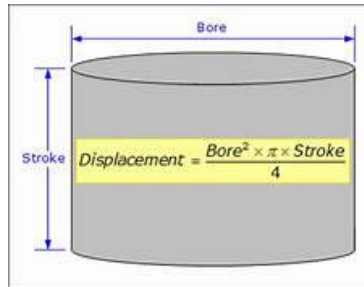

Figure 4.2 Displacement of a piston

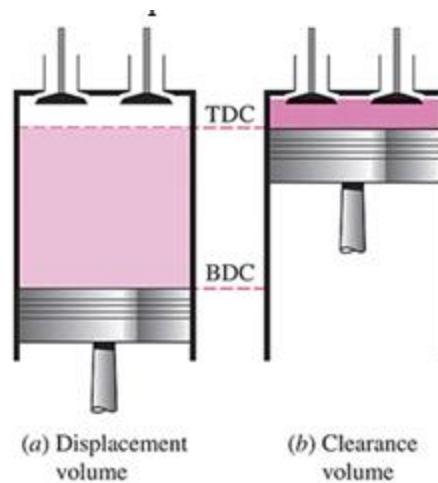

Figure 4.3 Piston displacement and clearance volume

**5. Horse Power** - Power is the rate at which work done. The rate at which the engine can do work is measured in horse power (hp). One hp is equivalent to 550 ft-lb per sec (0.746 W). The various methods of defining horsepower are as following:

**6. Indicated Horse Power** The power that developed in the cylinder by burning of fuel is called indicated horse power and is calculated by:

$$IHP = \frac{P.L.A.N.K}{C} \text{----- 4.3}$$

Where

IHP = Indicated horsepower, kW [hp]; P = effective pressure,  $\text{kN.m}^{-2}$  [PSF]; L = stroke length, m [ft]; A = area of cylinder,  $\text{m}^2$  [ $\text{ft}^2$ ]; N = engine RPM; K = number of cylinders; C = constant 60 [33000]

**7. Brake Horse Power** - It is the horsepower available on the crankshaft and is measured by a dynamometer.

**8. Belt Horse Power** - It is the power of the engine measured at the end of a suitable belt, receiving drive from the power take off (PTO) shaft of the tractor.

**9. PTO Power** - It is the power delivered by a tractor through its PTO shaft.

$$PTOP = \frac{2\pi FRN}{C} = \frac{2\pi TN}{C} \text{-----} 4.4$$

Where,

PTOP = PTO power, kW [hp]; F = tangential force, kN [Ib]; R = force rotation radius, m [ft]; N = RPM, T = torque, kN-m [ft-Ib]; C = constant, 60 [33,000]

**10. Drawbar power [DBP]** - It is the power of a tractor measured at the end of the drawbar. It is that power which is available to pull loads.

$$P_{db} = \frac{F \cdot S}{C} \text{-----} 4.5$$

Where;  $P_{db}$  = drawbar power, kW [hp]; F = horizontal draft, kN [Ib]; S = tractor forward speed, km/h [MPH]; C = 3.6 [375]

**11. Hydraulic Power (HyP)**

$$H_yP = \frac{pQ}{C} \text{-----} 4.6$$

Where,

HyP = hydraulic power, kW [hp]; p = gage pressure, kPa [psi]; Q = fluid flow rate, L/s [gal/min]; C = constant, 1000 [1714].

**12. Electric Power (EP)**

$$EP = IE \text{-----} 4.7$$

Where,

EP = electric power, W; I = electric flow rate, A; E = electric potential, V (DC)

Mechanical power transmission efficiencies for a tractor on concrete surface have been presented in Figure 4.4.

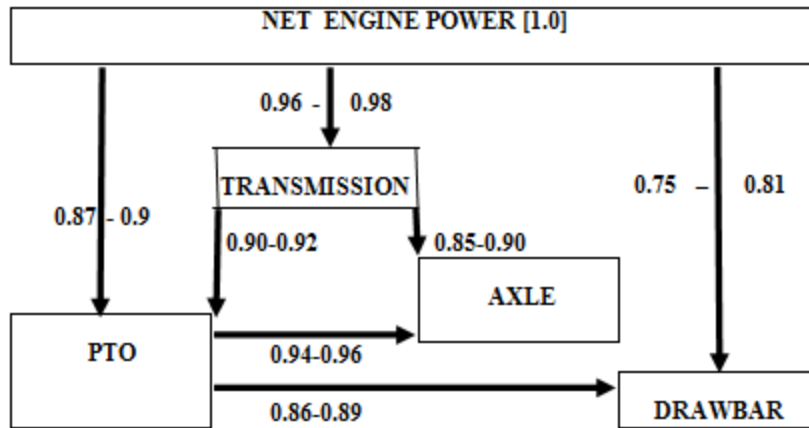

Figure 4.4 Power efficiencies for tractor on concrete

(Source: Farm Power and Machinery Management by Donnell Hunt, Iowa State University Press, 1995)

## CHAPTER-5

# INTERNAL COMBUSTION ENGINE SYSTEM

By

*Engr. Dr. Muhammad Azam Khan, Assoc. Professor*

*Engr. Prof. Dr. Muhammad Iqbal, Subject Expert*

### 1. Intake and Exhaust System

The intake and exhaust system deals with the inflow of fresh air and the outflow of used gases in the engine.

### 2. Air Intake System

This system allows fresh air to enter the engine. Its main parts are:

Air cleaner, Supercharger (auxiliary unit), Intake manifold, Intake port and Intake valve.

### 3. Air Cleaner

It is a device, which cleans and filters the air before entering the combustion chamber of an engine. An IC engine uses large quantities of air for combustion, the ratio being 14-15 lb of air for every lb of fuel bursts. The volume of the air used is about 10,000 gal/gal of fuel. Unfiltered air may contain millions of particles of abrasive dust and other matter, which could cause rapid wear. There are two types of air cleaners but the types commonly used in tractors are:

- Dry air type
- Wet type or oil bath air cleaners.

**Dry Air Cleaner** - This type of air cleaners contains three main parts, viz. pre-cleaner, main housing and cleaning element (Figure 5.1). These are sealed into one unit. The main housing contains the cleaning element, usually of multi-wire netting, but some are made of nylon hair or paper. The air from the atmosphere enters from the pre-cleaner, passes through the cleaning element and goes to the inlet manifold. The paper filter element is cleaned after 50-100 hours of service. Dry air cleaners are mounted (i) vertically in front of the tractor radiator and (ii) horizontally on the overhead engine.

#### **Advantages of dry air cleaner**

- Easy to service.
- Good performance in gradient and in rough fields.
- More efficient at high speeds.

- Straw and chaff cause less restriction to air passage.

**Disadvantages of dry air cleaner:**

- Costly to maintain than an oil bath because the filter elements require replacements very often.
- Sometimes, dust particles enter the cylinder

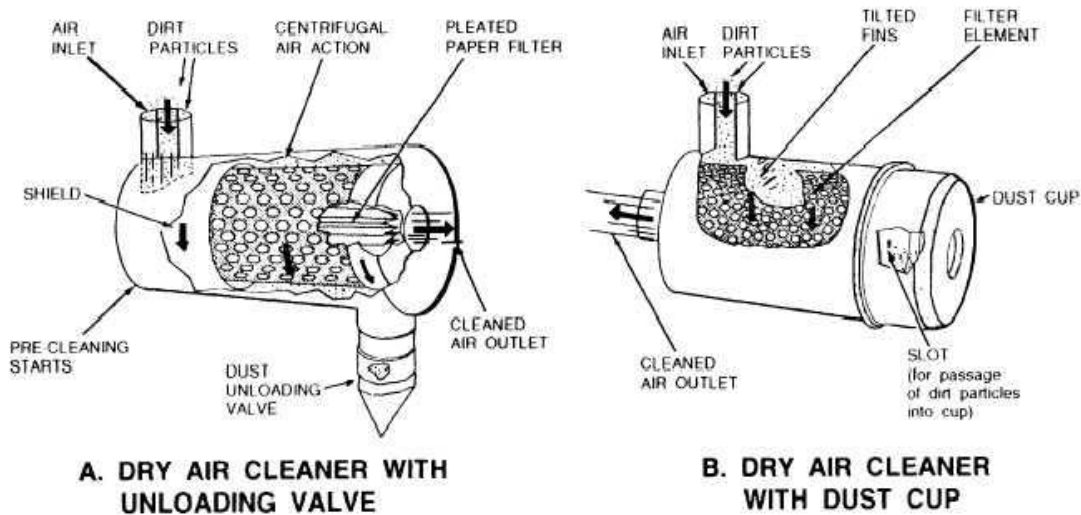
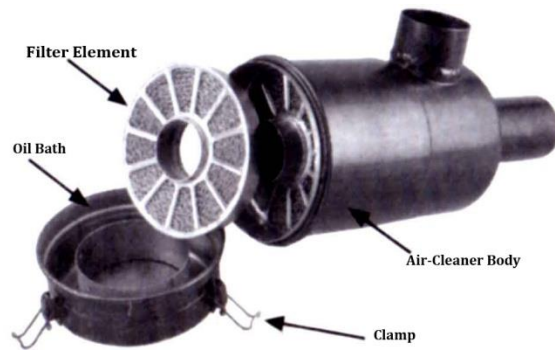
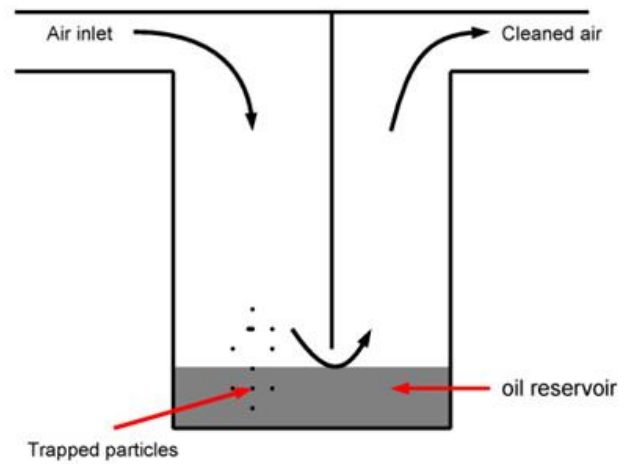

Figure 5.1 Dry air cleaner

**Oil Bath Air Cleaners** - In this oil is used for cleaning air (Figure 5.2). This type of cleaner operates on the principle of having the air with dust enter the intake stack, pass down the inlet passage over the oil surface, where some of the oil is picked up, atomized and carried up into a separating screen. As the air passes through a filter element most of the remaining dirt is attached to the oil wetted surfaces and drains back into the sump. The air outlet is on the side through which the clean air enters the cylinders. In the bottom a removable cup is fitted for convenient cleaning and servicing. Oil bath air cleaners are always mounted vertically to the engine, thus the oil remains in the cup at the bottom of the cleaner. It is often mounted either in front of the radiator or by the side of the engine.



Oil bath air cleaner



Oil bath cleaner

Figure 5.2 Oil bath air cleaner

#### 4. Pre-cleaner of Tractor engine

Tractors always work in dusty conditions. In order to prolong the engine life, pre-cleaners are fitted in the upper portion of the main cleaner (Figure 5.3). When the engine is running, the air is drawn through the pre-cleaner to the inlet tube of the main cleaner. Here large dust particles are removed from the air stream, thus reducing much of the load on the main cleaner. The pre-cleaner functions on the centrifugal principle. By means of vanes and baffles it gives a rotary motion to the air, thus causing the heavier dust particles to be thrown out due to centrifugal force and the pre-cleaned air passing to the cleaner.



Figure 5.3 Pre cleaner

## 5. Superchargers

A supercharger is a device for increasing the air pressure into the engine so that more fuel can be burnt and the engine output increased. The pressure inside the manifold of a supercharger engine will be greater than the atmosphere pressure. Supercharged air is provided either by positive displacement rotary blowers or by centrifugal blowers. These may be belt driven by the engine itself or from a separate power source such as an electric motor or from an exhaust gas turbine.



Figure 5.4 Supercharger

## 6. Inlet Manifold

The inlet manifold is required to deliver into the cylinders either a mixture of fuel and air from the carburetor or only air from air-cleaners (Figure 5.5). The inlet manifolds are made in one or two pieces either from cast iron or aluminum alloy. They are also bolted from separate castings into a single unit. The manifold flanges are connected to the cylinder block or cylinder head by means of asbestos-copper gaskets, studs and nuts. Tractor intake system has been presented in Figure 5.6.



Figure 5.5 Inlet manifold

# Intake System

## Parts:

1. Pre-Cleaner
2. Air Cleaner
3. Intake Manifold
4. Intake Valve
5. Turbocharger (if used)
6. Intercooler (if used)

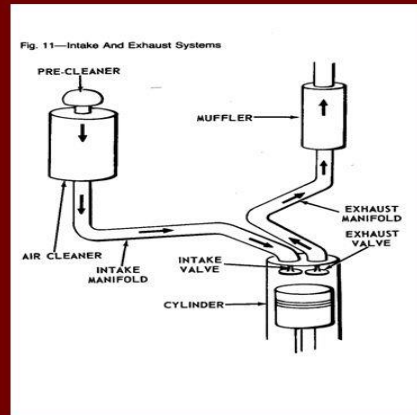

Figure 5.6 Tractor intake systems

## 7. Exhaust System

The exhaust system collects exhaust gases from the engine and expels them out (Figure 5.7).

The exhaust system consists of: 1) exhaust valve, 2) exhaust port, 3) exhaust manifold, 4) turbo charger (auxiliary unit) and 5) muffler.



Exhaust manifold



Exhaust port



Muffler

Figure 5.7 Tractor exhaust system

## 8. Exhaust Manifold

The exhaust manifold collects exhaust gases from the exhaust ports of various cylinders and conducts them from each end to a central exhaust passage. It is usually made of cast iron. The exhaust manifolds are designed to avoid the overlapping of exhaust strokes as much as possible,

thus keeping the back pressure to a minimum. This is often done by dividing the exhaust manifold into two or more branches so that no two cylinder will exhaust into the same branch at the same time.

## 9. Turbocharger

This is an exhaust driven turbine, which drives a centrifugal compressor wheel. The compressor passage is usually located between the air cleaner and engine intake manifold, while the turbine is located between the exhaust manifold and muffler.

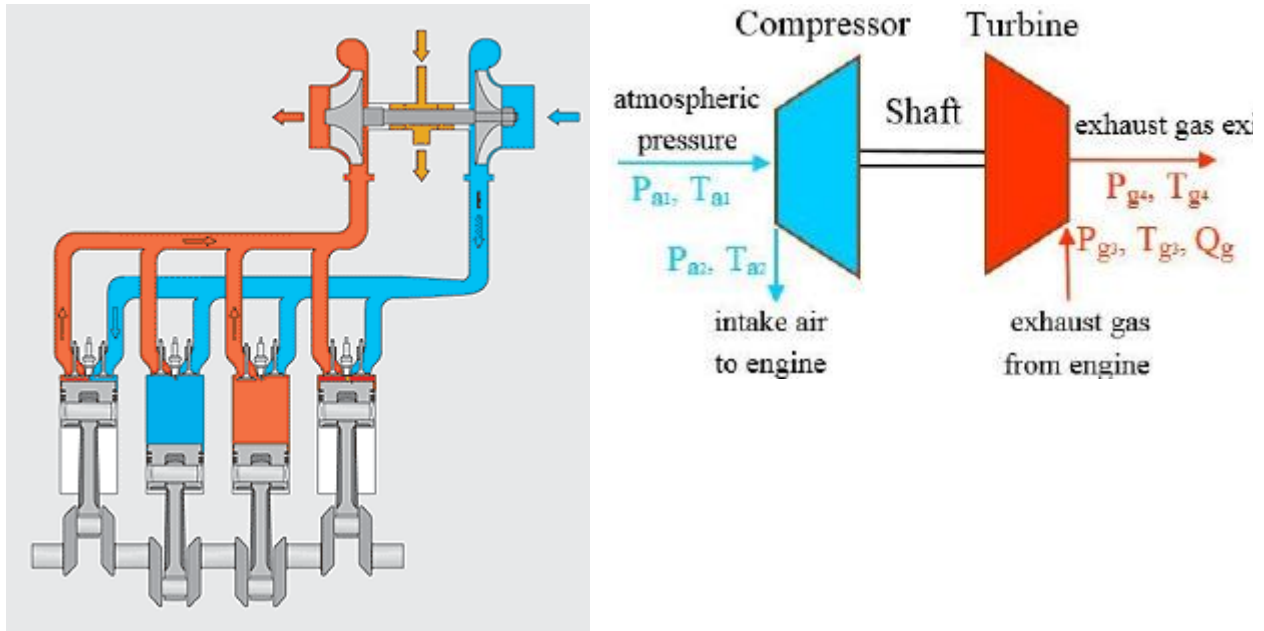

Figure 5.8 Turbocharger

## 10. Muffler

The muffler reduces the noise of the exhaust gases by reducing the pressure of the used gases by slow expansion and cooling. On the other hand, the muffler must not cause any appreciable restriction to the flow of gas that could raise the backpressure excessively. The muffler contains a number of chambers through which the gas flows. The gas is allowed to expand from the first passage into a much larger second one and then to a still larger third one and so on, to the final and largest passage which is connected to the tail (outlet) pipe of muffler.

## 11. Engine Valve Timing

**Arrangement of valves** - The valve arrangements are generally classified as L-head, I-head, T-head and F-head according to the arrangements of the valves. In the L-head design, both the inlet and exhaust valves are on one side of the engine. Sometimes it is called the side valve

engine and is operated by a single camshaft, whereas the T-head engine requires two camshafts, with valves arranged in block. The I-head engine is also known as overhead valve engine

**Valve Operation** - The valves of an internal combustion engine are meant to admit air or air-fuel mixture into the cylinder and finally to let the exhaust gases go out (Figure 5.9). Most engines are provided with one inlet and one exhaust valve for each cylinder. These valves are usually of equal size, though sometimes the inlet valves are made larger in size than exhaust valves. The valve stem is surrounded by a removable guide and spring holds the valve against seat. The rocker arm assembly is operated by a camshaft through a push rod, forces the valves open at the desired time. To take care of mechanical wear, the valve face is generally made of heat resisting alloys. Clearance between the rocker arm and valve stem is provided to enable the valves to seat properly. This clearance is also known as tappet clearance, and should be adjusted with feeler gauge according to the manufacture's specifications. The valve tappet clearance is adjusted when both the valves are in the shut position. A typical value of valve tappet clearance is given as 0.38 mm (0.015 in).

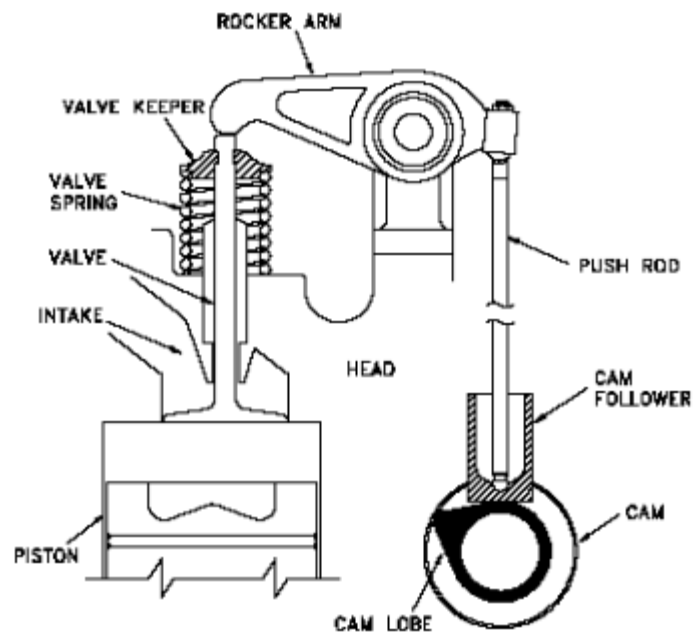
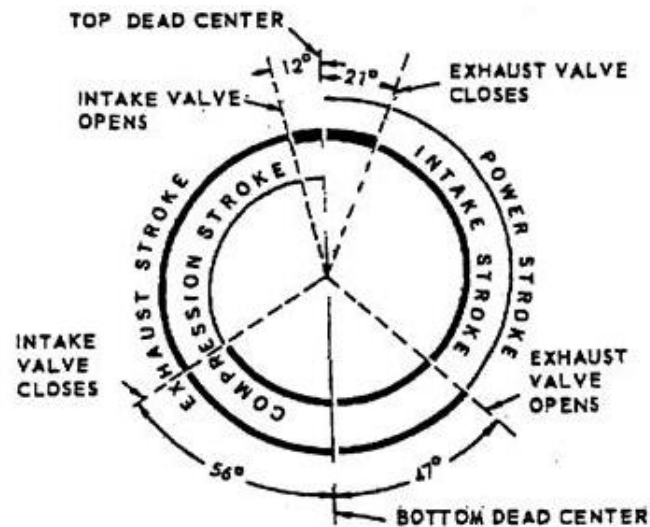
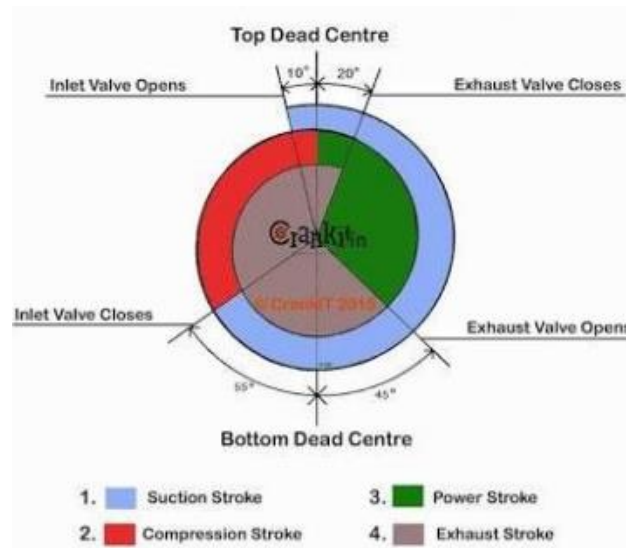

Figure 5.9 Diesel engine valve train

### Valve Timing Diagram

- Inlet valve begins to open  $10^{\circ}$  before the piston has reached the TDC. It remains open till the piston has passed 55 degrees over the BDC (Figure 5.10).

- Both inlet and exhaust valves remain closed during the compression stroke and most of the time in the power stroke. In terms of crank angle, both, the valves remain closed for about 285 degrees.
- On the power stroke the exhaust valve begins to open between 30 and 45 degrees before the BDC and it continues to open till the piston has passed over about 20° the TDC. Thus the exhaust valve remains open about 225 degrees or about



**Fig** Intake- and exhaust-valve timing. The complete cycle of events is shown as a 720° spiral, which represents two complete crankshaft revolutions. Timing of valves differs for different engines.

Figure 5.10 Valve timing diagram

## 12. Firing order

The sequence in which the combustion of fuel in the cylinder takes place in a multi cylinder engines is called the firing order of engines.

Crankshaft degrees	4 - Cylinders FO: 1-3-4-2			
	1	2	3	4
0	1	2	3	4
180	Power stroke	Exhaust	Compression	Suction
360	Exhaust	Suction	Power stroke	Compression
540	Suction	Compression	Exhaust	Power stroke
720	Compression	Power stroke	Suction	Exhaust

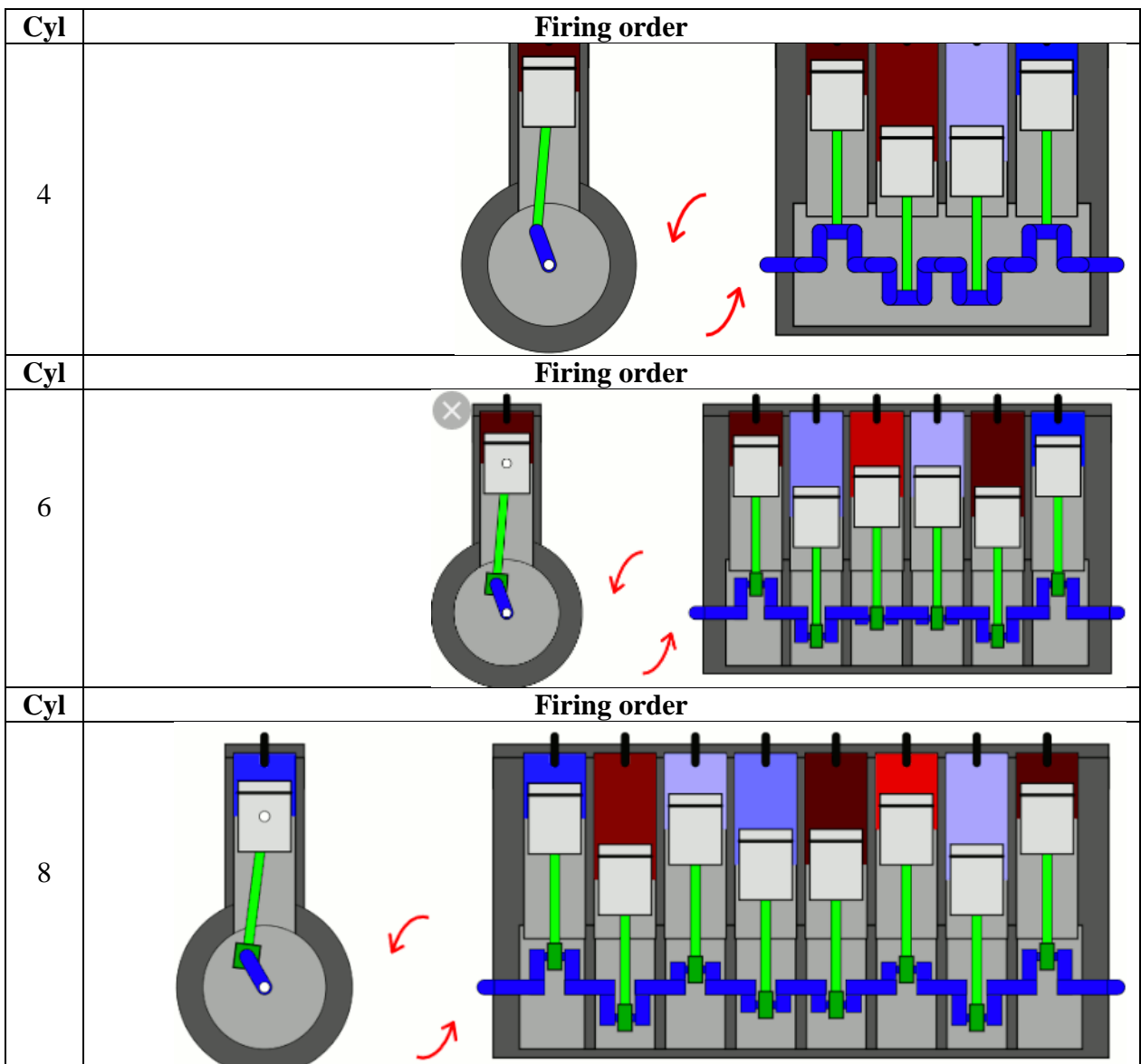

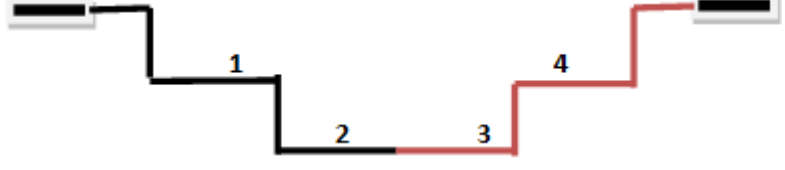
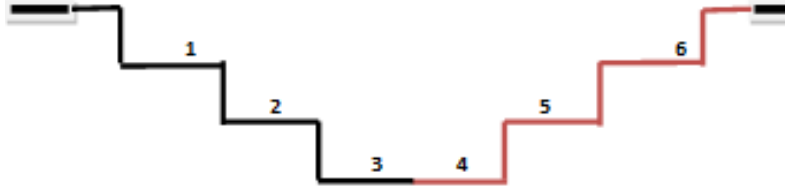
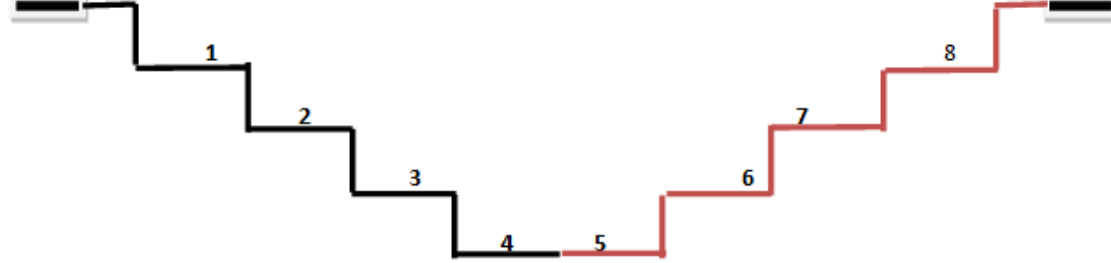
4	 <p style="text-align: right;"><b>FO: 1-3-4-2</b></p>
6	 <p style="text-align: right;"><b>FO: 1-5-3-6-2-4</b></p>
8	 <p style="text-align: right;"><b>FO: 1-7-3-5-8-2-6-4</b></p>

## FUEL & FUEL SYSTEM

By

*Engr. Prof. Dr. Muhammad Iqbal, Subject Expert  
Engr. Dr. Muhammad Azam Khan, Assoc. Professor*

### 6.1 Properties of Fuel

Fuel is a substance consumed by the engine to produce energy. The common fuels for internal combustion engines are:

- Petrol
- Diesel oil

### 6.2 Quality of Fuel

The quality of the fuel mainly depends upon the following properties:

- Volatility of the fuel
- Calorific value of the fuel
- Ignition quality of the fuel

**6.2.1 Volatility:** Volatility of fuel has considerable effect on the performance of the engine by affecting the following:

- Ease of starting the engine.
- Degree of crankcase oil dilution,
- Formation of vapor lock in the fuel system,
- Accelerating characteristics of the engine,
- Distribution of fuel in multi-cylinder engine.

In I.C. engine, all the liquid fuel must be converted into vapor fuel before burning. High speed diesel oil is most difficult to vaporize. Vaporizing temperature of high speed diesel oil is higher than that of the petrol. Hence the petrol vaporizes quicker than diesel oil in the engine cylinder. This helps in easy starting of petrol engines.

**6.2.2 Calorific value:** The heat liberated by combustion of a fuel is known as calorific value or heat value of the fuel. It is expressed in kcal/kg of the fuel. The heat value of a fuel is an important measure of its worth, since this is the heat which enables the engine to do the work.

**6.2.3 Ignition quality:** Ignition quality refers to ease of burning the oil in the combustion chamber. Octane number and cetane number are the measures of ignition quality of the fuel.

- **Octane number:** It is a measure of knock characteristics of a fuel. The percentage of iso-octane ( $C_8H_{18}$ ) in the reference fuel consisting of a mixture of iso-octane and normal heptane ( $C_7H_{16}$ ), when it produces the same knocking effect as the fuel under test, is called octane number of the fuel. Iso-octane has excellent antiknock qualities and is given a rating of 100. Normal heptane would knock excessively and hence it is assigned a value of zero.
- **Cetane number:** The percentage of cetane in a mixture of cetane ( $C_{16}H_{34}$ ) and alphas-methyl naphthalene ( $C_{11}H_{16}$ ) that produces the same knocking effect as the fuel under test is called cetane number of the fuel. Diesel fuels are rated according to cetane number which is the indication of ignition quality of the fuel. The higher the cetane number the better the ignition quality of the diesel fuel. The commercial diesel fuels have got cetane rating varying from 30 to 60.
- **Detonation (Knocking):** Detonation or engine knocking refers to violent noises, heard in an engine, giving a pinging sound during the process of combustion. It occurs during the process of combustion of the mixture within the cylinder after the ignition has taken place. It is an undesirable combustion and results in sudden rise in pressure, a loss of power and overheating of the engine. It is caused by improper combustion chamber, high compression pressure, early ignition timing, improper fuel and inadequate cooling arrangement.
- **Pre-ignition:** Burning of air-fuel mixture in the combustion chamber before the piston has reached the top dead centre is called pre-ignition. Pre-ignition occurs when the charge is fired too far ahead of the top dead centre of the piston due to excessive spark advance or excessive heat in the cylinder.

### 6.3 Fuel Supply System in Spark Ignition Engine

The fuel supply system of spark ignition engine consists of (Figure 6.1):

Fuel tank, Fuel filter, Sediment bowl, Fuel lift pump, Carburetor, Fuel pipes and Inlet manifold

In some spark ignition engine, the fuel tank is placed above the level of the carburetor. The fuel flows from the fuel tank to the carburetor under the action of gravity. There are one or two filters between the fuel tank and the carburetor. A transparent sediment bowl is also provided to

hold the dust and dirt of the fuel. If the tank is below the level of the carburetor, a lift pump is provided in between the tank and the carburetor for forcing fuel from the tank to the carburetor of the engine. The fuel comes from the fuel tank to the sediment bowl and then to the lift pump. From there the fuel goes to the carburetor through suitable pipe. From the carburetor, the fuel goes to the engine cylinder, through the inlet manifold of the engine.

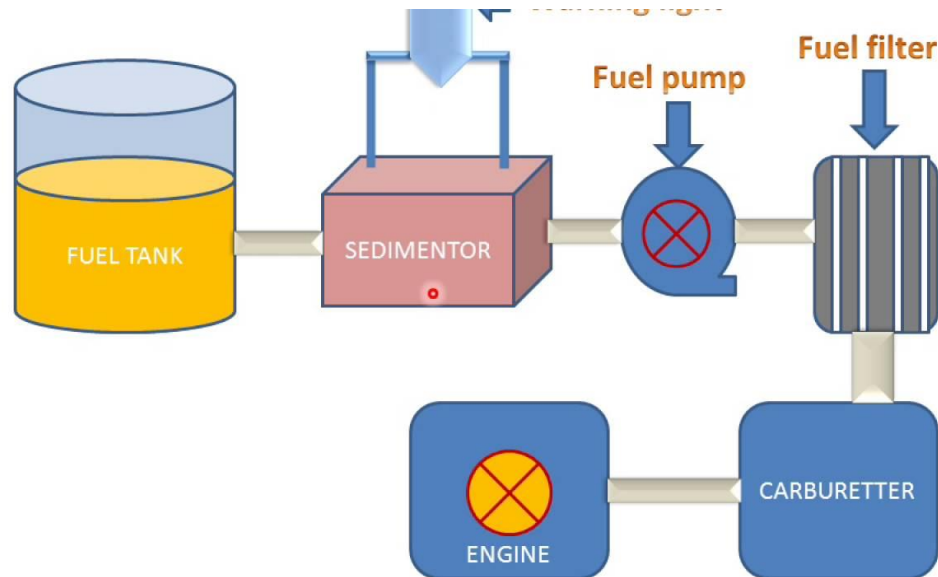

**Figure 6.1 Fuel Supply System in Spark Ignition Engine**

### 6.3.1 Carburetor

The process of preparing an air-fuel mixture away from the cylinders of an engine is called carburetion and the device in which this process take place is called carburetor (Figure 6.2).

**Principle of carburetor:** The basic principle of all carburetor design that when air flows over the end of a narrow tube or jet containing liquid, some liquid is drawn into the air stream. The quantity of liquid drawn into the air stream increases as the speed of air flow over the jet increases and also the quantity is greater if the jet is made larger. The fuel level in the jet is maintained by a float chamber. The fuel levels in the jet and in the float chamber are always the same. As the fuel is consumed, the level in the float chamber goes down. The float in the float chamber also goes down and the needle valve comes off its seat allowing more fuel into the chamber from the fuel tank. When the fuel level rises to its correct level, the float presses the needle valve back to its seat and cuts off the fuel flow. The velocity of the air flowing over the jet is increased by a constriction in the induction pipe known as venturi. A throttle butterfly valve provides an adjustable obstruction in the induction pipe. It is used to control the flow of

air-fuel mixture to the engine. As the throttle valve is turned into the accelerate position, the airflow over the jet increases and more fuel is drawn out into the air stream, keeping the mixture strength constant. A choke valve is used to provide a richer mixture for the engine to start in cold condition. The choke controls the volume of air entering into the venturi. A second jet is fitted near the throttle butterfly, which is used when the engine is idling. Fuel is delivered to the float chamber through fuel pipe either by gravity or by a pump. The float chamber is connected with the mixing chamber (venturi) via fuel nozzle equipped with fuel jet.

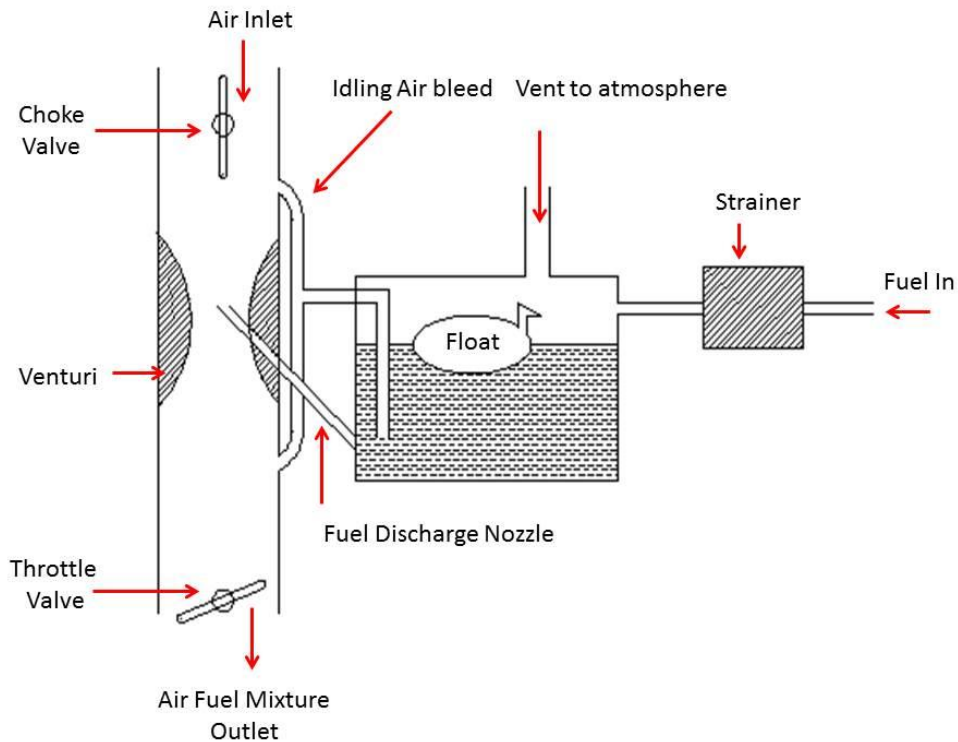

**Figure 6.2 Carburetor**

**Function of Carburetor:** The main functions of the carburetor are:

- To mix the air and fuel thoroughly
- To atomize the fuel
- To regulate the air-fuel ratio at different speeds and loads and
- To supply correct amount of mixture at different speeds and loads.

#### **6.4 Fuel System of Diesel Engine**

During engine operation, the fuel is supplied by gravity from fuel tank to the primary filter where coarse impurities are removed. From the primary filter, the fuel is drawn by fuel transfer pump and is delivered to fuel injection pump through second fuel filter (Figure 6.3). The fuel

injection pump supplies fuel under high pressure to the injectors through high pressure pipes. The injectors atomize the fuel and inject it into the combustion chamber of the engine. The fuel injection pump is fed with fuel in abundance. The excess fuel is by-passed to the intake side of the fuel transfer pump through a relief valve. The main components of the fuel system in diesel engine are: (1) fuel filter (2) fuel lift pump (3) fuel injection pump (4) atomizers and (5) high pressure pipe.

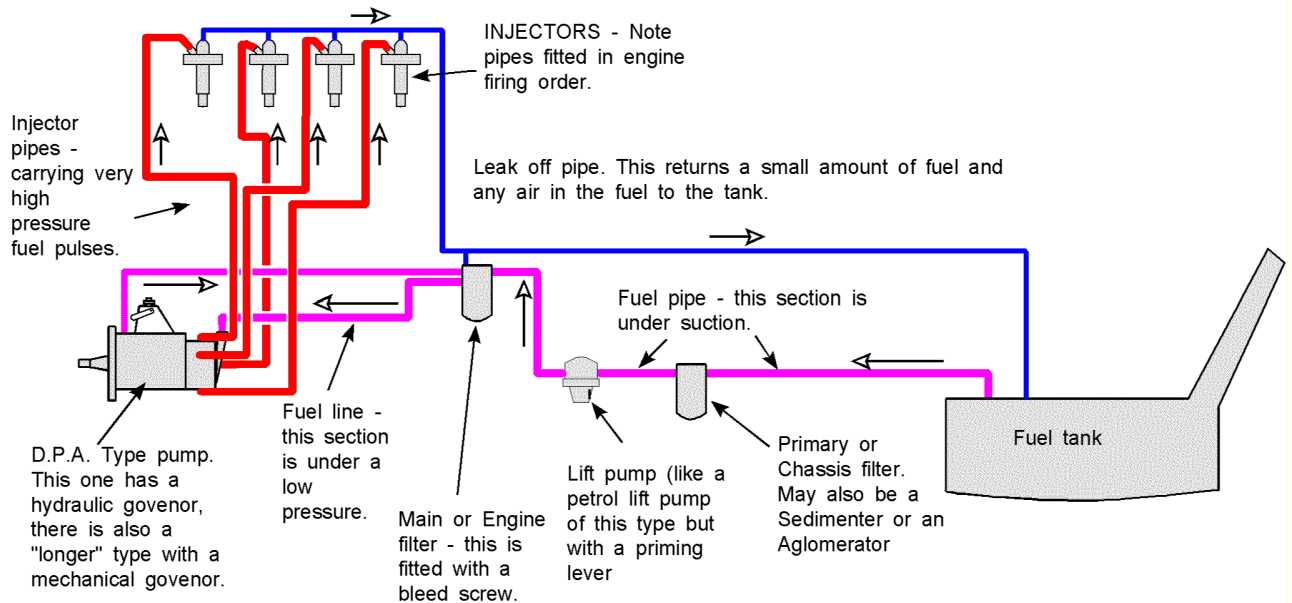

**Figure 6.3 Fuel System of Diesel Engine**

Following two conditions are essential for efficient operation of fuel system:

- The fuel oil should be clean, free from water, suspended dirt, sand or other foreign matter,
- The fuel injection pump should create proper pressure, so that diesel fuel may be perfectly atomized by injectors and be injected in proper time and in proper quantity in the engine cylinder. Fuel should be filtered before filling the tank also. If these precautions are followed, ninety per cent of diesel engine troubles are eliminated.

### **Fuel Lift Pump (Feed Pump or Transfer Pump)**

It is a pump, which transfers fuel from the fuel line to the fuel injection pump (Figure 6.4). It is mounted on the body of fuel injection pump. It delivers adequate amount of fuel to the injection pump. The pump consists of: 1) Body, 2) Piston, 3) inlet valve and 4) pressure valve.

The valves are tightly pressed against their seats by springs. The piston is free to slide in the bore. The fuel contained in the space below the piston is forced to flow through secondary fuel filter to the injection pump. At the same time downward movement of the piston creates a depression in the space above the piston which, causes the fuel to be drawn in the transfer pump from the fuel tank through the inlet valve and the primary filter.

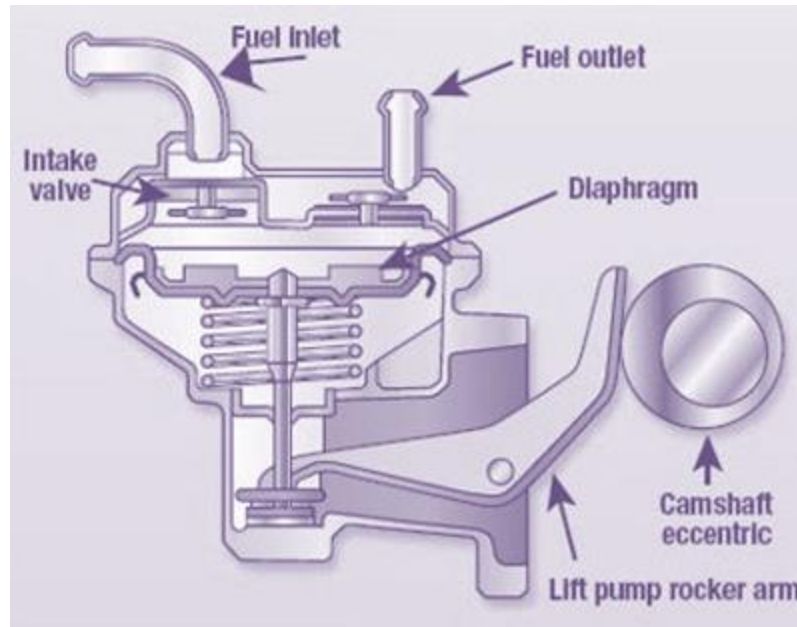

**Figure 6.4 Fuel Lift Pump**

### **Fuel Injecting Pump**

It is a pump, which delivers metered quantity of fuel to each cylinder at appropriate time under high pressure. Tractor engines may use two types of fuel injection pump:

(i) Multi-element pump and (ii) Distributor (Rotary) type pump (Figure 6.5).

**Fuel Injector:** It is the component, which delivers finely atomized fuel under high pressure to the combustion chamber of the engine. Modern tractor engines use fuel injectors, which have multiple holes. Main parts of injector are: nozzle body and needle valve. The nozzle body and needle valve are fabricated from alloy steel. The needle valve is pressed against a conical seat in the nozzle body by a spring. The injection pressure is adjusted by adjusting the screw.

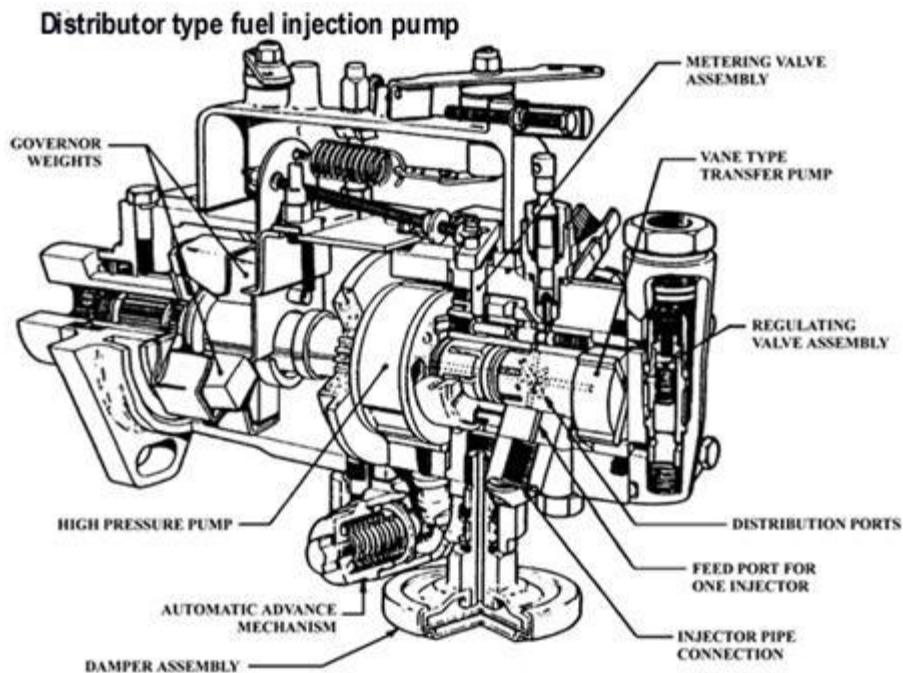
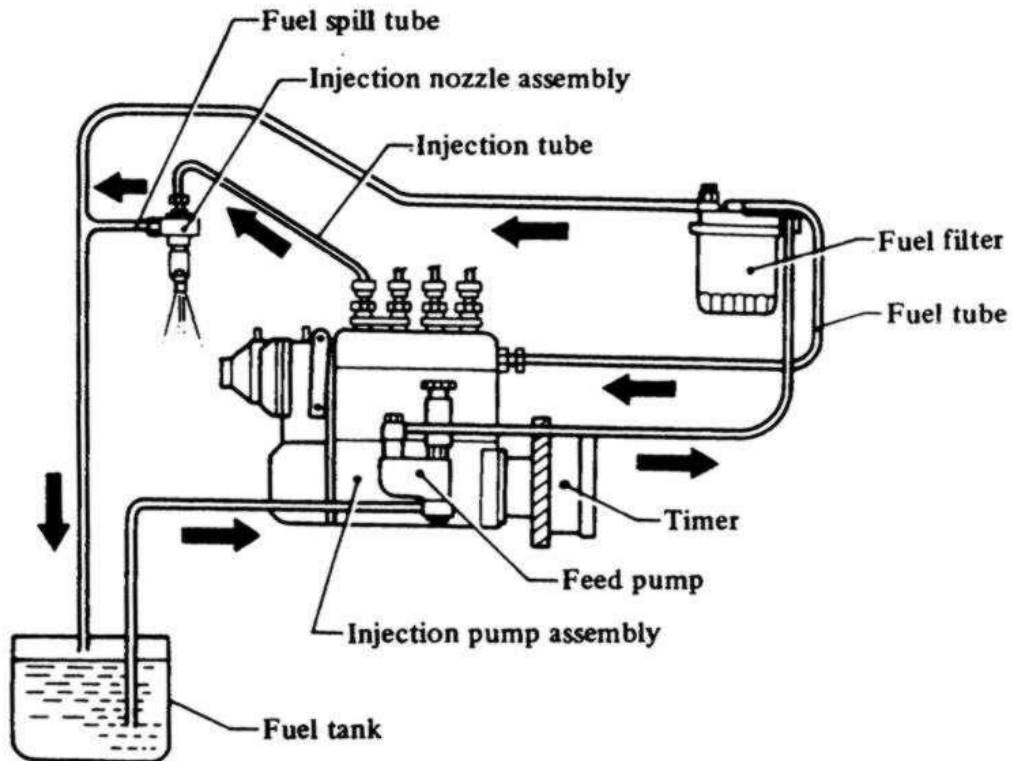

**Figure 6.5 Distributor (Rotary) type pump**

### **Fuel Injection System**

Diesel fuel is injected in diesel engine through injectors with the help of fuel injection pump. The system using injectors, fuel injection pump, fuel filter, and fuel lines is called fuel injection system (Figure 6.6). The main functions of fuel injection system are:

- To measure the correct amount of fuel required by engine speed and load,
- To maintain correct timing for beginning and end of injection,
- To inject the fuel into the combustion space against high compression pressure.
- To atomize the fuel for quick ignition.



**Figure 6.6 Fuel Injection System**

### **Fuel Filter**

It is a device to remove dirt from fuel oil. Solid particles and dust in diesel fuel are very harmful for giving a fine degree of filtration. Fuel injection equipment in diesel engines is extremely sensitive to dirt and solid particles present in fuel. A filter is used to remove the dirt and solid particles from the fuel to ensure trouble free fuel supply. It consists of a hollow cylindrical element contained in a shell, an annular space being left between the shell and the element. The filtering element consists of metal gauze in conjunction with various media such as packed fibres, woven cloth, felt, paper etc. These filters are replaced at certain intervals, specified by the manufacturer. Usually there are two filters in diesel engine (Figure 6.7):

- Primary filter
- Secondary filter.

The primary filter removes water and coarse particle of dirt from the fuel. The secondary filter removes fine sediments from the fuel.

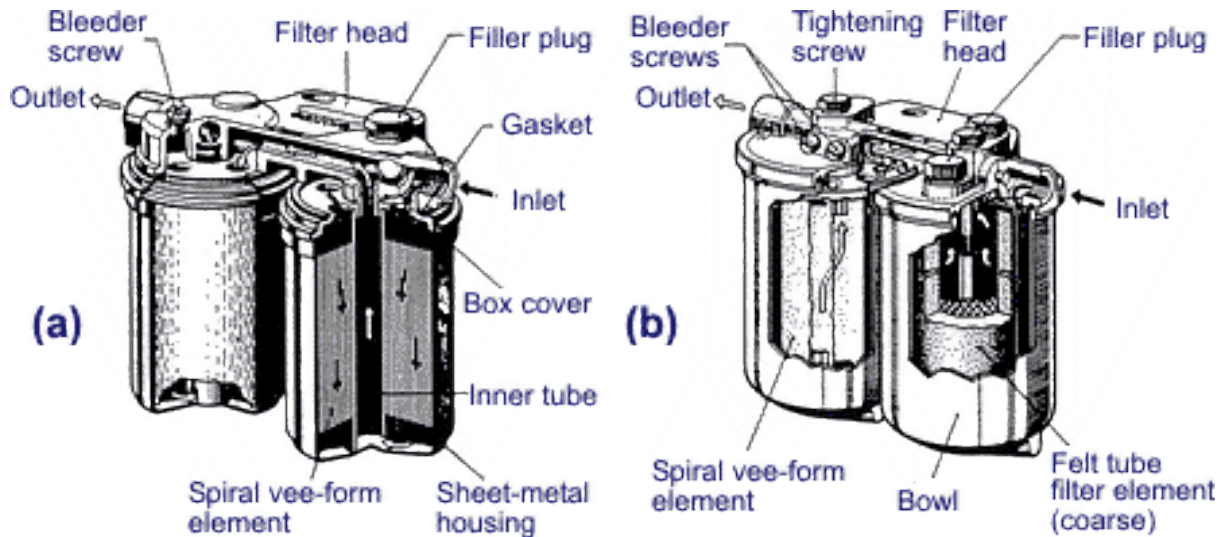

**Figure 6.7 Fuel filters**

### Ignition System

There are four different systems of igniting fuel:

- Ignition by electric spark i.e. spark ignition
- Ignition by heat of compression i.e. compression ignition

### Spark Ignition

The purpose of spark ignition is to deliver a perfectly timed surge of electricity across an open spark plug gap in each cylinder at the exact moment so that the charge may start burning with maximum efficiency. There are two methods in spark ignition: (a) Battery ignition and (b) Magneto ignition (Figure 6.8).

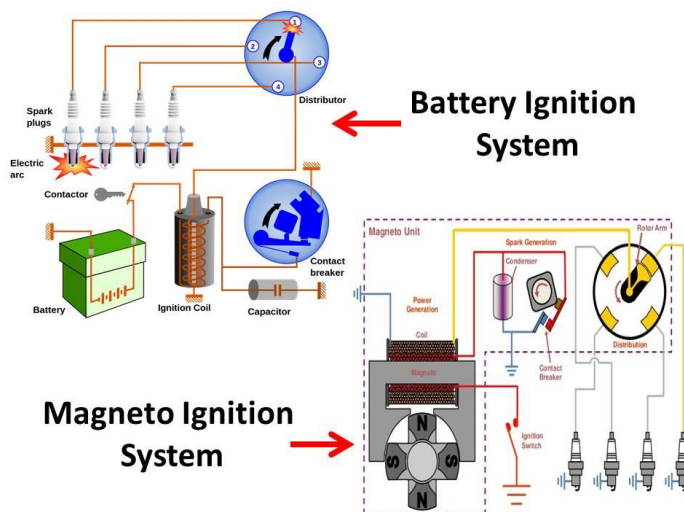

**Figure 6.8 Magneto Ignition System**

## Storage Battery

Storage battery is a device for converting chemical energy into electrical energy (Figure 6.9). There are several types of battery, but lead-acid battery is most common for I. C. engines, used for tractors and automobiles. A battery consists of: (i) Plates (ii) Separators (iii) Electrolyte (iv) Container and (v) Terminal wire.

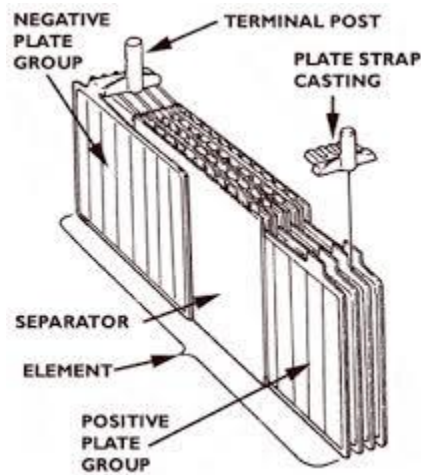

**Figure 6.9 Storage Battery**

## Governor

Governor is a mechanical device designed to control the speed of an engine within specified limit used on tractor or stationary engines for:

- Maintaining a nearly constant speed of engine under different load conditions
- Protecting the engine and the attached equipments against high speeds, when the load is reduced or removed.

Tractor engines are always fitted with governor (Figure 6.10). There is an important difference in principle between the controls of a tractor engine and that of a motor car. In case of motor car, the fuel supply is under direct control of the accelerator pedal, but in tractor engine, the fuel supply is controlled by the governor. The operator changes the engine speed by moving the governor control lever. A governor is essential on a tractor engine for the reason that load on the tractor engine is subjected to rapid variation in the field and the operator cannot control the rapid change of the engine speed without any automatic device. For example, if the load on the tractor is reduced, the engine would tend to race suddenly. If the load is increased, the engine would tend to slow down abruptly. Under these circumstances, it becomes difficult for the operator to regulate always the throttle lever to meet the temporary changes in the engine load.

A governor automatically regulates the engine speed on varying load condition and thus the operator is relieved of the duty of constant regulating the throttle lever to suit different load conditions.



**Figure 6.10 Governor**

### **Types of governors**

1. Centrifugal governor
2. Pneumatic governor
3. Hydraulic governor

**Governor regulation** - The governor is fitted on an engine for maintaining a constant speed, even then some variation in speed is observed at full load and no load conditions. In normal working, a variation of about 100 rev/min is observed between full load and no-load conditions for a good governor. Hence it is possible to regulate the governor to maintain a higher or lower speed by changing the tension of the spring . The extent of regulation done, is expressed in terms of percentage called percentage regulation. This is also called speed drop. It is the variation in the engine speed between full load and no load condition. It is usually expressed as percentage of rated speed. This is given by:

$$R = \frac{N_1 - N_2}{(N_1 + N_2)/2} \times 100 \text{ ----- 6.1}$$

Where ,

R – % regulation,

N1 – Speed at no load, rpm

N2 – Speed at full load, rpm

Problem- Find the percentage regulation in a governor if speed at no load is 1600 rev/min and at full load is 1500 rev/min

### **Governor hunting**

Governor hunting is the erratic variation of the speed of the governor when it over compensates for speed changes. When the governor produces a periodic effect on the engine speed like too fast and then too slow, then too fast and so on it is a sign of governor hunting. In such cases it is observed that when the engine speeds up quickly, the governor suddenly responds, the speed drops quickly, the governor again responds and this process is repeated. The reason for governor hunting may be due to incorrect adjustment of fuel pump or carburetor, improper adjustment of the idling screw and excessive friction. Hunting may be due to governor being too stiff or due to some obstruction in free movement of governor components.

## CHAPTER-7

# ENGINE COOLING AND LUBRICATION SYSTEMS

By

*Engr. Prof. Dr. Muhammad Iqbal, Subject Expert*  
*Engr. Dr. Muhammad Azam Khan, Assoc. Professor*

A system, which controls the engine temperature, is known as a cooling system.

### 7.1 Necessity of Cooling System

The cooling system is provided in the IC engine for the following reasons:

The temperature of the burning gases in the engine cylinder reaches up to 1500 to 2000°C, which is above the melting point of the material of the cylinder body and head of the engine. (Platinum, a metal which has one of the highest melting points, melts at 1750 °C, iron at 1530°C and aluminum at 657°C.) Therefore, if the heat is not dissipated, it would result in the failure of the cylinder material.

- Due to very high temperatures, the film of the lubricating oil will get oxidized, thus producing carbon deposits on the surface. This will result in piston seizure.
- Due to overheating, large temperature differences may lead to a distortion of the engine components due to the thermal stresses set up. This makes it necessary for, the temperature variation to be kept to a minimum.

Higher temperatures also lower the volumetric efficiency of the engine.

### 7.2 Requirements of Efficient Cooling System

The two main requirements of an efficient cooling system are:

- It must be capable of removing only about 30% of the heat generated in the combustion chamber. Too much removal of heat lowers the thermal efficiency of the engine.
- It should remove heat at a fast rate when the engine is hot. During the starting of the engine, the cooling should be very slow so that the different working parts reach their operating temperatures in a short time.

### 7.3 Types of Cooling System

There are two types of cooling systems:

- Air cooling system and
- Water-cooling system.

### 7.3.1 Air Cooling System

In this type of cooling system, the heat, which is conducted to the outer parts of the engine, is radiated and conducted away by the stream of air, which is obtained from the atmosphere (Figure 7.1). In order to have efficient cooling by means of air, providing fins around the cylinder and cylinder head increases the contact area.

The fins are metallic ridges, which are formed during the casting of the cylinder and cylinder head. The amount of heat carried off by the air-cooling depends upon the following factors:

- The total area of the fin surfaces,
- The velocity and amount of the cooling air and
- The temperature of the fins and of the cooling air.

Air-cooling is mostly tractors of less horsepower, motorcycles, scooters, small cars and small aircraft engines where the forward motion of the machine gives good velocity to cool the engine. Air-cooling is also provided in some small industrial engines. In this system, individual cylinders are generally employed to provide ample cooling area by providing fins. A blower is used to provide air.

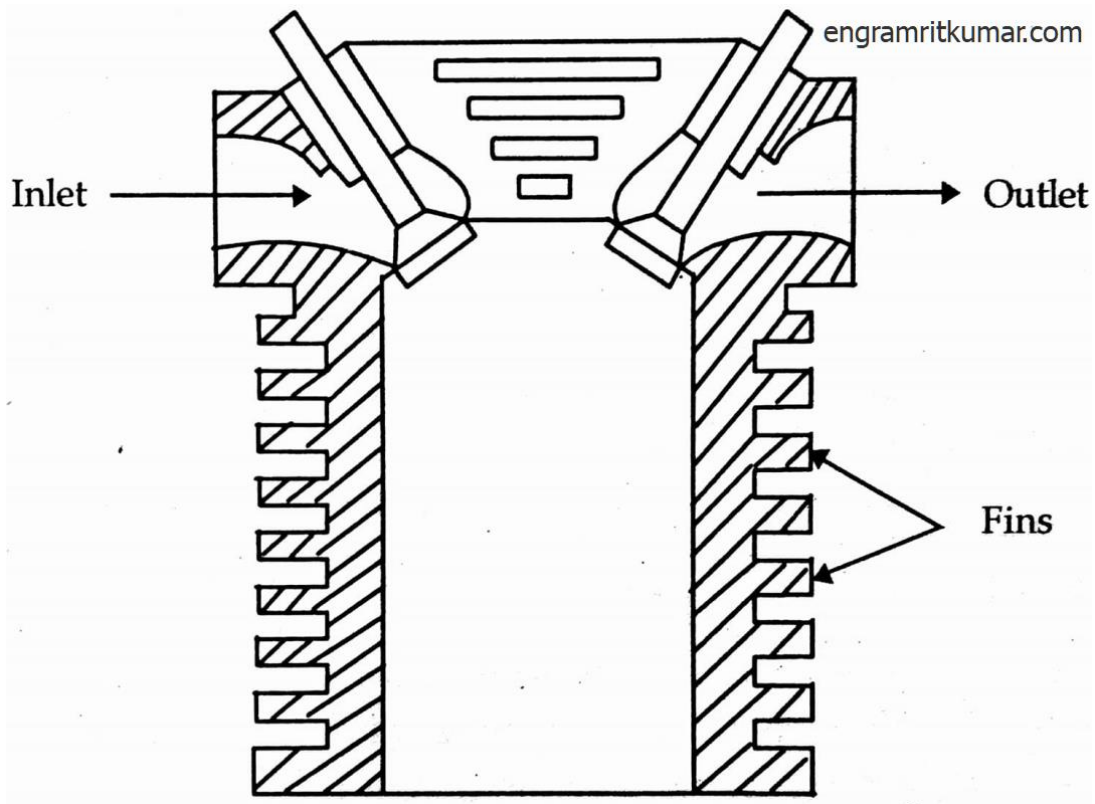

Figure 7.1 Air cooling system

#### Advantages of Air Cooled Engines

Air cooled engines have the following advantages:

Its design of air-cooled engine is simple.

- It is lighter in weight than water-cooled engines due to the absence of water jackets, radiator, circulating pump and the weight of the cooling water.
- It is cheaper to manufacture.
- It needs less care and maintenance.
- This system of cooling is particularly advantageous where there are extreme climatic conditions in the arctic or where there is scarcity of water as in deserts.
- No risk of damage from frost, such as cracking of cylinder jackets or radiator water tubes.

### **7.3.2 Water Cooling System**

It serves two purposes in the working of an engine:

It takes away the excessive heat generated in the engine and saves it from overheating.

It keeps the engine at working temperature for efficient and economical working.

This cooling system has four types of systems:

- Direct or non-return system,
- Thermo-Siphon system,
- Hopper system and
- Pump/forced circulation system.

#### **Non-Return Water Cooling System**

This is suitable for large installations and where plenty of water is available. The water from a storage tank is directly supplied to the engine cylinder. The hot water is not cooled for reuse but simply discharges. The low H.P. engine, coupled with the irrigation pump is an example.

#### **Thermo-Siphon Water Cooling System**

This system works on the principle that hot water being lighter rises up and the cold water being heavier goes down. In this system the radiator is placed at a higher level than the engine for the easy flow of water towards the engine. Heat is conducted to the water jackets from where it is taken away due to convection by the circulating water. As the water jacket becomes hot, it rises to the top of the radiator. Cold water from the radiator takes the place of the rising hot water and in this way a circulation of water is set up in the system. This helps in keeping the engine at working temperature. Disadvantages of Thermo-Siphon System

- Rate of circulation is too slow.
- Circulation commences only when there is a marked difference in temperature.
- Circulation stops as the level of water falls below the top of the delivery pipe of the radiator.

### **Hopper Water Cooling System**

This also works on the same principle as the thermo-siphon system. In this there is a hopper on a jacket containing water, which surrounds the engine cylinder. In this system, as soon as water starts boiling, it is replaced by cold water. An engine fitted with this system cannot run for several hours without it being refilled with water.

### **Forced Circulation Water Cooling System**

This system is similar in construction to the thermo-siphon system except that it makes use of a centrifugal pump to circulate the water throughout the water jackets and radiator. The water flows from the lower portion of the radiator to the water jacket of the engine through the centrifugal pump. After the circulation water comes back to the radiator, it loses its heat by the process of radiation. This system is employed in cars, trucks, tractors, etc.

#### **Parts of Forced Circulation Water Cooling System (Figure 7.2):**

The main parts in the water-cooling system are: water pump, fan, radiator, pressure cap, fan belt, water jacket, thermostat valve, temperature gauge and hose pipes.

#### **Water Pump**

This is a centrifugal type pump. It is centrally mounted at the front of the cylinder block and is usually driven by means of a belt. This type of pump consists of the following parts: (i) body or casing, (ii) impeller (rotor), (iii) shaft, (iv) bearings, or bush, (v) water pump seal and (vi) pulley. The bottom of the radiator is connected to the suction side of the pump. The power is transmitted to the pump spindle from a pulley mounted at the end of the crankshaft.

Seals of various designs are incorporated in the pump to prevent loss of coolant from the system.

#### **Fan**

The fan is generally mounted on the water pump pulley, although on some engines it is attached directly to the crankshaft. It serves two purposes in the cooling system of an engine.

It draws atmospheric air through the radiator and thus increases the efficiency of the radiator in cooling hot water. It throws fresh air over the outer surface of the engine, which takes away the

heat conducted by the engine parts and thus increases the efficiency of the entire cooling system.

### Radiator

The purpose of the radiator is to cool down the water received from the engine. The radiator consists of three main parts:

- upper tank
- lower tank
- tubes.

Hot water from the upper tank, which comes from the engine, flows downwards through the tubes. The heat contained in the hot water is conducted to the copper fins provided around the tubes. An overflow pipe, connected to the upper tank, permits excess water or steam to escape.

### Thermostat Valve

It is a kind of check valve which opens and closes with the effect of temperature. It is fitted in the water outlet of the engine. During the warm-up period, the thermostat is closed and the water pump circulates the water only throughout the cylinder block and cylinder head. Standard thermostats are designed to start opening at 70 to 75°C and they fully open at 82°C. High temperature thermostats, with permanent anti-freeze solutions (Prestine, Zerex, etc.), start opening at 80 to 90°C and fully open at 92°C.

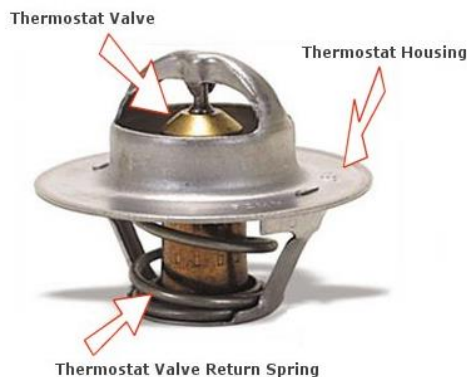

**Figure 7.2a** Thermostat valve

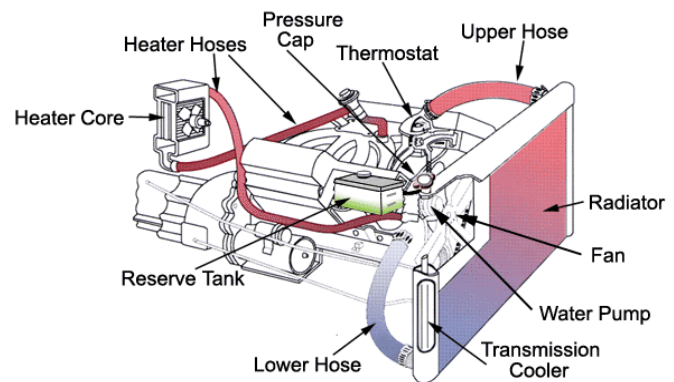

**Figure 7.2b** Forced Circulation Water Cooling

### Anti-Freeze Solutions

In order to prevent the water in the cooling system from freezing, some chemical solutions which are known as anti-freeze solutions are mixed with water. In cold areas, if the engine is

kept without this solution for some time, the water may freeze and expand leading to fractures in the cylinder block, cylinder head, pipes and/or radiators. The boiling point of the anti-freeze solution should be as high as that of water. An ideal mixture should easily dissolve in water, be reasonably cheap and should not deposit any foreign matter in the jacket pipes and radiator. No single anti-freeze solution satisfies all these requirements. The materials commonly used are wood.

## 7.4 Lubrication System

I. C. engine is made of many moving parts. Due to continuous movement of two metallic surfaces over each other, there is wearing moving parts, generation of heat and loss of power in the engine lubrication of moving parts is essential to prevent all these harmful effects.

Lubrication helps in:

- **Reducing friction** - The primary purpose of the lubrication is to reduce friction and wear between two rubbing surfaces. Two rubbing surfaces always produce friction. The continuous friction produce heat which causes wearing of parts and loss of power. In order to avoid friction, the contact of two sliding surfaces must be reduced as far a possible. Lubrication forms an oil film between two moving surfaces. Lubrication also reduces noise produced by the movement of two metal surfaces over each other.
- **Cooling engine** -The heat, generated by piston, cylinder, and bearings is removed by lubrication to a great extent. Lubrication creates cooling effect on the engine parts.
- **Sealing effect** - The lubricant enters into the gap between the cylinder liner, piston and piston rings. Thus, it prevents leakage of gases from the engine cylinder.
- **Cleaning engine** - Lubrication keeps the engine clean by removing dirt or carbon from inside of the engine along with the oil.

### Types of Lubricants

Lubricants are obtained from animal fat, vegetables and minerals Lubricants made of animal fat, does not stand much heat. It becomes waxy and gummy which is not very suitable for machines.

**Vegetable lubricants** – These are obtained from seeds, fruits and plants. Cottonseed oil, olive oil, linseed oil and castor oil are used as lubricant in small Simple machines.

**Mineral lubricants** – These are most popular for engines and machines. It is obtained from crude petroleum found in nature. Petroleum lubricants are less expensive and suitable for internal combustion engines.

A good lubricant should have the following qualities:

- It should have sufficient viscosity to keep the rubbing surfaces apart
- It should remain stable under changing temperatures.
- It should keep lubricated parts clean.
- It should not corrode metallic surfaces.

### **Engine Lubricating System**

The lubricating system of an engine is an arrangement of mechanism and devices which maintains supply of lubricating oil to the rubbing surface of an engine at correct pressure and temperature. The parts which require lubrication are:

- 1) cylinder walls
- 2) piston and piston pin
- 3) crankshaft
- 4) connecting rod bearings
- 5) camshaft bearings
- 6) valves and valve operating mechanism
- 7) cooling fan
- 8) water pump
- 9) ignition mechanism.

There are three common systems of lubrication used on stationary engines, tractor engines and automobiles:

- Splash system
- Forced feed system
- Combination of splash and forced feed system.

### **Splash System**

In this system, there is an oil trough, provided below the connecting rod (Figure 7.3). Oil is maintained at a uniform level in the oil trough. This is obtained by maintaining a continuous flow of oil from the oil sump or reservoir into a splash pan, which has a depression or a trough like arrangement under each connecting rod. This pan receives its oil supply from the oil sump either by means of a gear pump or by gravity. A dipper is provided at the lower end of the connecting rod. This dipper dips into to oil trough and splashes oil out of the pan. The splashing action of oil maintains a fog or mist of oil that drenches the inner parts of the engine such as

bearings, cylinder walls, pistons, piston pins, timing gears etc. This system is usually used on single cylinder engine with closes crankcase. For effective functioning of the engine, proper level of oil be maintained in the oil pan. Lubrication depends largely upon the size of oil holes and clearances. This system is very effective if the oil is clean and undiluted. Its disadvantages are that lubrication is not very uniform and when the rings are worn, the oil passes the piston into combustion chamber, causing carbon deposition, blue smoke and spoiling the plugs. There is every possibility that oil may become very thin through crankcase dilution. The Splash lubrication system worn metal, dust and carbon may be collected in the oil chamber and be carried to different parts of the engine, causing wear and tear.

## Splash System

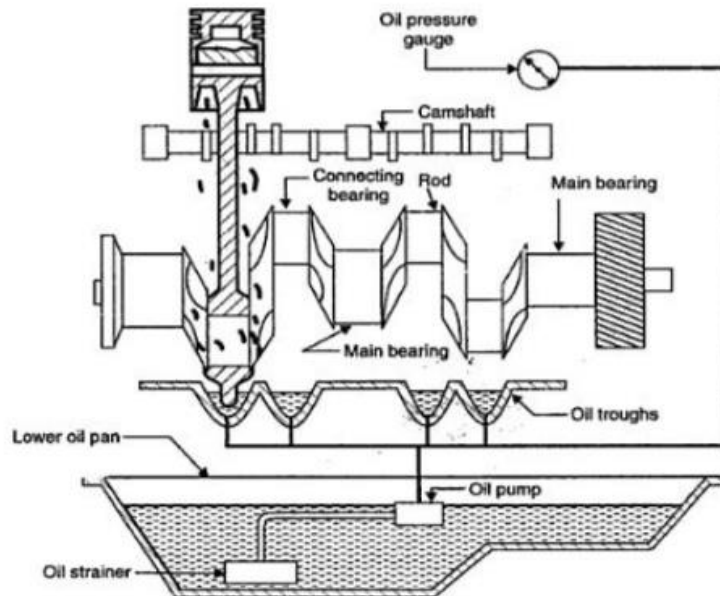
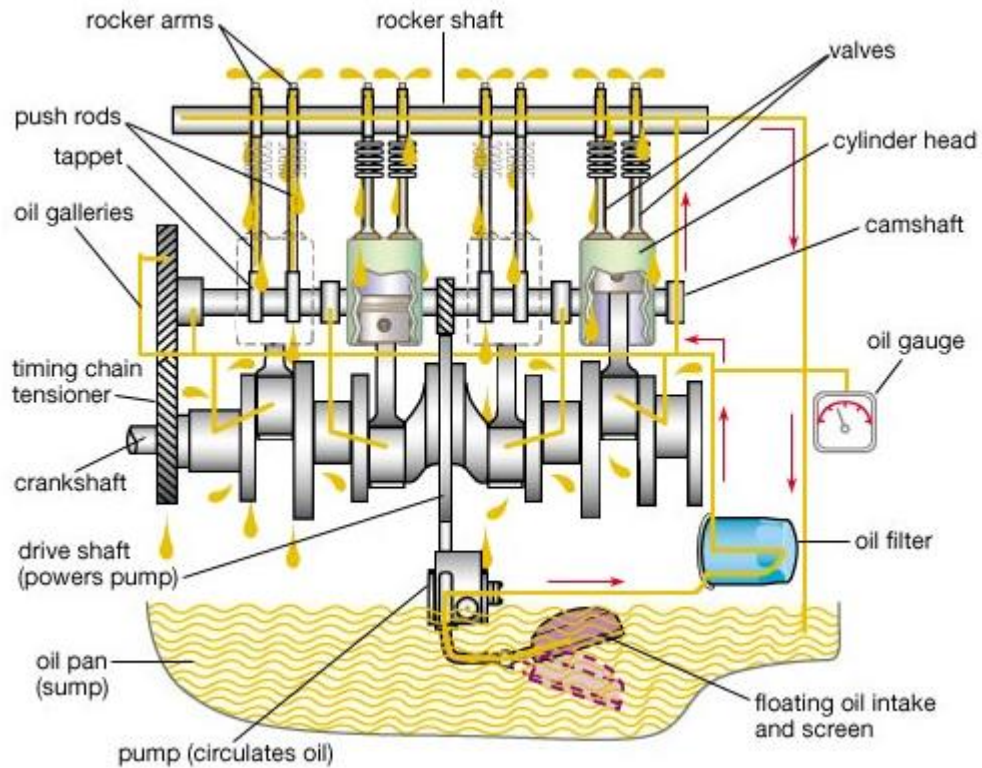

**Figure 7.3 Splash System**

### **Forced Feed System**

In this system, the oil is pumped directly to the crankshaft, connecting rod, piston pin, timing gears and camshaft of the engine through suitable paths galleries of oil. Usually the oil first enters the main gallery in the crankcase casting. From there, it goes to each of the main bearings through holes. From main bearings, it goes to big end bearings of connecting rod through drilled holes in the crankshaft. From there, it goes to lubricate the walls, pistons and rings. There is separate oil gallery to lubricate timing gears. Lubricating oil pump is a positive displacement

pump, usually gear type or vane' type. The oil also goes to valve stem and rocker arm shaft under pressure through an oil gallery. The excess oil comes back from the cylinder head to the crankcase. The pump discharges oil into oil pipes or oil galleries leading different parts of the engine. This system is commonly used on high speed multi-cylinder engine in tractors, trucks and automobiles.



**Figure 7.4 Forced feed system**

### **Combination of Splash and Forced Feed System**

In this system, the engine component, which are subjected to very heavy load are lubricated under forced pressure, such as main bearing connecting rod bearing and camshaft bearing. The rest of the parts like cylinder liners, cams, tappets etc are lubricated by splashed oil.

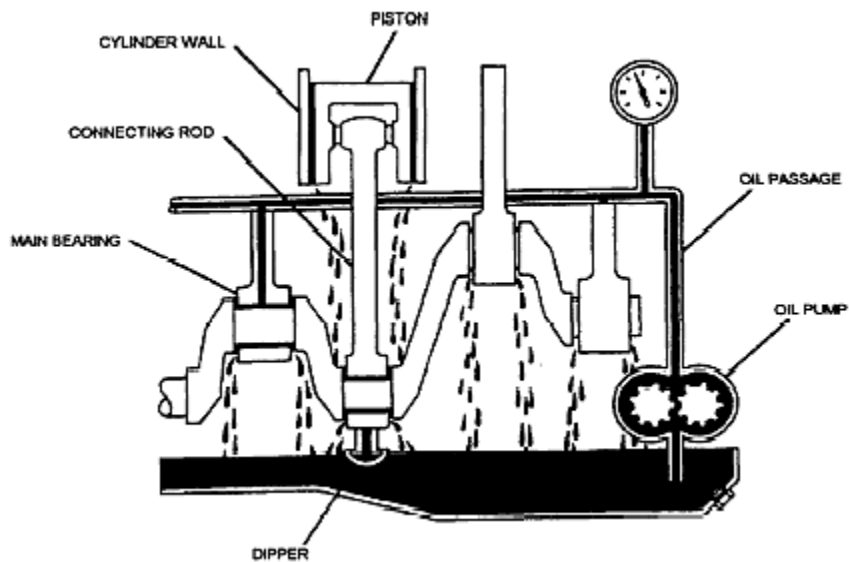

**Figure 7.5 Combination of Splash and Forced Feed System**

- a) **Oil pump:** Oil pump is usually a gear type pump, used to force oil into the oil pipe. The pump is driven by the camshaft of the engine. The lower end of the pump extends down into the crankcase which is covered with a screen to check foreign particles. A portion of the oil forced to the oil filter and the remaining oil goes to lubricate various parts of the engine. An oil pressure gauge fitted in the line, indicates the oil pressure in the lubricating system. About  $3 \text{ kg/cm}^2$  (45 psi) pressure is developed in the lubrication system of a tractor engine. If the oil pressure gauge indicates no pressure in the line, there is some defect in the system which must be checked immediately. Lubricating oil pump is a positive displacement pump.
- b) **Oil Filter:** Lubricating oil in an engine becomes contaminated with various materials such as dirt, metal particles and carbon. Oil filter removes the dirty elements of the oil in an effective way. It is a type of Forced feed lubrication system strainer using cloth, paper, felt, wire screen or similar elements. Some oil filter can be cleaned by washing, but in general old filters are replaced by new filters at specified interval of time prescribed by manufacturers. Wearing of parts, oil consumption and operating cost of an engine can be considerably reduced by proper maintenance of oil filters. Oil filters may be Full-flow filter or By-pass filter.
- c) **Full flow filter:** In this filter the entire quantity of oil is forced to circulate through it before it enters the engine. A spring loaded valve is usually fitted in the filter as a protection device against oil starvation in case of filter getting clogged. Filter element consists of felt, cloth, paper and plastic. All these elements are replaceable and should be changed after the recommended period.

- d) **By pass filter:** In this type of filter, the supply lines are from the pump and are connected to permit only a part of the oil. Through the filter the balance oil reaches directly to the engine parts. Over a period of operation, all the oil in the crankcase passes through the filter.
- e) **Oil pressure gauge:** Oil pressure gauge is used to indicate the oil pressure in the oil lines. It serves to warn the operator of any irregularity in the system.
- f) **Crankcase breather:** The engine crankcase is always fitted with some kind of breather, connecting the space above the oil level with the outside atmosphere. The purpose of the breather is to prevent building up pressure in the crankcase.
- g) **Relief valve:** Relief valve is provided to control the quantity of oil circulation and to maintain correct pressure in the lubricating system.

### **Care and maintenance of lubrication system**

The following are few suggestions for good lubrication system:

- a) A good design of oil circulation system should be chosen.
- b) Correct grade of lubricant ensures long and trouble free service.
- c) Oil should be maintained at desired level in the oil chamber.
- d) Oil should be cleaned regularly and after specified period of use, old filters should be replaced by new filters.
- e) Connections, piping, valves and pressure gauge should be checked regularly.
- f) Oil should be changed regularly after specified interval of time. Before putting the new oil, the crankcase should be cleaned and flushed well with a flushing oil.
- g) Precautions should be taken to keep the oil free from dust and water.

**CHAPTER-8****TRACTOR POWER TRANSMISSION SYSTEM**

*By*

*Engr. Prof. Dr. Muhammad Iqbal, Subject Expert  
Engr. Dr. Muhammad Azam Khan, Assoc. Professor*

Transmission is a speed reducing mechanism, equipped with several gears (Fig. 8.1). It may be called a sequence of gears and shafts, through which the engine power is transmitted to the tractor wheels. The system consists of various devices that cause forward and backward movement of tractor to suit different field condition. The complete path of power from the engine to the wheels is called power train. The main functions of this system are:

- Power transmission from the engine to the rear wheels of the tractor
- Speed reduction at rear wheels of the tractor
- Alteration in the ratio of wheel speed and engine speed in order to suit the field conditions
- Power transmission through right angle drive, because the crankshaft and rear axle are normally at right angles to each other.

Components of power transmission system are:

- Clutch
- Transmission gears
- Differential
- Final drive
- Rear axle
- Rear wheels.

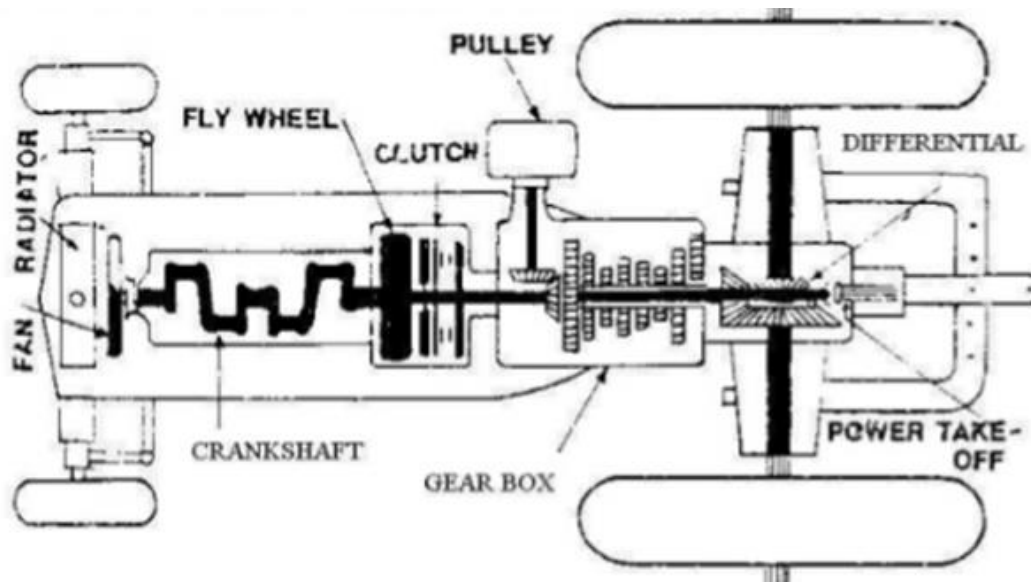

**Figure 8.1 Power Transmission system of Tractor**

### 8.1 Clutch

Clutch is a device that engages and disengages power from the engine to the transmission. It should have following features:

- It should have good ability for taking load without dragging and chattering.
- It should have higher capacity to transmit maximum power without slipping.
- Its friction surface should be highly resistant to heat effect.
- Its control by hand lever or pedal lever should be easy.

#### Types of Clutch

- Friction clutch
- Dog clutch
- Fluid coupling.

**Friction Clutch** - Friction clutches are used to transmit torque by using the surface friction between two faces of the clutch (Figure 8.2).

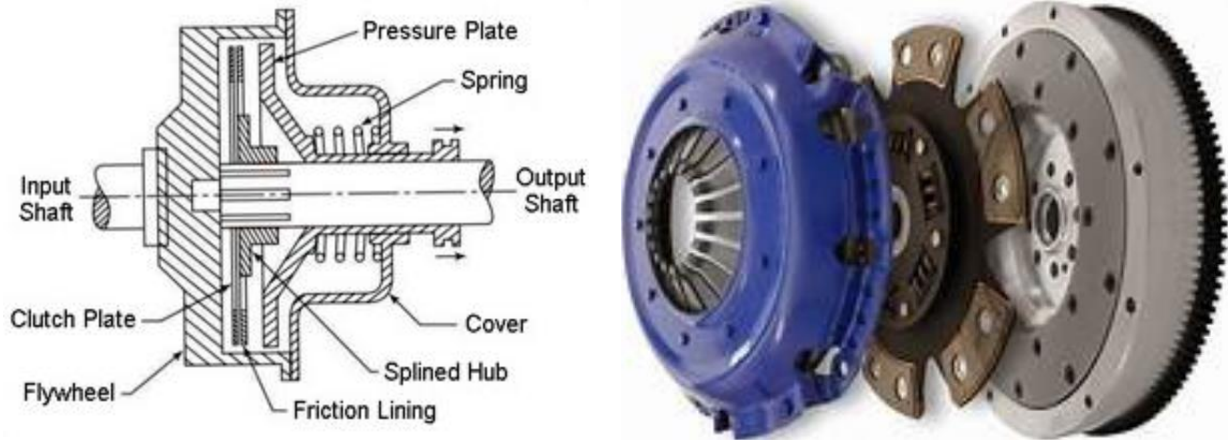

**Figure 8.2 Friction clutch**

**Dog Clutch** - This clutch couples two rotating shafts or other rotating components not by friction, but by interference (Figure 8.3). Both the parts of the clutch are designed so that one pushes into the other, causing both to rotate at the same speed, so that they never slip.



**Figure 8.3 Dog clutch**

**Fluid coupling** - It is hydrodynamic device that is used for rotating mechanical power transmission (Figure 8.4). There is no mechanical contact between driving and driven shafts. Power from one shaft is transmitted to another shaft with the help of fluid / oil.

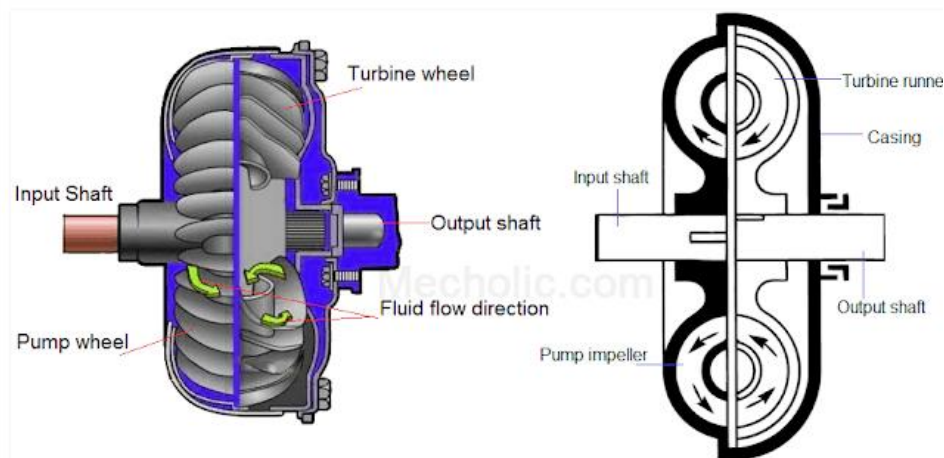

**Figure 8.4 Fluid coupling**

## 8.2 Transmission Gears and Torque Converter Gear

A tractor engine runs at high speed, but the rear wheel of the tractor requires power at low speed and high torque. That's why it becomes essential to reduce the engine speed and increase the torque available at the rear wheels of the tractor because

$$BHP = \frac{2\pi NT}{4500} \text{ --- 8.1}$$

Where, BHP is brake horse power, T is torque in kg-m and N is rev/min.

If the engine hp is constant, it is obvious that for higher torque at wheels, low speed is required and vice versa. So the gearbox is fitted between engine and rear wheel for variable torque and speed. This is done by suitable design of gear and shafts (Fig. 4). Speed varies according to the field requirements and so a number of gear ratios are provided to suit the varying conditions. Gears are usually made of alloy steel. As the tractor has to transmit heavy torque all the time, -best quality lubricants free from sediments, grit, alkali and moisture, is used for lubrication purpose. SAE 90 oil is generally recommended for gearbox. Common gears used on tractors are of two types viz; (i) Selective sliding type and (ii) Constant mesh type.

(i) Selective sliding type: The gear box consists of: (i) gear housing (ii) gear shifting lever (iii) main shaft or input shaft (iv) output shaft and (v) lay shaft or countershaft.

A number of gears are mounted on these shafts. The main shaft is directly connected to the clutch and carries gears. The gears are liable to slide. The gears are shifted with the help of shifting lever and shifting fork. The gears are shifted along the shaft, to which they are splined to engage with another gear as and when desired to connect the power train. The gears are of different diameters having different number of teeth. Speed is reduced in proportion to the number of teeth provided on the gears.

(ii) Constant mesh type: These gears are always in mesh. Usually the gears are helical in shape. The transmission is put into operation by engagement of shifting couplings, which slide along the splines on the countershaft and the output shaft of the gear box.

## 8.3 Differential Unit and Final Drive

Differential: Differential unit is a special arrangement of gears to permit one of the rear wheels of the tractor to rotate slower or faster than the other (Figure 8.5). While turning the tractor on a curved path, the inner wheel has to travel lesser the tractor to move faster than the

other at the turning point. The output shaft coming from the gear box is provided with a bevel pinion at the end of the shaft.

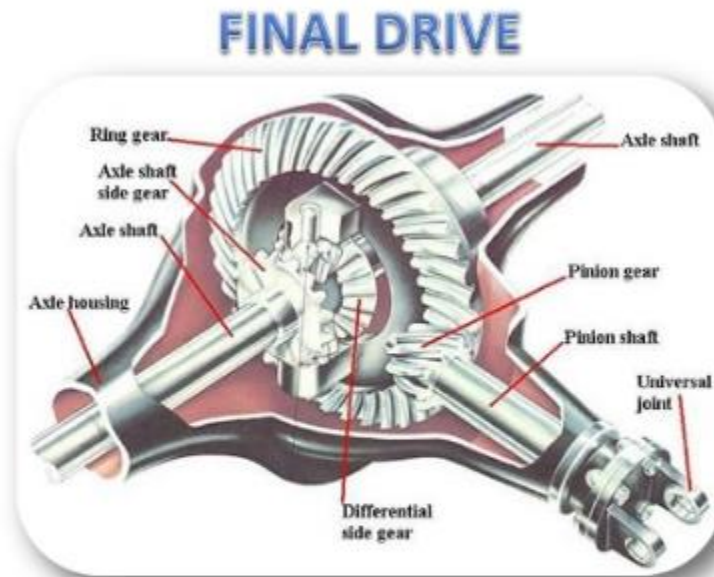

To transmit the power to the wheels while allowing them to rotate at different speeds. Also as the final gear reduction in the vehicle, slowing the rotational speed of the transmission

**Figure 8.5 Differential and Final drive**

The bevel pinion is in mesh with a large bevel wheel known as crown wheel. The main functions of crown wheel assembly are:

- (i) to transmit power through right angle drive to suit the tractor wheels.
- (ii) to reduce the speed of rotation.

The differential unit consists of: (i) differential casing (ii) differential pinion (iii) crown wheel (iv) half shaft and (v) bevel gear.

The differential casing is rigidly attached with the crown wheel and moves like one unit. Two pinions are provided inside the differential casing, such that they are carried round by the crown wheel but they are free to rotate also on their own shaft or stud. There are two or more bevel gears in mesh with differential pinion. One bevel pinion is at the end of each half shaft, which goes to the tractor rear wheel. Thus instead of crown wheel being keyed directly to a solid shaft between the tractor wheels, the drive is taken back from the indirect route through differential casing, differential pinion and half shaft of the tractor. When the tractor is moving in a straight line, the differential pinion do not rotate on the stub shaft but are solid with the

differential casing. They drive the two bevel gears at the same speed and in the same direction as the casing and the crown wheel. Each differential pinion can move in two planes simultaneously. When it is carried round by the casing, it drives the half-shaft in the same direction but when it is rotated on its own shaft, it drives them in opposite direction i. e. rotation of differential pinion adds motion to one shaft and subtracts motion from the other shaft.

**Differential lock:** Differential lock is a device to join both half axles of the tractor so that even if one wheel is under less resistance, the tractor comes out from the mud etc as both wheels move with the same speed and apply equal traction.

**Final drive:** Final drive is a gear reduction unit in the power trains between the differential and the drive wheels. Final drive transmits the power finally to the rear axle and the wheels. The tractor rear wheels are not directly attached to the half shafts but the drive is taken through a pair of spur gears. Each half shaft terminates in a small gear, which meshes with a large gear called bull gear. The bull gear is mounted on the shaft, carrying the tractor rear wheel. The device for final speed reduction, suitable for tractor rear wheels is known as final drive mechanism.

#### **8.4 Steering System and Brake Steering System**

The system, governing the angular movement of front wheels of a tractor is called steering system. This system steering wheel minimizes the efforts of the operator in turning the front wheel with the application of leverages. The different components of the system are: (i) steering wheel (ii) steering shaft (iii) steering gear (iv) pitman arm (drop arm) (v) drag link (vi) steering arm (vii) tie rod and (viii) king pin.

When the operator turns the steering wheel, the motion is transmitted through the steering shaft to the angular motion of the pitman arm, through a set of gears. The angular movement of the pitman arm is further transmitted to the steering arm through the drag link and tie rods. Steering arms are keyed to the respective king pins which are integral part of the stub axle on which wheels are mounted. The movement of the steering arm affects the angular movement of the front wheel. **In** another design, instead of one pitman arm and drag link, two pitman arms and drag links are used and the use of tie rod is avoided to connect both steering arms.

#### **8.5 Brake**

Brake is used to stop or slow down the motion of a tractor. It is mounted on the driving axle and operated by two independent pedals. Each pedal can be operated independently to assist the turning of tractor during the fieldwork or locked together by means of a lock.

**Principle of operation:** Brake works on the principle of friction. When a moving element is brought into contact with a stationary element, the motion of the moving element is affected. This is due to frictional force, which acts in opposite direction of the motion and converts the kinetic energy into heat energy.

**Classification of brake:** Brake can be classified as: (1) Mechanical brake (a) Internal expanding shoe type (b) External contracting shoe type and (c) Disc type and (2) Hydraulic brake.

**(a) Internal expanding shoe type:** Two brake shoes made of frictional material fitted on the inside of the brake drum are held away from the drum by means of springs. One end of each shoe is fulcrumed whereas the other is free to move by the action of a cam, which in turn applies force on the shoes. The movement of the cam is caused by the brake pedal through the linkage. The drum is mounted on the rear axle whereas the shoe assembly is stationary and mounted on the back plate.

**(b) External contracting shoe type:** This type of brake system is normally available on crawler tractors. The drum mounted on the drive axle is directly surrounded by the brake band. When the pedal is depressed, the band tightens the drum.

**(c) Disc brake:** Two actuating discs have holes drilled in each disc in which steel balls are placed. When the brake pedal is depressed, the links help to move the two discs in opposite directions. This brings the steel balls to shallow part of the holes drilled in the disc. As a result, the two discs are expanded and braking discs are pressed in between the discs and the stationary housing. The braking discs are directly mounted on the differential shaft which ultimately transfers the travelling effect to the differential shaft.

**Hydraulic brake:** Hydraulic brake system is based on the principle of Pascal's law. The brake fluid which is usually a mixture of glycerin and alcohol is filled in the master cylinder. When the pedal is depressed, the piston of the master cylinder is forced into the cylinder and the entire system turns to a pressure system. Immediately, the piston of the wheel cylinder slides outward which moves the brake shoes to stop the rotating drum. When the pedal is released, the return spring of the master cylinder moves the piston back to its original position, causing a sudden pressure drop in the line. The retracting springs of the brake shoe bring them back to their original position. Thus the piston of the wheel cylinder returns back.

## 8.6 Hydraulic Control System

It is a mechanism in a tractor to raise, hold or lower the mounted or semi-mounted equipments by hydraulic means (Figure 8.6).

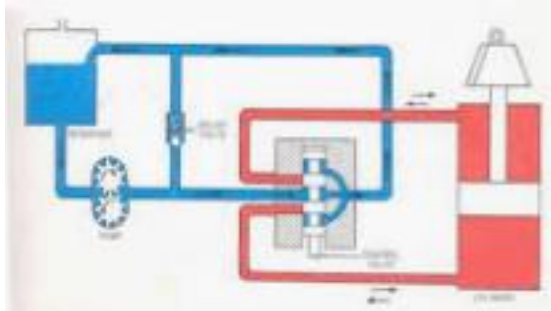

Figure 8.6 **Hydraulic Control System**

**Working principle:** The working principle of hydraulic system is based on Pascal's law. This law states that the pressure applied to an enclosed fluid is transmitted equally in all directions. Small force acting on small area can produce higher force on a surface of larger area.

A simple hydraulic system consists of a pump which pumps oil to a hydraulic ram. This pump may be driven from tractors transmission system or it may be mounted on its engine. This system consists of a cylinder with a close fitting piston like an engine cylinder. As the oil is pumped into the closed end of the cylinder, the piston is forced along with it. The movement of the piston is transmitted to the lower links by means of a cross shaft and lift rods. A control valve controls the flow of oil and directs it back to the reservoir. It allows the oil in the cylinder to flow out again when the links are to be lowered. It also traps the oil in the cylinder when the links are to be held at any height.

### **Basic Components of Hydraulic System**

The basic components of Hydraulic System are: (i) Hydraulic pump (ii) Hydraulic cylinder and piston (iii) Hydraulic tank (iv) Control valve (v) Safety valve (vi) Hose pipe and fittings and (vii) Lifting Arms (Figure ).

**Operation:** The hydraulic pump draws up oil from the oil reservoir and sends it to the control valve under high pressure. From the control valve, the oil goes to the hydraulic cylinder to operate the piston, which in turn, raises the lifting arms. The lifting arms are attached with implements. The hydraulic pump is operated by suitable gears, connected with engine.

There are two types of arrangements for storing hydraulic oil in the system : (i) There is a common oil reservoir for hydraulic system and the transmission system in some tractors, (ii) There is a special tank for hydraulic oil. It is separate from' the transmission chamber.

## 8.7 Tractor Hitch

Implements are needed to be hitched properly for efficient and safe operation of the tractor.

Implements can be; (i) Trailed (ii) Semi mounted and (iii) Mounted. Implements can be hitched in two ways: (a) Drawbar hitch and (b) Three point linkage.

1. **Drawbar hitch:** Drawbar is a device by which the pulling power of the tractor is transmitted to the trailing implements. It consists of a crossbar with suitable holes, attached to the lower hitch links. It is fitted at the rear part of the tractor.
2. **Three point linkage:** It is a combination of three links, one is upper link and two are lower links, the links articulated to the tractor and the implements at their ends in order to connect the implement to the tractor.

**Advantage of three point linkage ;** (1) Easy control of working implements (2) Quick setting of implements (3) Automatic hydraulic control of implements such as position control, draft control etc. (4) Good balancing of attached implements.

### 8.7 Power Take-Off Unit (PTO)

The PTO is a part of tractor transmission system (Figure 8.7). It consists of a shaft, a shield and a cover. The shaft is externally splined to transmit torsional power to another machine. A rigid guard fitted on a tractor covers the power take-off shaft as a safety device. This guard is called power take-off shield. Agricultural machines are coupled with this shaft at the rear part of the tractor. As per ASAE standard PTO speed is  $540 \pm 10$  rpm when operating under load. In order to operate 1000 rpm PTO drive machine, a new standard has been developed.



**PTO on a tractor**



**PTO drive**

**Figure 8.7 Tractor PTO shaft**

## 8.8 Belt Pulley

All tractors are provided with a belt pulley (Figure 8.8). The function of the pulley is to transmit power

from the tractor to stationary machines by means of a belt. It is used to operate thresher, centrifugal pumps, silage cutter and several other machines. The pulley is located either on the left, right or rear side of the tractor. The pulley drive is engaged or disengaged from the engine by means of a clutch. The pulley is generally made of cast iron.



**Figure 8.8 Belt pulley connected to tractor PTO**

## LAND DEVELOPMENT

By

*Engr. Mumtaz Ahmad, Subject Expert*

### Introduction

Land is the most critical resource in rural poor dependent on farming for their lively hood. Today about two million hectares of rain fed and irrigated agricultural lands have lost production every year due to land degradation and other factors. Therefore, there is dire need to bring new available uncultivated areas under cultivation. For this purpose land development activities are the almost need of the time. The land development may be defined as the conversion of land from one farm to the other is generally accepted definition of land development. However, the land development concept carries the meanings of landscape change for multiple purposes such as:

1. Change land forms from natural are sami-natural states for a purpose of agriculture or housing.
2. Division of real states in to lots typically for house building.
3. Changing unused property into useful dominions etc.

The objectives of above activities are definitely to maximize the profits to the developers. The definition of land development is confined to land conversion associated with land utilization for agriculture. The land development process began when ancient societies organized themselves in to tribes “settling on and claiming land, farming villages and primitive towns for the mutual protection and lively hood for all.

Today the process of finding solutions and developing scenario for land use that serve the greater good is a systematic one and is to a large degree uniform in principle and practice. Another term in this regard is used that is land development design. The systematic approach to land use planning, analysis and engineering is known as land development design. The land development design and consulting constitute the systematic process of collecting data, studying data and understating data, extrapolating the data and creating on paper the plans for reshaping the land to yield a land development project.

Conversing of land shape for agricultural purposes is over main emphasis in this chapter. The land development initially starts from clearing of rural lands involving the use of heavy

machines which fulfill the job of removal of all types of vegetations, and obstructions on the land surfaces like bushes, trees, sand dunes and rocks. All land clearing and endeavors aims at the development of land and utilization of unused land for enhance of total cultivated area and finally increasing the per capital income of the rural poor.

### **Strategies/planning for land development**

Land development process is critically planned according to the following phases:

Phases-I: Land clearing

Phase-II: Soil opening and earth moving

Phase-III: Field bundings, making water channels etc.

### **Land development machinery**

Land farming is the highly cost intensive operation informing. The process involve the jungle clearness, soil opening with deep tillage equipment, moving the soil form high parts to the lowest parts, making form roods, field bundings and leveling. The theses operations require the use of self propelled heavy equipments/ machines such as bulldozers, excavators, crawler tractors, heavy duty plow, big horse power tractors with dozing and hoeing attachments, scrapers, ditchers, sub soilers, terracers and levelers etc. In any land development operation the following types of machines are used for accomplishing different types of job assignments.

#### **1. Bulldozers**

##### **Salient features:**

A crawler machine which is continues tracked tractor with a substantial metal plate called blade. The machine is engaged for heavy earth works such as sand dunes, rubble or other such materials during construction works or conservation works. It is typically equipped at the rear with a claw like device known as ripper to loosen the densely compacted materials. It can be seen working on mines, quarries, military bases, heavy industry factories, engineering projects and farms.

The bulldozers are large power full heavy equipment is with wide enough tracks which give it ground holding capacity and mobility through very rough terrains. The Vidal tracks are

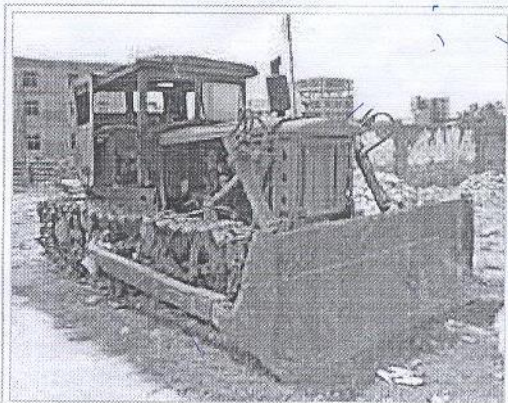

A working bulldozer from the First Tractor Company, on Xinbu Island, Hainan, China.

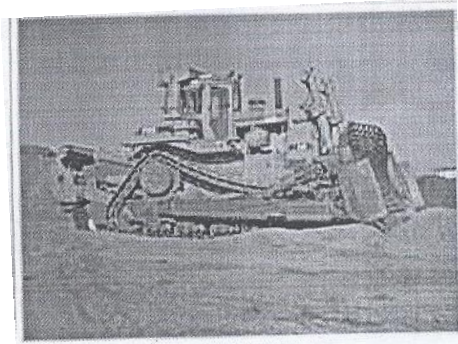

A Caterpillar D10N bulldozer equipped with a single shank ripper.

provided for more traction are known as swamps. Thus protecting it from sinking in sandy and muddy soil. The bulldozer is design to convert the engine power into improve dragging ability. A crawler dozer some time is referred to as tracked are cater pillar has a traction mechanism like that of Sami rigid, suspension car. The steering is hydraulically assisted.



Multi-shank ripper

Most of crawler bulldozers are powered by diesel engine which makes the work energy efficient. This type of bulldozer is used for sludge construction, field modifications, port and mine development. The other type is wheeled bulldozer also called as wheeled dozer. The principle machine work is to push out fitted dozer blades by essentially tractors so as to cleaning and grading lands are paying the roads. These machines are big tractive force, high efficiency and good performance. It is all wheel drive and easy to operate. The bulldozer is preliminary provided with blade and ripper. The bulldozer blade is a heavy metal plate on the front used to push the materials. The dozer blades may be of the following types;

1. “S” blade – straight short and have no lateral curve and side wings and used for fine grading.

2. “U”blade – which is tall curve and has large wings to carry the materials
3. “SU” blade – shorter less curvature and small side wings used for pushing of piles of large rocks.

The blade can be used straight across the frame at an angle sometimes using additional cylinders to vary the angle while moving. The bottom edge of the blade can be sharpened.

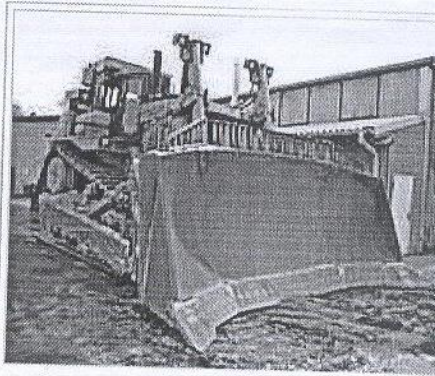

Bulldozer blade

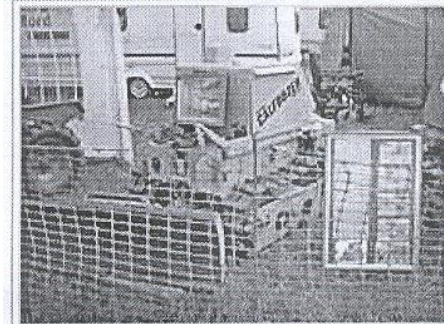

Aveling-Barford *Calfdozer* compact bulldozer

Another important component of the bulldozer is ripper which is a claw like device at the back of the bulldozers and they may be single shank or multi shank rippers. Single shank rippers are preferred for heavy ripping work and a fitted with a replaceable tungsten steel alloy tip. The bulldozer ripper can break the old lava flows and the growersshatters lava with heavy bulldozers to plant surface crops. A bulldozer with an attachment known as stamp buster can be used for land clearing operations.

## 2. Excavators

### Salient features:

Excavators are the heavy construction equipment which is consisted of the following components:

1. Boom
2. Stick
3. Bucket
4. Cab
5. Plate form
6. Under carriage with tracks and wheels (house)

A cable operated excavator uses winches and steel ropes to accomplish the movement. All movement and functions of a hydraulic excavator are accomplished through the use of hydraulic

fluid with hydraulic cylinder and hydraulic motors due to the linear actuation of the hydraulic cylinders their mode of operation is fundamental different from the cable operated excavator.

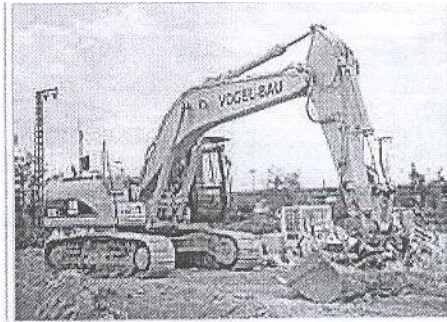

A typical modern excavator:  
a CAT 325C, fitted with quick  
coupler and tilting bucket.

They are sometimes named as diggers, mechanically shovels or 360 degree excavators. Tracked excavators are sometimes called “track hoe”. The excavator are used in many ways such as

- Digging of trenches, holes, foundations
- Material handling
- Brush cutting with hydraulic attachment
- Forestry work
- Demolitions
- General grading, landscaping
- Heavy lift like lifting and placing of pipes

### **Back Hoe Dozer**

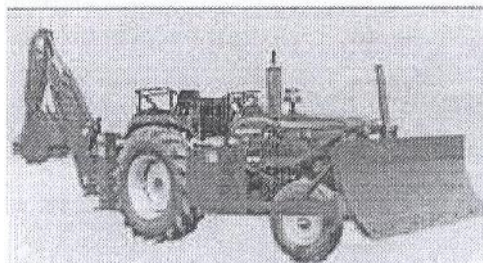

These are two attachments namely backhoe and dozer which are attached to the tractor. The dozers are attached at the front of the tractor and the backhoe is attached to the rear of the tractor. Moreover, these two attachments can be attached and detached readily can be attached and detached from the tractor. The dozer consists of the following components;

- Thick curved plate and hardened strip
- Sharp cutting edge
- Fasteners

The strip can be replaced on wearing are becoming blunt. The dozer plate is joined to the tractor with sturdy arms and can be raised or lowered with hydraulic system of the tractor. The backhoe consists of;

- Bucket with digging fingers
- Hydraulic cylinders
- Arms and base for attaching to the rear of the tractor

The backhoe position is manipulated by hydraulic system and the digging figures are hardened and replaceable on wearing.

#### **Uses:**

The backhoe is used for excavating soil, making foundations for buildings, making trenches for pipes and cable laying, garbage handling, widening of rural roads, and removal of bushes and trees. The dozers used for agricultural land leveling, making bunds on the farms and terracing of farms, road making and site clearance for trench filling at the dams project after laying pipes and cables.

#### **Backhoe Loader**

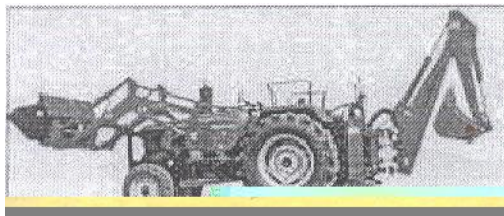

These are also attachments of the tractors. It is a heavy equipment vehicle that consists of a tractors fitted with a shovel or bucket on the front and a small backhoe on the rear. These are very commonly used machine due to small size and versatility. The urban engineers use frequently this type of machine at relatively small construction projects like small houses and roads etc. The backhoe are not used for towing and also do not have power take off. When the backhoe is permanently attached, the machine usually has a seat which can swivel to the rear to face the hoe controls. There are possibilities to attach the removable backhoe which has separate seat on the attachment itself.

**Uses:**

- Used for wide variety of jobs as small constructions and demolition jobs, for light transportation of building materials, digging of pools excavations and landscaping etc. It can also be used for pavement work on the roads. As well as for removal of mud and loose soil on canal work site.

This is a versatile type of machine which can be changed to many other applications with little difficulty. Especially it is relatively small frame and precise control make it very useful and common in urban engineering projects like construction and repairs in areas which are too small for larger equipments. This characteristic makes this machine most popular in urban construction vehicles.

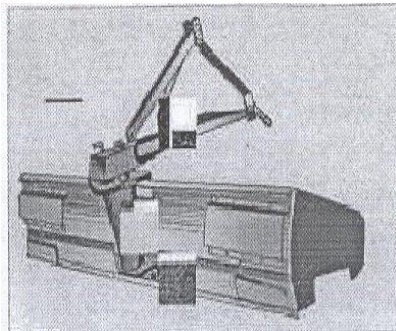
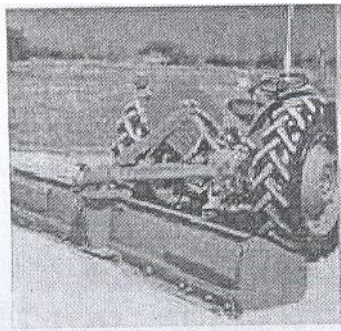
**Tractor mounted terracer blade**

It is a three points linkage attachment with the tractors which is hydraulically control. The major components of the machine are;

- Replaceable blade attached to the curved steel body
- Side wings and indexing arrangements for tilting and angling of blade

The blade can be tilted left or right according to the requirements. To tilt the blade for ditching or terracing it is tilted to the desired angle by moving the index pin. The cutting depth is controlled by hydraulically. The blade can be pitched forward or back or tilted to at 150-300 left or right. It can also be reverse for back filling and the blade can be extended in length by the use of extensions.

**Uses:**

- Used for grading and leveling of fields
- Filling of depressions
- It can handle successfully the job of back filling

This is a front mounted dozer and the dozing blade assembly consists of the curved plate (bucket) to which hardened alloy steel cutting blade is joined with dozer arms, hydraulic cylinders, frame and body. The cutting blade is sharp and fastened to the plate with the fasteners. This is hydraulically controlled and reversible type machine.

### Hydro Dozer

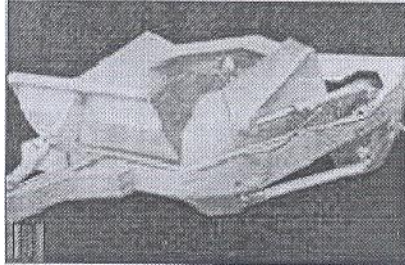

#### Uses:

- It is typically used for land shaping, field terracing, construction of roads, contour bundings etc.

### Hydraulic Scraper

Hydraulic Scraper is towed at the back of the tractor and consists of cutting blade, hydraulic system hitch point and hitch bar, apron, bowl, wheels, apron cylinder and side frame, bucket cylinder, spring and side arms.

The working is controlled by hydraulic arrangements and the blade of alloy steel and hard sharpened. The blade has self sharpening tungsten carbide cutting edge. The scraper accomplishes the work by controlling the bowl filling with sharp blade which penetrates into the soil for its bowl fillings. When the full bucket bowl gets filled the apron is closed and a scraper is moved to the point of unloading. For unloading the bucket is tilted hydraulically.

#### Uses:

- For the collecting the soil from one place and unloading at the other.
- It can also be used for rough leveling, cutting of high spots and filling of depression.

### Sheep Foot Roller

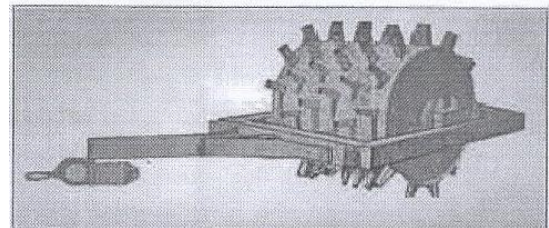
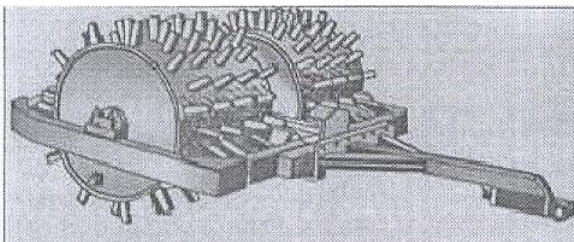

The equipment is available in the form of one or two drums and is attached to the draw bar after tractor. It is provided with adjustable cleaner teeth to prevent accumulation of dirt one roller is mounted on the heavy duty frame. Independent oscillating frame and oscillation stopper are provided in the double drum sheet foot roller.

**Uses:**

- For the compaction of soil and farms roads.

**Cultipacker**

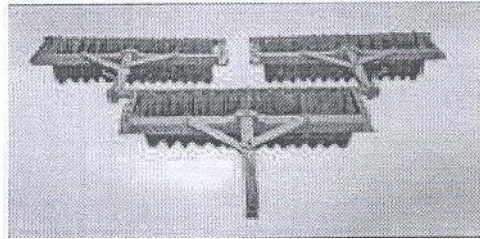

The implement consists of a number of cast iron V shaped rollers mounted on three axles. It can be operated either with one or three gangs. Sometimes it is attached behind the disk harrow (trailing type) to affect compaction for moisture conservation.

**Uses:**

- It is used for breaking of big clods of soils and packing of soil thereby conserving moisture.

**Vibratory Roller**

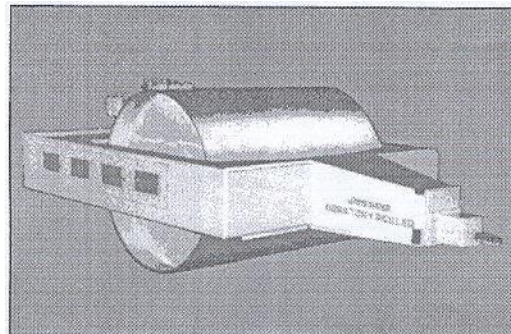

The vibratory roller carries the following essential components which includes a frame and carries the engine at the rear in static balance condition. The roller fabricated from steel plate with adjustable scraper fitted in the front and rear, vibratory drive having spring loaded centrifugal clutch directly to the mounted fly wheel, vibrating mechanism and towing mechanism. This machine is towed with the tractor for operation. The vibratory mechanism provided in the roller helps in achieving higher compactions.

**Uses:**

It is used for:

- Compacting embankments
- Sub grade sub bases for farms roads.
- Building foundations etc.

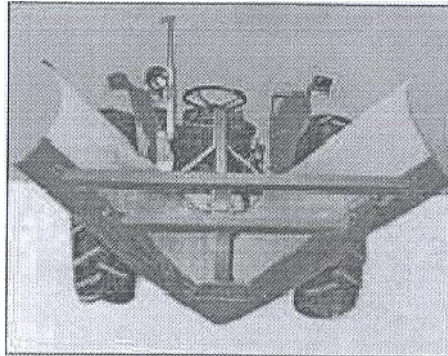
**Ditcher**

The major components are to curved wings with cutting blades, front cutting point, tie bars per adjusting wings pan and hitch assembly.

The operation consists of cutting the soil with cutting points of the blade and controlled hydraulically by the tractor. The ditcher penetrates in to the soil due to its own weight and suction of the cutting point. Upon drawing the ditcher in the field in open the soil in the shape of a ditch with V bottom or flat bottom. The depth and width of the ditch is adjusted from the operator seat. The cutting points and wings of the machine are replaceable.

**Uses:** For making ditches for irrigation and drainage.

## Rotary Ditcher

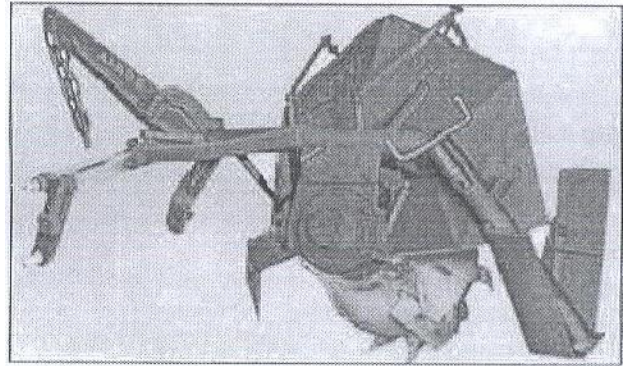
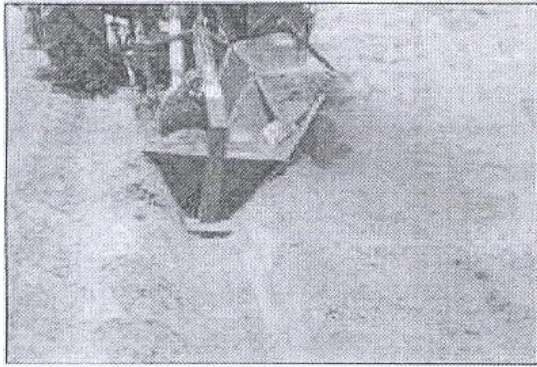

It is tractor operated machine and the major components are as follow:

- A rotary cutter operated by PTO shaft
- Gear box
- Three point linkage hitch system
- Body, deflector and ditch former

The field operation is carried out by the rotary cutters mainly and is consisted of a drum fitted with cutting knives or cutters. The knives may be of different shapes and are replaceable on wearing. The rotary cutter excavates the soil which is uniformly distributor to one side. The deflection of soil can be adjusted by the deflector. The ditch former fitted at the rear is of trapezoidal shape forms the ditch.

### Uses:

- Used for making ditches for irrigation and drainage purposes.

## LAND LEVELING

In the 3<sup>rd</sup> phase of land development process the land leveling is the subsequent operation which is carried out on the land. The land leveling is performed after the rough leveling off the field to level it in a precise manner to achieve the following objects:

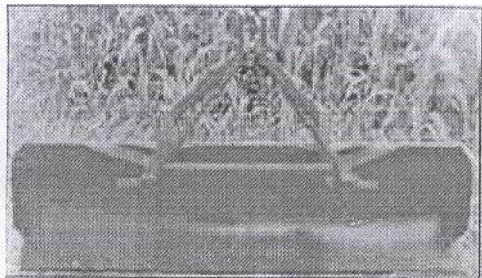

This job of precise leveling is may be aimed to develop the land for urban or rural uses for further activities of life. Here in this chapter we are to emphasize on the land leveling on the field for agricultural purposes. The land leveling objectives in this contest as are following:

1. To make the unutilized land useful for agricultural purposes.
2. To enhance the land value to earn maximum benefits.
3. To increase the total cultureable area of the land users.
4. To increase per capital income of the farmers.
5. To minimize irrigation water loses by leveled field.
6. To increase the irrigation efficiency at the farm level.
7. To increase the yield per hectare or per acres by uniform stand of the crops sown and finally maximizing the net return out of agricultural land.

To achieve the above benefits are objectives by correct leveling of lands, the farmer has to go under a prescribed procedure for the precise leveling of the land. For this purpose following two types of leveling equipments will be needed.

1. Farm equipments
2. Leveling equipments

The latest technological developments has provided the most cost effected leveling equipments known as laser leveler which are capable of carrying the leveling job in a precise miner by using the laser technology. To carry out the laser leveling operation effectively the topographic survey of the field is accomplish to locate the low and high spots of the field from which the average elevation of the field is calculated. The volume of soil to be shifted to the lowest spots will indicate the total earth work involved and accordingly type of the machine to be engaged is selected. Two types of equipments are essentially needed to initiate the work as previously indicated.

### **Tractor**

A four wheel tractor is required to drag the leveling bucket. The size of the tractor can vary from 30 hp to 500 hp depended upon the time restraints and field size. In Asia tractor arranging in size from 30 hp to 1000 hp have been successfully used with laser controlled systems. It is preferred to have four wheel drive tractor and the higher the horse power, the faster will be the operation. The power shift transmission in the tractor of prefer to manual shift transmission.

## **Plows**

It will be necessary to plow the field before and after the leveling. Depending upon the amount of soil that must be cut it may be useful to plow during the leveling operation. The plows like M.B. Plow disks or tine or usually used for this purposes.

## **Drag Bucket**

The leveling bucket may be tractor mounted or pulled by the tractor draw bar. Pull type systems are preferred because there are easier to handle. Bucket dimension and capacity will vary according to the available power source and field conditions. A 60 hp tractor will pull two meter wide and one meter deep bucket in most soil type.

## **Tractor Drawn Leveler**

It consists of a frame, three point linkage, scraping blades, thick curve sheet closed from sides to form a bucket. The blade is made of mild carbon steel or low alloy steel and tempered the blade is joined to the curved sheet with the fastener and replace able after becoming dull. The working depth is controlled by the hydraulic system of the tractor. This type of equipment is used for land preparation operation such as scraping, grading, leveling, back filling. Also for irrigation terraces work and general clearing of field.

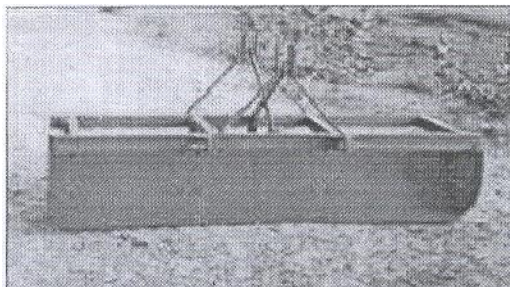

## **Laser Control equipment**

The laser control system requires a laser transmitter, a laser receiver, an electrical control panel and a twin solenoid hydraulic control valve.

The laser transmitter transmits a laser beam, which is intercepted by the laser receiver mounted on the leveling bucket. The control panel mounted on the tractor interprets the signal from the receiver and opens or closes the hydraulic control valve, which will raise or lower the bucket.

Some laser transmitters have the ability to operate over graded sloped ranging from 0.01% to 15% and apply dual controlled slope in the field.

## **Hydraulic Control System**

The hydraulic system of the tractor is used to supply oil to raise and lower the leveling bucket. The oil supplied by the tractors hydraulic pump is normally delivered at 2000-3000 psi pressure. As the hydraulic pump is a positive displacement pump and always pumping more oil than required, a pressure relief valve is needed in the system to return the excess oil to the tractor reservoir. If this relief valve is not large enough or malfunctions damage can be caused to the tractors hydraulic pump.

Wherever possible it is advisable to use the external remote hydraulic system of the tractor as this system has an inbuilt relief valve. Where the oil is delivered directly from the pump to the solenoid control valve, an in line relief valve must be fitted before the control valve. The solenoid control valve, when supplied by the laser manufacturers has an inbuilt relief valve.

The solenoid control valve controls the flow of oil to the hydraulic ram which raises and lowers the bucket. The hydraulic ram can be connected as a single or double acting ram. When connected as a single acting ram only one oil line is connected to the ram. An air breather is placed in the other connection of the ram to avoid dust contamination on the non working side of the ram. In this configuration the weight of the bucket is used for lowering.

The desired rate at which the bucket raises and lowers will depend on the operating speed. The faster the ground speed the faster the bucket will need to adjust. The rate at which the bucket will raise and lower is dependent on the amount of oil supplied to the deliver line. Where a remote relief valve is used before the control valve, the pressure setting on this valve will change the raise/lower speed. Laser manufacturer supplied control valves have pressure control adjustments on both the bypass relief valve and the raise and lower valves.

When using a hydraulic ram the ram should be positioned so that the ram body is connected so as to push from the bucket frame rather than the depth control wheels.

## **Tractor Hydraulic Control Valves**

Tractor hydraulic systems come as either open or closed centered systems. As the response time from each system is different the connections from the tractor to the control valve must be rearranged.

## **To determine the theoretical time to level a field**

The length of time taken to level the field can be calculated by knowing the average depth of cut from the cut/fill map, the dimensions of the field, the volume of soil that can be moved by the bucket and the tractor operating speed.

**Example 1**

Field dimensions = 100 m x 50 m

Average depth soil to be cut = 25 cm

Leveling bucket dimensions = 2 m x 1 m x 1 m

Bucket fill = 50%

Tractor speed (average of where the bucket is full and empty) = 8km/hr

Volume of soil to be moved = field area  $\times$  average depth cut (m)

$$= 100 \times 50 / 2 \times 0.25 = 325 \text{ m}^3$$

Volume soil in bucket (m<sup>3</sup>) = 2 x 1 x 1 x 0.5 = 1 m<sup>3</sup>

Number of trips required = 325/1 (full and empty) = 325 trips

Average trips length (50% of field) = 100/2m = 50m

Total distance traveled (m) = 325 x 50m = 16250 m

Time (hours) = distance (m)/speed (km/hr)/1000

$$= 16250/8/1000 = 2.03 \text{ hrs}$$

Therefore approximately 2 hours is required to level this field. This is a theoretical time and will vary according to the skill of the operator, the soil type and operating conditions.

**FARM TRACTOR***By**Engr. Prof. Dr. Muhammad Shafi Sabir, Subject Expert**Engr. Prof. Dr. Manzoor Ahmad. Subject Expert*

Tractor is a self-propelled power unit having wheels or tracks for operating agricultural implements and machines including trailers. Tractor engine is used as a prime mover for active tools and stationary farm machinery through power take-off shaft (PTO) or belt pulley.

**10.1 Classification of Tractors**

Tractors can be classified into three classes on the basis of structural-design:

(i) Wheel tractor: Tractors, having three or four pneumatic wheels are called wheel tractors. Four- wheel tractors are most popular everywhere.

**Figure 10.1 wheel tractors**

(ii) Crawler tractor: This is also called track type tractor or chain type tractor. In such tractors, there is endless chain or track in place of pneumatic wheels.

**Figure 10.2 Crawler tractors**

(iii) Walking tractor (Power tiller): Power tiller is a walking type tractor. This tractor is usually fitted with two wheels only. The direction of travel and its controls for field operation is performed by the operator, walking behind the tractor.



**Figure 10.3 Power tillers**

On the basis of purpose, wheeled tractor is classified into three groups:

**(a) General purpose tractor:** It is used for major farm operations; such as plowing, harrowing, sowing, harvesting and transporting work. Such tractors have (i) low ground clearance (ii) increased engine power (iii) good adhesion and (iv) wide tyres.



**Figure 10.4 General purpose tractors**

**(b) Row crop tractor:** It is used for crop cultivation. Such tractor is provided with replaceable driving wheels of different tread widths. It has high ground clearance to save damage of crops. Wide wheel track can be adjusted to suit inter row distance.



**Figure 10.5 Row crop tractors**

**(c) Special purpose tractor:** It is used for definite jobs like cotton fields, marshy land, hillsides, garden etc. Special designs are there for special purpose tractor.



Tractor with winch unit



Multi drive tractor



Tractor for golf grounds

**Figure 10.6 Special purpose tractor****10.2 Tractor Components**

A tractor is made of following main components:

(1) I. C. engine, (2) Clutch (3) Transmission gears (4) Differential unit (5) Final drive (6) Rear wheels (7) Front wheels (8) Steering mechanism (9) Hydraulic control and hitch system (10) Brakes (11) Power take-off unit (12) Tractor pulley and (13) Draw bar (14) Control panel.

**1. IC engine**

Internal combustion of suitable horse power is used as a prime mover in a tractor. Engines ranging from 8 to 200 hp are used in agricultural tractors. In India, four wheel tractors for agricultural operations are fitted with 25-80 hp. Walking type tractors are fitted with 8-12 hp engines

**2. Clutch**

Clutch is a device, used to connect and disconnect the tractor engine from the transmission gears and drive wheels. Clutch transmits power by means of friction between driving members and driven members

**Necessity of clutch in a tractor**

- a) Engine needs cranking by any suitable device. For easy cranking, the engine is disconnected from the rest of the transmission unit by the clutch. After starting the engine, the clutch is engaged to transmit the power from engine to gear box
- b) In order to change the gears, the gear box must be kept free from engine power, otherwise the gear teeth will be damaged and engagement of gears will be difficult. This work is done by clutch
- c) When the belt pulley of the tractor works in the field it needs to be stopped without stopping the engine. This is done by a clutch.

### 3. Power transmission system of a tractor

Transmission is a speed reducing mechanism, equipped with several gears. It may be called a sequence of gears and shafts, through which the engine power is transmitted to the tractor wheels. The system consists of various devices, which cause forward and backward movement of tractor to suit different field conditions. The complete path of power from engine to wheel is called power train

#### Functions of power transmission system

1. To transmit power from the engine to the rear wheels of the tractor
2. To make reduced speed available, to rear wheels of the tractor
3. To alter the ratio of wheel speed and engine speed in order to suit the field conditions
4. To transmit power through right angle drive, because the crankshaft and rear axle are normally at right angles to each other.

### 4. Transmission gears

A tractor runs at high speed, but the rear wheel of the tractor requires power at low speed and high torque. That's why it becomes essential to reduce the engine speed and increase the torque available at the rear wheel of the tractor because

$$Power, kW = \frac{2\pi NT}{60 \times 1000} \text{ --- 10.1}$$

Where,

T is torque in Newton –meter

N = speed in rev/min

If engine power is constant, it is obvious that for higher torque at wheels , low speed is required and vice versa.. So gear box is fitted between engine and rear wheels for variable speed and torque.

- a) **Differential unit** - Differential unit is a special arrangement of gears to permit one of the rear wheels of the tractor to rotate slower or faster than the other. While turning the tractor on a curved path, the inner wheel has to travel lesser distance than the outer wheel. The inner wheel requires lesser power than the outer wheel. This condition is fulfilled by differential unit, which permits one of the rear wheels of the tractor to move faster than the other at a turning point.

**Differential Lock** - Differential lock is a device to join both half axles of the tractor so

that even if one wheel is less resistance , the tractor comes out of the mud etc. as both wheels move with the same speed and apply equal traction.

#### b) **Final drive**

Final drive is a gear reduction unit in the power trains between differentials and drive wheels. Final drive transmits the power finally to the rear axle and the wheels. The tractor rear wheels are not directly attached to the half shafts but the drive is taken through a pair of spur gears. Each half shaft terminates in a small gear which meshes with a large gear called bull gear. The bull gear is mounted on a shaft, carrying the tractor rear wheel. The device for final speed reduction, suitable for tractor rear wheels is known as final drive mechanism.

### **5. Steering mechanism**

The system, governing the angular movement of front wheels of a tractor is called steering system. This system minimizes the efforts of the operator in turning the front wheels with the application of leverages. The different components of steering system are i)steering wheel ii) steering shaft iii)steering gear iv) drag link v)steering arm vi) tie rod viii) king pin When the operator turns the steering wheel, the motion is transmitted through the steering shaft to the angular motion of the pitman arm through a set of gears. The angular movement of the pitman arm is further transmitted to the steering arm through drag link and tie rods. Steering arm are keyed to the respective king pins which are integral part of the stub axle on which wheels are mounted. The movement of steering arm affects the movement of front wheel

### **6. Hydraulic control system**

It is a mechanism in a tractor to raise , hold or lower the mounted implement or semi-mounted equipments by hydraulic means. All tractors are equipped with hydraulic control system for operating three point hitch of the tractor. Hydraulic system works on PASCAL's Law which states that pressure applied to an enclosed fluid is transmitted equally in all directions.

#### **Basic components of hydraulic system**

1. Hydraulic pump,
2. Hydraulic cylinder and piston
3. Hydraulic tank
4. Control valve
5. Safety valve
6. Hose pipe and fittings
7. Lifting arms

The hydraulic pump draws up oil from the oil reservoir and sends it to the control valve under high pressure. From the control valve, the oil goes to the hydraulic cylinder to operate the piston, which in turn, raises the arms. The implements attached with the arms are lifted up.

### **7. Brakes**

Brake is used to stop or slow down the motion of the tractor. It is mounted on the driving axle and operated by two independent pedals. Each pedal can be operated independently to assist the turning of tractor during field work or locked together by means of a lock.

Types of brakes – a) Mechanical brake b) hydraulic brake

### **8. Power take off**

It is a part of tractor transmission system. It consists of a shaft, a shield and a cover. The shaft is externally splined to transmit torsional power to another machine. A rigid guard fitted on a tractor covers the power-take-off shaft as a safety device. The guard is called power take off shield. As per ASAE standards PTO speed is  $540 \pm 10$  rpm when operating under load. In order to operate 1000 rpm PTO drive machine, a new standard has been developed.



**PTO on a tractor**



**PTO drive**

**Figure 10.7 Tractor PTO**

### **9. Belt pulley**

All tractors are provided with a belt pulley. The function of the pulley is to transmit power from the tractor to stationary machinery by means of a belt. It is used to operate thresher, centrifugal pump, silage cutter, and several other machinery. The pulley is located either on the left, right or rear side of the tractor. Pulley drive is engaged or disengaged from the engine by means of a clutch.



**Figure 10.8 Belt pulley connected to tractor PTO**

#### 10. Control board or dash board

The control board of a tractor generally consists of

1. Main switch, 2. Throttle, 3. Decompression lever , 4. Hour meter, 5. Light switch`
6. Horn button, 7. Battery charging indicator, 8. oil pressure indicator, 10. Water temperature gauge.



**Figure 10.9 Tractor dash board**

#### 10.3 Control Board or Dash Board of a Tractor

The control board of a tractor generally consists of:

- (1) Main switch (2) Throttle lever (3) Decompression lever (4) Hour meter (5) Light switch (6) Horn button (7) Battery charging indicator (8) Oil pressure indicator and (9) Water temperature gauge.



**Figure 10.10 Tractor dash board**

## 10.4 Tractor tyres and front axle

**Tyres:** The tyres are available in many sizes with the ply ratings as 4, 6 or 8. The ply rating of tyres indicates the comparative strength of tyres. The higher the rating, the stronger are the tyres. The tyre size 12—38 means, that the sectional diameter of tyres is 12" and it is mounted on a rim of 38" diameter. The inflation pressure in the rear wheels of the tractor varies between 0.8 to 1.5 kg/cm<sup>2</sup>. The inflation pressure of the front wheel varies from 1.5 to 2.5 kg/cm<sup>2</sup>. Useful life of the pneumatic tyres under normal operating condition may be about 6000 working hours for drawbar work.

**Front Axle:** Front axle is the unit on which front wheel is mounted. This wheel is an idler wheel by which tractor is steered in various directions. The axle is a rigid tubular or I-section steel construction pivoted at the centre. There are various adjustments of front wheel.

### Hitching system of Tractor Drawn Implements

Tractor drawn implements possess higher working capacity and are operated at higher speeds. These implements need more technical knowledge for operations and maintenance work.

Tractor drawn implements may be a) Trailed type b) Semi-mounted type and c) Mounted type.

a) **Trailed type implement:** It is one that is pulled and guided from single hitch point but its weight is not supported by the tractor.

b) **Semi-mounted type implement:** This type of implement is one which is attached to the tractor along a hinge axis and not at a single hitch point. It is controlled directly by tractor steering unit but its weight is partly supported by the tractor.

1. Front wheel, 2. Fuel tank cap, 3. Accelerator pedal, 4. Brake pedal, 5. Steering wheel  
6. Hydraulic control lever, 7. Turn signal lamp, 8. Lift arm, 10. Rear tire, 10. Instrument panel  
11. Clutch pedal, 12. Step, 13. Seat, 14. Rear axle housing, 15. Side clearance, 16. Engine hood,  
17. Fan cover, 18. Muffler, 110. Fuel tank, 20. Throttle lever, 21. Main speed change lever, 22.  
Fender

c) **Mounted type implement:** A mounted implement is one which is attached to the tractor, such that it can be controlled directly by the tractor steering unit. The implement is carried fully by the tractor when out of work.

### Some Important Terms Connected with Tractors

**Wheelbase:** Wheel base is the horizontal distance between the front and rear wheels of a tractor, measured at the ground contact.

**Ground clearance:** It is the height of the lowest point of the tractor from the ground surface, the tractor being loaded to its maximum permissible weight.

**Track:** Track is the distance between the two wheels of the tractor on the same axle, measured at the point of ground contact.

**Turning space:** It is the diameter of the smallest circle, described by the outermost point of the tractor, while moving at a speed, not exceeding 2 km/hr with the steering wheels in full lock.

**Cage wheel:** It is a wheel or an attachment to a wheel with spaced cross bars for improving the traction of the tractor in a wet field. It is generally used in paddy fields.

### **Power Tiller**

It is a prime mover in which the direction of travel and its control for field operation is performed by the operator walking behind it. It is also known as hand tractor or walking type tractor. The concept of power tiller came in the world in the year 1920. Japan is the first country to use power tiller on large scale. In Japan, the first successful model of power tiller was designed in the year 1947. Production of power tiller rapidly increased during the year 1950 to 1965. Power tiller was first introduced in India in the year 1963. Power tiller is a walking type tractor. The operator walks behind the power tiller, holding the two handles of power tiller in his own hands. Power tiller may be called a single axle walking type tractor, though a riding seat is provided in certain designs. Average size of holding in India is about 2.5 hectares. There are 89% of total land holdings of less than six hectares. Under such conditions, power tiller may be useful as a power unit.

**Components of power tiller:** A power tiller consists of the following main parts:

(1) Engine (2) Transmission gears (3) Clutch (4) Brakes (5) Rotary unit.

All the power tillers are fitted with an I. C. engine. At present, most of the power tillers are fitted with diesel engine. The makes like Kubota, Mitsubishi, and Sachi have used diesel engine in India.

**Operation:** The main clutch is a lever on the handle. The lever can be shifted to on or off position while operating in the field. When the lever is shifted to on position, the power from the engine is transmitted through the main clutch to the various parts of the power tiller. When the lever is shifted to off position the power from the engine is cut-off from the rest of the transmission.

**Power transmission in power tiller:** For operation of power tiller, the power is obtained from the IC Engine, fitted on the power tiller. The engine power goes to the main clutch with the help

of belt or chain. From main clutch, the power is divided in two routes, one goes to transmission gears, steering clutch and then to the wheel. The other component goes to the tilling clutch and then to the tilling attachment. The flow diagram for transmission of power includes: Transmission gear, Steering clutch, Wheels, Engine Main clutch, Tilling clutch and Tilling attachment.

V-belt is usually used to transmit power from the engine to the main clutch, because V-belt has very high efficiency and it works as a shock absorber also.

**Main clutch:** Power goes from the engine to the main clutch. Clutch may be: (i) Friction clutch or (ii) V-belt tension clutch.

Friction clutch is generally used for bigger power tiller. Usually it is a dry type multiple disc clutch. V-belt tension clutch is used for small power tillers. The main functions of clutch in a power tiller are:

- (i) to transmit engine power to transmission gears and
- (ii) to make power transmission gradual and smooth.

**Transmission gears:** Transmission box consists of gears, shafts and bearings. The speed change device may be; (a) gear type or (b) belt type.

**Brakes:** All power tillers have some braking arrangement for stopping the movement. Most of the power tillers use inner side expansion type brake.

**Wheels:** Usually 2 to 4 ply pneumatic tyres are used in power tillers. The pressure of the tyre ranges from 1.1 to 1.4 kg/cm<sup>2</sup>.

**Rotary unit:** Power tiller has a rotary unit for field operation.

Rotary unit is of two types: (a) Centre drive type and (b) Side drive type.

**Centre drive** type has got transmission at the centre and the side drive type has transmission at one side. Centre drive type has the following characteristics: (a) Tilling width can be widened (b) Rotary unit is light in weight (c) Fixing of attachment is easy (d) The tine shaft can be detached easily (e) Mounting and dismounting of rotary unit is very easy (f) It may leave some portion of the field untilled (g) It has one point support on the ground.

In **side drive type** ;-(i) Deeper tilling is possible (ii) The arrangement is useful for hard soil (iii) It has two points support on the ground.

**Rotary tines:** Rotary tines are used in rotary unit for soil cutting and pulverization purpose.

Rotary tines are of three types:

- (i) Straight tines (ii) Curved tines and (iii) Sliding tines.

In case of **straight tines** : (a) Power consumption is less (b) Fine pulverization of soil is possible (c) Poor soil turning (d) Grass entangles in the tines very easily (e) It is suitable for hard soil.

In case of **curved tines**: (a) Good soil turning is possible (b) It is suitable for avoiding grasses (c) Pulverization of soil is coarse and (d) Power consumption is high.

**Sliding tines** have the characteristics of sliding on their positions according to the requirement.

**Steering clutch lever**: Steering clutch is provided on the grip of the right and left handles. When the left side is gripped, power is cut-off on left side of the wheel and the power tiller turns to the left. Similarly when the right side is gripped, the power tiller turns to the right.

## 10.5 Selection of Tractor

### A. Factors affecting the selection of tractor:

(1) **Land holding**: Under a single cropping pattern, it is normally recommended to consider 1 hp for every 1 hectares of land, In other words, one tractor of 20-25 hp is suitable for 20 hectares farm.

(2) **Cropping pattern**: Generally less than 1.0 ha/hp have been recommended where adequate irrigation facilities are available and more than one crop is taken. So a 30-35 hp tractor is suitable for 25 ha farm.

(3) **Soil condition**: A tractor with less wheel base, higher ground clearance and low overall weight may work successfully in lighter soil but it will not be able to give sufficient depth in black cotton soil.

(4) **Climatic condition**: For very hot zone and desert area, air cooled engines are preferred over water-cooled engines. Similarly for higher altitude, air cooled engines are preferred because water is liable to be frozen at higher altitude.

(5) **Repairing facilities**: It should be ensured that the tractor to be purchased has a dealer at nearby place with all the technical skills for repair and maintenance of machine.

(6) **Running cost**: Tractors with less specific fuel consumption should be preferred over others so that running cost may be less.

(7) **Initial cost and resale value**: While keeping the resale value in mind, the initial cost should not be very high; otherwise higher amount of interest will have to be paid.

(8) **Test report**: Test report of tractors released from farm machinery testing stations should be consulted for guidance.

**B. SAE recommendations for tractor selection:** Selection of tractor depends on the size of farm. Medium size farms may need only one tractor to do all jobs on the farm like plowing, cultivations, sowing, row-crop work, harvesting, transport and stationary PTO work. Whereas, large farms require a range of makes or sizes to suit the various jobs. Tractor sizes classification for 3-point linkage categories as recommended by Society of Automotive Engineers (SAE) is given below.

Category	Maximum Drawbar Power Range (kW)
1	15-35
2	30-75
3	60-168
4	135-300

Category 2 is most widely used, but category 1 is employed for a range of implement designed for use with small to medium tractors. On large farms, more than one type and size of tractor are selected in order to match the tractor with job in hand and permits choosing the best equipment from more than one manufacturer. It necessitates that more spare parts on the farm be kept if more than one type of tractors are operated and man responsible for maintenance should be well versant with the job.

The power needed for plowing and other cultivations varies greatly according to the nature and condition of the land. The drawbar pull needed may be calculated by multiplying plowing resistance of soil with total cross sectional area of the furrow slices. The plowing resistance values of various types of soils are listed as below.

Soil Type	Plowing Resistance (kN/m <sup>2</sup> )
Very light blowing sand	34.5
Heavy clay	103.4
Medium loam	68.95

Thus in average conditions, the drawbar pull needed to operate a three-furrow plough with furrows 10 in ( 254 mm) wide and 6 in ( 152.4 mm ) deep would be:

$$10 \times 6 \times 3 \times 10 = 1800 \text{ lbf}$$

$$(0.254 \times 0.1524 \times 3 \times 68.95 = 8.00 \text{ kN})$$

### 10.6 Tractor Power

Tractor power is received in several ways. Traction of drive wheels is used for pulled or towed implements whereas pull or draft is obtained from the drawbar. Rotary power is obtained from

the power take –off (PTO) shaft or from a belt pulley. Both linear and rotary power can be produced by a tractor’s hydraulic system.

Drawbar power can be calculated by the following formula.

$$DBP = \frac{F \cdot S}{c}$$

Where DBP = drawbar power expressed in kw [ HP]

F = force measured in kN [lb]

S = forward speed, km/hr [MPH]

C = constant, 3.6 [375]

PTO power is calculated as follows;

$$PTOP = \frac{2FRN}{c} = \frac{2TN}{c}$$

where PTO = PTO power expressed in kW [HP]

F = tangential force, kN [lb]

N = revolutions per minute (rpm)

T = torque, kN.m [lb.ft]

c = constant, 60 [33000]

Hydraulic power can be worked out by using following formula.

$$HyP = \frac{P \cdot Q}{c}$$

where HyP = hydraulic power, kw [HP]

P = gage pressure, kPa, [psi]

Q = flow rate, L/s [gal/min]

C = constant, 1000 [1714]

**Rolling Resistance** Rolling resistance concept is needed for operation of equipment over farm ground. Rolling resistance can be defined as the force required to keep the equipment moving at a constant speed and is proportional to weight of equipment. This force is needed to provide the energy required to deflect rubber tyres, to compress or push aside soft soil, and to overcome wheel and axle bearing friction. The term coefficient of rolling resistance is defined as ratio of horizontal force (draft) to the vertical force on wheel axle. Thus the rolling resistance is reduced when the weight on the wheel is reduced.

**Example 1.** A 4-furrow plough with furrows 15 in ( 381 mm ) wide and 6 in ( 152 mm ) deep is operated in a medium loam soil at a plowing speed of 5 m.p.h. (8.05 km ). Calculate the drawbar power required for operation of this plough.

$$\text{Drawbar pull} = 15 \times 6 \times 4 \times 10 = 3600 \text{ lbf}$$

$$[ 0.381 \times 0.152 \times 4 \times 68.95 = 15.97 \text{ kN} ]$$

$$\text{DBP} = \frac{F.S}{c}$$

$$\text{DBP} = \frac{\text{speed (m. p. h.)} \times \text{drawbar pull (lbf)}}{375} = \frac{5 \times 3600}{375} = 48 \text{ hp}$$

In SI units, power = Nm/s, watts

$$\text{DBP} = \frac{F.S}{c} = \frac{15.97 \times 8.05}{3.6} = 35.71 \text{ kW}$$

**Example 2.** A tractor is pulling 10000 kg [22000 lb] sugar cane trolley at 8.05 km/hour [5.00 MPH]. The tractor mass is 8000 kg [17600 lb].

Find DBP a) when the tractor is moving on the level road b) When moving up fly over bridge. Assume the coefficient of rolling resistance is 0.6 for all wheels.

#### For level road

$$\text{Weight of tractor} = 8000 \times 10.81 = 78.480 \text{ kN [17600 lb]}$$

$$\text{Weight of trolley} = 10000 \times 10.81 = 98.100 \text{ kN [22000 lb]}$$

#### Coefficient of rolling resistance =

Horizontal force (draft) required to pull a loaded wheel over a horizontal surface

vertical force on that wheel axle

$$\text{Horizontal force (draft)} =$$

vertical force on wheel x coefficient of rolling Resistance

$$\text{Drawbar pull (Draft)} = 98.100 \times 0.06 = 5.886 \text{ kN [22000} \times 0.06 = 1320 \text{ lb]}$$

$$\text{DBP} = \frac{5.886 \times 8.05}{3.6} = 13.16 \text{ kW} = 17.6 \text{ hp}$$

For moving up fly over bridge

$$\Theta = \tan^{-1} (1/15) = 0,0667 \text{ rad} = 0.0667 \times 57.272 = 3.820$$

Components of weight of trolley

$$\text{Perpendicular to the slope} = 10000 \times 10.81 \times \cos 0.0667$$

$$97882 \text{ N} = 97.882 \text{ kN}$$

$$[22000 \times \cos 3.82 = 21951 \text{ lb}]$$

$$\begin{aligned}
 \text{Parallel to slope} &= 10000 \times 10.81 \times \sin 0.0667 \\
 &6535 \text{ N} = 6.535 \text{ kN} \\
 &[ 22000 \times \sin 3.82 = 1465.7 \text{ lb} ] \\
 \text{Rolling resistance} &= 0.06 \times 97,882 = 5.873 \text{ kN} \\
 &[ 0.06 \times 21951 = 1317 \text{ lb} ] \\
 \text{Drawbar pull} &= 6.535 + 5.873 = 12.408 \text{ kN} \\
 &[ 1465.7 + 1317 = 2782.7 \text{ kN} ] \\
 \text{Drawbar power (DBP)} &= 12.408 \times 8.05/3.6 = 27.75 \text{ kW} \\
 &[ 2782.7 \times 5.00/375 = 37.10 \text{ hp} ]
 \end{aligned}$$

**Example 3.** Calculate the extra power required to move the tractor only up the fly over bridge as compared to flat ground. Use the data given in example 2.

**For level ground**

$$\begin{aligned}
 \text{(a) Rolling resistance:} & 0.06 \times 8000 \times 10.81 = 4708.8 \text{ N} = 4.709 \text{ kN} \\
 & [ 0.06 \times 17600 = 1056 \text{ lb} ] \\
 \text{(b) Power:} & 4.709 \times 8.05/3.6 = 10.530 \text{ kW} \\
 & [ 1056 \times 5.00/375 = 14.08 \text{ hp} ]
 \end{aligned}$$

**For slope**

Weight components of tractor

$$\begin{aligned}
 \text{Perpendicular to the slope} &= 8000 \times 10.81 \cos 0.0667 = 78.305 \text{ kN} \\
 & [ 17600 \times \cos 3.82 = 17560.9 \text{ lb} ] \\
 \text{Parallel to slope} &= 8000 \times 10.81 \times \sin 0.0667 = 5.228 \text{ kN} \\
 & [ 17600 \times \sin 3.82 = 1172.5 \text{ lb} ] \\
 \text{Rolling resistance} &= 0.06 \times 78.305 = 4.698 \text{ kN} \\
 & [ 0.06 \times 17560.9 = 1053.65 \text{ lb} ] \\
 \text{Power, DBP} &= (5.228 + 4.698) \times 8.05/3.6 = 22.196 \text{ kW} \\
 & [ (1172.5 + 1053.65) \times 5.00/375 = 210.68 \text{ hp} ] \\
 \text{Increase in power} &= 22.196 - 10.530 = 11.666 \text{ kW} \\
 & [ 210.68 - 14.08 = 15.6 \text{ hp} ]
 \end{aligned}$$

**10.7 Farm Tractor Size Determination**

The purchase of a tractor and associated equipment is a substantial investment. The result of improper size can be costly - a tractor too small can result in long hours in the field, excessive

delays and premature replacement.

A tractor too large can result in excessive operating and overhead costs. It is important to know how to determine the size and number of tractors needed for a farm operation. The ideal equipment should get the work completed on time at the lowest possible cost. The size of the largest tractor should be based on getting critical, high-horsepower jobs done within a specified time period.

### **Determining Minimum Horsepower Requirements**

A suggested procedure for determining the minimum horsepower needed is:

1. Determine the most critical field operation requiring implements with a high draft.
2. From past experiences, estimate how many days are available to complete this critical field operation. If you plan to run a double shift be realistic about maintenance of the machine and the operator's personal time.
3. Calculate the capacity needed in acres per hour in order to get the job done within the time allotted.
4. Determine the size of implement needed.
5. Select a tractor of proper size to pull the implement. To do this:
  - 1) Determine draft of implement (Table 2)
  - 2) Determine drawbar horsepower needed to pull implement
  - 3) Determine PTO horsepower needed.

Obviously the most important decision is to determine the size of the largest tractor. Normally the size of the largest tractor should be based on getting the critical, high-horsepower jobs done within a specified time period. It follows, then, that as much use as possible should be made of the same tractor for other operations.

**Example 4.** A small farm with 60 acres of sandy soil planted in row crops. During the spring five weeks of calendar time is available to twice disk the land with a tandem disk harrow prior to planting. The owner has 5 days (Saturday's) available to prepare the land. Number of productive hours per work day is assumed to 8. How large should the tractor and harrow be in order to complete the soil preparation during this five week period? Determining Tractor Size

#### **Solution:**

Step 1. Determine the critical high draft tillage operation. In this example disking prior to planting is that operation.

Step 2. Determine available time. There are 35 days of calendar time allotted to this job.

During this time span, 5 days (40 hours) are estimated to be available for field work.

Step 3. Determine Field Capacity Needed (Acres per Hour).

$$FC = \frac{\text{Total acres to cover}}{\text{Number of work days} \times \text{avg hrs per day}}$$

$$FC = \frac{60 \text{ acres} \times \text{disk twice}}{5 \text{ days} \times 8 \text{ hrs per day}} = 3 \text{ acres per hr}$$

In order to disk 3.0 acres per hour at a speed of 5 mph, a disk of the following minimum width is needed:

$$W = \frac{10^* \times FC}{\text{speed}} = \frac{10 \times 3 \text{ acres per hr}}{5 \text{ mph}} = 6 \text{ ft}$$

A 6 foot disk would be bought to provide a margin for field capacity.

\* The Factor 10, is used to reflect theoretical capacity (1/8.25) of an implement 1-ft wide, 1 mph, and to reflect 18 % field loss for overlap, turning loss, and other inefficiencies of field work.

Step 5. Tractor Selection

1. Draft (Soil Resistance) = Width of Implement x Draft per Foot per Depth of Operation in Inches.

The draft of a tandem disk harrow in sandy soil is 92 pounds per foot width per depth of operation in inches (Table 2).

The total load that a 6 feet disk operating 8 inches deep requires of the tractor is:

= 6 ft. x 92 lbs. draft per foot per inch (from Table 1) x 4 inches deep = 2,208 pounds total draft

2. Drawbar Horsepower Required (DBP)

$$DBP = \frac{\text{Total draft (lbs)} \times \text{speed (mile per hr)}}{375} = \frac{2208 \times 5}{375} = 29.4$$

3. Determine Minimum PTO Horsepower:

Table 1. PTO horsepower multiplication factors for different soil conditions

Soil Condition	Multiply Drawbar HP by
Firm untilled soil	1.5
Previously tilled soil	1.8
Soft or sandy soil	2.1

**29.4 HP (Drawbar) x 2.1 = 61.8 ESTIMATED PTO HP REQUIRED**

### Speed and Tractor Size

Speed is a major factor affecting horsepower requirements. Higher working speeds result in more horsepower needed to perform the job. In the example a working speed of 5 mph was used. Should the speed be reduced to 3.5 mph, the power requirements would be:

$$DBP = \frac{\text{Total draft (lbs)} \times \text{speed (mile per hr)}}{375} = \frac{2208 \times 3.5}{375} = 20.6$$

PTO Horsepower Required (3.5 mph, Sandy Soil)

$$= 20.6 \text{ hp (Drawbar X 2.1)} = 43.3 \text{ hp (PTO)}$$

This is a reduction of 18.5 horsepower (PTO) required to pull a 6 ft. wide tandem disk harrow. Obviously the performance rate (acres per hour) will be reduced by traveling at a lower speed. In instances where timeliness is not a necessity, a small tractor can be used to perform the job provided adequate drawbar pull is available.

**Table 2. Draft and power requirements for tillage and seeding implements.**

Implement	unit	Speed (mph)	Draft (pound force/unit (ack depth) Clay Soil	Draft (pound force/unit (inch depth) Loamy Soil	Draft (pound force/unit (inch depth) Sandy Soil
<b>MAJOR TILLAGE TOOLS</b>					
<b>Subsoiler/Manure Injector</b>					
12 inch winged point	tools	5	295	208	133
12 inch winged point	tools	5	382	287	172
Moldboard Plow	ft	4.5	223	158	101
<b>Chisel Plow</b>					
2 inch straight point	tools	5	115	98	75
3 inch shovel/4 inch sweep	tools	5.5	139	118	91
4 inch twisted shovel	tools	5.5	160	136	104
<b>8sweep Plow</b>					
primary tillage	ft	5	138	118	89
secondary tillage	ft	5	90	76	58
<b>Disk Harrow, Tandem</b>					
primary tillage	ft	5.5	117	103	82
secondary tillage	ft	5.5	71	62	55
<b>Disk Harrow, Offset</b>					
primary tillage	ft	5	134	117	104
secondary tillage	ft	5	82	72	64
<b>Disk Gang, Single</b>					
primary tillage	ft	5.5	39	34	30
secondary tillage	ft	5.5	27	23	21
<b>Coulters</b>					
smooth orifice	tools	5	54	48	42
beveled or flute	tools	5	65	57	51
<b>Field Cultivator</b>					
primary tillage	tools	5	50	43	33
secondary tillage	tools	5	35	30	23
<b>Row Crop Cultivator</b>					
S-tine	rows	5	129	109	84
C-shank	rows	5	239	203	155
No-till	rows	5	417	354	271
Rod Weeder	ft	4.5	63	54	41
Disk-Beeder	rows	5	209	180	163
<b>MINOR TILLAGE TOOLS</b>					
Rotary Hoe	ft	7	53	53	53
Coll Tine Harrow	ft	5	20	20	20
Spoke Tooth Harrow	ft	5	52	52	52
Spring Tooth Harrow	ft	5	182	182	182
Roller Packer	ft	5	60	60	60
Roller Harrow	ft	5	270	270	270
Land Plane	ft	5	798	798	798

**Table 3. Rotary power requirements for implements based on material input.**

Implement	HP (PTO) /Feed Rate Wet Basis (ton/hr)
Baler, small rectangular	3.9
Baler, large round (var. chamber)	6.7
Baler, large round (fix. chamber)	5.6
Combine, small grains	31.2
Combine, corn	48.9

Feed mixer	2.8
Forage blower	1.1
Flail harvester, direct-cut	14.7
Forage harvester, corn silage	12.0
Forage harvester, wilted alfalfa	12.9
Forage harvester, direct-cut	14.9
Forage wagon	0.3
Grinder mixer	4.9
Manure spreader	0.3
Tub grinder, straw	16.9
Tub grinder, alfalfa hay	11.3

**Table 4. Rotary power required for various implements based on width.**

<b>Implement</b>	<b>Horse Power (PTO) /width (ft)</b>
Cotton picker	3.8
Cotton stripper	0.8
Mower, cutterbar	0.5
Mower, disk	2.0
Mower, flail	4.1
Mower-conditioner, cutterbar	1.8
Mower-conditioner, disk	3.3
Mower, rotary horizontal	10.4
Rake, side delivery	0.2
Rake, rotary	0.8
Tedder	0.6
Windrower/swather, small grain	0.5

### Problems

1. Calculate the drawbar power to operate three-furrow plough with furrows 12 in (305 mm ) wide and 8 in ( 203 mm ) deep in a heavy clay soil. The speed of plowing is 4 M.P.H.
2. A tractor is pulling a load of 10 kN [2248 lb] at 10 km/hr [6.21 M.P.H.]. Calculate the drawbar power of the tractor.
3. What power is needed to lift a car by a car lifter to a height of 152.4 cm [60 in ] in 5 sec. The mass of the car is 350 kg [ 770 lb ].
4. Calculate the power requirement if the power steering system of a tractor requires 1.50 L/s flow of a hydraulic fluid at a pressure of 14500 kPa [ 2102.5 psi ] for making a sharp turn.

## CHAPTER-11

### ESTIMATING FARM POWER & MACHINERY COSTS

By

*Engr. Prof. Dr. Manzoor Ahmad, Subject Expert*

*Engr. Dr. Kh. Altaf Hussain, Subject Expert*

Farm power, machinery and equipment are major cost items in agriculture. Larger machines, new technology, higher prices for parts and new machinery, and higher energy prices have caused machinery and power costs to rise in recent years. However, good managers can control machinery and power costs per hectare. Making smart decisions about how to acquire machinery, when to trade, and how much capacity to invest in can reduce machinery costs by as much as Rs 10000 per hectare. All of these decisions require accurate estimates of the costs of owning and operating farm machinery.

#### 11.1 Machinery Costs

Farm machinery costs can be divided into two categories: (i) annual ownership costs i.e. Fixed cost, which occur regardless of machine use, and (ii) operating costs, which vary directly with the amount of machine use. The true value of some of these costs is not known until the machine is sold or worn out. But the costs can be estimated by making a few assumptions about machine life, annual use, and fuel and labor prices.

##### **Fixed costs**

Include depreciation, interest (opportunity cost), taxes, insurance, and housing facilities.

**Depreciation** - Depreciation is a cost resulting from wear, obsolescence, and age of a machine. The degree of mechanical wear may cause the value of a particular machine to be somewhat above or below the average value for similar machines when it is traded or sold. The introduction of new technology or a major design change may make an older machine suddenly obsolete, causing a sharp decline in its remaining value. But age and accumulated hours of use usually are the most important factors in determining the remaining value of a machine. Before an estimate of annual depreciation can be calculated, an economic life for the machine and a salvage value at the end of the economic life must be specified. The economic life of a machine is the number of years for which costs are to be estimated. It often is less than the machine's service life because most farmers trade a machine for a different one before it is completely worn out. A good rule of thumb is to use an economic life (Age) of 10 to 12 years for most new

farm machines and a 15-year life for tractors, unless it is known that the machine will be traded sooner. Salvage value (SV) is 10 % purchase price (PP) of the machine.

**Interest** - If the operator borrows money to buy a machine, the lender will determine the interest rate to charge. But if the farmer uses his or her own capital, the rate will depend on the opportunity cost for that capital elsewhere in the farm business. If only part of the money is borrowed, an average of the two rates should be used. For the example assume an average interest rate (i) of 8-10 percent.

**Taxes and Insurance** - This cost usually is much smaller than depreciation and interest, but they need to be considered. A cost estimate equal to 1.0 percent of the purchase price often is used.

**Housing** - Providing shelter, tools, and maintenance equipment for machinery will result in fewer repairs in the field and less deterioration of mechanical parts and appearance from weathering. That should produce greater reliability in the field and a higher trade-in value. An estimated charge of 1.0 percent of the purchase price is suggested for housing costs.

**Total Fixed Cost** - The estimated costs of depreciation, interest, taxes, insurance, and housing are added together to find the total ownership cost. If the tractor/Machinery is used 500 hours per year, the total ownership cost per hour is: Ownership cost/use hours per year

### **Operating costs**

Also called variable costs, include repairs and maintenance, fuel, lubrication, and operator labor.

**Repairs and Maintenance** - Repair costs occur because of routine maintenance, wear and tear, and accidents. Repair costs for a particular type of machine vary widely from one geographic region to another because of soil type, rocks, terrain, climate, and other conditions. Within a local area, repair costs vary from farm to farm because of different management policies and operator skill. The best data for estimating repair costs are the operator's own records of past repair expenses. Good records indicate whether a machine has had above or below average repair costs and when major overhauls may be needed. They also will provide information about the operator's maintenance program and mechanical ability. Without such data, repair costs must be estimated 5-8 percent of purchase price of tractor/power tiller per year.

**Fuel** - Fuel costs can be estimated by using average fuel consumption for field operations in liters per hour. Those figures can be multiplied by the fuel cost per liter to calculate

the average fuel cost per hour/hectare.

**Lubrication** - Surveys indicate that total lubrication costs on most farms average about 15 percent of fuel costs. Therefore, once the fuel cost per hour has been estimated, it can be multiplied by 0.15 to estimate total lubrication costs.

**Labor** - Because different size machines require different quantities of labor to accomplish such tasks as planting or harvesting, it is important to consider labor costs in machinery analysis. Labor cost also is an important consideration in comparing ownership to custom hiring. Actual hours of labor usually exceed field machine time by 10 to 20 percent, because of travel time and the time required lubricating and servicing machines. Consequently, labor costs can be estimated by multiplying the labor wage rate times 1.1 or 1.2. Using a labor value of Rs 50 per hour for our tractor, different wage rates can be used for operations requiring different levels of operator skill.

### **Total Operating Cost**

Repair, fuel, lubrication, and labor costs are added to calculate total operating cost.

### **Total Cost**

After all costs have been estimated, the total ownership cost per hour can be added to the operating cost per hour to calculate total cost per hour to own and operate the machine.

### **Implement Costs**

Costs for implements or attachments that depend on tractor power are estimated in the same way as for the example tractor, except that there are no fuel, lubrication, or labor costs involved.

### **Composition of Costs**

An example problem will be used to illustrate the calculations. The example uses a 15 hp diesel power tiller with a list price of Rs 150,000. An economic life of 10 years is assumed, and the tiller is expected to be used 500 hours per year.

### **Assumptions**

- Salvage value (SV): 10%
- Interest rate: 10 %
- Insurance & taxes: 1% of PP

- Housing: 1 % of PP
- Fuel consumption: 1-lit/h
- Fuel Cost = Rs 50 per lit
- Lubrication cost: Rs150 per lit
- Lubrication consumption: 5% of fuel
- Repair and Maintenance: 5-8 %
- Labor: Rs 50 per hour

**Solution:** The total cost can be calculated as:

### 1. Fixed Cost:

- a. = Rs13500 per year
- b. = Rs 8250 per year
- c. Insurance & Taxes = 1% of PP =  $0.01 \times 150000 = \text{Rs } 1500$  per year
- d. Housing = 1 % of PP =  $0.01 \times 150000 = \text{Rs } 1500$  per year

**Total fixed cost** = Rs 24750 per year

**Total fixed cost per hour** =  $24750/500 = \text{Rs } 411.5$

### 2. Operating Cost

- a. Repair & Maintenance = 5% of PP =  $0.05 \times 150000 = \text{Rs } 7500$  per year  
Per hour cost =  $7500/500 = \text{Rs } 15.0$
- b. Fuel =  $1 \times 50 = \text{Rs } 50/\text{h}$
- c. Lubrication =  $1 \times 0.05 \times 150 = \text{Rs } 7.5/\text{h}$
- d. Labor cost = Rs 50/h

**Total operating cost** = Rs 122.50

**Total cost** =  $411.5 + 122.5 = 172.0$

How much hours the machinery is to be used annually, which has to be calculated as follows:

BEP = Rs 811.18 h/year

### • Economics of farm Equipment

Annual use of Power tiller: > 600 hours

Profit to Entrepreneur/farmer

Annual Expenditure:  $172 \times 600 = 1,03,200$

Annual Income:  $400 \times 600 = 2,40,000$

**Net annual income, Rs = 1,36,800**

## TILLAGE AND ITS IMPLEMENTS

By

*Engr. Prof. Dr. Muhammad Iqbal, Subject Expert*

*Engr. Prof. Dr. Manzoor Ahmadl, Subject Expert*

### 12.1 Tillage

It is a mechanical manipulation of soil to provide favourable condition for crop production. Soil tillage consists of breaking the compact surface of earth to a certain depth and to loosen the soil mass, so as to enable the roots of the crops to penetrate and spread into the soil.

### 12.2 Objectives of Tillage

1. To obtain deep seed bed, suitable for different type of crops.
2. To add more humus and fertility to soil by covering the vegetation.
3. To destroy and prevent weeds.
4. To aerate the soil for proper growth of crops.
5. To increase water-absorbing capacity of the soil.
6. To destroy the insects, pests and their breeding places and
7. To reduce the soil erosion.

### 12.3 Classification of Tillage

1. **Primary tillage** - It constitutes the initial major soil working operation. It is normally designed to reduce soil strength, cover plant materials and rearrange aggregates. The operations performed to open up any cultivable land with a view to prepare a seed bed for growing crops is known as primary tillage. Animal drawn implements mostly include indigenous plough and mould-board plough. Tractor drawn implements include mould-board plough, disc plough, subsoil plough, chisel plough and other similar implements.
2. **Secondary tillage** - Tillage operations following primary tillage those are performed to create proper soil tilth for seeding and planting are secondary tillage. These are lighter and finer operations, performed on the soil after primary tillage operations. Secondary tillage consists of conditioning the soil to meet the different tillage objectives of the farm. The implements include different types of harrow, cultivators, levelers, clod crushers etc.

## 12.4 Types of Tillage

1. **Minimum Tillage** - It is the minimum soil manipulation necessary to meet tillage requirements for crop production.



**Figure 12.1 Minimum Tillage for Wheat**

2. **Strip Tillage** - It is a tillage system in which only isolated bands of soil are tilled.



**Strip tillage in wheat**

**Strip tillage in corn**

**Strip till in wheat**

**Figure 12.2 Strip tillage**

3. **Rotary Tillage** -It is the tillage operations employing rotary action to cut, break and mix the soil.
4. **Mulch Tillage** -It is the preparations of soil in such a way that plant residues or other mulching materials are specially left on or near the surface.



**Figure 12.3 Farm Waste Mulching**

5. **Combined Tillage** -Operations simultaneously utilizing two or more different types of tillage tools or implements to simplify, control or reduce the number of operations over a field are called combined tillage.

#### 12.5 Difference between tools/Implements/Machines

1. **Tool** - It is an individual working element such as disc or shovel.
2. **Implement** - It is equipment generally having no driven moving parts, such as harrow or having only simple mechanism such as plough.
3. **Machine** -It is a combination of rigid or resistant bodies having definite motions and capable of performing useful work.

#### 12.6 Implements for Primary Tillage

**Plough** - Plowing is the primary tillage operations, which are performed to cut, break and invert the soil partially or completely. Plowing means opening the upper crust of the soil, breaking the clods and making the soil suitable for sowing seeds.

##### **Indigenous plough**

It penetrates into the soil and breaks it open. The functional components include share, body, shoe, handle and beam. It can be used for dry land, garden land and wetland plowing operations.

Parts are detailed as below:

1. **Share** - It is the working part of the plough attached to the shoe with which it penetrates into the soil and breaks it open.
2. **Shoe** - It supports and stabilizes the plough at the required depth.
3. **Body** - It is main part of the plough to which the shoe, beam and handle are generally attached. In country plough body and shoe are integral part.

4. **Beam** - It is generally a long wooden piece, which connects the main body of the plough to the yoke.
5. **Handle** - A wooden piece vertically attached to the body to enable the operator to control the plough.

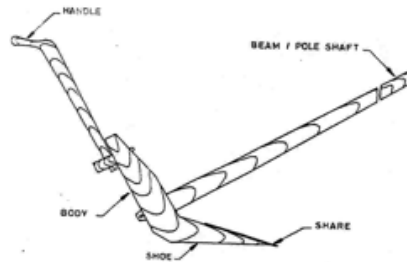

Figure 12.4 Indigenous plow

### Operational adjustments

- a. Lowering or raising the beam with respect to the plough body, resulting in a change in the angle of the share with the horizontal plane to increase or decrease the depth of operation.
- b. Changing the length of the beam (body to yoke on the beam) to increase or decrease the depth of operation.
- c. The size of the plough is represented by the width of the body.

### Mould board plough

**Function:** 1) cutting the furrow slice 2) lifting the soil 3) turning the furrow slice and 4) pulverizing the soil.

### Components of Mould board plough

M.B. plough consists of Share, Mould board, Land side, Frog and Tail piece.



Figure 12. 5 M.B. Plow

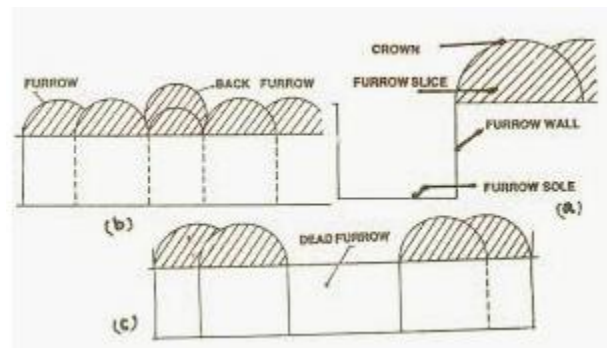

Figure 12. 6 Furrow types

**A. Share** - It penetrates into the soil and makes a horizontal cut below the soil surface. It is a sharp, well polished and pointed component. The shares are made of chilled cast iron or steel. The steel mainly contains about 0.70 to 0.80% carbon and about 0.50 to 0.80% manganese besides other minor elements.

**B. Moldboard** - The Moldboard is that part of the plough which receives the furrow slice from the share. It lifts, turns and breaks the furrow slice. To suit different soil conditions and crop requirements, Moldboard has been designed in different shapes. The Moldboard is of following types: a) General purpose b) Stubble c) Sod or Breaker and d) Slat.

**i) General purpose** - It is a Moldboard having medium curvature lying between stubble and sod. The sloping of the surface is gradual. It turns the well defined furrow slice and pulverizes the soil thoroughly. It has a fairly long Moldboard with a gradual twist, the surface being slightly convex.

**ii) Stubble type** - It is short but broader Moldboard with a relatively abrupt curvature which lifts breaks and turns the furrow slice used in stubble soils. Its curvature is not gradual but it is abrupt along the top edge. This causes the furrow slice to be thrown off quickly, pulverizing it much better than other types of Moldboard. This is best suited to work in stubble soil that is under cultivation for years together. Stubble soil is that soil in which stubble of the plants from the previous crop is still left on the land at the time of plowing.

**iii) Sod or Breaker type** - It is a long Moldboard with gentle curvature which lifts and inverts the unbroken furrow slice. It is used in tough soil of grasses. It turns over thickly covered soil. This is very useful where complete inversion of soil is required by the farmer.

**iv) Slat type** - It is a Moldboard whose surface is made of slats placed along the length of the Moldboard, so that there are gaps between the slats. This type of Moldboard is often used, where the soil is sticky, because the solid Moldboard does not scour well in sticky soils.

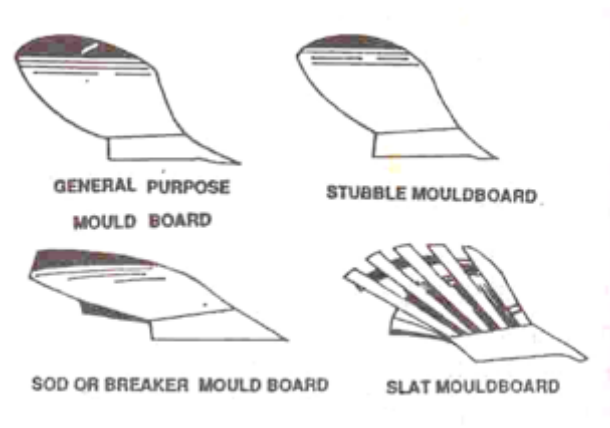
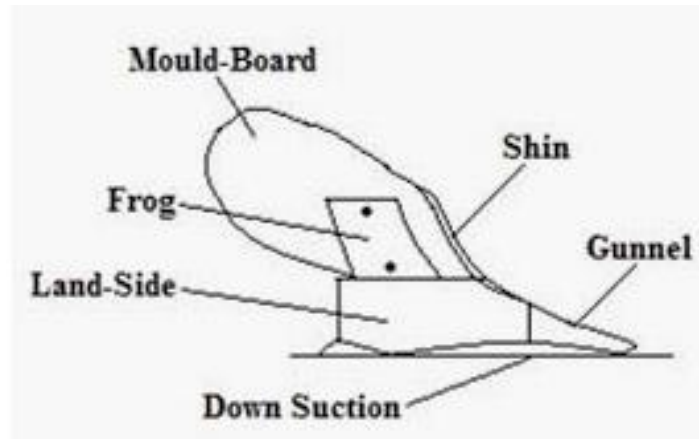

**Figure 12.7 Types of M,B, Plow**

**C) Land side** - It is the flat plate which bears against and transmits lateral thrust of the plough bottom to the furrow wall. It helps to resist the side pressure exerted by the furrow slice on the Moldboard. It also helps in stabilizing the plough while it is in operations.

**D) Frog** -Frog is that part of the plough bottom to which the other components of the plough bottom are attached. It is an irregular piece of metal. It may be made of cast iron for cast iron ploughs or it may be welded steel for steel ploughs.

**E) Tail piece** - It is an important extension of Moldboard which helps in turning a furrow slice.



**Figure 12.8 Figure Parts of M.B. Plow**

### **Plough accessories**

There are a few accessories necessary for plough such as (i) Jointer (ii) Coulter (iii) Gauge wheel (iv) Land wheel and (v) Furrow wheel.

- **Jointer** - It is a small irregular piece of metal having a shape similar to an ordinary plough bottom. It looks like a miniature plough. Its purpose is to turn over a small ribbon like furrow slice directly in front of the main plough bottom. This small furrow slice is cut

from the left and upper side of the main furrow slice and is inverted so that all trashes on the top of the soil are completely turned down and buried under the right hand corner of the furrow.

- **Coulter**- It is a device used to cut the furrow slice vertically from the land ahead of the plough bottom. It cuts the furrow slice from the land and leaves a clear wall. It also cuts trashes which are covered under the soil by the plough. The coulter may be (a) Rolling type disc coulter or (b) Sliding type knife coulter.
- **Gauge wheel**- It is an auxiliary wheel of an implement to maintain uniform depth of working. Gauge wheel helps to maintain uniformity in respect of depth of plowing in different soil conditions. It is usually placed in hanging position.
- **Land wheel** - It is the wheel of the plough, which runs on the ploughed land.
- **Front furrow wheel** - It is the front wheel of the plough, which runs in the furrow.
- **Rear furrow wheel** - It is the rear wheel of the plough, which runs in the furrow.

#### **Adjustment of Moldboard plough**

##### **Vertical suction (Vertical clearance)**

It is the maximum clearance under the land side and the horizontal surface when the plough is resting on a horizontal surface in the working position. It is the vertical distance from the ground, measured at the joining point of share and land side. (Fig.4). It helps the plough to penetrate into the soil to a proper depth. This clearance varies according to the size of the plough.

##### **Horizontal suction (Horizontal clearance)**

It is the maximum clearance between the land side and a horizontal plant touching point of share at its gunnel side and heel of land side. This suction helps the plough to cut the proper width of furrow slice. This clearance varies according to the size of the plough. It is also known as side clearance.

##### **Throat clearance**

It is the perpendicular distance between point of share and lower position of the beam of the plough.

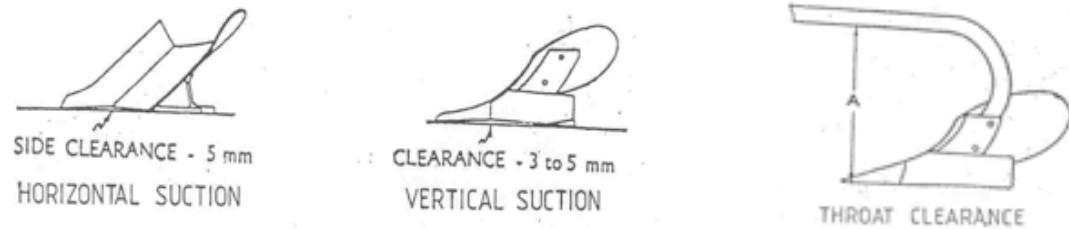

**Figure 12.9 Horizontal, vertical and throat clearance**

### Plough size

The size of the Moldboard plough is expressed by width of cut of the soil.

### Disc Plough

It is a plough, which cuts, turns and in some cases breaks furrow slices by means of separately mounted large steel discs. A disc plough is designed with a view of reduce friction by making a rolling plough bottom instead of sliding plough bottom. A disc plough works well in the conditions where mould board plough does not work satisfactorily.

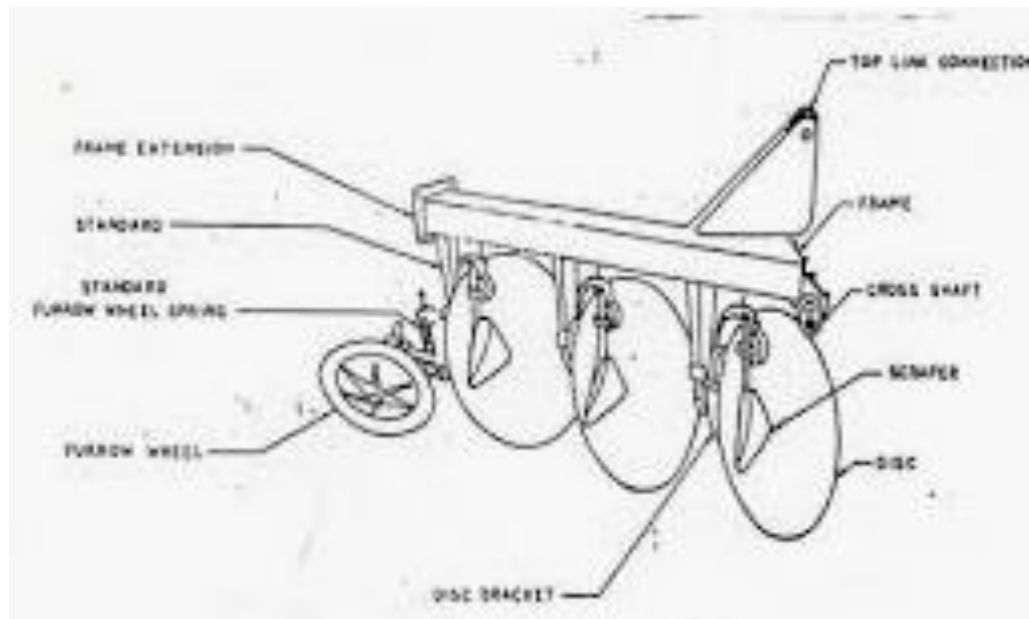

**Figure 12.10 Disk plow**

### Advantages of disc plough

1. A disc plough can be forced to penetrate into the soil which is too hard and dry for working with a mould board plough.
2. It works well in sticky soil in which a mould board plough does not scour.
3. It is more useful for deep plowing.

4. It can be used safely in stony and stumpy soil without much danger of breakage.
5. A disc plough works well even after a considerable part of the disc is worn off in abrasive soil.
6. It works in loose soil also (such as peat) without much clogging.

#### **Disadvantages of disc plough**

1. It is not suitable for covering surface trash and weeds as effectively as Moldboard plough does.
2. Comparatively, the disc plough leaves the soil in rough and more cloddy condition than that of Moldboard plough.
3. Disc plough is much heavier than Moldboard plough for equal capacities because penetration of this plough is affected largely by its weight rather than suction. There is one significant difference between Moldboard plough and disc plough i.e. Moldboard plough is forced into the ground by the suction of the plough, while the disc plough is forced into the ground by its own weight.

#### **Types of Disc Plough**

Disc ploughs are of two types (i) Standard disc plough and (ii) Vertical disc plough.

**(i) Standard disc plough** - It consists of steel disc of 60 to 90 cm diameter, set at a certain angle to the direction of travel. Each disc revolves on a stub axle in a thrust bearing, carried at the lower end of a strong stand which is bolted to the plough beam. The angle of the disc to the vertical and to the furrow wall is adjustable. In action, the disc cuts the soil, breaks it and pushes it sideways. There is little inversion of furrow slice as well as little burying of weeds and trashes. The disc plough may be mounted type or trailed type. In mounted disc plough, the side thrust is taken by the wheels of the tractor. Disc is made of heat treated steel of 5 mm to 10 mm thickness. The amount of concavity varies with the diameter of the disc. The approximate values being 8 cm for 60 cm diameter disc and 16 cm for 95 cm diameter.

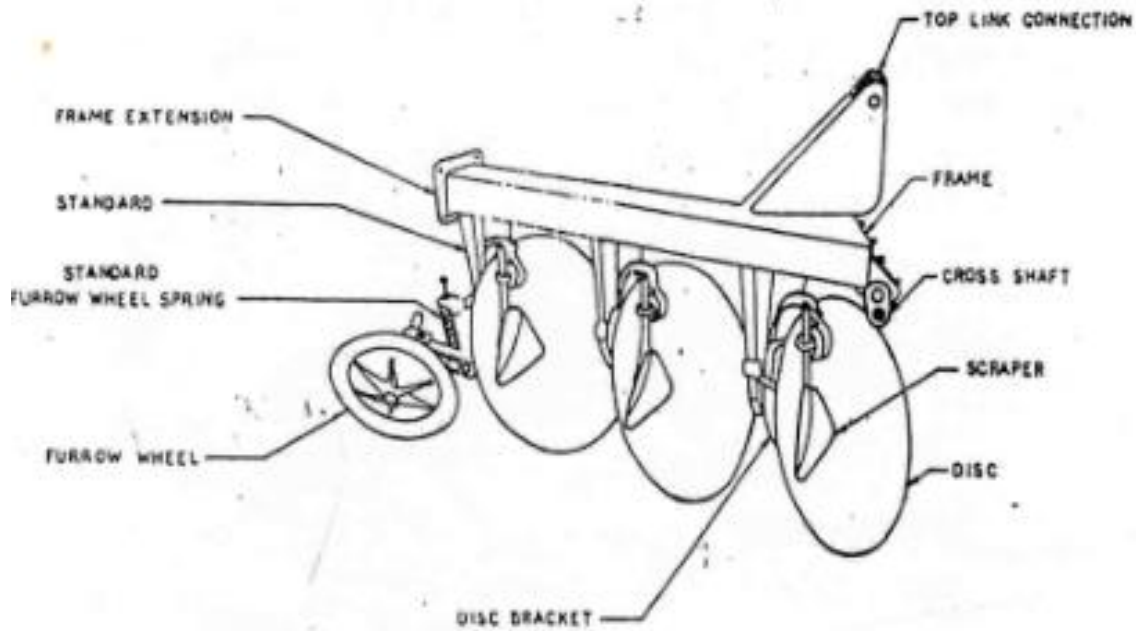

**Figure 12.9 Standard Disk plow**

A few important terms connected with disc plough is explained below

#### **Terminologies of disc plough**

**Disc** - It is a circular, concave revolving steel plate used for cutting and inverting the soil.

**Disc angle** - It is the angle at which the plane of the cutting edge of the disc is inclined to the direction of travel. Usually the disc angle of good plough varies between  $42^\circ$  to  $45^\circ$ .

**Tilt angle** - It is the angle at which the plane of the cutting edge of the disc is inclined to a vertical line. The tilt angle varies from  $15^\circ$  to  $25^\circ$  for a good plough.

**Scraper** - It is a device to remove soil that tend to stick to the working surface of a disc.

**Concavity** - It is the depth measured at the centre of the disc by placing its concave side on a flat surface.

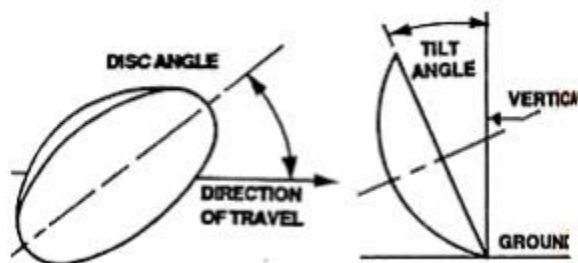

**12.10 Disk angle and tilt angle**

### Vertical Disc Plough

It is the plough which combines the principle of regular disc plough and disc harrow and is used for shallow working in the soil.

### Draft of disc plough

The disc plough is lighter in draft than the Moldboard plough, turning same volume of soil in similar conditions. In very hard soil, some extra weight is added to the wheel which increases the draft.

**Rotary tiller** - The rotary cultivator is widely considered to be the most important tool as it provides fine degree of pulverization enabling the necessary rapid and intimate mixing of soil besides reduction in traction demanded by the tractor driving wheels due to the ability of the soil working blades to provide some forward thrust to the cultivating outfit. Rotary tiller is directly mounted to the tractor with the help of three point linkage. The power is transmitted from the tractor PTO (Power Take Off) shaft to a bevel gear box mounted on the top of the unit, through telescopic shaft and universal joint. From the bevel gear box the drive is further transmitted to a power shaft, chain and sprocket transmission system to the rotor. The tynes are fixed to the rotor and the rotor with tynes revolves in the same direction as the tractor wheels. The number of tynes varies from 28 - 54. A leveling board is attached to the rear side of the unit for leveling the tilled soil. A depth control lever with depth wheel provided on either side of the unit ensures proper depth control.



**Figure 12.11 Rotary Tiller**

The following types of blades are used with the rotor.

- **'L' type blade** - Works well in trashy conditions, they are more effective in cutting weeds and they do not pulverize the soil much.

- **Twisted blade** - Suitable for deep tillage in relatively clean ground, but clogging and wrapping of trashes on the tynes and shafts.
- **Straight blade** - Employed on mulchers designed mainly for secondary tillage.

### Chisel plough

Chisel ploughs are used to break through and shatter compacted or otherwise impermeable soil layers. Deep tillage shatters compacted sub soil layers and aids in better infiltration and storage of rainwater in the crop root zone. The improved soil structure also results in better development of root system and the yield of crops and their drought tolerance is also improved. The functional component of the unit include reversible share, tyne (chisel), beam, cross shaft and top link connection.

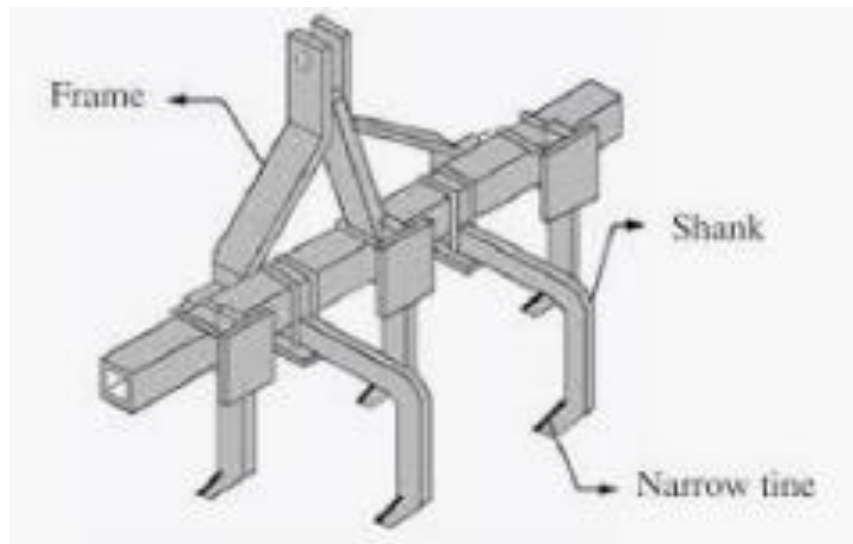

**Figure 12.12 Chisel Plow**

**Sub-Soil plough** - The function of the sub-soiler is to penetrate deeper than the conventional cultivation machinery and break up the layers of the soil, which have become compacted due to the movement of heavy machinery or as a result of continuous plowing at a constant depth. These compacted areas prevent the natural drainage of the soil and also inhibit the passage of air and nutrients through the soil structure. The sub-soiler consists of heavier tyne than the chisel plough to break through impervious layer shattering the sub-soil to a depth of 45 to 75 cm and requires 60 to 100 hp to operate it. The advantages are same as that of chisel plough.

### Plowing System

- **Normal Plowing:** It is the plowing up to a depth of about 15 cm.

- **Contour Plowing:** It is the method of plowing in which the soil broken and turned along the contours.

### Plowing of Land

The plowing of land separates the top layer of soil into furrow slices. The furrows are turned sideways and inverted to a varying degree, depending upon the type of plough being used. It is a primary tillage operation, which is performed to shatter soil uniformly with partial or complete soil inversion. There are a few important terms frequently used in connection with plowing of land.

- (i) **Furrow** - It is a trench formed by an implement in the soil during the field operation.
- (ii) **Furrow slice** - The mass of soil cut, lifted and thrown to one side is called furrow slice.
- (iii) **Furrow wall** - It is an undisturbed soil surface by the side of a furrow.
- (iv) **Crown** - The top portion of the turned furrow slice is called crown.
- (v) **Back furrow** - A raised ridge left at the centre of the strip of land when plowing is started from centre to side is called back furrow. When the plowing is started in the middle of a field, furrow is collected across the field and while returning trip another furrow slice is lapped over the first furrow. This is the raised ridge which is named as back furrow.
- (vi) **Dead furrow** - An open trench left in between two adjacent strips of land after finishing the plowing is called dead furrow.
- (vii) **Head land** - While plowing with a tractor to turn, a strip of un ploughed land is left at each end of the field for the tractor to turn, that is called head land. At the end of each trip, the plough is lifted until the tractor and the plough have turned and are in position to start the return trip. The head land is about 6 meters for two or three bottom tractor plough and one meter more for each additional furrow.

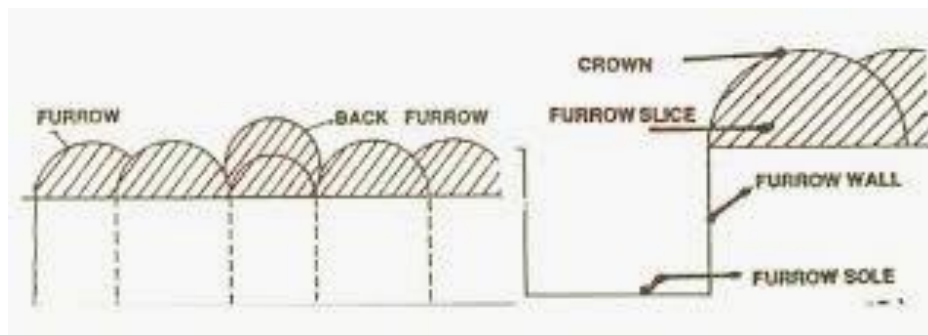

**Figure 12.13 Land Furrow components**

### Terminology of plough

- **Centre of power** - It is the true point of hitch of a tractor.
- **Centre of resistance** - It is the point at which the resultant of all the horizontal and vertical forces act. The centre lies at a distance equal to 3/4th size of the plough from the share wing.
- **Line of pull**- It is an imaginary straight line passing from the centre of resistance through the clevis to the centre of pull (power).
- **Pull**- It is the total force required to pull an implement.
- **Draft** - It is the horizontal component of the pull, parallel to the line of motion.
- Draft depends upon 1) sharpness of cutting edge 2) working speed 3) working width 4) working depth 5) type of implement 6) soil condition and 7) attachments.
- **Side draft** - It is the horizontal component of the pull perpendicular to the direction of motion. This is developed if the centre of resistance is not directly behind the centre of pull.
- **Unit draft** - It is the draft per unit cross sectional area of the furrow.

### Theoretical field capacity

It is the rate of field coverage of the implement, based on 100 per cent of time at the rated speed and covering 100 per cent of its rated width.

$$TFC = \frac{S.W}{10}$$

### Effective field capacity

It is the actual area covered by the implement based on its total time consumed and its width.

$$TFC = \frac{S.W.E}{10}$$

Where

C = effective field capacity, hectare per h.

S = speed of travel in km per hour.

W = theoretical width of cut of the machine in meter, and

E = field efficiency in percent.

### Field efficiency

It is the ratio of effective field capacity and theoretical field capacity expressed in percent.

### Soil pulverization

It is the quality of work in terms of soil aggregates and clod size. This is measured by cone penetrometer.

### Methods of Plowing a Land

There are two main methods of plowing a field which are known as “inlands” and “round about” plowing

A normal right hand plough must always have an open furrow on the right in which to lay the next furrow slice. It is therefore, necessary to travel across the field in one place and come back in another. There are two ways of doing this by “gathering” and “casting”

#### Gathering

Whenever a plough works round a strip of ploughed land, it is said to be gathering. The tractor and plough turns to right each time the head land is reached. When the land is ploughed, a raised ridge (double width ridge) is formed in the center of the field. This however would be uneconomical way of working as time is wasted at the start in making awkward turns, while later, total idle running would be increased along the head land

#### Casting

Whenever a plough works round a strip of un ploughed land, it is said to be casting. The tractor and plough turns to the left each time the head land is reached. When the land is ploughed in this way a wide furrow (double width furrow) will be left in the center and is termed as ‘finish’ or open furrow or dead furrow

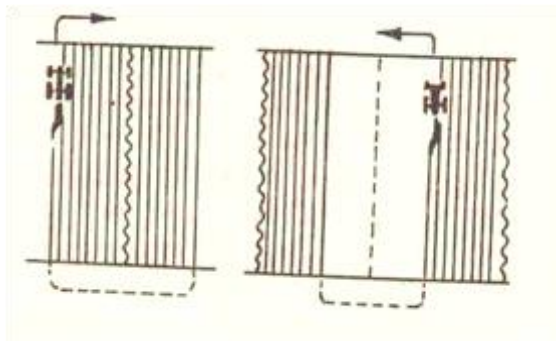

a.. Gathering

b. Casting

### Figure 12.14 Gathering and Casting

It is recommended that long field should be ploughed by gathering in one season and casting in another season. It avoids building up of a ridge in the centre and an open furrow at each side or vice versa. However, plowing of a field either by casting or by gathering alone is normally uneconomical. For economical plowing the following methods are used.

### a) Continuous plowing method

In normal conditions, the continuous plowing method is considered very convenient and economical. This is a method usually used in which the tractor and plough never run idle for more than three quarter land width along the headland and never turn in a space narrower than a quarter land width. In this method, first the headland is marked and the first ridge is set up at three quarter of a land width from the side (Fig. a). The other ridges are set at full width over the field. The operator starts plowing between the first ridge and the side land. The operator continues to turn left and cast in the three quarter land until plowing is completed in a quarter land width on each side (Fig. b). At this stage, the plough is lifted to half depth for the last trip down the side land of the field. This leaves a shallow furrow where the finish comes.

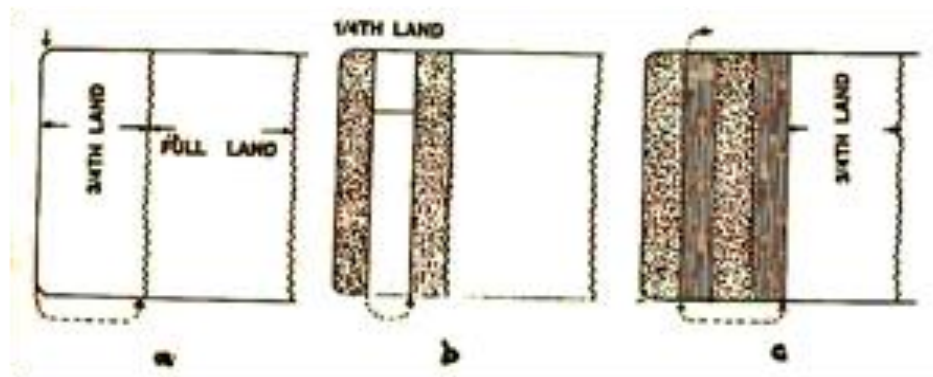

**Figure 12.15 Continuous plowing method**

After this stage, the driver turns right and gathers round the one fourth land already ploughed. Gathering is continued till the un ploughed strip in first three-quarter land is ploughed and completed. This gathering reduces the first full land by a quarter (Fig. c). The remaining three quarter land can be treated in exactly the same manner as the original three quarter land completed earlier. This process is repeated for all other lands in the field.

### b) Round and round plowing

In this method, the plough moves round and round in a field. This system is adopted under conditions where ridges and furrows interfere with cultivation work. The field can be started in two ways.

#### a) Starting at the centre

A small plot of land is marked in the middle of the field and it is ploughed first. After that, the plough works round this small plot and the entire plot is completed. This is not a very economical method.

**b) Starting at the outer end**

Tractor starts plowing at one end of the field and then moves on all the sides of the field and comes gradually from the sides to the centre of the field. Wide diagonals are left unploughed to avoid turning with the plough. There are no back furrows in this method. Conventional plowing is usually done by this method.

**c) One way plowing**

This system requires the use of a special type of plough known as reversible plough or one way plough. Such a plough turns furrows to the left or right. After the head land has been marked, the operator plough along a straight side land mark. At the end of the first trip, he turns his tractor in a loop and returns down the same furrow. No dead and back furrows are left in the field. In gently sloping fields, this method is suitable.

**PROBLEMS**

**Problem.1.** A 5 x 20 cm double action disc harrow is operated by a tractor having a speed of 5 km/h. Calculate the actual field capacity , assuming the field efficiency of 80 percent (0.8).

**Solution:**

Size of the harrow (width) = 5 x 20 = 100 cm = 1 m

$$EFC = \frac{S.W.E}{10} = \frac{5 \times 1 \times 0.8}{10} = 0.4 \text{ ha/h}$$

**Problem 2.** A 3 x 30 cm plough is moving at a speed of 4 km/h. calculate how much time it take to plough 500 x 500 m field when the field efficiency is 70 %.

Solution :

Width of the plough = 3 x 30 = 90 cm = 0.9 m

$$\text{Effective field capacity} = (0.9 \times 4 \times 0.70) / 10 = 0.25 \text{ ha/h} = 2500 \text{ m}^2/\text{h}$$

$$\text{Time required} = (500 \times 500) \text{ m}^2 / (2500 \text{ m}^2 / \text{h}) = 100 \text{ h}$$

**Problem 3.** A 4 bottom 40 cm mould board plough is operating at 5.5 km/h speed with 75 % field efficiency. Calculate what is the rate of doing work in hectares per hour.

**Solution:**

Width of the plough = 4 x 40 = 160 cm = 1.6 m

$$\text{Area covered} = 1.6 \times 5.5 \times 0.75 / 10 = 0.66 \text{ ha/h}$$

**Problem. 4.** An indigenous plough has a 20 cm wide furrow at the top and 10 cm depth. Calculate the volume of soil handled per day 8 hours if the speed of working is 2.5 km/h.

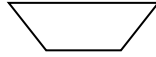
**Solution:**

$$\text{Furrow cross section} = 10 \times 20 / 2 = 100 \text{ cm}^2$$

$$\text{Distance traveled in 8 hours} = 8 \text{ h} \times 2.5 \text{ km/h} \times 1000 \text{ m/km} = 20,000 \text{ m}$$

$$\text{Volume of soil handled} = 20000 \text{ m} \times 100 \text{ cm}^2 / (10000 \text{ cm}^2/\text{m}^2) = 200 \text{ m}^3$$

**Problems**

1. A three bottom 40 cm M.B plough is working at a speed of 4 km/h . Calculate the effective field capacity if the field efficiency is 80 percent.
2. A four bottom 30 cm M.B plough is working at a speed of 4.5 km/h. Calculate the actual field capacity if the field efficiency is 70 percent.

**SECONDARY TILLAGE***By**Engr. Prof. Dr. Muhammad Iqbal, Subject Expert**Engr. Prof. Dr. Manzoor Ahmad, Subject Expert*

Tillage operations following primary tillage which are performed to create proper soil tilth for seeding and planting are secondary tillage. These are lighter and finer operations, performed on the soil after primary tillage operations. Secondary tillage consists of conditioning the soil to meet the different tillage objectives of the farm. These operations consume less power per unit area compared to primary tillage operations. Secondary tillage implements may be tractor drawn or bullock drawn implements.

**13.1 Harrow**

Harrow is a secondary tillage implement that cuts the soil to a shallow depth for smoothening and pulverizing the soil as well as to cut the weeds and to mix the materials with the soil. There are several types of harrow used in India such as disc harrow, spike tooth harrow, spring tooth harrow, acme harrow, patela, triangular harrow, bade harrow, guntaka and reciprocating power harrow.

**Disc harrow**

It is a harrow, which performs the harrowing operation by means of a set, or a number of sets of rotating slat discs, each set being mounted on a common shaft. Disc harrow is found very suitable for hard ground, full of stalks and grasses. It cuts the lumps of soil, clods and roots. Disc are mounted on one, two or more axles which may be set at a variable angle to the line of motion. As the harrow is pulled ahead, the discs rotate on the ground. Depending upon the disc arrangements, disc harrows are divided into two classes a) Single action and b) Double action.

- **Single action disc harrow** - It is a harrow with two gangs placed end to end, which throw the soil in opposite directions. The discs are arranged in such a way that right side gang throws the soil towards right and left side gang throws the soil towards left.
- **Tandem disc harrow** - It is a disc harrow comprising of four gangs in which each gang can be angled in opposite direction.

- **Off-set disc harrow-** It is a disc harrow with two gangs in tandem, capable of being off-set to either side of the centre line of pull. Two gangs are fitted one behind the other. The soil is thrown in both directions because discs of both gangs face in opposite directions.

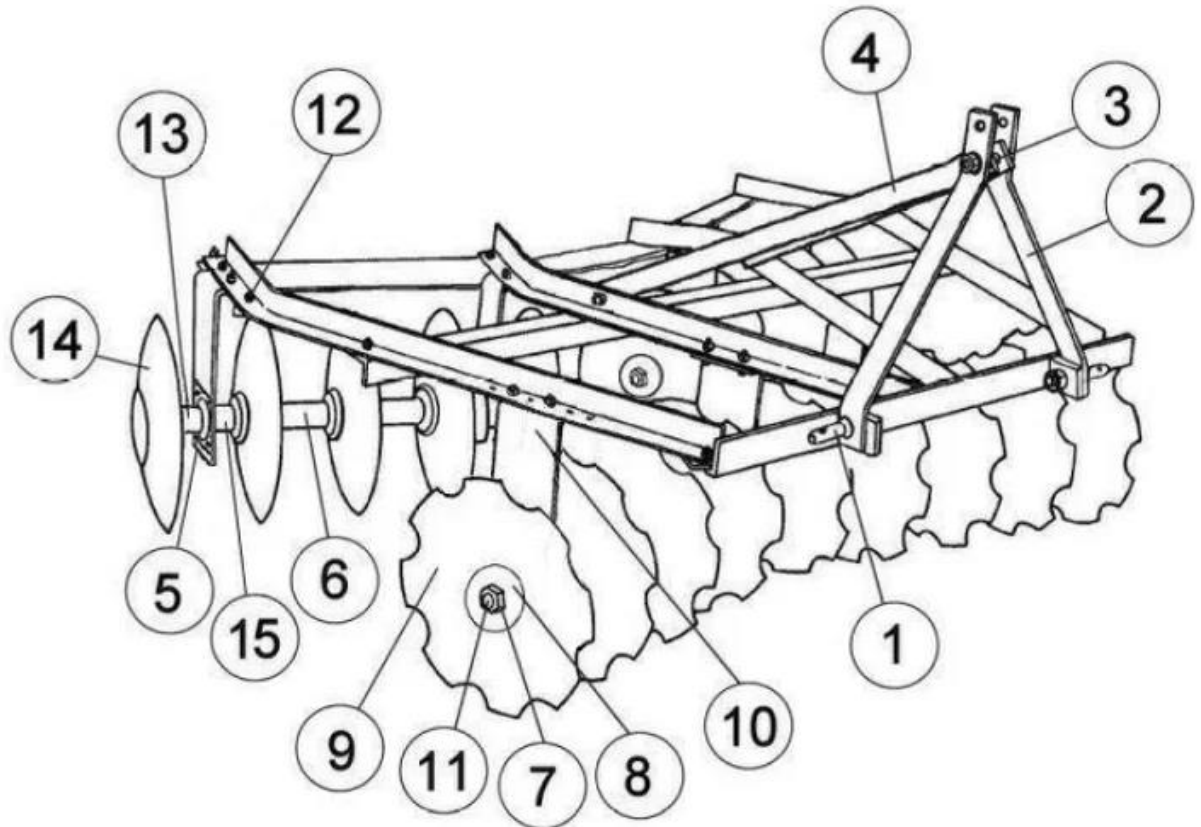

**Figure 13.1 Types of disk harrow**

**Parts of a disk harrow** - A disc harrow mainly consists of disc, gang, gang bolt, gang central lever, spool or arbor bolt or spacer, bearings, transport wheels, scraper and weight box.

- **Disc:** It is a circular concave revolving steel plate used for cutting and inverting the soil. Disc is made of high quality heat-treated hardened steel. Tractor drawn disc harrows have concave discs of size varying from 35-70 cm diameter. Concavity of the disc affects penetration and pulverization of soil. Usually two types of disc are used in disc harrows, plain disc and cut away disc.
- **Gang:** Each set of discs that are mounted on a common shaft is called the gang.
- **Gang bolt or arbor bolt:** It is a long heavy square headed bolt from the other end, a set of discs are mounted on the gang bolt. The spacing between the discs on the gang bolt ranges from 15 to 25 cm for light duty and 25 to 30 cm for heavy-duty harrows.
- **Gang control lever:** A lever, which operates the gang mechanisms of the disc harrow, is called the gang control lever.
- **Spool or spacer:** The flanged tube, mounted on the gang bolt between every two discs to prevent the lateral movement of the disc on the shaft is called the "spool" or "spacer".
- **Bearing:** Bearing is essential to counteract the end thrust of the gang due to soil thrust. The harrow bearings are subjected to heavy radial and thrust loads. Chilled cast iron bearings are used to handle heavy radial and thrust loads and they are also used due to their durability.
- **Transport wheel:** In trailing type disc harrow, the transport wheels are provided for transport work on roads and for preventing the edges of the discs from damage. Mounted type disc harrows do not require wheels for transport work.

- **Scraper:** It prevents disc from clogging. It removes the soil that may stick to the concave side of the disc.
- **Weight box:** A box like frame is provided on the main frame of the harrow for putting additional weight on the implement. Additional weight helps in increasing the penetration of the disc in the soil.



**Figure 13.2 Parts of disk harrow**

A sharp edged disc has more effective penetration compared to blunt edged disc. It is observed that penetration is better in low speed than in high speed. The following are a few adjustments for obtaining higher penetration:

- By increasing the disc angle
- By adding additional weight in harrow
- By lowering the hitch point
- By using the sharp edged discs of small diameter and losses concavity
- By regulating the optimum speed.

### **Spike tooth harrow**

It is a harrow with peg shaped teeth of diamond cross section to a rectangular frame.

It is used to break the clod, stir the soil, uproot the weeds, level the ground, break the soil and cover the seeds. Its principle is to smoothen and level the soil directly after plowing. Spike tooth harrows may be of rigid type and flexible type. Tractor drawn harrows are usually flexible type. It has got the advantage of being turned up for transporting purpose.

This harrow mainly consists of teeth, tooth bar frame, clamps, guard, braces, levers and hooks.

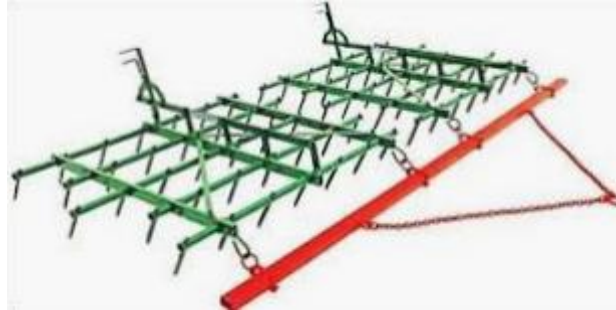

**Figure 13.3 Spike tooth harrow**

### **Spring tooth harrow**

It is a harrow with tough flexible teeth, suitable to work in hard and stony soils. Spring tooth harrow is fitted with springs having loops of elliptical shape. It gives a spring action in working condition. It is used in the soil when obstruction like stone, roots and weeds are hidden below the ground surface. This type pulverizes the soil and helps in killing weeds. The levers are provided for setting the teeth for varying the depth of harrowing. For light harrowing, the adjustment is done in slanting position. Draft hooks on each corner of every section for hitching purpose.

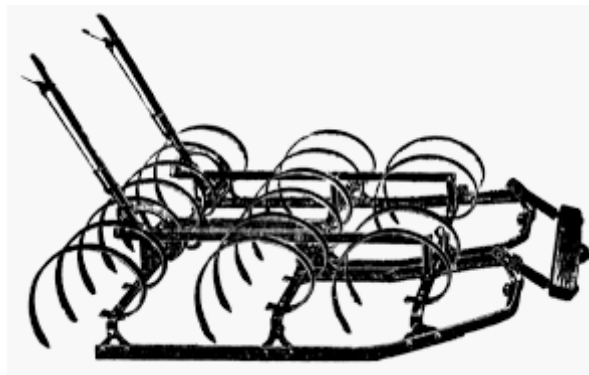

**Figure 13.4 Spring tooth harrow**

### **Bund former**

It is used for making bunds or ridges by collecting the soil. Bunds are required to hold water in the soil, thereby one can conserve moisture and prevent run-off. The size of the bund former is determined by measuring the maximum horizontal distance between the two rear ends of the farming boards. Bund former consists of forming board, beam and handle.



**Figure 13.5 Bund former**

### **Ridger**

It is an implement importantly used to form ridges required for sowing row crop seeds and plants in well-tilled soil. The ridger is also used for forming field or channels, earthing up and similar other operations. Ridger is also known as ridging plough and double mould board plough. The ridger generally has 'V' shaped or wedge shaped share fitted to the frog. The nose or tip of share penetrates into the soil and breaks the earth. The mould boards lift, invert and also cast aside the soil, forming deep channels and ridges of the required size. A ridger consists of beam, clevis, frog, handle, mould boards, share and sliding share.



**Figure 13.6 Ridger**

### **Puddler**

Puddler is an implement for churning the soil with water. It is used to prepare paddy

fields with standing water after initial plowing with country plough. It breaks up the clods and churns the soil. The main purpose of puddling is to reduce leaching of water or decrease

### **Leveller**

Land levelling is expected to bring permanent improvement in the value of land.

Levelling work is carried out to modify the existing contours of land so as to achieve certain objectives desired for efficient agricultural production system. These objectives include

- (i) efficient application of irrigation water,
- (ii) improved surface drainage,
- (iii) minimum soil erosion
- (iv) increased conservation of rain water specially on dry lands and
- (v) provision of an adequate field size and even topography for efficient mechanization.



**Figure 13.7 Tractor drawn Leveller**

### **Cultivators**

It is an implement for inter cultivation with laterally adjustable tines or discs to work between crop rows. The cultivator stirs the soil, and breaks the clods. The tines fitted on the frame of the cultivator comb the soil deeply in the field. A cultivator performs functions intermediate between those of plough and the harrow. Destruction of weeds is the primary function of a cultivator. The following are a few important functions performed by a cultivator.

1. Interculture the fields.
2. Destroy the weeds in the field.
3. Aerate the soil for proper growth of crops.
4. Conserve moisture by preparing mulch on the surface.
5. To sow seeds when it is provided with sowing attachments.
6. To prevent surface evaporation and encourage rapid infiltration of rain water into the soil.

The cultivator can be 1) Disc cultivator, 2) Rotary cultivator, 3) Tine cultivator.



Disc cultivator



Rotary cultivator



Tine cultivator

**Figure 13.8 Cultivators**

**Disc cultivator :** It is a cultivator fitted with discs.

**Rotary cultivator :** It is a cultivator with tines or blades mounted on a power driven horizontal shaft.

**Tine cultivator :** It is a cultivator fitted with tines having shovels.

#### **Trailed type cultivator**

It consists of a main frame which carries a number of cross members to which tines are fitted. At the forward end of the cultivator, there is a hitch arrangement for hitching purpose. A pair of wheels are provided in the cultivator. The height of the hitch is adjusted so that main frame remains horizontal over a range of depth setting. The tines in each row are spaced widely to allow free passage of the soil and trash around them. The tines in subsequent rows are staggered so that the implement can cover the entire width nicely.

#### **Mounted Cultivator**

Tractors fitted with hydraulic lift operate the mounted type cultivators. A rectangular frame of angle iron is mounted on three point hydraulic linkage of the tractor. The cross members carry the tines in two staggered lines. Depending upon the type of soil and crop, shovels are chosen for use on the cultivators. Usually tractor drawn cultivators are of two types, depending upon the flexibility and rigidity of tines (i) Cultivator with spring loaded tines (ii) Cultivator with rigid tynes.

#### **Cultivator with spring loaded tines**

A tine hinged to the frame and loaded with a spring so that it swings back when an obstacle is encountered, is called spring loaded line. Each of the tine of this type of cultivator

is provided with two heavy coil springs, pre-tensioned to ensure minimum movement except when an obstacle is encountered. The springs operate, when the points strike roots or large stones by allowing the tines to ride over the obstruction, thus preventing damage. On passing over the obstruction, the tines are automatically reset and work continues without interruption. The tines are made of high carbon steel and are held in proper alignment on the main frame members. This type of cultivator is particularly recommended for soils which are embedded with stones or stumps.

### **Cultivator with rigid tines**

Rigid tines of the cultivators are those tines which do not deflect during the work in the field. The tynes are bolted between angle braces, fastened to the main bars by sturdy clamps and bolts . Spacing of the tines is changed simply by slackening the bolts and sliding the braces to the desired position. Since rigid tines are mounted on the front and rear tool bars, the spacing between the tynes can be easily adjusted without getting the tines choked with stubbles of the previous crop or weed growth. A pair of gauge wheel is used for controlling the depth of operation.

## SOWING MACHINERY

*Engr. Prof. Dr. Muhammad Iqbal, Subject Expert*

*Engr. Prof. Dr. Manzoor Ahmad, Subject Expert*

Seeding or sowing is an art of placing seeds in the soil to have good germination in the field. A perfect seeding gives

- a. Correct amount of seed per unit area.
- b. Correct depth at which seed is placed in the soil.
- c. Correct spacing between row-to-row and plant-to-plant.

### 14.1 Sowing methods

**(i) Broadcasting** - Broadcasting is the process of random scattering of seed on the surface of seedbeds. It can be done manually or mechanically both. When broadcasting is done manually, uniformity of seed depends upon skill of the man. Soon after broadcasting the seeds are covered by planking or some other devices. Usually higher seed rate is obtained in this system. Mechanical broadcasters are used for large-scale work. This machine scatters the seeds on the surface of the seedbed at controlled rates.

**(ii) Dibbling** - Dibbling is the process of placing and seeds in holes made in seedbed and covering them. In this method, seeds are placed in holes make at definite depth at fixed spacing. The equipment used for dibbling is called dibbler. It is a conical instrument used to make proper holes in the field. Small hand dibblers are made with several conical projections made in a frame. This is very time consuming process, so it is not suitable for small seeds. Mostly vegetables are sown in this way.



**Figure 14.1 Dibbler**

**(iii) Drilling** - Drilling consists of dropping the seeds in furrow lines in a continuous flow and covering them with soil. Seed metering may be done either manually or mechanically. The number of rows planted may be one or more. This method is very helpful in achieving proper depth, proper spacing and proper amount of seed to be sown in the field. Drilling can be done by (1) Sowing behind the plough (2) Bullock drawn seed drills (3) Tractor drawn seed drills.



**Wheat Seed Drill**



**Seed cum fertilizer drill**



**Planter for corn**

**Figure 14.2 Sowing and planting machines**

**(iv) Seed dropping behind the plough** - It is very common method used in villages. It is used for seed like maize, gram, peas, wheat and barley. A man drops seeds in the furrow behind the plough. Sowing behind the plough can be done by a device known as malobansa. It consists of a bamboo tube provided with a funnel shaped mouth. One man drops the seeds through the funnel and other man handles the plough and the bullocks. This is a slow and laborious method.

**(v) Transplanting** - Transplanting consists of preparing seedlings in nursery and then planting these seedlings in the prepared field. It is commonly done for paddy, vegetable and flowers. It is very time consuming operation. Equipment for placing plants in the soil is called transplanter.

**(vi) Hill dropping** - In this method, seeds are dropped at fixed spacing and not in a continuous stream. Thus the spacing between plant to plant in a row is constant. In case of drills, the seeds are dropped in continuous stream and the spacing between plant to plant in a row is not constant.

## **Seed Drill**

Seed drill is a machine for placing the seeds in a continuous flow in furrows at uniform rate and at controlled depth with or without the arrangement of covering them with soil.

**Function of seed drill:** Seed drill performs the following functions

- To carry the seeds.
- To open furrow to an uniform depth

- To meter the seeds
- To place the seed in furrows in an acceptable pattern
- To cover the seeds and compact the soil around the seed.

### **Seed cum fertilizer drill**

Seed drills, fitted with fertilizer dropping attachment, distribute the fertilizer uniformly on the ground. It is called seed cum fertilizer drill. Such a drill has a large seed box which is divided lengthwise into two compartments, one for seed and another for fertilizers. Seed drill may be classified as (i) Bullock drawn (ii) Tractor drawn.

### **Components of Seed Drill**

A seed drill with mechanical seed metering device mainly consists of : (i) Frame (ii) Seed box (iii) Seed metering mechanism (iv) Furrow openers (v) Covering device (vi) Transport wheels.

- **Frame:** The frame is usually made of angle iron with suitable braces and brackets. The frame is strong enough to withstand all types of loads in working condition.
- **Seed box :**It may be made of mild steel sheet or galvanized iron with a suitable cover. A small agitator is sometimes provided to prevent clogging of seeds.
- **Covering device:** It is a device to refill a furrow after the seed has been placed in it. Covering the seeds are usually done by patta, chains, drags, packers, rollers or press wheels, designed in various sizes and shapes.
- **Transport wheel:** There are two wheels fitted on the main axle. Some seed drills have got pneumatic wheels also. The wheels have suitable attachments to transmit power to operate seed dropping mechanism.

### **SEED METERING MECHANISM**

The mechanism of a seed drill or fertilizer distributor which delivers seeds or fertilizers from the hopper at selected rates is called seed metering mechanism. Seed metering mechanism may be of several types:

(a) Fluted feed type (b) Internal double run type (c) Cup feed type (d) Cell feed mechanism (e) Brush feed mechanism (f) Auger feed mechanism (g) Picker wheel mechanism (h) Star wheel mechanism.

**(a) Fluted feed type-** It is a seed metering device with adjustable fluted roller to collect and deliver the seeds into the seed tube. Fluted feed type mechanism consists of a fluted wheel, feed roller, feed cut-off and adjustable gate for different sizes of grains. The feed roller and the feed

cut-off device are mounted a shaft, running through the feed cups. The roller carries grooves throughout its periphery. It rotates with the axle over which it is mounted throws the grains out on the adjustable gate from where it falls into the seed tube. The fluted rollers which are mounted at the bottom of the seed box, receive seeds into longitudinal grooves and pass on to the seed tube through the holes provided for this purpose. By shifting the fluted wheel side ways, the length of the grooves exposed to the seed can be increased or decreased and hence the amount of seed is controlled.

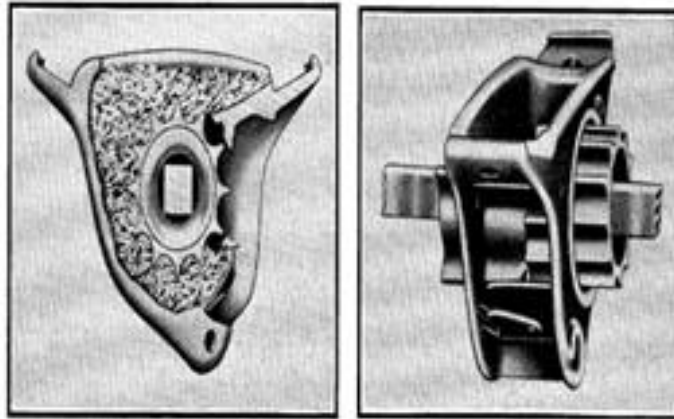

**Figure 14.3 Fluted feed type seed metering device**

**(b) Internal double run type-** It is a seed metering device in which the feed wheel is provided with fine and coarse ribbed flanges. It consists of discs, mounted on a spindle and housed in a casing fitted below the seed box. It has double faced wheel. Internal double-run type roller one face has a larger opening for larger seeds and the other face has smaller opening for smaller seeds. A gate is provided in the bottom-of the box to cover the opening not in use. The rate of seeding is varied by adjusting the speed of the spindle which carries the discs.

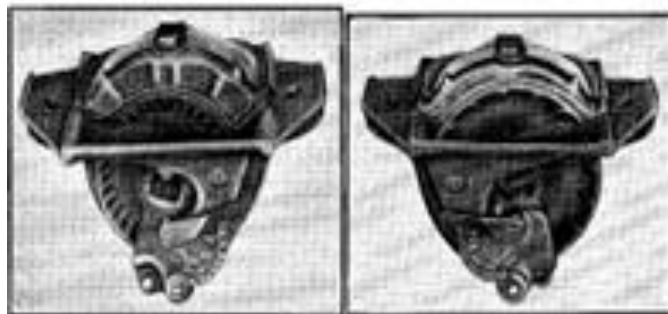

**Figure 14.4 Internal double run type seed metering device**

**(c) Cup feed mechanism-** It is a mechanism consisting of cups or spoons on the periphery of a vertical rotating disc which picks up the seeds from the hopper and delivers them into the seed

tubes. It consists of a seed hopper which has two parts. The upper one is called grain box and the lower one is called feed box. The seed delivery mechanism consists of a spindle, carrying a number of discs with a ring of cups attached to the periphery of each disc (Figure 14.5). The spindle with its frame and attachment is called seed barrel. When the spindle rotates, one disc with its set of cups rotates and picks up few seeds and drops them into small hoppers. The cups have two faces, one for larger seeds and the rate at which the seed barrel revolves. This type of mechanism is common on British seed drills.

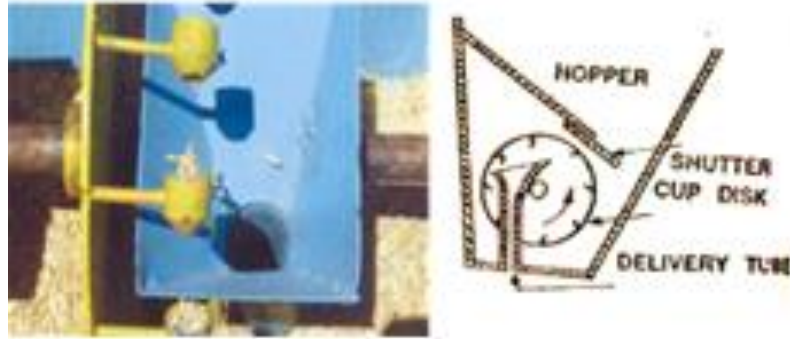

**Figure 14.5 Cup feed mechanism**

## **Furrow Openers**

The furrow openers are provided in a seed drill for opening a furrow. The seed tube conducts the seed from the feed mechanism into the boot from where they fall into the furrows.

### **Type of Furrow Openers**

Different type of furrow openers are: (1) Shovel type (2) Shoe type (3) Disc Type (single disc, double disc).

- (1) **Shovel Type-** Shovel type furrow opener are widely used in seed drills. There are three of shovels in use. They are: (a) reversible shovel (b) single point shovel and (c) spear point shovel. Shovel type openers are best suited for stony or root infested fields. These shovels are bolted to the flat iron shanks at the point where boots are fitted which carry the end of the seed tubes. In order to prevent shock loads due to obstructions, springs are provided. It is easy in construction, cheaper and easily repairable. It is very common with usual seed drill.
- (2) **Shoe Type-** It works well in trashy soils where the seed beds are not smoothly prepared. They are made from two flat pieces of steel welded together to form a cutting edge. It is specially suited for black cotton soil. Shoe is made of carbon steel having minimum carbon content of 0.5 per cent with a minimum thickness of 4 mm.

**(3) Disc Type-** They are two types: (a) Single disc type and (b) Double disc type.

- **Single disc type-** It is furrow opener consisting of one concave disc. Disc type furrow openers are found suitable where plant debris or trash mulches are used.
- **Double disc type-** In double disc type furrow opener there are two flat discs, set at an angle to each other. It is suitable for trashy lands. Seed drills attached with tractors having high speeds, usually use this type of furrow opener. The furrow opener consists of: (1) tine (2) shovel (3) seed tube (4) boot for seed and fertilizer.

**Shovel** - It is made of carbon steel having carbon content of 0.5 per cent and a minimum thickness of 4.0 mm.

**Seed tube** - It is a tube which carries the seeds from the metering device to the boot. Seed tubes are provided at the lowest lines through suitable boots and furrow openers. The minimum diameter of seed tube is 25 mm.

**Boot** - It is a part of the sowing machine which conveys the seeds or fertilizers from the delivery tube to the furrow. It is bolted or welded to the tine.

## **Planter**

Planter is normally used for those seeds which are larger in size and can not be used by usual seed drills. A planter consists of: (i) hopper (ii) feed metering device (iii) knock out arrangement (iv) cut-off mechanism (v) furrow opener and (vi) other accessories. A planter has seed hopper for each row.

**Seed metering device in a planter:** There are a number of seed metering devices in a planter but the most common device consist of a rotating plate at the bottom of seed hoppers. In some planters, vertical rotors as well as inclined rotors are also used. The most common is the horizontal seed plate used in planters. The horizontal seed plates have got suitable notches or holes called cell. Depending upon the type of notches on the plates, it is of three types. (i) Edge drop (ii) Flat drop (iii) Hill drop. The edge drop carries the seed on edge in the cell of the plate. The flat drop carries the seed on a flat in the cell of the plate. In hill drop, the cells round the edge of the plate are large enough to admit several seeds at a time. Planter is usually used for those seeds which are required to be sown at equal intervals between plant to plant.

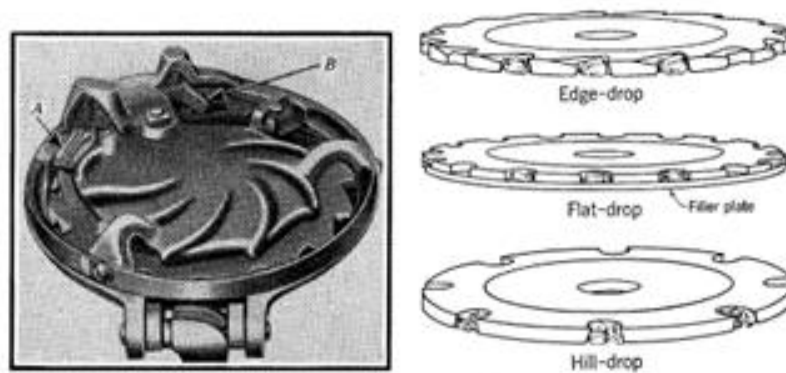

**Figure 14.6 Seed metering device in a planter**

### **Manual Rice Planter**

It is used for transplanting of paddy seedlings. The unit consists of skid frame, movable tray and seed picking fingers. Mat type seedlings are placed on the inclined trays. When the fingers are pushed downward they pick up the seedlings and place them in the ground. Seedlings are left on the ground during return stroke. The plant to plant spacing can be controlled by the opener. It may be 5-6 rows with comb type finger. Its working capacity may be 0.2 – 0.25 ha/8 hrs.

### **Rice Transplanter**

The rice transplanter consists of (i) Air cooled gasoline engine (ii) Main clutch (iii) Running clutch (iv) Planting clutch (v) Seeding table (vi) Float (vii) Starwheel (viii) Accelerator lever (ix) Ground wheel (x) Handle (xi) Four bar linkage mechanism

**Seedlings:** Growing of seedlings for this transplanter is most technical and difficult work. Seedlings are grown in special seedling trays. It is called mat seedling. Mat seedlings are grown by some standard procedure in controlled environment in a nursery.

**Operation:** The seedlings are raised in special trays as mat seedlings. The mat seedlings are placed on the seeding table of the transplanter in slanting position. When the engine is started, the running clutch and planting clutch are operated. Four bar linkage mechanism is there to catch 3 or 4 seedlings at a time and to separate them from the mat and fix in the puddled soil. A float is there to support the machine on the water while working in the field. There are two ground wheels made of iron for facilitating the movement of the transplanter. There is a marker also which demarcates the transplanting width while in operation. Power from the engine goes to the main clutch from where it is divided into two routes, one goes to planting clutch and the other goes to running clutch. Unless planting clutch is operated, the four bar linkage mechanism does not work. The engine is of about 1.2 to 1.8 HP only. The machine maintains row to row

spacing of 28 cm to 30 cm and plant spacing of 14 cm to 16 cm only. The planting capacity of the machine is about 0.05 to 0.1 hectare per hour.

### **Calibration of seed drill**

The procedure of testing the seed drill for correct seed rate is called calibration of seed drill. It is necessary to calibrate the seed drill before putting it in actual use to find the desired seed rate. It is done to get the pre determined seed rate of the machine. The following steps are followed for calibration of seed drill.

#### **Procedure:**

- i. Determine the nominal width (W) of seed drill

$$W = M \times S,$$

Where,

M = Number of furrow openers, and S = Spacing between the openers, m

- ii. Find the length of the strip (L) having nominal width (W)

$$\text{Necessary to cover} = 1/25 \text{ ha } (1/25 \times 10000\text{m}^2) = 400\text{m}^2$$

$$L \times W = 400 \text{ m}^2$$

Therefore,  $L = 400/W$

- iii. Determine the number of revolutions (N) of the ground wheel of the seed drill required to cover the length of the strip (L)

$$L = n \times D \times N = 400/W$$

$$N = [400/(n \times D \times W)], \text{ RPM}$$

- iv. Jack the seed drill so that the ground wheels turn freely. Make a mark on the drive wheel and a corresponding mark at a convenient place on the body of the drill to help in counting the revolutions of the ground wheel
- v. Fill the selected seed in the seed hopper. Place a container under each boot for collecting the seeds dropped from the hopper
- vi. Set the seed rate control adjustment for maximum position and mark this position on the control for reference
- vii. Engage the clutch and rotate the ground wheel for N, RPM
- viii. Weigh the quantity of seed collected in the container and record the observation.
- ix. Calculate the seed rate (kg/ha) by multiplying the rate obtained by 25 in previous step.

- x. If the calculated seed rate is higher or lower than the desired rate of selected crop, repeat the process by adjusting the seed rate control adjustment till the desired seed rate is obtained.

### Example 1

A 8-15 cm seed drill has a wheel of 50 cm diameter. The wheel shaft carries a 7 teeth sprocket which drives a 12 teeth sprocket on a counter shaft. Another 7 teeth sprocket on the counter shaft drives a 12 teeth sprocket on a shaft carrying a seed plate with 4 cells on its periphery for dropping of single seed per cell.

- a) Calculate the total number of droppings along one row in 10 minutes if the tractor pulls the drill at 6.5 km/h.
- b) Determine the horse power required to pull the planter when the cross-section of the furrow is 8 cm x 7.5 cm and soil resistance is 0.8 kgf / cm<sup>2</sup>.

### Solution

No. of rev. of plate to drop one seed,  $N_p = (1 \text{ rev}) / (4 \text{ cells}) = (1/4) \text{ rev/cell}$

Speed ratio,  $N_g / N_p = \text{Product of teeth on driven} / \text{Product of teeth on driver}$

$$N_g / N_p = (12 \times 12) / (7 \times 7)$$

No of rev. of ground wheel to drop one seed,  $N_g = [(12 \times 12) / (7 \times 7)] \times N_p$

$$= [(12 \times 12) / (7 \times 7)] \times 1/4 \text{ rev/cell}$$

$$= 0.7347 \text{ rev/cell} = 0.7347 \text{ rev/seed}$$

Distance covered by ground wheel in  $N_g$  revolutions =  $3.14 \times D_g \times N_g$

$$= 3.14159 \times 0.5 \text{ m / rev} \times 0.7347 \text{ rev/seed}$$

$$= 1.154 \text{ m/ seed}$$

The spacing of seed in row is the same as the distance covered by ground wheel in  $N_g$  revolutions = 1.154 m / seed

Distance traveled in 10 minutes = velocity x time

$$= [(6.5 \text{ km / hour}) \times 1000 \text{ m / km}] \times \text{hour} / 60 \text{ minutes}] \times 10 \text{ minutes} = 1083.33 \text{ m}$$

No. of seeds dropping along one row in 10 minutes =  $1083.33 \text{ m} / (1.154 \text{ m/seed})$

$$= 938.76 \text{ seeds} = 939 \text{ seeds} \quad \text{Ans.}$$

b) Area of cross-section = 8 cm x 7.5 cm = 60 cm<sup>2</sup>

Total draft  $D = [(0.8 \text{ kgf/ cm}^2) / \text{furrow}] \times 60 \text{ cm}^2 \times 15 \text{ furrows} = 720 \text{ kgf}$

Horse Power =  $[\text{draft (kgf)} \times \text{speed (m/min)}] / 4500$

$$= [720 \text{ kgf} \times 6.5 \text{ km/hour} \times 1000 \text{ m} \times \text{hour}] / [60 \text{ min} \times \text{km} \times 4500] = 17.33 \text{ hp} \quad \text{Ans.}$$

**Example 2**

The seed rate of a 10-20 cm seed drill was kept at 60 kg per hectare. The seed drill was jacked up to collect the seed for definite number of revolutions of the ground wheel. If the radius of the wheel is 25 cm and wheel slippage in the field is 15 %, then

- Calculate the speed of travel for wheel speed of 75 rpm.
- What would be the rpm of wheel to cover 1/8 hectare.
- What would be correction factor to multiply the indicated value, if half of the grain drill drops 26 kg for the number of revolutions indicated in (b).

**Solution:** Given that

$$W = 10 \text{ cm} \times 20 = 200 \text{ cm} = 2.00 \text{ m}$$

$$\text{Seed rate} = 60 \text{ kg/ha}$$

$$\text{Diameter of ground wheel, } D_g = 2 \times 25 = 50 \text{ cm} = 0.50 \text{ m}$$

$$\text{Circumference of ground wheel} = 3.14 \times D_g = 3.14 \times 0.5 \text{ m} = 1.57 \text{ m}$$

$$\text{Theoretical distance traveled without wheel slippage} = 3.14159 \times D_g \times N_g$$

$$N_g = \text{revolutions per minute of ground wheel}$$

$$\text{Actual speed at } N_g \text{ rev/min} = 3.14159 \times D_g \times N_g \times 85/100$$

$$\begin{aligned} \text{Actual speed at 75 rpm} &= (3.14159 \times 0.5 \text{ m / rev}) \times (75 \text{ rev/min}) \\ &\times (60 \text{ min / h}) \times \text{km}/1000 \text{ m} \times 85/100 = 6.00 \text{ km / h} \end{aligned}$$

$$\text{No. of revolutions without skid of the wheel to cover 1/8 ha} =$$

$$= (10000 \text{ m}^2 \times 1/8) / (2 \text{ m} \times 1.57 \text{ m/rev}) = 398 \text{ rev}$$

$$\text{Actual speed in field} = .85 \times 398 = 338.3 \text{ rev}$$

$$\begin{aligned} \text{Area covered by half of the grain drill} &= 1/2 \times [(2 \text{ m} \times 1.57 \text{ m}) / \text{rev}] \times 338.3 \text{ rev} = 531 \text{ m}^2 \\ &= 531 \text{ m}^2 \times \text{ha} / 10000 \text{ m}^2 = .0531 \text{ ha} \end{aligned}$$

$$\text{Seed rate} = 2.6 \text{ kg} / 0.0531 \text{ ha} = 48.95 \text{ kg/ha}$$

$$\text{Correction factor} = (60 - 48.96)/60 = 0.184 = 18.40 \%$$

**Single Seed Metering Devices**

The horizontal seed plate planter is the most commonly used equipment as a precision drill. The plate has cells on its periphery to accept single seeds. Seeds enter the cell as the plate is rotated in the bottom of seed hopper. Two types of hopper bottoms namely edge-cell, edge-drop plates and plates with round and oval holes instead of edge cells are commonly used. The edge-cell edge-drop plates are suitable for planting relatively large, flat seeds like corn. Plates with round

and oval holes instead of edge cells are used interchangeably for drilling or hill dropping seeds of various row crops. In order to meet the requirements of many types, sizes and spacing of seeds a large selection of plates is necessary.

Seeds enter the cells when the plate is rotated in the bottom of seed hopper. A spring-loaded cutoff device installed on the top of plate removes excess seeds as the cells move beneath it. As each cell passes over the seed tube, a spring-loaded knockout device forces the seed into the drop tube. Uniformity of seeds is essential to ensure that only one seed would fit into each cell. Seeds that are naturally non-uniform, such as corn kernels, are to be graded into uniform lots prior to planting. In order to match various sizes and shapes of seeds, replaceable seed plates are available.

Inclined plate metering devices are also used for metering single seed. These devices have cups on the periphery which pass through a seed reservoir fed under a baffle from the hopper. As it passes through the seed reservoir, the cup or cell lifts the seed to top of the plate travel and drop them into the seed tube. Due to absence of cutoff device, the seeds are handled more gently compared with horizontal plate units.

Plateless planters, generally called as finger pickup planters, are used for planting single seed such as corn kernels. The metering unit contains twelve spring loaded fingers which are mounted on a vertical disk that rotates in a seed hopper. The finger rides on a stationary disk which is in concentric with the rotating disk. By passing through the bottom of the hopper, each finger picks up one or more seeds. After this the finger passes over an indentation in the stationary disk, causing it to grip one seed while any others fall back into the seed hopper. With further movement, the finger passes across an opening in the stationary disk and the seed is ejected into the seed placement belt for transport to the seed tube. The whole metering unit is ground driven to maintain controlled spacing of the seeds along the rows.

Vertical-rotor metering devices are employed for precision planting of vegetables. Seed tube is not generally attached with the planter and the rotor is placed as low as possible and discharges the seed directly into the furrow. In some units seed cups are fixed in the vertical rotors which move through a shallow seed reservoir, pick up single seeds, move them over the top of the circle, and drop them during the downward travel.

The latest development in the plateless planting is the air planters that are used for planting delinted cotton seed, beans and corn. A seed drum, which is ground driven, is pressurized to about 4 kpa by a pto driven fan. The drum has variable speed and the maximum speed can be 35

revolutions per minute. Seeds from a central hopper flow under gravitational force to maintain a shallow reservoir of seed in the bottom of the drum. Four six, or eight rows can be served by each drum depending upon the number of rows of perforated holes that are provided. Each hole terminates in a seed pocket at inner face of the drum. With the rotation of drum, air escapes through holes and, when seeds enter the seed pockets, differential pressure holds each seed in its pocket until drum rotation moves the seed close to a seed tube. Differential pressure in the pocket is released by blocking the holes momentarily by a row of external wheels near the seed tubes, which allows the seeds to fall into the seed tubes. Air moving through the seed tubes carries the seeds to the planting units and deposit them in the rows. For a variety of seeds, seed drums are available to suit the seed being planted.

Vacuum-disk metering is the same as metering in air planters. The pressure differential in case of vacuum disk metering is supplied by creating a vacuum on the side of the seed disk opposite the seeds. The seed from the hopper moves to seed reservoir. Seed reservoir, having vacuum created by a pump, holds the seeds in the seed cells on the rotating seed disk. The seeds then fall into the seed tube by gravity due to blockage of vacuum as the cell reach above the tube. Seed disks are available for commercial vacuum -disk planters to meter delinted cotton, bean, edible peas, soybeans, corn and sunflowers.

### Example 3

- (a) What seed spacing is required when planting corn in rows 102 cm apart if the desired plant population is 6000 plants per hectare and an average emergence of 85 % is expected?
- (b) If the edge drop seed plate has 16 cells and a diameter of 200 mm, what is the linear cell speed in meters per minute when planting at 8 km/h

### Solution (Solution using basic concepts)

- (a) Row spacing = 102 cm  
 Plant population = 6000 plants / ha  
 Emergence rate = 85 %

No. of seeds to be planted

$$\text{Per hectare} = 6000 \times 100/85 = 7059$$

$$\text{No. of rows} = (100 \times 100 \text{ cm}) / 102 \text{ cm} = 98$$

$$\text{Seeds per row} = 7059 / 98 = 72$$

$$\text{Seed spacing} = \text{length of row} / \text{no. of seeds per row}$$

$$= \text{length of hectare} / \text{no. of seeds per row}$$

$$= (100 \times 100 \text{ cm}) / 72 = 138.88 \text{ cm} = 1.388 \text{ m}$$

$$\text{Seed spacing} = 1.388 \text{ m} \quad \text{Ans.}$$

$$\text{(b) Linear distance traveled in one rev. of the seed plate} = 3.14159 \times D \text{ m}$$

$$= 3.14159 \times 0.2 \text{ m} = 0.628 \text{ m}$$

$$\text{Seed dropped in one revolution of seed plate} = 16$$

$$\text{Revolutions of seed plate in one row length} = \text{no. of seeds per row} / \text{seed dropped in one rev. of seed plate}$$

$$= 72 / 16 = 4.5 \text{ revolutions}$$

Linear distance traveled by

$$\text{Seed plate in 4.5 revolutions} = 4.5 \times 0.628 \text{ m} = 2.826 \text{ m}$$

$$\text{Time for traveling one row length (100 m)} = [(100 \text{ m} / 8 \text{ km/h}) \times (60 \text{ minute/h})] \times 100 \text{ m} = 0.75 \text{ min.}$$

$$\text{Linear speed of seed plate} = 2.826 \text{ m} / 0.75 \text{ minute} = 3.77 \text{ m/minute} \quad \text{Ans.}$$

### Solution (using mathematical expressions)

$$\text{Plant population} = 6000 \text{ plants / ha}; \quad \text{Emergence rate} = 85 \%$$

$$\text{No. of seeds to be planted, } R_{st} = 6000 \times 100/85 = 7059$$

$$\text{Row width, } w = 102 \text{ cm} = 1.02 \text{ m}$$

$$\text{Theoretical seeding rate ( seeds / ha ) } R_{st} = 10000 / ( w \times s )$$

$$\text{Seed spacing along the row, } x_s = 10000 / w R_{st}$$

$$x_s = 10000 \text{ m}^2 / 1.02 \text{ m} \times 7059 \text{ seeds} = 1.388 \text{ m/seed}$$

$$\text{Travel speed of planter, } v = 8 \text{ km/h} = 8000 \text{ m} / 60 \text{ min} = 2.2 \text{ m/s}$$

$$\text{Number of seeds delivered per revolution of the metering device} = 16 \text{ seeds / revolution}$$

$$\text{rotational speed of metering device, } n = ?$$

$$x_s = 60 v / n$$

$$n = 60 v / x_s$$

$$n \text{ ( rev/min )} = [60 \text{ s/min} \cdot 2.22 \text{ m/s}] / [1.388 \text{ m/seed} \cdot 16 \text{ seed/rev}] = 6.00 \text{ rev/min}$$

$$\text{Distance traveled by the metering device in one revolution} = 3.14159 \cdot D$$

$$= 3.14159 \cdot 0.2 \text{ m}$$

$$\text{Linear speed of metering device} = 6.00 \text{ rev/min} \cdot 0.2 \cdot 3.14159 \text{ m/rev} = 3.77 \text{ m/min}$$

## CHAPTER-15

### INTERCULTURE TOOLS AND IMPLEMENTS

The operations performed in the field after sowing but before harvesting the crop are called as intercultural operations. Interculturing is described as breaking the upper surface of soil, uprooting the weeds (unwanted plants), aerating the soil, thereby promoting the activities of microorganism and making good mulch, so that moisture inside the field is properly retained from evaporation.. These operations are accomplished by means of many tools and equipments, such as hoes, cultivators, harrows, rotary hoes etc.

#### 15.1 Hand Hoe

Hand hoe is the most popular manually operated weeding tool use in the farm. It consists of an iron blade and a wooden handle. The operator holds 30-40cm long handle and cuts the soil with the blade to a shallow depth of 2-3 cm thereby weeds are cut and soil is stirred (Figure 15.1).



**Figure 15.1 Hand Hoe**

#### 15.2 Hoe cum Rake

The hoe cum rake is multipurpose hand tool, which consists of a flat blade on one side like powrah and prongs on the other side. The blade and prongs are either made from single stock with an eye in the centre or joined to an eye by welding. A wooden handle is fitted to the eye for operation. The flat blade is used for digging and rake side for weeding and collection of weeds and trashes. The hoe cum rake is a secondary nursery bed preparation tool and is used for lighter operations.

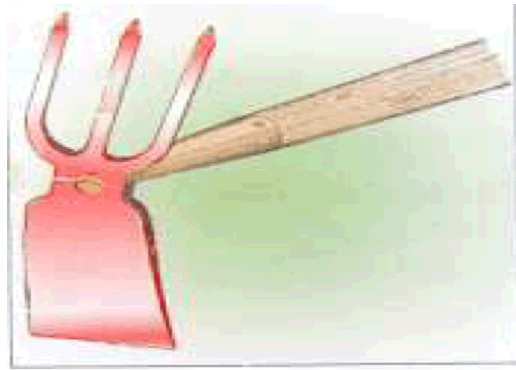

**Figure 15.2 Hoe cum rake**

### 15.3 Long Handle Weeders

Hand hoes exert greater strain on the operator because of the short handle with necessitates the operator to do weeding job in bent posture. To avoid this nowadays long handles are used in hoes and hence they are called as long handle weeders. The popular long handle weeders available are: a) star type weeder b) peg type weeder. These weeders are also called as dry land weeders since they are used in dry lands.

**a) Star type weeder :** It is suitable for weeding in dry lands. It can be used in garden lands also when the soil moisture is low (10-15 %). One limitation is that it works well in line sown crops and not in broadcasted fields. It consists of a blade for cutting the weeds, a fulcrum wheel for push-pull movement and a long handle for easy operation. Long handle reduces strain on the operator. The radial arms of the fulcrum wheel is cut in to star like projections and hence the name star type weeder. Star wheel is designed for loamy soils. The operating width of the blade is 120 mm. The coverage is 0.05 ha/day.

**b) Peg type weeder:** It is suitable for weeding in dry lands. It can be used in garden lands also when the soil moisture is low (10-15 %). One limitation is that it works well in line sown crops and not in broadcasted fields. It consists of a blade for cutting the weeds, a fulcrum wheel for push-pull movement and a long handle for easy operation. Long handle reduces strain on the operator. There are pegs welded on the periphery of the wheel hence the name peg type weeder. Peg type wheel is designed for clayey soils. The operating width of the blade is 120 mm. The coverage is 0.05 ha/day. Both star type and peg type weeders are also called as dry land weeders.

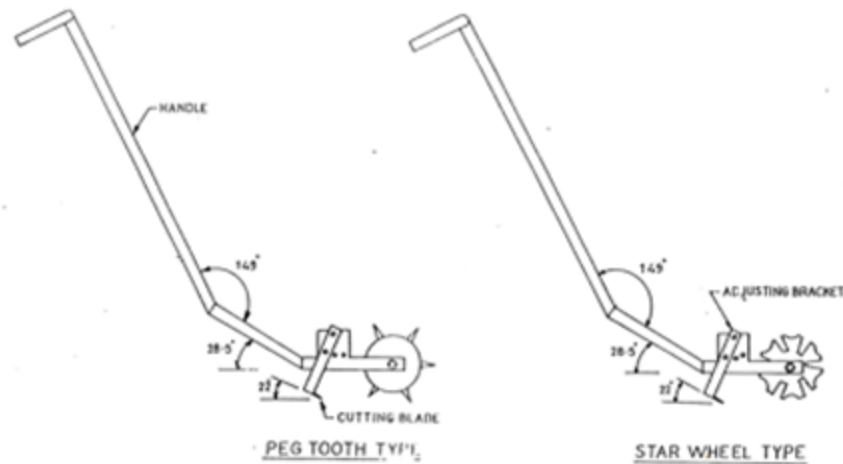

**Figure 15.3 Long Handle Weeders**

### 15.4 Cultivators

It is an implement for inter cultivation with laterally adjustable tines or discs to work between crop rows. This can be used for seed bed preparation and for sowing with seeding attachment. The tines may have provision for vertical adjustments also. The cultivator can be 1) Disc cultivator, 2) Rotary cultivator, 3) Tine cultivator.

- a) **Disc cultivator** - It is a cultivator fitted with discs.
- b) **Rotary cultivator** - It is a cultivator with tines or blades mounted on a power driven horizontal shaft.
- c) **Tine cultivator** - It is a cultivator fitted with tines having shovels. The cultivator stirs the soil, and breaks the clods. The tines fitted on the frame of the cultivator comb the soil deeply in the field. A cultivator performs functions intermediate between those of plough and the harrow. Destruction of weeds is the primary function of a cultivator. The following are a few important functions performed by a cultivator.

1. Destroy the weeds in the field.
2. Aerate the soil for proper growth of crops.
3. Conserve moisture by preparing mulch on the surface.
4. Sow seeds when it is provided with sowing attachments.
5. Prevent surface evaporation and encourage rapid infiltration of rain water into the soil.

Depending upon the type of power available for the implement, the cultivator can be classified as 1) Tractor drawn, 2) Animal drawn.

**Tractor Drawn Cultivator** - It may be 1) Trailed type 2) Mounted type.

- a) **Trailed type cultivator** - It consists of a main frame which carries a number of cross members to which tines are fitted. At the forward end of the cultivator, there is a hitch arrangement for hitching purpose. A pair of wheels is provided in the cultivator. The life is operated by both wheels simultaneously so that draft remains even and uniform. The height of the hitch is adjusted so that main frame remains horizontal over a range of depth setting. The tynes in each row are spaced widely to allow free passage of the soil and trash around them. The tines in subsequent rows are staggered so that the implement can cover the entire width nicely. The depth of working is set roughly by adjusting the tine in their clamps and the final depth control is done by a screw lever. Usually the tynes are damaged due to turning the implement at the headland without lifting it up. Care should be taken to lift the tines off the ground before turning.
- b) **Mounted Cultivator** - Tractors fitted with hydraulic lift operate the mounted type cultivators. A rectangular frame of angle iron is mounted on three point hydraulic linkage of the tractor. The cross members carry the tines in two staggered lines. For actual cutting the soil, different types of shovels and sweeps are used. A few important shovels and sweeps are a) Single point shovel b) Double point shovel c) Spear head shovel d) Sweep e) Half sweep f) Furrower. Depending upon the type of soil and crop, shovels are chosen for use on the cultivators. Usually tractor drawn cultivators are of two types, depending upon the flexibility and rigidity of tines (i) Cultivator with spring loaded tines (ii) Cultivator with rigid tynes.

**Cultivator with spring loaded Tines** - A tine hinged to the frame and loaded with a spring so that it swings back when an obstacle is encountered, is called spring loaded line. Each of the tine of this type of cultivator is provided with two heavy coil springs, pre-tensioned to ensure minimum movement except when an obstacle is encountered. The springs operate, when the points strike at roots or large stones by allowing the tines to ride over the obstruction, thus preventing damage. On passing over the obstruction, the tines are automatically reset and work continues without interruption. The tines are made of high carbon steel and are held in proper alignment on the main frame members. This type of cultivator is particularly recommended for soils which are embedded with stones or stumps. A pair of gauge wheel is provided on the cultivator for controlling the depth of operation. The cultivator may be fitted with 7, 9, 11, 13 tines or more depending upon the requirements.

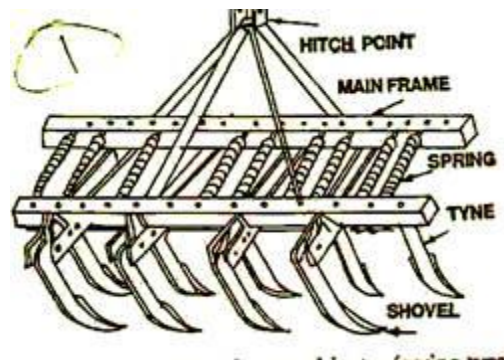

**Figure 15.4 Tractor drawn cultivator**  
[spring loaded tines]

**Cultivator with Rigid Tines** - Rigid tines of the cultivators are those tines which do not deflect during the work in the field. The tynes are bolted between angle braces, fastened to the main bars by sturdy clamps and bolts. No springs are available with these cultivators. Spacing of the tines is changed simply by slackening the bolts and sliding the braces to the desired position. Since rigid tines are mounted on the front and rear tool bars, the spacing between the tynes can be easily adjusted without getting the tines choked with stubbles of the previous crop or weed growth. A pair of gauge wheel is used for controlling the depth of operation.



**Figure 15.5 Rigid tyne cultivator**

### 15.5 Types of Shovels and Sweeps used in Tine Cultivators

#### a) Shovel type blades

- Duplex shovel or spear head shovel – for sleeve type tines
- Single point shovel – spring tooth
- Double point or reversible shovel – for spring tooth

#### b) Sweeps blades

- Full sweep

- Half sweep right
- Half sweep left
- High speed sweeps

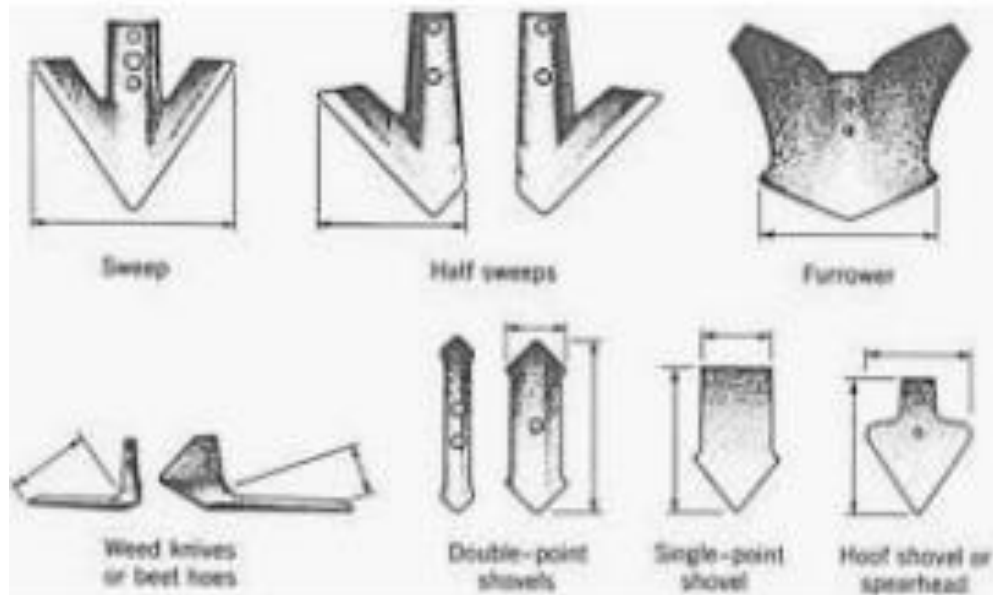

**Figure 15.6 Sweeps and shovels**

Type of soil, crops and weeds influence the use of a shovel or a sweep. Shovels and sweeps should be operated as shallow as possible to prevent pruning of roots from the plants thereby injuring the crop. Sweeps should be set almost flat. When the point is resting on the floor, or ground., the outer tip of the wing should be elevated only 3-6 mm above the floor. The shovels and sweeps should be set in between the crop rows 5 cm away and at equal distances on each side of the row to avoid any damage to the standing crop.

### **15.6 Engine Operated Weeder**

It is used for both intercultural and secondary tillage operations namely stirring the soil, uprooting the weeds, breaking clods, covering seeds etc It consists of a 3-hp engine (petrol start kerosene run), a pair of ground wheels, a cultivator frame with sweep or shovel blades, steering clutch, main clutch, handle, a tail wheel and other control levers. The engine power is transmitted to ground wheels through belt-pulley and sprocket - chain mechanisms. Ground wheels act as traction wheels and pull the cultivator when moving; The tines to be set between rows with sufficient space away from plant stems. To avoid any damage to plants. The tail wheel is provided at the rear of the cultivator frame by raising or lowering of which the

operating depth of the blades can be altered. The field capacity is 0.75 – 1.0 ha per day. The salient features of the unit are:

- Useful for weeding in row crops like tapioca, cotton, sugarcane, maize, tomato and pulses whose rows spacing is more than 60 cm
- Can be used for weeding in orchards, coconut and arecanut fields.

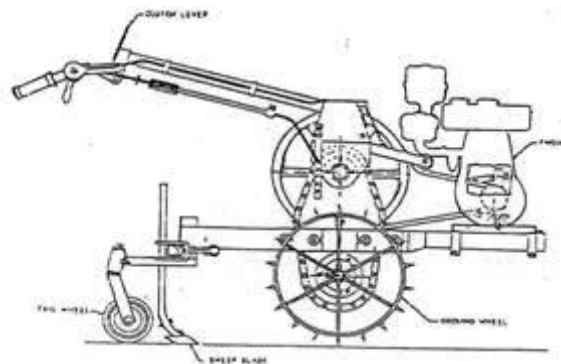

Fig.3. ENGINE OPERATED WEEDER

**Figure 15.7 Engine operated weeder**

### 15.7 Engine Operated Rotary Tiller

It is a walking type tiller used for plains and hilly regions. It is used for both intercultural and secondary tillage operations namely stirring the soil, uprooting the weeds, breaking clods, covering seeds etc It consists of a 3-hp engine (petrol start kerosene run), a rotor with L blades, rotor drive mechanism, handle and other control levers. When engine power is transmitted to rotor, the rotor rotates and till the soil. The rotor rotates in the forward direction and hence there is a forward push facilitating the forward movement of the tiller. The field capacity is 0.75 – 1.0 ha per day. The salient features of the unit are:

- Useful for weeding in row crops like tapioca, cotton, sugarcane, maize, tomato and pulses whose rows spacing is more than 60 cm
- Can be used for weeding in orchards and coconut fields.
- Suitable for hilly regions also
- Depth of cut is 8-12 cm



**Figure 15.8 Engine operated rotary tiller**

**PLANT PROTECTION EQUIPMENT***By**Engr. Prof. Dr. Muhammad Iqbal, Subject Expert**Engr. Dr. Muhammad Nadeem,, Lecturer***16.1 Introduction**

Plant protection measures have been used for successful and effective plant protection and yield increase in different parts of the world since 1867 (Hough and Freeman 1951). It has now become essential to spray the growing crops economically and profitably. Recent advances in plant breeding and genetic engineering for improving resistance of crop plants to insect, pests and diseases will undoubtedly reduce the need to rely on conventional pesticides. Nevertheless, there is still the need of applying pesticides as a relatively easy and quick method of regulation and checking the pest population. Crop losses remain severe in many areas of the world particularly in the developing countries, where irrigation allows pest to survive throughout the year (Matthews 1992).

Zalom and Fry (1992) stated that control of pests by chemical means has sharply increased since 1940s. This increase has arisen a question in people's mind about net benefit from pesticides because they pollute environment in many ways like Groundwater quality deterioration, off-site drift, and damage to non-target animal species. As urban areas expand into the rural countryside, chemical drift and water quality deterioration may become increasingly important issues. In Pakistan, the problems due to pests/insects and plant diseases convinced large number of farmers to use dusters and sprayers for application of dust or liquid fungicides, pesticides, etc. Rehman (1994) reported that in field trials conducted jointly by Agricultural Mechanization Research Institute (AMRI) and Central Cotton Research Institute (CCRI), Multan, 50 percent pesticides are wasted during application due to inefficient spraying equipment, which result in; economic loss of Rs. 3-4 billion annually, poor pest control and associated yield reduction, higher production cost due to increased number of sprays.

Once seed is sown in the field, it is not sure that it will get all the fruits from the plants. Several steps are involved from seeding to maturity of that seed. There is a danger that plant may damage at any stage due to several reasons. Pests, insects, weeds and fungi are the major threats for the growth of plants. These dangers continued till the storage of crop. On an average one

fifth of the crop yield decreased due to the above said reasons. These problems are identified by different methods. If the plant protection methods are properly implemented, then crop yield can be increased. The purpose of applying chemicals is to provide nutrients for plant growth and to control weeds, insects, and plant diseases. There are several machines equipment for the application of control measures for plant protection.

## **16.2 Classification of plant protection equipment**

Before discussing the classification of Plant protection equipment, it is necessary to know the types of agricultural chemicals.

Pesticide: chemical that kills the pests (pest may be defined as weeds, fungi, insects, etc.).

Herbicide: chemical that kills the weeds.

Fungicide: chemicals that kills the fungus.

Fertilizer: chemical that provides the crop nutrients.

Plant protection equipment may be classified according to solid and liquid form of chemicals

1. Solid application (Granular or dust)
2. Liquid Application (Liquid application)

### **1. Solid chemical application**

Solid chemicals include fertilizer, herbicides and pesticides Chemicals applied in solid forms are of normally two types one is granular and second is in the form of dust. For dry powder chemical application air is used as carrier and the machines used to apply this powder is called duster.

#### **Benefits of Solid chemical application**

1. It eliminates the need to haul water and mixing required with liquid chemicals.
2. Chemical drift is not a great problem.
3. The application equipment is less expensive and more durable since no mixing, no pumping and agitation is involved.
4. Granules are generally safer to use than liquid formulations.

#### **Drawbacks of Solid chemical application**

1. More expensive than liquid chemicals.
2. Poor metering characteristics.
3. Uniform distribution is a problem.
4. Granular pesticides have to be kept in a dry place and are bulkier to store and transport.

## **2. Liquid chemical Application**

Liquid chemicals include fertilizer, herbicides, pesticides, etc. Chemicals applied in liquid forms are mixed with water in a proper recommended ratio prior their application. Liquid chemical application takes place in form of spray droplets. The machine used to apply this liquid chemical is called sprayer.

### **Benefits of Liquid chemical application**

1. Less cost than Solid chemicals.
2. Good metering characteristics.
3. Uniform distribution.

### **Drawbacks of Liquid chemical application**

1. It needs to haul water and mixing is required.
2. Chemical drift is a great problem.
3. The application equipment is more expensive as mixing, pumping and agitation is involved.

## **16.3 Methods and Equipment**

There is different equipment used for application of solid and liquid chemicals. Granular fertilizer may be spread uniformly over the entire field, called broadcast application or applied in narrow rows called the banded application. The liquid chemicals are being applied by using the sprayers. The chemical may be in the form of powder or granular, it is mixed with clean water. Most of the chemicals are in liquid form.

### **1) Equipment for dry chemicals**

Granular fertilizer may be spread uniformly over the entire field, called broadcast application or applied in narrow rows called the banded application. Solid chemical applicators may be classified as

**Drop type applicator for banded application** - Metering device is used to control the discharge of chemicals that is dropped through a tube and is spread in a wide band by a diffuser. Some machines have furrow openers to place the material below the surface (Figure 16.1). This tractor mounted equipment

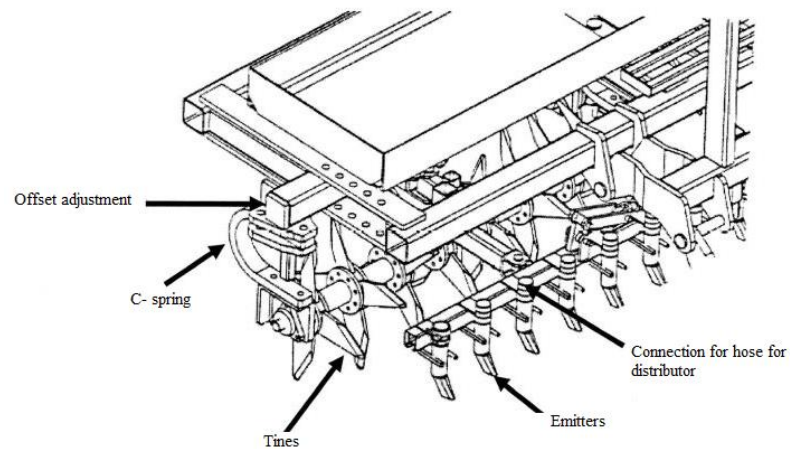

Fig. 16.1 Tractor mounted drop type applicator for banded application

Source: Srivastava et al., (1993)

**Rotary spreader** - These have one or two rotating discs with multiple vanes to impart energy to the granular fertilizer and are suited for broad casting. The material is metered into the disc and is thrown wide enough due to the centrifugal force (Figure 16.2). This is tractor mounted equipment.

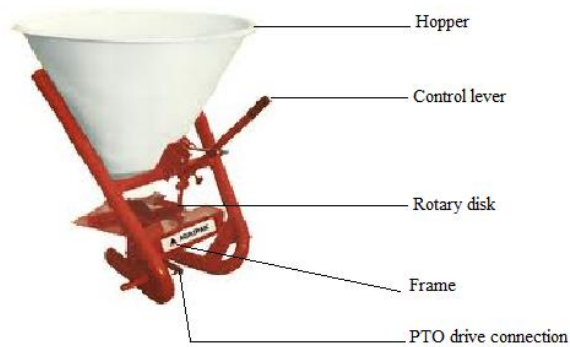

Fig. 16.2 Tractor mounted Rotary spreader

Source: Srivastava et al., (1993)

**Pneumatic applicator** - These have a centrally located hopper from which granular fertilizer/chemicals are metered, delivered by air through tubes across the width of machine and spread by being impinged onto deflector plates. These applicators allow central tank filling, easier installation on tillage implements with improved distribution. These can be used for either broadcast or band application (Figure 16.3).

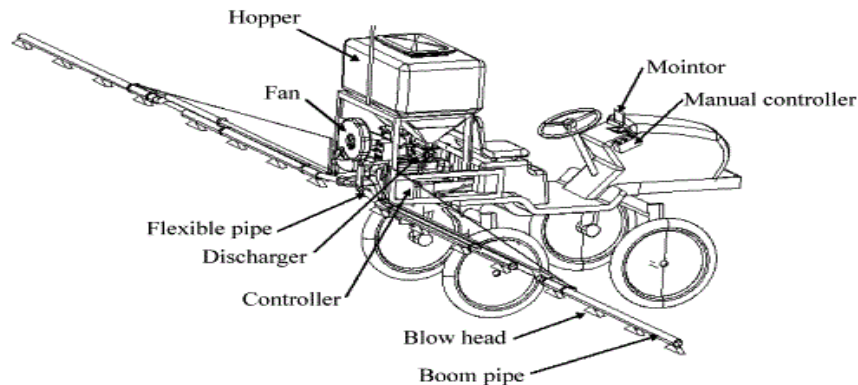

Fig. 16.3 Pneumatic applicator

**Duster** - The application of chemical to crop, insect, and other surface in the form of a fine powder is known as dusting and the machine is called a duster. Different dusters have following different components.

1. Hopper: Used to store the powder chemical.
2. Agitator: Used to prevent the powder to be converted into cake form.
3. Metering mechanism: It is usually an adjustable orifice with gate to control the discharge.
4. Delivery blower: This is used to deliver the powder to the target.

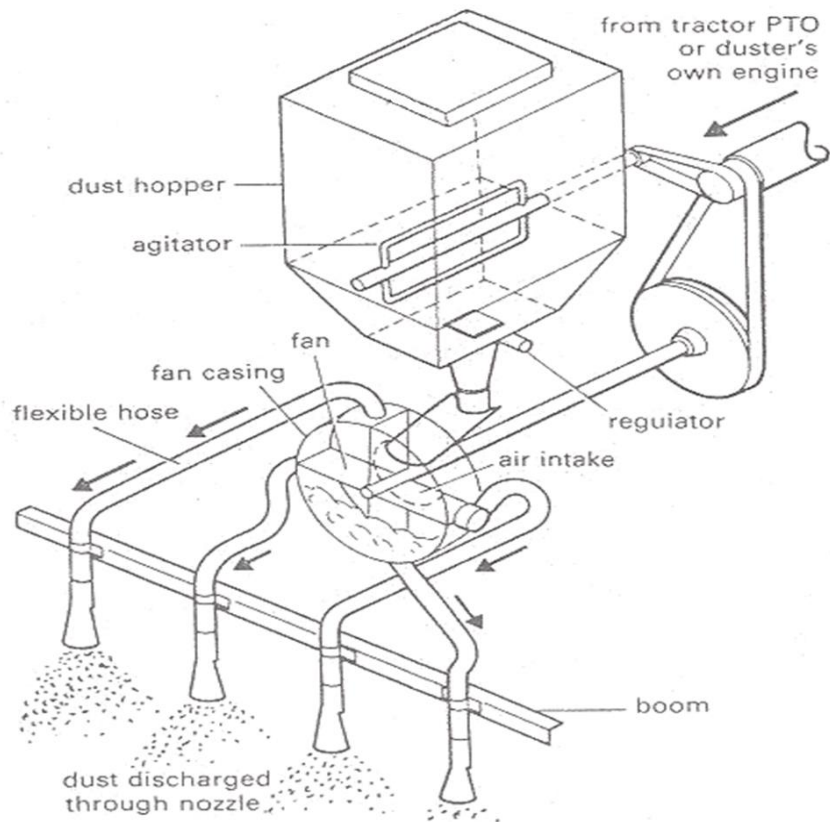

Fig. 16.4 Schematic view of main components of duster

Source: Srivastava et al., (1993)

The filler materials used for dust application are natural powders like talc, talk and chalk, talc and kaolin, road dust and others. For ground dusting, best particle size is 15 to 25 microns while, for aerial dusting, it is 25 to 40 microns. Dusting is much simpler method of chemical application than spraying. In sprayers one has to prepare solution of chemicals.

It is best suited to wet the dry dust with water or mineral oils to increase the adherence of particles to the surface of plant leaves, at the exit of the dusting nozzles. This technique helps to economise a large amount of chemicals. The consumption of water, in such cases is about 20-50 % of the dry weight of the material.

The dusting process is far simpler than spraying since it eliminates the necessity of preparing the solution. The efficiency of operation is also much greater. However, wind drift and air currents have an adverse effect on the quality of dusting. Furthermore, the quantity of chemical required for dusting is several times greater than that of spraying.

## 2) Equipment for Liquid Chemicals

The liquid chemicals are being applied by using the sprayers. There are different types of sprayers.

1. Manual operated sprayers also called knapsack sprayer
2. Carried manually but power operated
3. Tractor operated or boom sprayers

The sprayers basically apply the liquid chemicals including pesticides, herbicides, fungicides and fertilizer, etc. The chemical may be in the form of powder or granular, it is mixed with clean water. Most of the chemicals are in liquid form. Generally, the chemicals, when mixed can form one of the following.

1. Solution: In solution the chemical is completely dissolved in water.
2. Suspension: In suspension the chemical is floating on the surface of water that need continuous agitation.
3. Emulsion: In emulsion the chemical is dispersed in the water but does not actually dissolve.

### Manual operated sprayers

1. This sprayer is carried by the operator and operated by hands or feet. The feet operated has a paddle to actuate the pump. The pedal is pushed in the same manner as the machine is operated by hand lever.
2. The machine which is carried on the shoulders of a man is known as knapsack sprayers. It is ideal for small nurseries, rose plants, kitchen gardening and spraying wetttable insecticides and fungicides (Figure. 16.5)

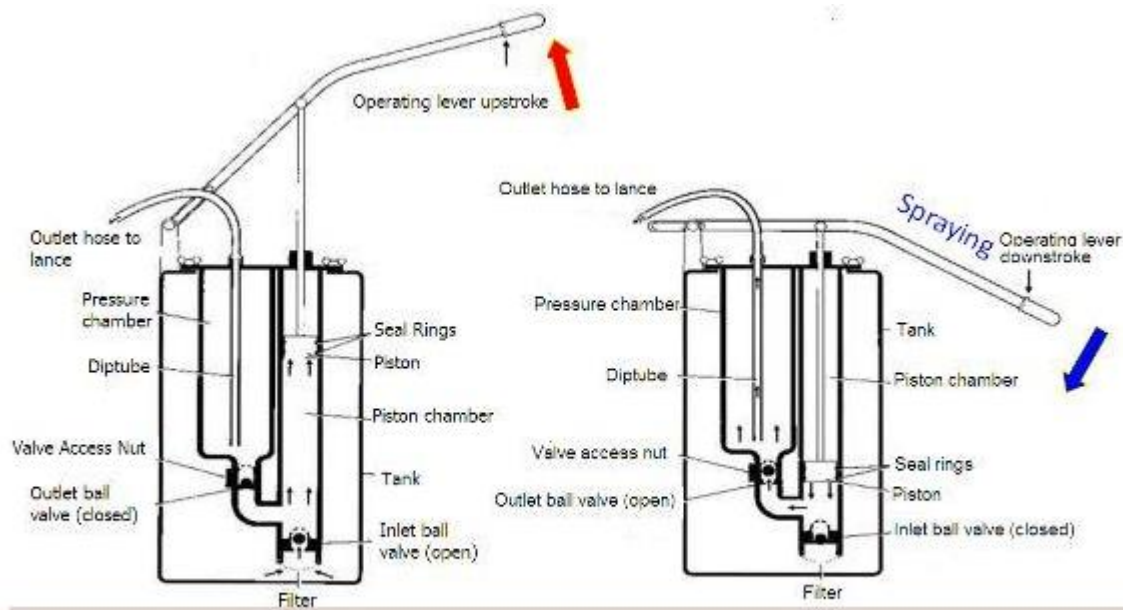

Lever operated knapsack sprayer: cross sectional drawing showing operation of an over-arm lever sprayer with piston pump.

Fig. 16.5 Knapsack sprayer components

Source: <http://www.stewardshipcommunity.com/best-spraying-practices/portable-spraying-equipment.html>

### Carried manually and power operated

These machines are similar to the manual operated sprayers. These machines are carried on shoulders but operated with the help of an engine which is attached with this machine. This engine provides power and generates the mist of liquid chemical at the tip of nozzles (Figure. 16.6). These machines are suitable for spraying in orchards, vegetables fields and tall crops.

- Weight of machine = 11-15 kg
- Power requirement = 1.2-1.5 hp
- Field capacity = 3 ha/h
- Vertical Range = 6-8 m



Fig. 16.6 Carried manual power operated sprayer

Source: Annai Engineering Enterprises, Kavundam palayam, Coimbatore, Tamil Nadu

It is a durable and precision range of Power Sprayer used in diverse agricultural purposes. It is portable, compact and have an excellent fuel efficiency.

#### **Tractor operated boom sprayers and their principal parts**

There are two types of boom sprayers, conventional sprayers and drop pipe boom sprayers. The principal parts of a boom sprayer are: Tank, Sight gauge, Agitation device, Strainer, Pump, Nozzles, Hoses and Lines, Control valve, Pressure gauge, Boom arm, and Sprayer Stand (Figure 16.7).

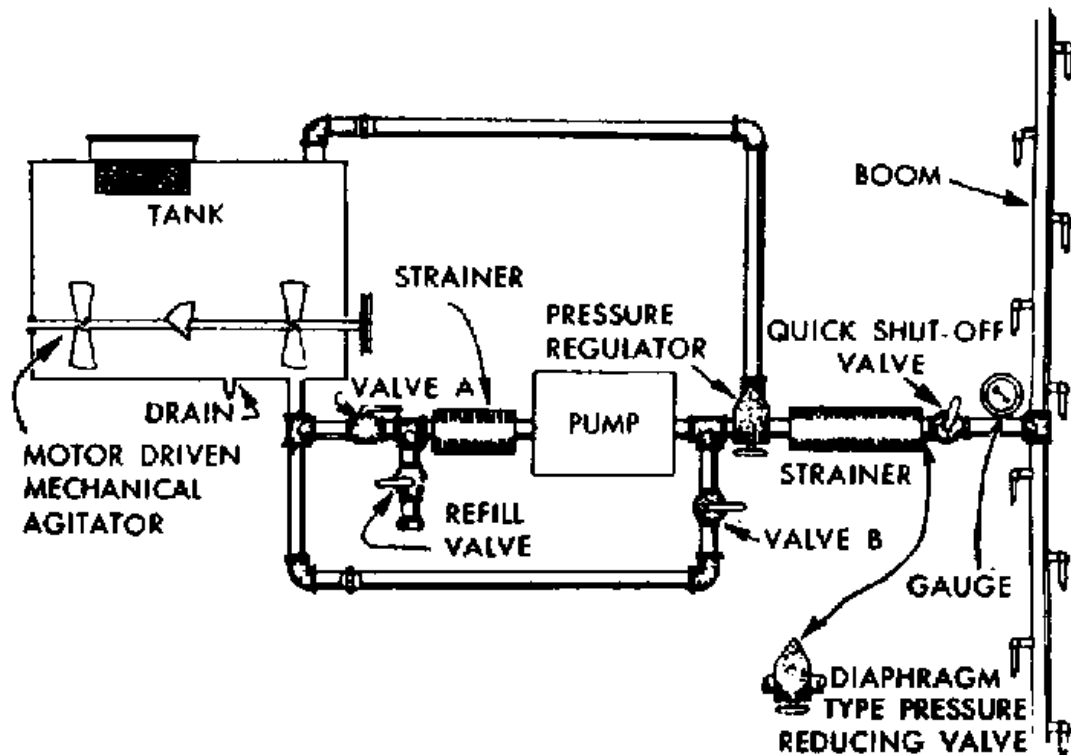

Fig. 16.7 Schematic diagram of boom sprayer components

Source: <https://www.google.com.pk/search?q=parts> of conventional tractor boom sprayer

**1. Tank-** Tank is a main source of storing the mixture of water and chemical. It should have sufficient capacity. It is available in many shapes such as spherical, rectangular, elliptical and cylindrical. The tank should be provided with a large enough drain hole or plug at the lowest point for complete drainage and cleaning purposes. On the sprayers mostly plastic or steel tanks of variable capacity are being used. Plastic tanks are relatively inexpensive, weather resistant and are not damaged in sunlight. The plastic tanks are irreparable and also not good for chemicals containing nitrogen or phosphate solution due to their reaction-ability. Both the plastic and steel tanks are corrosion resistant. Steel tanks are relatively expensive. These tanks may have capacity of holding mixture of water and chemicals 450- 500 liters.

**2. Sight Gauge -** Sight gauge indicates the level of liquid in the tank. A transparent and flexible rubber pipe has normally been used as sight gauge to indicate the level of chemical in the tank.

**3. Agitation Device -** Agitation is required in the spray tank to ensure that a pesticide is properly mixed before spraying commences and then to maintain the correct mixture throughout the spraying period. Agitation is especially important when suspensions are applied. The flow necessary for efficient mixing/agitation depends on the chemical composition of the substance

to be sprayed. For example, wettable powder requires more agitation than emulsifiable to keep them in suspension. There are three types of agitation systems in the tank.

1. Mechanical agitation (paddle or propeller on rotating shaft)
2. Hydraulic agitation (portion of flow is returned by the pump to tank for agitation)
3. Jet agitation (a part of flow is returned from the bottom of the tank in the form of jet)

**4. Strainers** - Line and nozzle strainers are very important parts of the spraying system. They are used as filtering system to avoid the clogging of other parts. Properly sized and placed strainers prevent clogging of nozzles and the uniformity problems associated with them. Plumbing diagram for a roller pump (positive displacement pump) have been presented in Figure 16.8.

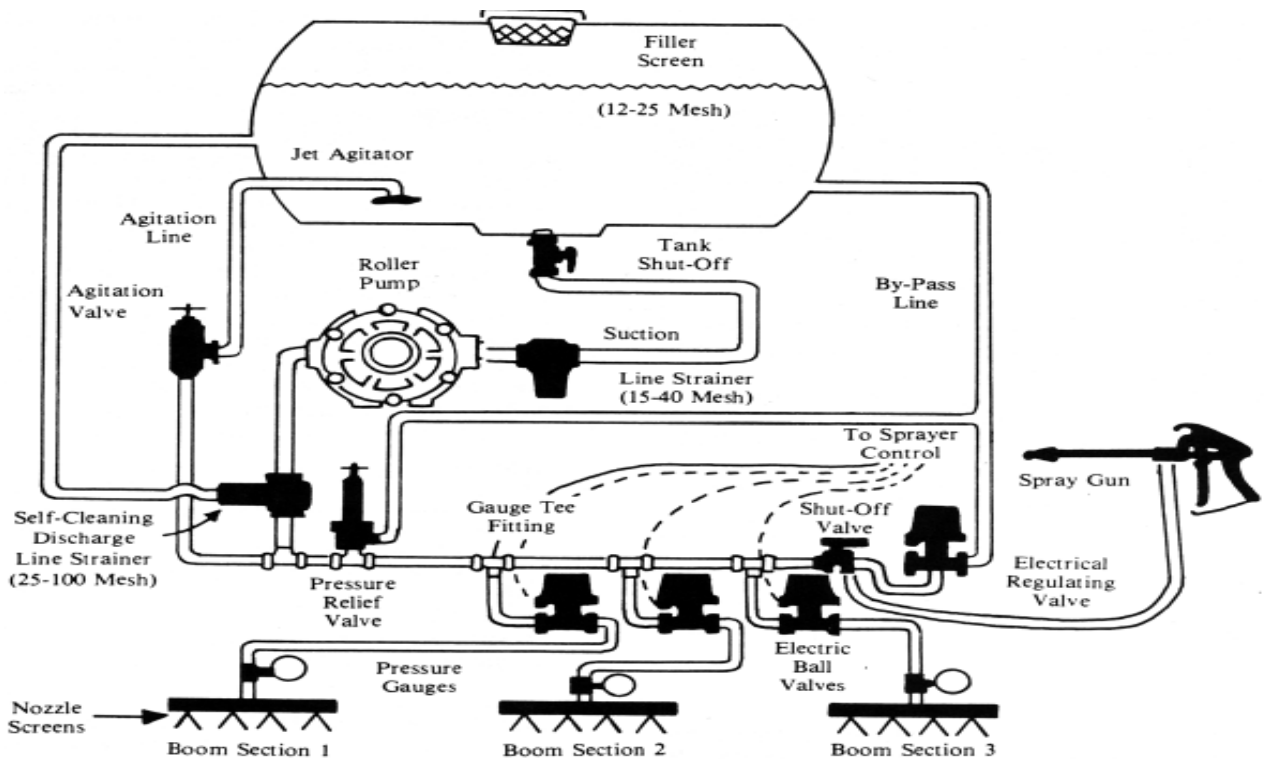

Figure 16.8 Plumbing diagram for a roller pump (positive displacement pump).

Source: Weaver, M. and R. Grisso. Publication 442-452. Biological Systems Engineering Department, Virginia Tech

**5. Pump-** It is an important part of sprayer. The function of the pump is to create flow. A suitable pump must deliver adequate flow and pressure, and it should handle the desired chemicals without rapid corrosion and wear. Different types of pumps are used on tractor mounted sprayers like diaphragm, piston, centrifugal, turbine and roller vane. Selection of pump will depend on the total volume of the liquid and pressure required to feed the nozzles and

agitate liquid in the tank. Pumps are generally divided into two categories positive displacement pumps and non-positive displacement pumps. Positive displacement pumps include piston pumps, diaphragm pumps and roller pumps (at low operating pressures). Non-positive displacement pumps depend on external restrictions like fluid viscosity and downstream pressure. Pumps used in spraying machinery are shown in Figure 16.9 and their characteristics are presented in Table 16.1.



a) Centrifugal Pump



b) Piston Pump

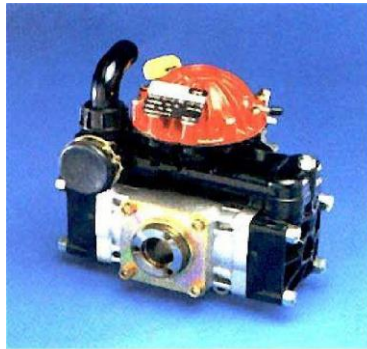

c) Diaphragm Pump



d) Roller Pump

Figure 16.9 Pumps for Applying Crop Protection Products

Source: *Wolf (2010)*

Table 16.1 Different types of pumps with their characteristics

Parameter	Gear	Rotary	Diaphragm	Piston	C/fugal	Roller vane
<b>Relative cost</b>	Low	Low	High	High	Medium	Low
<b>Durability</b>	Short	Short	Long	Long	Long	Short
<b>Max. pressure (bar)</b> 1-bar=100 kPa =14.5 psi	6	5	60	70	5	20
<b>Max. flow rate (l/min)</b>	200	75	100	100	500	150
<b>Speed range (rpm)</b>	200-500	200-500	200-1200	600-1800	2000-4500	300-1000
<b>Advantage</b>	Low cost	Low cost repairable	Wear resistant	Wear resistant self Priming	High output	Easily repairable
<b>Disadvantage</b>	Short life Not Repairable	Short life	Low out put needs compression chamber	High cost needs air Chamber	Low pressure requires priming and high speed	Short life

Source: Wolf (2010) and Rehman (1994)

**6. Nozzles-** Nozzles are the most important component of the sprayer it meters the right amount of liquid and control the uniformity of sprayer over the entire width of the boom sprayer. The function of nozzles is to accelerate and disintegrate the flow of spray liquid passing through it into droplets to form a spray. The nozzle flow rate depends on the size of the nozzle orifice and pressure. Spraying nozzles are made from different types of materials like Aluminum, brass, stainless steel, harden stainless steel, ceramic and nylon. The criteria for selection of suitable nozzle are based on the pesticide being applied and surface being treated. Most ranges of sprayer nozzles are available in two or three particular angles, 65°, 80° and 110° but certain nozzles are available in narrow or wider than these standard angles. The narrow spray angle is chosen when penetration of taller crop is required. Hanna (1985) stated that selection of proper nozzle for each type of spray application is important. There are different kinds of nozzles with different ranges available to provide differences in throughput, spray angle, and pattern.

**1) Regular Flat-Fan Nozzles** - Regular flat-fan nozzles are used for broadcast application of

herbicides and fertilizers. For insecticides and fungicides requiring complete foliar coverage, some other type of nozzle is used. Spray droplets from a flat-fan nozzle form a fan shape as they leave the nozzle and deposit an elliptical pattern on the ground. These nozzles produce tapered edge spray patterns, resulting in reduced volumes at both edges. Therefore, adjacent nozzle patterns must overlap for uniform coverage. Boom height is adjusted, so that adjacent nozzle patterns overlap 40 to 50 percent of the nozzle spacing.

**2) Even Flat-Fan Nozzles-** Even flat-fan nozzles are similar to regular flat-fan nozzles except the edges of the spray pattern have as much spray volume as the center of the pattern. Coverage with even flat-fan nozzles is more uniform than that of the regular flat-fan nozzles. Use even flat-fan nozzles only for banding pesticides over the row at 103-306 kPa (15 to 30 psi). Even flat-fan nozzles are frequently used with planting equipment. Generally, these nozzles come with 80- or 95 degrees spray angles.

**3) Flooding- Fan Nozzles-** Flooding-fan nozzles work well for application of herbicides and chemical-fertilizer mixtures. They are also used for applying post-emergence chemicals between rows of maturing crops. They deliver a wide (up to  $160^{\circ}$  angle) flat spray with large droplets. The wide spray angle allows wider nozzle spacing and lower boom heights for broadcast spraying. These nozzles operate at low pressures than flat-fan nozzles so resulting less drift. They are most effective in reducing drift when operated within a pressure range of 8 to 172 kPa (25psi). One disadvantage of the flooding-fan nozzle is that its application rate across the boom is not as uniform as with the regular flat-fan nozzle. The flooding-fan nozzle has a high application rate along the edges of the pattern.

**4) Cone Nozzles-** Cone nozzles are used for application of insecticides, fungicides, or growth regulators to field crops where penetration and complete coverage of foliage is needed. There are variety of nozzles producing a conical spray pattern. Some nozzles produce a hollow cone pattern, where the liquid is concentrated on the outside of the cone pattern. These nozzles operate best at about 80 psi, but the pressure may vary from 276-690 kPa(40 to 100 psi). Other cone nozzles produce a solid-cone pattern of spray. It distributes the spray droplets over the entire circle. Hollow cone nozzles are ideal for low volume applications while solid cones are ideal to apply high volumes. Spray drift with these two cone nozzles is relatively high due to the number of fine droplets produced. Extra precautionary measures are required for using these nozzles in areas where drifting is dangerous. Nozzles with their spray angle, pressure and droplet size are shown in Table 16.2.

Table 16.2 Nozzles with their spray angle, pressure and droplet size

Nozzle type	Spray angle, degree	Operating pressure (bar) 1-bar=100 kPa =14.5 psi	Droplet size (micron)	Target
<b>Hollow cone</b>	65-110	3	100-150	Foliage, cotton
<b>Solid cone</b>	25-70	3	100-200	Spot treatment
<b>Variable cone</b>	0-110	3-10	100-200	Orchards
<b>Flat fan</b>	80-110	2-3	200-250	Post emergence herbicide
<b>Flood jet</b>	90-140	1-2	>250	Pre emergence herbicide
<b>Dual fluid</b>	90-140	1-2	>250	Foliage, herbicide

Wolf (2010) and Rehman (1994)









								
	Extended Range Flat Fan	Standard Flat Fan	Drift Guard Flat Fan	Twin Flat Fan	Turbo Flood Wide Angle	Wide Angle Full Core	Flood Nozzle Wide Angle	Raindrop Hollow Cone
<b>Herbicides</b>								
Soil-incorporated Pre-emerge	Good Very Good (at low pressure)	Good	Very Good Very Good		Very Good Very Good	Very Good Very Good	Good	Good Good
Post-emerge Contact	Good	Good	Very Good	Very Good	Very Good			Good
Post-emerge Systemic	Very Good Very Good (at low pressure)	Good	Very Good		Very Good			
<b>Fungicides</b>								
Contact	Very Good	Good	Very Good		Very Good			
Systemic	Very Good Very Good (at low pressure)	Good	Very Good		Very Good			
<b>Insecticides</b>								
Contact	Good	Good	Very Good	Very Good	Very Good			
Systemic	Good Very Good (at low pressure)	Good	Very Good	Very Good	Very Good			

Figure 16.10 Types of spray nozzles

Source: [https://www.google.com.pk/search?q=types of crop nozzles spray](https://www.google.com.pk/search?q=types+of+crop+nozzles+spray)

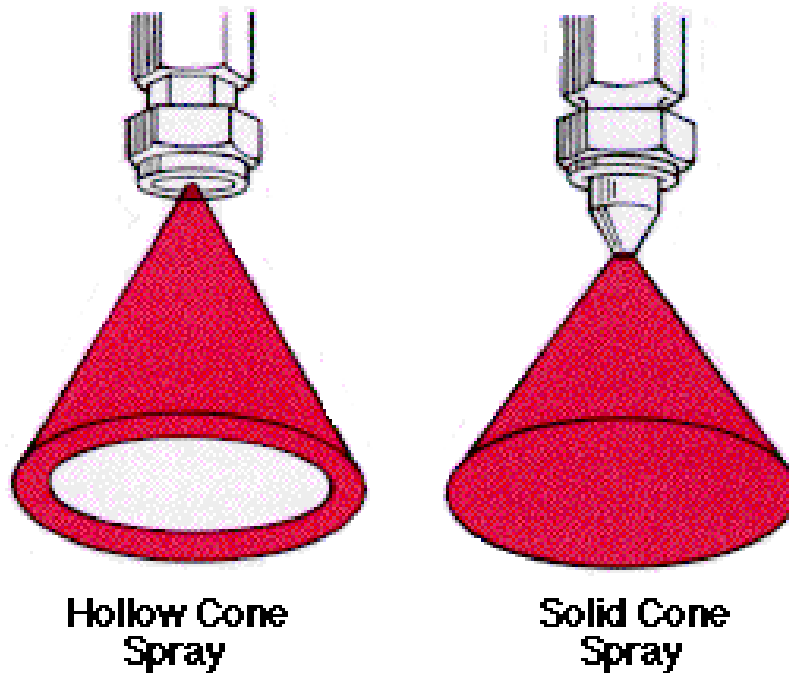

Figure 16.11 Hollow cone and solid cone nozzles

Source: <https://www.google.com.pk/search?q=types> of crop nozzles spray

**7. Hoses and lines** -The lines should be held at the center of each boom to maintain the pressure throughout the boom. Spray lines and hoses must be properly sized, depending on the inside diameter of the hose and the flow capacity of the line. Sufficient flow velocity is required so suspended particles will not settle in the lines which cause pressure drop and reduce the nozzle flow rate.

**8. Control valve** - A control valve is used to regulate the flow of liquid at various pump pressures. Liquid flow in the boom can be set in a direction to a part of boom, to all the parts of boom, or can be shut off completely by directing the flow of water back to the tank using a bypass valve. This arrangement makes possible to apply chemicals to the nozzles on the left, center or right portion of the boom or for any combination of these three sections. This is particularly important when testing field edges and part of the field is not required. The control valve has six outlets, three for boom sections, one for agitation device, one for tank filling device and one for installing glycerin filling pressure gauge 1500 kPa(15 bars).

**9. Pressure gauge** - At least one accurate pressure gauge is required on all sprayers. It should be placed near to the regulator valve so that the actual pressure in the boom line should be found. An accurate pressure gauge is very useful in identifying the working pressure of the system during operation. The scale on the gauge should be such that at normal operating

pressure the gauge is working properly. A glycerin filled pressure gauge be mounted on the control valve to monitor the pressure developed by the piston pump.

**10. Boom Arm** - This has mostly a wet boom because the liquid pipe is an integral part of arm. The boom consists of 3-7 sections. It should be made of mild steel 1025. The boom has a number of nozzles with respect to the desired nozzle to nozzle spacing.

**11. Sprayer Stand** -The sprayer stand is generally made of mild steel 1025. Strong MS angle iron are developed in to square channels to support the whole spray assembly. Both the conventional and drop pipe sprayers have been presented in Figure 16.12.

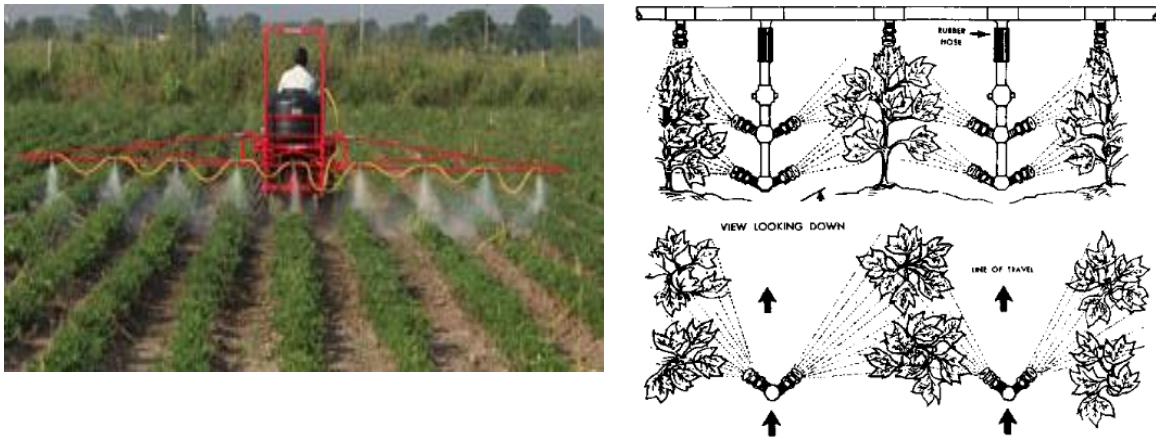

Figure 16.12 Conventional boom sprayer spraying over a row crop (LHS) and drop pipe boom sprayer spraying over and under the crop leaves (RHS)

Source: <http://www.captaintractors.com/sprayer-pump.html>

## Spray nozzle characteristics

Following are the different characteristic of a sprayer nozzle.

**1) Discharge of Nozzle**– Hanna (1985) stated that nozzle flow rate depends on the size of the nozzle opening and the pressure applied. Usually, flow rate increases with the increase in pressure. This increase, however, is not a one-to-one correspondence. In other words, doubling the pressure does not double the flow rate. The pressure must be increased by a factor of 4 to double the flow rate. Kepner et al. (1987) reported that the flow rate for a particular nozzle is about proportional to the square root of the pressure. For nozzles with geometrically similar passages, the discharge rate is about proportional to the orifice area. Because cone type, hollow cone nozzles and the smaller sizes of disk type, hollow cone nozzles have an appreciable pressure drop in the whirl devices, the flow rate increases more slowly than the orifice area if the whirl openings are not enlarged proportionately. With some nozzles the pressure drop

through the whirl device is low enough that it does not have any great effect on the flow rate. Matthews (1992) reported that the throughput for each nozzle can be determined from the output of the pump and the number of nozzles on the boom, as shown in following relationship.

$$\text{Nozzle throughput} = \text{Pump out put (liters / min)} / \text{Number of nozzles}$$

**2) Spraying Pressure of nozzle-** Reed (1984) concluded that wear rate of nozzle spray tip is significantly affected by spraying pressure. He reported that an 800 liters brass nozzle spray tip was greatly affected by spray pressure. For example, the relative wear life was five times longer at 138 kPa as compared to 414 kPa. A comparison of relative wear between 800L stainless steel and brass fan spray tips showed that stainless steel had 9.5 times longer life when the operating pressure was 138 kPa but only four times longer life when operated at 414 kPa. Matthews (1992) described that all sprayers have three characteristics in common. Spray liquid is held in a tank (spray container) from which it is forced by pumps, pressure or gravity feed system to one or more outlets called sprayer nozzles. Usually the amount of liquid sprayed is metered at the nozzle, but on some sprayers such as motorized knapsack mist blowers, the metering of liquid by means of a separate restrictor. Energy is required to break up the liquid into small droplets. Sprayer nozzles are generally categorized on the basis of the energy system used, namely hydraulic, gaseous, electrical, etc. Many hydraulic nozzles have been deigned in which liquid under pressure is forced through a small opening or orifice so that there is sufficient velocity energy to spread out the liquid, usually in a thin sheet that becomes unstable and disintegrates into droplets of different sizes. A minimum pressure is necessary to provide sufficient velocity energy to overcome the contracting forces of surfaces tension and to obtain the formation of spray pattern. The minimum pressure for most nozzles is at least one bar (14.5 psi) but usually 2-3 bar is required. An increase in pressure opens the sheet and also increases the flow rate in proportion to the square root of the pressure. Operating pressure of any type of hydraulic sprayer critically affects the nozzle's flow rate/discharge and droplet size. Too low pressure result in poor coverage and bigger droplets which are undesirable for contact action type pesticides. Too high pressure on the other hand results in too small droplets which in turn decreases terminal velocity and may result in increased hazards of excessive drift and evaporation. Therefore, the sprayer should be provided pressure gauges so that the desired pressure could be maintained (Hameed and Rehman 1996).

**3) Spray pattern of nozzles-** Thorton and Kibble (1974) have described a patternator in which the liquid monitored through a flow meter is sprayed from one, two or three nozzles onto a

channeled table and collected in a sloping section, which drains into calibrated collecting tubes at the ends of channels. Separation of channels is by means of brass knife-edge strips, below which are a series of baffles to prevent droplets bouncing from one channel to another. Spray distribution has been measured satisfactorily with a simple patternator consisting of a metal tray corrugated so that the width of each channel is 2.5 cm. The nozzle is usually mounted 45 cm above the tray. The width of each channel is 5 cm on some patternometers. Carlson et al. (1979) carried out the patternator tests to determine the uniformity of distribution across spray booms fitted with various types of nozzles. Boom height and spray pressure variations influenced the uniformity of flat fan nozzles 152.4 cm or less apart and overlapping the patterns gave 100 percent better distribution than wider spraying and /or not overlapping the patterns. Cone type nozzles such as the swirl chamber and rain drop nozzles gave uniform spray distribution only oriented at 45 degree angle and at 60 degree angle from the perpendicular direction gave more uniform distribution.

**4) Nozzle droplet size** - Spray droplet size is the most important parameter of nozzle performance. An optimum droplet size is one, which gives most effective coverage on the target with minimum contamination of the environment. Kepner et al. (1987) reported that in general, the degree of atomization depends upon the characteristics and operating conditions of the nozzle and upon the characteristics of liquid being atomized. The average droplet size from a given nozzle is decreased if either the surface tension or the density of the liquid is reduced, but it is not greatly affected by viscosity in the range from one to ten times the viscosity of water. Limited tests indicate that, within the range of conditions normally encountered with either field sprayers or high pressure orchard sprayers, the average droplet size produced by a given nozzle handling a particular fluid varies about as the inverse square root of the pressure. Fraser (1956) and Metcalf (1958) used the following formulae for calculating the mean diameter of the droplets for different types of nozzles. He mentioned the following formulae for swirl spray nozzles for small volumes, flow number up to 5, pressure up to 50 psi, spray angle up to 90 degrees and using water as a fluid.

$$\text{For water, SMD} = 437 (\text{FN} / \text{P})^{1/3} \text{ ----- } 16.1$$

Where; SMD = Surface mean diameter (microns); P = Pressure of fluid (psi)

FN = Flow rate (gallons/hr) / (Pressure (psi))<sup>1/2</sup>

For large nozzles with water for flow numbers between 10 and 500 and pressures up to 100 psi and a spray angle up to 90 degree, the following formulae was reported by Fraser (1956)

$$\text{SMD} = 119.2 \text{ FN} / \text{P} \text{ ----- } 16.2$$

For fan spray nozzles with water for a spray angle up to 120 degree and pressure up to 100 psi, the following formulae was reported:

$$\text{SMD} = 585 (\text{FN} / \text{P})^{1/3} \text{ ----- } 16.3$$

For impact nozzles with water for flow number up to 5, pressure up to 100 psi and angle between jet and impact plate of 30 degree, the following formulae was stated:

$$\text{SMD} = 1160 (\text{FN} / \text{P})^{1/5} \text{ ----- } 16.4$$

For simple jet with an orifice diameter of 2 mm, droplet size was found independent of the orifice diameter, and therefore independent also of Flow Number. The following formulae were reported in such cases:

$$\text{SMD} = 10,000 \times (1/\text{P})^{1/2} \text{ ----- } 16.5$$

Droplets according to their size and characteristics are tabulated in Table 16.3.

Table 16.3 Droplets according to their size.

<b>Droplet size</b>	<b>Spray classification</b>	<b>Target</b>	<b>Retention on target</b>	<b>Drift hazards</b>
< 25	Fine aerosol	Flying insect	Good	High
26-50	Course aerosol	Foliage insect	Good	High
51-100	Mist	Foliage	Good	High
101-200	Fine spray	Foliage	Moderate	Low
201-300	Medium spray	herbicide	Poor	Very low
> 300	Course spray	Liquid fert.	Very poor	No drift

Rehman (1994).

Sheikh and Sabir (1984) reported that the droplet size decreased linearly with pressure from 23 to 30 psi and then remained almost constant from 30 to 40 psi. The range from 30 to 40 psi may be considered optimum, beyond which the system may be rendered uneconomical, since greater pressures beyond 40 psi required sturdy equipment and accessories to with stand high pressures. Further, it may be noted that the minimum droplet size for the pressure range of 30 to 40 psi is around 170 microns, which remain within the recommendations given by many workers for insecticide application.

**5) Nozzle spray Uniformity of Coverage** - Kepner et al. (1987) reported that uniformity of spray distribution could be determined in the laboratory or in the field by means of sensitized paper or by spraying colored liquid on to plain paper. Another method for determining

uniformity of application involves spraying colored liquid onto distributed metal or glass sheets from which it can be washed and analyzed quantitatively by means of calorimetry or spectrophotometry. Uniformity of coverage on plant surfaces can be checked by adding fluorescent dyes to the spray or dust and then viewing the surfaces with a fluorescent light (ultraviolet, with filter) after dark. A permanent record can be obtained by means of ultraviolet photography.

**6) Nozzle spray swath width & spray angle** - Swath width and spray angles (angle between the outer surfaces of the sprayed liquid with respect to nozzle orifice) are the important parameters of spray nozzle performance. Wider angles of spray will require high pressure of application. Spray angle increases with the increase in pressure. Spray angle of each nozzle is calculated by measuring the effective swath width. The distance between extreme graduated cylinders collecting water is measured and the angle is calculated with the help of following equation 16.6

$$\Theta / 2 = \tan^{-1} (b / H) \dots\dots\dots 16.6$$

Where,  $\Theta$  = Cone angle     $b = 1/2$  of swath width     $H$  = height of nozzle

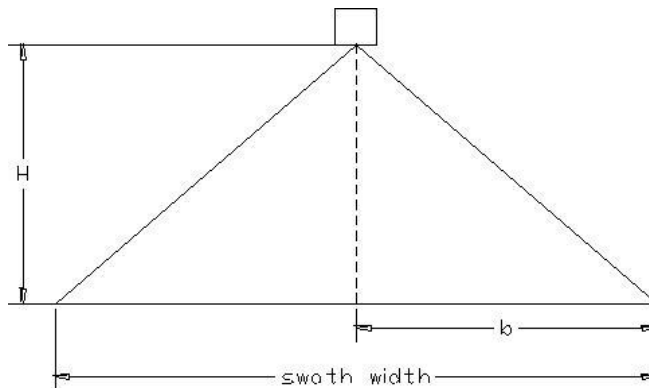

**7) Nozzle spray pressure** - Spraying pressure affects the nozzle flow rate / discharge and droplet size. Too low-pressure results in poor coverage and bigger droplets, which are undesirable for contact action type pesticides. Too high pressure on the other side results in too small droplets, which may result hazards of excessive drift and evaporation. A glycerin filled 10- bar pressure gauge be mounted on the main boom supply pipe to register the pressure. Pump is used to create the fluid pressure. A pressure regulating valve and a pressure gauge are fitted to monitor the required pressure. A fine strainer is fitted on the suction pipe of the pump to remove / prevent the foreign matter.

**8) Nozzle spray droplet size** - Droplet size is the most important parameter of nozzle performance. An optimum droplet size is one, which gives most effective coverage of the target with minimum contamination of the environment. Fraser (1956) developed a relationship for nozzle hollow cone type and for pressure from 35-1380 kPa (5 psi to 200 psi) using water as fluid (Equation 16.7).

$$\text{SMD} = 437 (\text{FN} / \text{P})^{1/3} \dots\dots\dots 16.7$$

Where,

SMD = Surface mean diameter, microns( $10^{-6}$  m)

FN = Flow number = (Discharge, gal/hr)/ (Pressure, psi)<sup>1/2</sup>

P = Pressure of fluid

**9) Nozzle spray pattern**- Spray pattern is generally the spraying trend of a specific nozzle. It helps to evaluate the fluid proportion sprayed along the swath width of a nozzle. In determining spray pattern, nozzle is operated from a known height at a specific pressure. The fluid from nozzle hitting the corrugated sheet of sprayer tester moves into the V-channels on the corrugated sheet and collected in the graduated cylinders (Figure 16.13). From these cylinders, volume of fluid collected is measured. A histogram between discharge of each nozzle & cylinder distance can plotted to see the spray pattern of nozzle. Spray patterns of different nozzles have been presented in Figure 16.13.



Figure 16.13 Boom sprayer test bench

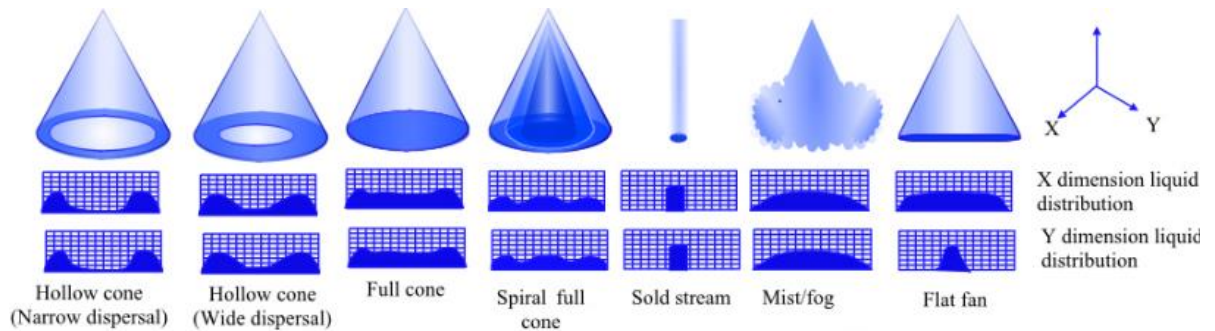

Figure 16.14 Spray patterns of different nozzles

Source: [www.google.com.pk/search?q=the spray pattern of a nozzle](http://www.google.com.pk/search?q=the+spray+pattern+of+a+nozzle)

## 16.4 Calibration of spraying machines

The manufacturers normally provide different charts which show the expected application rate of sprayer at different pressure, using different types of nozzles and at different speed of tractors. Calibration is a process to make the discharge close to the expected value. Discharge variations are due to nozzles wear or other factors. It is essential, to calibrate the chemical applicators before use to ensure the expected rate of application.

### 1) Calibration of rotary spreader

The objective of calibration of rotary spreader is to obtain the uniform distribution or desired application rate (kg/ha) of granular chemicals throughout the field. Establishment of swath width is much important as this affect the spread pattern. The pattern results in uniform coverage if proper overlap is maintained.

In most of the cases manufacturers provide manual with set of instructions to establish the swath width and spread pattern. For calibration of rotary spreader following steps should be followed.

1. Mark an area in the field let 9-15 m of width and 75 m length (Figure 16.14)
2. Spray material collection tray be placed along a straight line at  $90^{\circ}$  movement of spreader at let 1 to 1.5 m apart from center to center of pan
3. Run the spreader at least 30 m before it reaches the collection trays and continue spreading at least 45 m after.
4. Perform the trial for known application rate of granular chemical
5. Remember to move the tractor in opposite direction of wind.
6. Collect the chemical collected in the pans and weigh them. Also calculate the area of all the pans.

7. Convert the chemical application rate as kg/ha.
8. Draw bar graphs of the application rate (kg/ha) against the collection tray spacing (m).
9. Calculate the effective swath width by locating the point in either side of the center where the application rate is one half. The distance between these points will be the effective swath width
10. Repeat the trial at least three times and compare the average spread pattern with manufacturer's specifications (Figure 16.15).

Fig.16.14  
pattern test area  
calibration of a  
spreader

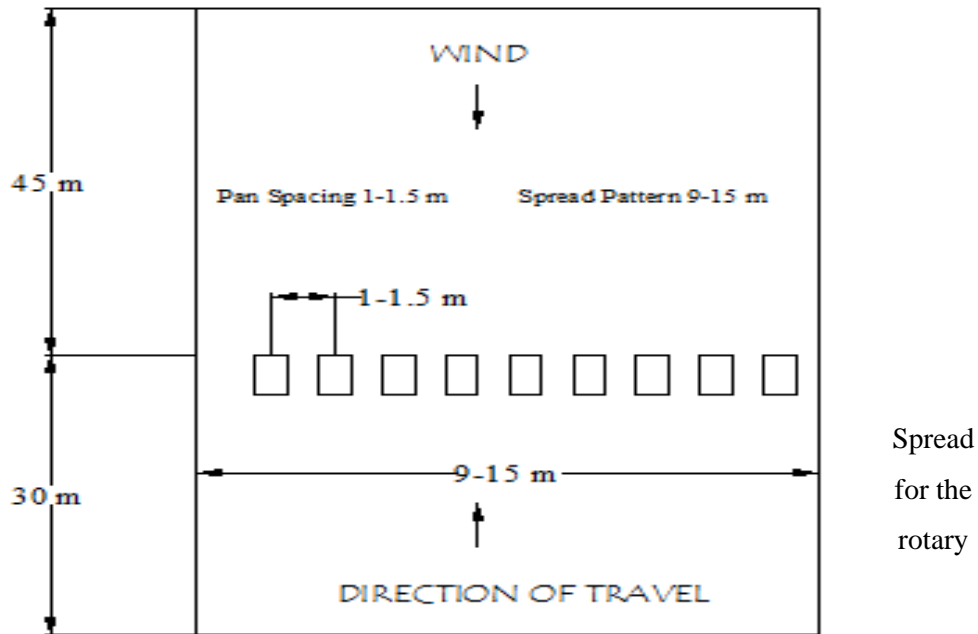

Spread  
for the  
rotary

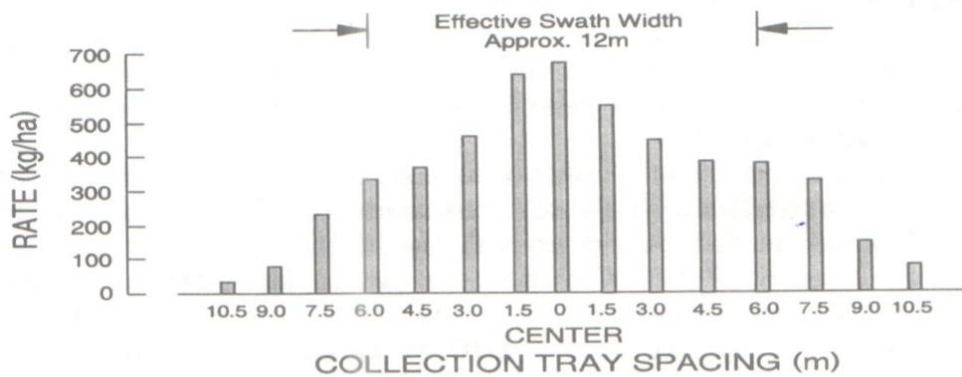

Fig. 16.15 Experimental distribution pattern and the effective swath width

## 16.4 Calibration of sprayers

### 1) Calibration of boom sprayer

Steps for the calibration of boom sprayers

1. Select the required nozzles and fixon sprayer boom arms to deliver the expected application rate.
2. Fill the sprayer tank with water upto a known volume
3. Find out the effective width “W” of sprayer as

$$W = (\text{Number of nozzles} \times \text{the distance between two adjacent nozzles})$$

4. Calculate the length of travel “L” in meters that has to be travelled to cover an area of 0.1 ha.

$$L = (10000/W) \times 0.1 = 1000/W$$

5. Operate the sprayer at desired spray pressure (kPa) and recommended field travel speed to cover the distance “L”.
6. Refill the tank to the original volume. Measure the refilled quantity of liquid used. Multiply it with 10 to get application rate per hectare.
7. Repeat the trial three times and calculate average application rate
8. Compare the results with manufacturer’s specifications

### Example No. 16.1

Find out the application rate of liquid fertilizer applicator containing 1.5 kg of solution having 30 % of N in 36 s, if the sprayer field speed is 7 km/hr and has 6 nozzles on boom spaced 1m apart.

#### Solution:

Data Given

Chemical weight	= 1.5 kg with 30% N
Time to deliver chemical	= 36 sec
Sprayer field speed	= 7 km/hr
No. of nozzles	= 6
Distance between two nozzles	= 1m

$$\begin{aligned} \text{Nitrogen application rate} &= \frac{1.5 \text{ kg solution}}{36 \text{ s}} \cdot \frac{0.3 \text{ kg Nitrogen}}{1 \text{ kg solution}} \cdot \frac{3600 \text{ s}}{\text{hr}} \\ &= 45 \text{ kg Nitrogen/hr} \end{aligned}$$

$$\text{Application rate} = \frac{45 \text{ kg Nitrogen}}{\text{hr}} \cdot \frac{10000 \text{ m}^2}{\text{ha}} \cdot \frac{1}{\text{m}} \cdot \frac{1 \text{ hr}}{7 \text{ km}} \cdot \frac{1 \text{ km}}{1000 \text{ m}} = 62.28 \text{ kg/ha}$$

**Example No. 16.2**

A boom sprayer pump develops 300 kPa pressure to deliver 2 L/min of spray to ten nozzles. The water concentrate ratio in the tank is 10:1 (10 water:1 spray concentrate). The sprayer boom is 50 cm above ground and has nozzles adjusted at 75 cm distance between adjacent nozzles. The liquid consists of 0.5 kg of active ingredient (AI) in each 15 L of spray concentrate. Find out the field application rate for field speed of sprayer as 8 km/ hr.

**Solution:**

Given

Pump discharge rate = 2 L/min

Fluid Pressure = 300 kPa

Concentrate ratio = 10:1

Field speed of sprayer = 8 km/ hr

No. of nozzles = 10

Nozzles spacing on boom = 75 cm

Liquid chemical = 0.5 kg of AI in each 15 L of spray concentrate

$$\begin{aligned} \text{AI delivering rate} &= \frac{2 \text{ L spray solution}}{\text{min}} \cdot \frac{60 \text{ min}}{\text{hr}} \cdot \frac{1 \text{ L concentrate}}{11 \text{ L spray solution}} \cdot \frac{0.5 \text{ kg AI}}{15 \text{ concentrate}} \\ &= 0.36 \text{ kg AI / hr} \end{aligned}$$

$$\text{Application rate} = \frac{0.36 \text{ AI}}{\text{hr}} \cdot \frac{1 \text{ hr}}{8 \text{ km}} \cdot \frac{1}{0.75 \text{ m}} \cdot \frac{10000 \text{ m}^2}{1 \text{ ha}} \cdot \frac{1 \text{ km}}{1000 \text{ m}} = 0.6 \text{ kg AI/ha}$$

To measure travel speed, sprayer's tank is half filled of water over the same type of terrain on which the actual sprayer would be operated. Mark two points 50 m apart with a measuring a tape. The tractor is started from initial point -1 to the final point-2. Time elapsed is recorded for going and coming back between the two pegs and average time is calculated for 50 m in the same tractor gear and rpm. Use following relationship to calculate the travel speed.

$$S = \frac{D}{T} = \frac{\text{m}}{\text{s}} \cdot \frac{1 \text{ km}}{1000 \text{ m}} \cdot \frac{3600 \text{ s}}{1 \text{ hr}} = 3.6 \frac{D}{T} \text{ --- 16.11}$$

Where, S = Travel speed (km/h), D = Distance (m), T = Time in seconds

## 2) Calibration of a Knapsack sprayer

1. Add one liter water into an empty sprayer and prepare it for spraying.
2. Spray on a dry hard surface and wet it at normal walking speed. Walk forward, continually spraying until the sprayer is empty. Measure area covered. (Let it is 20 square meter)
3. Let sprayer size = 15 liter.
4. One liter sprays=20 square meter area.
5. Then 15 liter sprays= $20 \times 15 = 300$  square meter area.
6. Let spray application rate of ProBiactive = 5L /ha (5,000ml/ha)
7. One tank sprays =  $300 \text{ m}^2$
8. To cover 1-ha, no. of tanks= $10000/300 = 33.3$  tank
9. Application rate=5 liter=5000 ml
10. Medicine per tank= $5000/33.3 = 150$  ml



## 3) Orchard Spraying

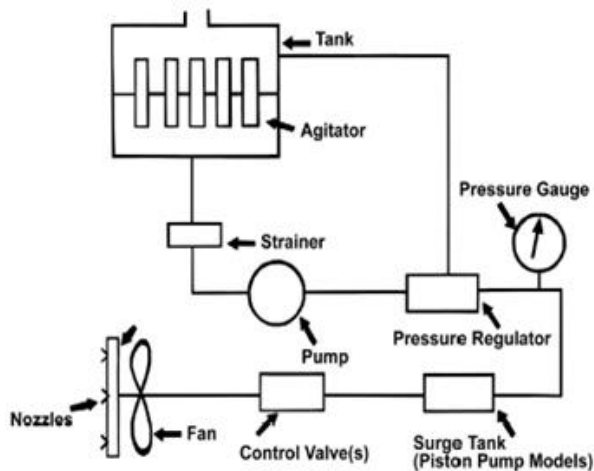

2/3 - 3/4 spray directed toward top half of tree  
 1/4 - 1/3 spray directed toward bottom half of tree

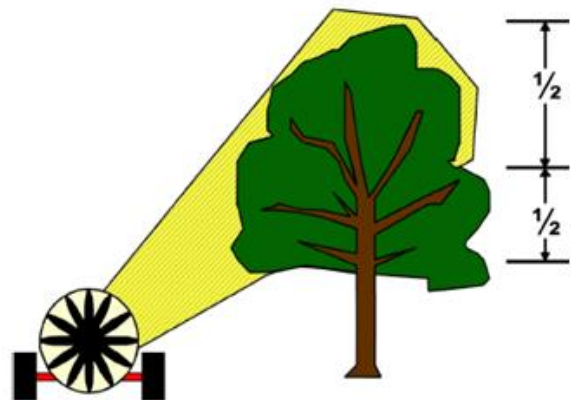

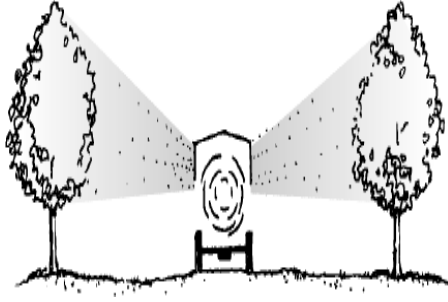

- Proper Dosage.
- Protective Clothing
- Weather Consideration
- Machine Maintenance
- Calibration
- Machinery Sheds
- Trained Driver & Workers
- Well maintained tractor /power source



**Tractor operated Sprayer**

### **Calibration of Orchard Sprayer**

Proper maintenance and operation of a sprayer is the first step in optimizing spray quality.

Assumption - The mechanical parts of a sprayer—like the hoses, pressure gauges, pumps, and agitators—are working properly.

Optimizing spray applications takes time initially, but will pay off with better coverage, improved pest control, and less culls. Follow six steps for calibrating sprayer.



### 1. Check Speed

In the orchard, mark a 100-foot path with two stakes. With a stopwatch, record the time it takes for the front tire of the tractor to pass from one pole to the next. Use this formula to check the speed

$$S = \frac{\text{distance, ft}}{\text{time, s}} \cdot \frac{1 \text{ mile}}{5280 \text{ ft}} \cdot \frac{3600 \text{ sec}}{1, \text{hour}} = \frac{\text{mile}}{\text{hour}}$$

### 2. Adjust the direction of the air

Air carries the spray droplets, meaning wherever air goes, droplets will follow. Therefore, it is critical to direct the air into the canopy or adjust for air that cannot be re-directed. Using flagging is a fast and inexpensive way to see the direction of air flow.

- Park the sprayer in the row.

- Tie ribbon (~2-feet long) to every other nozzle body and onto the ends of deflectors (if present) using clips. Ribbon can also be tied to the end of a stick to extend the visualization.
- Turn on the air without the spray. The ribbons should orient just over and just beneath the canopy. Use deflectors to aim air (ribbons) into the canopy. Consider turning off the top and bottom nozzles if they are not spraying into the canopies.

This should be performed for EACH significantly different canopy shape. Record which nozzles are used for each planting and the deflector orientation.

### **3. Match the air volume and speed to the canopy**

Spray should penetrate the canopy but not expel greatly from the other side. Many factors like wind, canopy density, and speed will affect the correct volume of air and ideally there should be an automated method to adjust the air volume as conditions change. However, significant improvements can still be seen with manual adjustments done just a couple of times a season depending on crop growth. The steps below can be measured through the season for 1-2 years as the canopy develops and then recorded for future years.

- Tie ribbon to the top, middle, and bottom branches of the far side of the canopy from where the sprayer is driving.
- One person stands at the end of the row watching the ribbons. Drive by using typical sprayer settings.
- Adjust the sprayer according to the results:
- If the ribbons blow straight out, there is too much air, which is very common early season. Some solutions include reduce fan gear from high to low, put a plywood “donut” under the fan cage, or a cloth shroud around the sides of the fan cage, drive faster, change the tractor settings to gear up and throttle down (not a good option for hills)
- If the ribbon doesn’t move, there is too little air. Solutions: drive slower, increase rpm or fan gear.

**4. Calculate and record the expected nozzle output** - Now that the correct nozzles are used to match the air direction with the canopy shapes. The gallons/minute of the sprayer can be calculated for running pressure in PSI and the desired rate in gallons/acre (GPA).

$$GPM = \frac{\text{gallon}}{\text{acre}} \cdot \frac{\text{mile}}{1\text{hr}} \cdot \frac{\text{ft}}{C} \left( \frac{\text{acre}}{43560\text{ft}^2} \cdot \frac{5280\text{ft}}{1\text{mile}} \cdot \frac{1\text{hr}}{60\text{min}} \right)$$

$$= \frac{GPA \cdot S \cdot W}{495} = \text{Gallon s/M inute}$$

Where; GPA = gallons/acre; S = forward speed, mile/hr; W = swath, ft

**5. Measure Nozzle Output** - This step can be conducted at any time in the year to assess for worn nozzles, but it should be conducted at least once before the season begins.

- Confirm the pressure gauge is at the correct PSI.
- Connect hoses to the nozzles.
- Turn on the sprayer with water flowing.
- Collect the output for 60 seconds into a graduated cylinder marked with ounces.

Any nozzle that is more than 10% off from expected should be replaced. Replace ALL nozzles if more than 2 are bad.

**6. Verify Coverage** - Now that air volume, spray output, and nozzle orientation are correct, confirm your coverage with water sensitive paper (WSP 2"x3") which is yellow paper that turns blue with water droplets. When working with WSP, always wear nitrile gloves as the moisture in your hands turns the card blue. Staple WSP to the top, middle, bottom, inner, and outer leaves of the canopy, or any other place to determine coverage.

In addition, staple WSP to three 1"x2" board that is 2-4 feet long. Place these boards on the *ground* in the first, second and third row opposite the spray to determine how much spray drifted through the canopy onto the mid-row.

Operate the sprayer at the calibrated settings from the previous steps and drive past the trees with WSP. Look at the spray cards to assess coverage. The ideal spray coverage has many fine droplets all over the card without any long streaks of all blue. Areas with all blue mean too much material is being applied which leads to waste and material running-off the leaves.

Make adjustments to the sprayer or nozzle output based on your results.

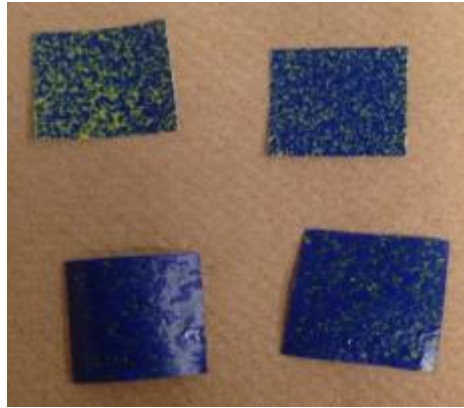

Water Sensitive Paper images

## 16.5 Maintenance and storage of Sprayers

### 1. Maintenance of Sprayers

1. Always use clean water
2. Use recommended screen / mesh size at the spray inlet
3. Use metal object for nozzle cleaning nozzles
4. Always flush new sprayers before their use for field spraying
5. Clean the sprayer thoroughly after spraying in the field

### 2. Sprayer cleaning procedure

1. use kerosene oil and a small brush to clean all screens and boom extensions.
2. use detergent to rinse / clean the spray tank
3. Remove nozzles and use clean water for flushing by spraying through the boom. Repeat this process at least twice.

### 3. Storage of sprayers

1. Store the sprayer under shade at farm yard to protect from rain, frost and sun heat.
2. keep the sprayer away from animals and children

## 16.6 Disposal of Waste containers

Waste containers should be disposed of to reduce the risk to people, animals, crops, water supplies or the environment. To dispose of, follow the rules as below:

1. Always read the label for specific advice on waste disposal.
2. Ask the local supplier of the chemical if he would accept the waste
3. Dispose of the waste through a company or individual licensed to handle waste disposal.

4. Disposed of the waste as soon as possible to avoid accumulation which otherwise often intensifies the risk of contamination through spillage.
5. Never reuse empty containers for the transfer of the same product from a leaking container

Drain all containers, clean and drill after emptying and before disposal. Containers should be buried in the premises owned by the user or a site designated by the Environmental Protection Agency (EPA). The burial site should be chosen to avoid contamination of surface or underground water. Containers should be buried at more than 1-m depth under any land escape. Fencing and marking the area with warning signs should be practiced.

## 16.7 Questions

### Short questions

- Briefly write about the need of sprayers in Pakistan.
- Classify the plant protection equipment.
- Write the benefits and drawbacks of solid chemical applicator.
- Enlist different methods and equipment for chemical applications.
- Write a short note on dusters .
- A row planter is equipped with dry fertilizer applicator with openers spaced 800 mm and operates at a speed of 7.5 km/hr. A bag is placed over one outlet and the planter is operated for 100 m. Calculate the application rate if the material collected is 5 kg.
- A sprayer delivers 3L/ min from each nozzle. Seven nozzles are spaced 1 m apart. The spray concentrate contains 43 g/L of active ingredient. The required application tare is 1.2 kg/ha. If the forward speed is 5.5 km/hr, what will be the spray concentrate-mixing ratio?

### Multi-choice questions

Q #	Question	Ans
1	To spray a hectare of ground crop by spraying less than 60 liters of liquid, is called as: a. Low volume spray; b. Medium volume spray, c. Very low volume spray d. High volume spray	d
2	The economic threshold level (ETL) of spraying is _____: a. Lower than economic injury level (EIL), b. Equal to EIL c. More than EIL, d. Reached when severe damage is done	a
3	If one gram of pesticide formulation having 50% active ingredient is mixed in one-liter water, the ingredient in the spray fluid will be? a. 0.5 ppm, b. 5.0 ppm c. 50 ppm d. 500 ppm	d
4	The air current in a rotary duster is developed by _____. a. Bellows b. Fans c. Self-propelling jacket d. Self-propelling blades	b
5	The solid cone of liquid in a solid cone nozzle is formed due to _____. a. Larger size of the organic plate b. Larger size of the organic plate c. Central hole of swirl plate d. Small size of the strainer	c
6	With a manually operated knapsack sprayer having flat fan nozzle _____ type of spraying is best done. a. High volume b. Low vokume c. ULV d. Semi low volume	b
7	To cover a hectare of rice crop _____ sprayer requires the lowest volume of spray solution. a. Power sprayer b. Foot sprayer c. Knapsack sprayer d. Hand sprayer	d
8	The objective of Integrated Pest Management (IPM) is to _____. a. Keep pest populations below injurious levels b. Increase natural enemies of the pest c. Strengthen the host d. Bill the pests	a
9	For survival of most of the insects, the temperatures should not exceed _____°C. a. 29.9 b. 39.9 c. 49.9 d. 59.9	a
10	A pneumatic sprayer _____. a. Operates using wind or air b. Contains poisonous pesticide c. Is a knapsack type sprayer d. Operates automatically	a

11	The droplet size in normal high volume coarse spray is _____micron. a. Less than 50 b. 50-100 c. 100-300 d. 400-1000	a
12	The hydraulic energy sprayer is a _____. a. Knapsack mist blower b. Controlled drip applicator sprayer c. Knapsack sprayer d. Wheel barrow sprayer	d
13	In a _____, the spray fluid is fed into the air stream within the nozzle and spitted into spray droplets by the velocity of air. a. Disc nozzle b. Annular nozzle c. Shear nozzle d. Low volume nozzle	c
14	The size (diameter in micrometers) of droplets produced by high volume sprayers ranges _____: a. 200-500 microns b. 100-150 microns c. 80-100 microns d. 30-4000 microns	a
15	An aerosol spray has an average droplet size (volume median diameter in micron as: a. 50 b. 50-100 c. 100-200 d. 200-400	a
16	A spray pump used for medium volume spraying is _____. a. Roller vane rotary pump b. Gear type rotary pump c. Plunger pump d. All of the above	a
17	For low volume spraying _____ is used. a. Pneumatic pump b. Piston pump c. Gear type rotary pump d. None of these	c
18	_____ sprayer breaks the spray liquid into fine droplets. a. Nozzle b. Agitator c. Pump d. None of the above	a
19	_____ determines the quantity of spray needed per hectare while using the manually operated knapsack sprayers. a. Swath of spray b. Walking speed of the person doing the praying c. Calibration of the sprayer d. Type of nozzle	b
20	For a proper operation and maintenance of plant protection equipment, _____. a. Lubrication should be followed faithfully using the specified lubricant. b. A multi-grade motor oil should not be mixed with petrol as a fuel for a 2-stroke engine. c. The oil and fuel should be poured separately into the tank. d. The oil and fuel should be poured together into the tank	b
21	To avoid failure of a manually operated sprayer to retain pressure? a. Tighten loose nuts and clamps and replace gaskets b. Tighten the lid of the tank, replace the gasket, if necessary c. Open the nozzle and clean its various parts especially the orifice d. Straighten the plunger rod if found bent	b

## HARVESTING & THRESHING EQUIPMENT

*Engr. Prof. Dr. Muhammad Iqbal, Subject Expert*  
*Engr. Dr. Abdul Ghafoor, Assistant Professor*

### 17.1 Harvesting

The operation of cutting, picking, plucking digging or any combination of these for removing the whole crop or edible part of the crop from either under the ground or above the ground is called harvesting

Mechanical actions associate with harvesting are as follows:

1. Slicing action with a sharp tool.
2. Tearing action with a rough serrated edge
3. Scissoring action.
4. High velocity impact with sharp or dull edge tool.

#### Classification

(1) Manually operated tools (ii) Animal drawn implements (iii) Power driven machines

### 17.2 Cutting tools

**Sickle** - Sickle is a simple manually operated harvesting tool. It is used for harvesting crops like paddy, sorghum etc. It essentially consists of a curved metallic blade and a wooden handle. Sickles are classified into two classes: (i) Plain and (ii) Serrated depending on the nature of the blade edge. In plain sickle the blade edge is smooth and sharp. In serrated sickle the blade edge is with sharp serrated teeth. The plain or serrated edge in the inner side of the blade is used for cutting the crop and hence called cutting edge The forged end of the blade used for fixing the handle is called tang.. Harvesting by sickle is a very slow and labor consuming device.

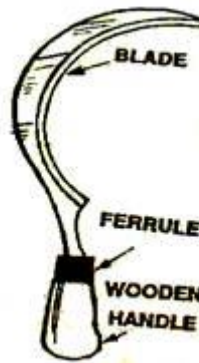

**Figure Sickle**

## Mower

Mower is a machine to cut herbage crops and leave them in a swath. According to the cutting tool mowers are classified as following:

- a) **Cylinder mower:** It has rotating helical blades arranged in cylindrical form. With the rotation of blades, forage or grasses are cut continuously. It is used for trimming grass in lawns, golf grounds etc.
- b) **Reciprocating mower:** It is a mower with a knife made of several serrated triangular sections that reciprocate against stationary fingers. The knife cuts the crop by its reciprocating action. It is the most common type of mower used for harvesting forage crops and food grain crops like paddy and wheat. .
- c) **Horizontal rotary mower:** It is a mower with high speed knife rotating in the horizontal plane. Due to rotation of knife, the grass and forage are cut uniformly. Used for trimming lawns , golf grounds etc.
- d) **Gang mower:** It is an assembly of two or more ground driven cylinder mowers. It is used for trimming grass in lawns, golf grounds etc.
- e) **Flail mower:** It is a mower with high speed swinging knives, operating either in the horizontal plane or in the vertical plane.. Used to cut herbaceous weeds like parthenium

## Conventional Mower

The conventional mower mainly consists of:

- 1) **Frame** - The frame provides space for fitting gears, clutch, bearings, flywheel etc required for the operation of the harvester. A lever is used for lifting the cutting bar during road travel. A flywheel is used to store energy from the engine to supply steady energy to the cutting mechanism for uniform cutting.
- 2) **Power transmitting unit** - It transmits the power from the power source either from the ground wheel in animal drawn mowers and from PTO for tractor drawn mowers to the cutting tool. In tractor drawn semi-mounted or mounted type mowers the cutter bar is operated by P.T.O. shaft of the tractor. A carden shaft transmits drive from PTO to the V pulley of the harvester. From V pulley, drive reaches the knife through gears, crank wheel, connecting rod and pitman. The knife reciprocates and cuts the crop. The cutting mechanism is driven independent of the forward motion of the tractor.
- 3) **Cutter bar** - It is an assembly of several parts comprising of a knife, fingers, wearing plates, ledger plates, guides and shoes. The knife cuts the grass or grain crop by its reciprocating action`. It is a metallic rectangular bar, on which triangular sections are mounted. The knife sections make reciprocating motion inside the fingers and cuts the

plants. There are knife guides with clips to keep the knife sections very closely on the ledger plates for effective cutting action. The knife stops at the centre of the knife guard (finger) on each stroke which indicates good registration.

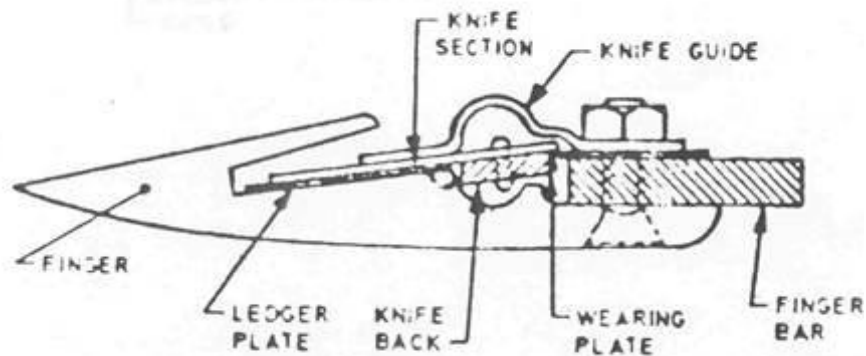
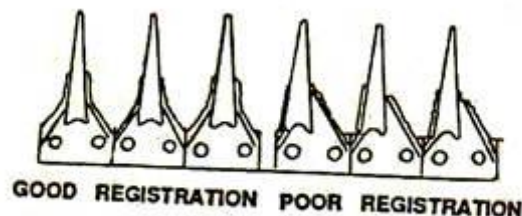

**Figure Cutter bar**

#### **Parts of a cutter bar**

- 1) **Shoe** - A shoe is always provided on each end of the cutter bar to regulate the height of cut and to provide easy and smooth sliding of the cutter bar on the land.
- 2) **Ledger plate** - It is a hardened metal inserted in a guard (finger) over which knife sections move to give a scissor like cutting action.
- 3) **Wearing plate** - It is a hardened steel plate attached to the finger bar to form a bearing surface for the back of the knife.
- 4) **Knife** - It is the reciprocating part of the cutter bar, comprising of knife head, knife back and knife sections.
- 5) **Knife section** - It is a steel plate of triangular shape with two cutting edges.  
**Knife head** - It is the portion of the knife which is connected to the pitman.  
**Knife back** - It is the strip of steel to which knife sections are riveted and the knife head is attached.
- 6) **Grass board** - Grass board is provided at the outer end of the mower which causes the cut plants to fall towards the cut material.
- 7) **Pitman** - Pitman is the link between the knife and crank wheel of the mower. It transmits motion to a knife. Wooden pitman is commonly used for the mowers which acts as safety device. It breaks and protects the cutter bar from damage when ever the knife is locked by some obstacle or choked by the crop.
- 8) **Connecting rod** - It is placed between pitman and crank wheel. It converts rotary motion of crank wheel in to reciprocating motion of the knife.

- 9) **Breaking of knives** - Breaking of knives is a common trouble in operation of a mower. It is caused due to play in bearings and worn out knife head holders. Non-alignment is an important cause for breaking the knife because when the mower is out of alignment, it works on a certain angle which is always harmful.
- 10) **Alignment of mower** - Under working condition, the standing crops exert pressure on the cutter bar tending to push it backward. In correct operating position, the crankpin, knife head and the outer end of the knife should be in a straight line. This line should be at right angle to the direction of travel of the mower. For achieving this object, the cutter bar is set at about  $88^\circ$  to the direction of motion i.e. inward lead of  $2^\circ$  is given to it in order to overcome the back pushing action of the crops. When the cutter bar is properly aligned, the knife and the pitman run in a straight line. This gives better cutting of the knife in the field. Generally 2cm lead per meter length of cutter bar is recommended.
- 11) **Registration of mower** -A mower knife is said to be in proper *registration* when the knife section stops in the centre of its guard ( fingers ) on every stroke i.e. the centre of the knife section is at the centre line of the guard, when it is in operating condition (Fig.3). Adjustment is commonly made by moving the entire cutter bar in or out with respect to the pitman. If mower is not well registered, there is unbalanced load, uneven cutting and excessive clogging of crops on the knife.



Registration of mower

#### Advantages of using harvesters

1. Labor requirement is reduced
2. Large area can be harvested in shorter time. Saving in time
3. The availability of a harvest in a locality supports labor force to complete larger area.  
Hence timely harvest is possible.
4. Economical
5. Frees the land early for plowing for the next crop



**Paddy harvester**

### **Terminology of Harvesting Operation**

- 1. Mower:** It is a machine use to cut herbage crops and leave them in a swath.
- 2. Reaper:** It is a machine to cut grain crops.
- 3. Reaper binder:** It is a machine which cuts the crops and ties them into neat and uniform bundles.
- 4. Sickle:** It is a curved steel blade with sharp edge in the inner side and a handle. It is used by human power. The person holds the tool and shears the straw or stalk and harvests the crop
- 5. Swath:** The harvested material laid on the land by the machine when harvesting is in progress is called a swath.
- 6. Windrow:** It is a row of material formed by combining two or more swaths.
- 6. Windrower:** It is a machine to cut crops and deliver them in a uniform manner in a row.

## **4. Combine Harvester**

It is a machine, which performs the functions of a reaper, thresher and winnower.

### **Classification of combines**

<b>According to threshing and separation</b>	<b>According to power source</b>	<b>According to topography</b>
Conventional (transverse flow design)	Self propelled	Hillside (for hilly area)
Rotary (axial flow design)	PTO driven but pulled by tractor draw bar	Prairie (for plain area)
	Pulled by tractor but powered by an auxiliary engine	

### **Functional process of a combine**

<b>Units</b>	<b>Parts</b>	<b>Functions</b>
Header	Reel, cutter bar, platform auger,	To gather, harvest, and convey crop to throat of feeder
Feeder house	Under shoot conveyor	To convey crop from header to threshing unit
Threshing unit	Cylinder and concave	Thresh crop for separating grain and straw
Separating unit	Straw walkers and grain pan	Separating grain from straw by tossing action and allow grain to fall onto grain pan
Cleaning unit	Chaffer sieve, radial centrifugal air fan	Clean grain from chaff
	Shoe sieve, radial centrifugal air fan	Clean grain from fine chaff
Grain conveying unit	Auger, elevator	Collect and convey clean grain to tank
Tailings conveying unit	Auger, elevator	Collect and convey tailings to thresher for re-threshing
Grain tank	Grain tank, auger	To store clean grain
Grain unloading unit	Unloading auger	To unload clean grain from tank into a trailer

#### **A. Gathering, cutting, pick up, and feeding**

- Reel types:
  - Pick up reel – for tangled/lodged crop
  - Bat type reel – for straight erect standing crop
- Reel axis ahead of cutter bar: 230 – 300 mm
- Crop cutting height: 150 – 250 mm
- Reel teeth be clear from cutter bar: 50 - 75 mm
- Reel speed w.r.t. machine forward speed: 25% fast for wheat; 50% faster for barley

#### **B. Threshing mechanism**

- Rasp bar cylinder and concave – wheat grain threshing by impact and rubbing action (90% grain separation)
- Spike tooth cylinder and concave – paddy kernels threshing by tearing and shredding action
- Angle bar cylinder and concave – oil seed crop threshed by rubber coated angle irons both at cylinder and concave

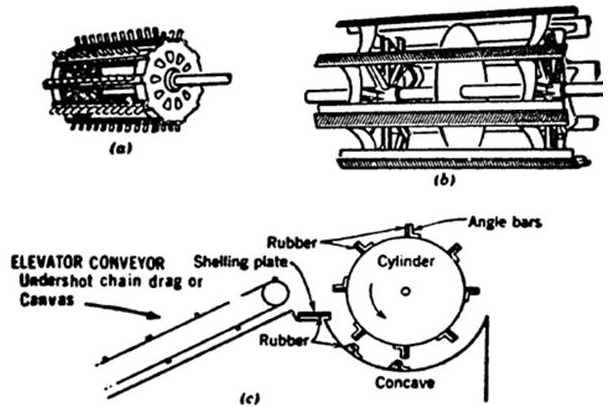

Cylinder design from three different types of combines (a) spiketooth, (b) raspbar, and (c) anglebar

Performance of threshing mechanism is measured by:

$$\text{Threshing efficiency} = \frac{\text{threshed grains, kg}}{\text{total grains entering, kg}} \times 100$$

$$\text{Separation efficiency} = \frac{\text{grains separated at concave, kg}}{\text{total grain entering in threshing mechanism, kg}} \times 100$$

$$\text{Grain damage} = \frac{\text{mechanically damaged grain, kg}}{\text{total grains, kg}} \times 100$$

**C. Separation mechanisms**

Thresher	Combine
All threshed material at cylinder-concave passes to sieves where grains are separated by tossing action of sieves and blowing air of fans	70-90% grains separated at cylinder – concave of combine
Radial fan sucks chopped straw upward and throws horizontally out of thresher	Remaining 30-10% separated at straw walker Un-chopped straw is thrown out on rear side of combine

**Straw walkers** - Straw walker consists of several long sections mounted on two crankshafts (front and rear). Rotation of crank shafts causes the straw walkers to follow an elliptical/circular path. The straw and grain bounces on top of channels and moves to the rear of combine.

During mixture bouncing action, grains pass down through the straw walker slots and straw fall

on the rear of combine.

<b>Straw walker Parameters</b>	<b>Specifications</b>
Number of straw walker sections	3-8
Section width	20-30 cm
Crank throw	5 cm
Crank speed	200 RPM

#### **D. Grain separation and cleaning theory at chaffer and shoe sieves**

The separation occurs due to differences in the terminal velocities of grain and chaff material.

<b>Material/crop</b>	<b>Terminal velocity, m/s</b>
Wheat, oat, barley	5-10
Short pieces of straw	2-5
Short pieces of chaff	1.5-2.5

The mixture of grain, chaff, and small pieces of straw falls from the oscillating grain pan onto the front part of the chaffer sieve. As the mixture falls, a blast of air is directed at  $45^{\circ}$  angle towards the rear of the combine. The air velocity is adjusted such that it carries most of the chaff with it while some of the chaff falls along-with grain onto the chaffer sieve. The remaining mixture of crop material is subjected to the air movement as well as mechanical oscillations. The mat of the of the crop material moves towards the rear of the combine on the chaffer sieve due to the oscillations. The air moving through the mat causes the mat to lose the chaff as it is carried by the air stream while the grains sift down through the mat of chaff and small pieces due to gravity and pass through the openings in the chaffer. The grain and a small fraction of chaff fall on the shoe sieve where the process is repeated. Therefore, the theoretical principles applicable to the cleaning process are:

Aerodynamic separation based on terminal velocities

1. Movement of the crop material on to the chaffer sieve
2. Movement of grain through the chaff straw mat
3. Escape of grain through chaffer openings

The unthreshed grains pass through the tailing auger and go for re-threshing. The clean grain passes through the grain elevator and finally goes to the packing unit. Grains are collected in a

hopper provided at suitable place. The fan is adjusted such that the chaff etc., blown off the rear side of the machine.

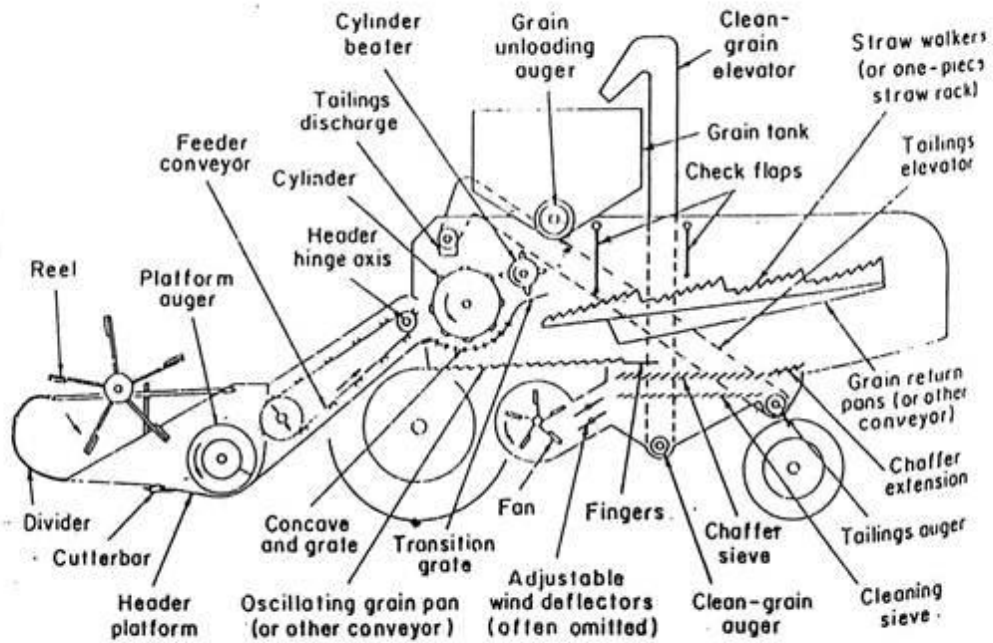

Fig. Schematic arrangement of the basic functional components of a typical self-propelled combine.

## REFERENCES

1. Ahmad, B, S.B. Kokhar, and H. Badar. 2001. Economics of Laser Land Leveling in District Faisalabad, Pakistan Journal of Applied Sciences 1 (3): 409-412, 2001.
2. Ahmad, M.M.A. Zaidi, and A.S. Khan (1994). Development and adoption of no-till technology for sowing wheat. Agricultural Mechanization in Asia, Africa, and Latin America (AMA). Vol. 25(4): 24-28.
3. Ahmad, M.S. 2012. Disaster for small farmers in Pakistan. The AoA and Corporate Agriculture Farming -A Disaster -TheWorld ...[www.worldtradereview.com/webpage.asp?wID=754](http://www.worldtradereview.com/webpage.asp?wID=754)
4. Amjad, N. 2004. Country Report: Pakistan. Presented at Third Session of Technical Advisory Committee of the Asian and Pacific Centre for Agricultural Engineering and Machinery held at Hanoi, Vietnam December 13-14, 2004.
5. AMRI. 2012. Achievements, Agricultural Mechanization Research Institute (AMRI), Multan, Government of Punjab, Pakistan,
6. Anonymous. 2010. Economic Survey of Pakistan. Government of Pakistan. Finance Division, Economic Advisors Wing, Islamabad: 17-37.
7. Anonymous. 2012a. Pakistan Science Foundation. Effect of tractor powered tillage practice on crop yield and soil characteristics. <http://www.psf.gov.pk/abstract.php?id=2>.
8. Anonymous. 2012b. Pakistan Bureau of Statistics. Agriculture Statistics. Pakistan Bureau of Statistics, Statistics House, 21-Mauve Area, G-9/1, Islamabad, Pakistan, E-mail: pbs@pbs.gov.pk.
9. Anonymous, 2012c. Economic survey of Pakistan, Government of Pakistan.
10. Anonymous. 2012d. Mechanization input to farm productivity. Editorial, December 26, 2012, 6:50pm. <http://www.mb.com.ph/articles/387271/mechanization-input-to-farm-productivity#.UPjpDKrn1OE>.
11. ASAE D497.5. 2006. Agricultural Machinery Management Data. 2006 ASABE Standards, St. Josephs, MI.
12. ASAE EP496.3. 2006. Agricultural Machinery Management. 2006 ASABE Standards, St. Josephs, MI.
13. ASAE. 1971. ASAE Yearbook. St Josephs, MI.
14. Ayoola, G.B. 1990. The Marketing of Agricultural Pesticides in Nigeria. National Workshop on the Pesticides Industry in Nigeria. University of Ibadan, 6-8 February 1990. Publication No. 11,
15. Carlson, W., R. Hackathorn, R. Parent, C. Csuri and M. Howard. 1979. Towards an Interactive High Visual Complexity Animation System. Proc. SIGGRAPH.
16. FAO 1997. Guidelines for integration of sustainable agricultural and rural development into agricultural policies. FAO Agricultural Policy and Economic Development Series 4. FAO (Rome, Italy). ISBN 978-92-5-107084-0.
17. FAO Statistical Yearbook 2012 - World Food and Agriculture.
18. FAO. 1993. Food and Agricultural Organization of United Nations Committee on Agriculture Survey Sessions. 77:9-13.
19. FMI. 2012. Commercial products. Farm Machinery Institute, National Agricultural Institute (NARC), Pakistan Agricultural Research Center (PARC), Islamabad. <http://www.parc.gov.pk/fmi.html>.
20. Fraser, R.F. 1956. Proceedings of the 2<sup>nd</sup> international conference on plant protection. Published by Butterworth scientific publications, 88 Kingsway, London, W.C.2.
21. Givan, W. and C. Hammond. 1978. Selection of Farm Tractors. Cooperative

- Extension Service. University of Georgia College of Agriculture. Athens, GA. Miscellaneous Publication Number 68.
22. GOP. 2014. Punjab Information Technology Board, Field Director General Agriculture, Government of the Punjab
  23. GOP. 2004. Pakistan Agricultural Machinery Census, Government of Pakistan, Statistics division, Agricultural Census organization, Gulberg III, Lahore, Punjab, Pakistan.
  24. GOP. 2010. "Pakistan Economic Survey 2009-10", Economic Advisor's Wing, Finance Division, Government of Pakistan, Islamabad.
  25. Hameed, A. and R. Rehman. 1996. Test Report, Pam Penyem Galas PB-16. Knapsack Manual Sprayer. Agricultural Mechanization Research Institute, Multan, Pakistan.
  26. Hanna, S.R. 1985. Comments on Deardorff and Willis Atmos. Env. 18: 1297-1309.
  27. Hobbs, P.R. 1985. Agronomic practices and problems of wheat following cotton and rice in Pakistan. In: Wheat for Tropical Environments. CIMMYT, Mexico: 273-276.
  28. Hough, W.S. and A.M. Freeman. 1951. Spraying, dusting, and fumigating of plant MacMillan Co. New York.
  29. Iqbal, M, Kh. Altaf Hussain, M. Ahmad, and M. Umair. 2010. Development and fabrication of an energy efficient zone disk drill for sowing wheat after harvesting paddy crop. Proceedings of the European Congress on Conservation Agriculture, towards Agro-Environmental Climate and Energetic Sustainability, Madrid, Spain 4-7/10/2010. ISBN: 978-84-491-1038-2.
  30. Iqbal, M. 1996. Type and extent of postharvest losses in horticultural commodities on Pakistan (pp:33-42). *In: Proceedings of national conference on postharvest technology of horticulture commodities, 10-12 September, 1996, Quetta.*
  31. Iqbal, M. 2012. Completion/final report of Project "Prototype development Self propelled multi-crop reaper. Funded by Business Incubation Center, UAF". Principal Investigator: Prof. Dr. Muhammad Iqbal, Chairman, Dept. of Farm Machinery & Power, UAF.
  32. Iqbal, M. and M. Azam. 2011. Completion/final report of project "Skill development in reverse engineering at agri. machinery pool, UAF".
  33. Iqbal, M., H.S. Mahmood, and M. Younis. 2005. Development of a Drop-pipe type University Boom Sprayer. Journal of Engineering and Applied Sciences, N. W. F. P. University of Engineering and Technology, Peshawar, Pakistan, (ISSN-1023-862), 24(1):67-71.
  34. Kalogirou, S., 2003. Potential of solar industrial process heat applications, Applied Energy 76, 337-361.
  35. Kepner, R. A., R. Beiner, and E. L. Barger. 1987. Principles of farm machinery, 3<sup>rd</sup> Edition. The AVI publishing company.
  36. Khan, A.S. and M. Salim. 2005. Rice harvesting and threshing, Postharvest Management Program, National Coordinator, Rice, National Agricultural Research Center, Islamabad, Pak J Food Sci, 15(1-2): 45-52
  37. Leonenko, G., L. Sietse, O. North and R.J. Peter (2013). Statistical Distances and Their Applications to Biophysical Parameter Estimation: Information Measures, Estimates, and Minimum Contrast Methods, Remote Sensing.
  38. Mahmood, H.S., M. Iqbal, Kh. Altaf Hussain, and T. Hameed. 2004. Improved surface coverage with environmentally effective university boom sprayer. Pakistan Journal of Agricultural Sciences, Society for the Advancement of Agricultural Sciences, University of Agriculture, Faisalabad, Pakistan. (ISSN 0552-9034), 41(1-2):152-157.

39. Majid, A., M. Aslam and N. I. Hashmi .1988. Potential use of minimum tillage in wheat after rice. In: Klatt, A.R. Wheat Production Constraints in Tropical Environments. ISBN 968-6127-22-4. CYMMYT, Mexico, D. F.
40. Mathews, G. A. 1992. Pesticide application methods ( 2<sup>nd</sup> ed.) Wiley, New York.
41. Memon S.Q., B.Mirza, and G.R. Mari. 2007. Growth and yield of maize crop. J. Agricultura Tropica Et Subtropica, 40(3):89-100.
42. Metcalf, J.R. 1958. Leakage in Ventilation Tubing. The Mining Magazine, May.
43. Munir, A. 2007. Agricultural Engineering Research in Pakistan: An Overview, Impact, and Restructuring. Paper presented at the International Seminar on Restructuring and Strengthening Research & Development for Agricultural Engineering, Beijing, 27-28 April 2007.
44. Okoro, O.I and T.C. Madueme. 2004. Solar energy investments in a developing economy, Renewable Energy 29, 1599-1610.
45. Punjab Development Statistics 2011. Bureau of Statistics, Government of the Punjab. Lahore <http://hdl.handle.net/123456789/13021>. Date: 2011 ...
46. Raja, M.B and K.M. Khokhar. 1993. Postharvest horticulture technology and its future prospects (pp:265-277). In: proceeding of first international horticulture seminar, 09-11 January 1992. Pakistan Agricultural Research Council, Islamabad.
47. Reed, T. (1984). Wear life of agricultural nozzles. ASAE Paper No. AA84-001. St. Joseph, MI: ASAE.
48. Rehman, R.1994. Research and development of nozzles in Agricultural Mechanization Research Institute, Multan, Pakistan.
49. Sheikh, G.S. and M.S. Sabir (1984). Adaptation and development of low and medium pressure sprayer for spraying different crops. A report of a project completed by the Faculty of Agricultural Engineering, University of Agriculture, Faisalabad and Technology and Punjab Agricultural Research Coordination Board, Lahore.
50. SIB. 2010. Sector/Industry Briefs. Farm Implements & Machinery.
51. Sims, B.G. and J. Kienzle. 2010. Farm equipment supply chains guidelines for policy-makers and service providers: Experiences from Kenya, Pakistan and BrazilFAO Rural Infrastructure and Agro-Industries Division, Food and Agriculture Organization of the United Nations
52. SKF. 2008. [www.skf.com.pk](http://www.skf.com.pk).
53. Srivastava A. K., C. E. Goering and R. G. Rohrbach. 1993. Engineering Principles of Agricultural Machines. In: Hansen, P.D. (ed). Chemical Application. ASAE, 2950 Niles Road, St. Joseph, Michigan, 49085. pp. 265-324.
54. Srivastava, N.S. 2012. Farm power sources, their availability and future requirements to sustain agricultural production. [agricoop.nic.in/Farm%20Mech.%20PDF/05024-04.pdf](http://agricoop.nic.in/Farm%20Mech.%20PDF/05024-04.pdf)
55. Thornton, M. E. and K. R. White.1974. Apparatus used for spray nozzle evaluation at the Weed Research Organisation. Pans.20: 465-475.
56. UAF. 2012. Activities -University products identified for commercialization. Endowment fund secretariat, University of Agriculture, Faisalabad, Pakistan.[www.uaf.edu.pk/endowment\\_fund/end\\_activities.html](http://www.uaf.edu.pk/endowment_fund/end_activities.html) - 10k
57. UAF. 2014. Mechanization package, Punjab, Pakistan. University of Agriculture, Faisalabad, Pakistan
58. Weaver, M. and R. Grisso. , Publication 442-452. Plumbing Systems of Agricultural Sprayers, Publication 442-452, Biological Systems Engineering Department, Virginia Tech. Extension Pesticide Coordinator, Entomology Department, Virginia Tech
59. Wolf, R.E. 2010. Pumps for Applying Crop Protection Products. Kansas State University Agricultural Experiment Station and Cooperative Extension Service.

60. Zalom, F. G and W. E. Fry.1992. Food, Crop Pests, and the Environment: The Need and Potential for Biologically Intensive Integrated Pest Management. APS Press, St Paul, MN.