

Andrea Simitch and Val Warke

With essays contributed by

Iñiqui Carnicero

Steven Fong

K. Michael Hays

David J. Lewis

Richard Rosa II

Jenny Sabin

Jim Williamson

the  
language  
of  
architecture

26 Principles  
Every Architect  
Should Know

the

**language**

of

**architecture**



Brimming with creative inspiration, how-to projects, and useful information to enrich your everyday life, Quarto Knows is a favorite destination for those pursuing their interests and passions. Visit our site and dig deeper with our books into your area of interest: Quarto Creates, Quarto Cooks, Quarto Homes, Quarto Lives, Quarto Drives, Quarto Explores, Quarto Gifts, or Quarto Kids.

#### Dedication

To all of our students, from whom we have learned so much. And to Eva and Dax, who have not only tolerated but infinitely enriched our endless excursions in the interest of architecture.

© 2014 Rockport Publishers

First published in 2014 by Rockport Publishers,  
an imprint of The Quarto Group,  
100 Cummings Center, Suite 265-D,  
Beverly, MA 01915, USA  
T: (978) 282-9590 F: (978) 283-2742  
[www.QuartoKnows.com](http://www.QuartoKnows.com)

All rights reserved. No part of this book may be reproduced in any form without written permission of the copyright owners. All images in this book have been reproduced with the knowledge and prior consent of the artists concerned, and no responsibility is accepted by producer, publisher, or printer for any infringement of copyright or otherwise, arising from the contents of this publication. Every effort has been made to ensure that credits accurately comply with information supplied. We apologize for any inaccuracies that may have occurred and will resolve inaccurate or missing information in a subsequent reprinting of the book.

Rockport Publishers titles are also available at discount for retail, wholesale, promotional, and bulk purchase. For details, contact the Special Sales Manager by email at [specialsales@quarto.com](mailto:specialsales@quarto.com) or by mail at The Quarto Group, Attn: Special Sales Manager, 100 Cummings Center, Suite 265-D, Beverly, MA 01915, USA.

#### Library of Congress Cataloging-in-Publication Data

Simitch, Andrea, author.

The language of architecture : 26 principles every architect should know / Andrea Simitch • Val Warke.  
pages cm

Summary: "Learning a new discipline is similar to learning a new language; in order to master the foundation of architecture, you must first master the basic building blocks of its language - the definitions, function, and usage. *Language of Architecture* provides students and professional architects with the basic elements of architectural design, divided into twenty-six easy-to-comprehend chapters. --- Provided by publisher

ISBN 978-1-59253-858-4 (paperback)

1. Architecture. I. Warke, Val K., author. II. Title.

NA2550.S56 2014

720--dc23

2014008552

ISBN: 978-1-59253-858-4

Digital edition published in 2014

eISBN 978-1-62788-048-0

Design: Poulin + Morris Inc.

Page layout and production: *zabuli.nasa* graphic design

Cover image: Pezo von Ellrichshausen/[www.pezo.id](http://www.pezo.id)

Photo: Cristóbal Palma

42 S-61

Andrea Simitch and Val Warke

With essays contributed by

Iñiqui Carnicero

Steven Fong

K. Michael Hays

David J. Lewis

Richard Rosa II

Jenny Sabin

Jim Williamson

the  
language  
of  
architecture

26 Principles Every  
Architect Should Know



# Contents

## Introduction 6

---

### ELEMENTS

8

10

26

---

### GIVENS

36

48

58

---

### PHYSICAL SUBSTANCES

64

72

82

88

---

### EPHEMERAL SUBSTANCES

100

108

116

124

---

**CONCEPTUAL DEVICES**

132

138

144

150

---

**ORGANIZATIONAL DEVICES**

156

164

172

180

188

---

**CONSTRUCTIVE POSSIBILITIES**

196

202

---

**CONCLUDING**

208

Glossary 216

Bibliography 217

Contributor Directory 218

Photographer Credits 219

Index 220

About the Authors 224

Acknowledgments 224

# introduction

**It is our hope to stimulate old and new interests in architecture, to share an enthusiasm for some venerable sheds and evocative cathedrals, and to introduce the limitless poetics that can be composed in architecture's language.**

Tireless debate has always focused on the qualities that could cause a building to be described as "architecture." Nikolaus Pevsner, who famously declared that "A bicycle shed is a building; Lincoln Cathedral is a piece of architecture," assumes that human habitation is a characteristic of all buildings, while architecture transcends building because of its aesthetic aspirations. Other arguments have been based on issues as indeterminate as emotional resonance (in other words, architecture, unlike building, stirs our emotions), as reductive as professionalism (architecture is by architects), as evaluative as historical appraisal (architecture is what a culture has deemed as significant, or what has proven to be significant through time), and as limitless as inclusivism (all constructions are architecture, perhaps even those by other species, such as the hives of bees or the dams of beavers).

Parallel to these discussions, analogies to language have been frequent, varied, and inevitable throughout the history of architecture. The fact is that every building, from a bicycle shed to a bus stop, is capable of meaning something to someone: "Here, I can protect my bike from the rain," or "This is

the stop near my home." But it is clear that those constructions we describe as "works of architecture" tend to convey countless levels of meaning to numerous unique observers over an indefinite number of years. Perhaps, then, architecture might be understood to be comparable to a "thick," poetic language.

One of the traits of any language is that it provides a system that can convey meaning. When being introduced to a new language—when one first learns to speak as an infant or when one attempts to learn a second language—meaning is generally direct and singular. To the infant, a "dog" is the furry four-legged beast in the room. To the first-time speaker of Italian, "cane" is directly associated with one among that general group of animals we know as "dogs." However, after becoming familiar with more complex levels of language—with poetry, slang, mythology, and allegory, for example—a more sophisticated notion of meaning is required. For example, when Shakespeare has Hamlet say:

*"Let Hercules himself do what he may,  
The cat will mew and dog will have his day,"*  
Shakespeare, Hamlet, Act V, Scene 1

our elementary concept of the meaning of "dog" becomes complicated by the various affects of context, by our knowledge of dramatic genres, of precedent, of poetic language, and, if heard during a performance, by the actor's verbal and physical inflections. Clearly, Shakespeare's "dog" is much more than that furry four-legged beast once in the room.

Meaning in architecture is similarly complex, both profound and open ended. Such meaning is inevitably compounded by architecture's lengthy processes of production, by the vast array of individuals responsible for every stage of that production, by the final construction's relationships with its various contexts, by its interrelationships with other known elements of architectural expression, and by the unique pasts and presents of each individual who observes the final construction. Architecture is further complicated by the fact that each design is a testing ground for a number of associated concepts drawn from history, theory, technology, and even representation. For this reason, many attempts at defining a language of architecture have necessarily been reductive. Like textbook translations of elementary Italian, they

become simple exercises in decoding, with no regard for syntax, idioms, voice, genre, and so on.

For these reasons, this book is not intended to be an exhaustive or definitive lexicon of architectural ideas. Such an effort would be futile. It is instead an introduction to what we believe—after over sixty years of combined experience in architectural education—to be some of the more vital fundamentals of architectural design. Just as the English alphabet is arbitrarily limited to twenty-six letters, we have limited ourselves to just twenty-six elements, each described in its own chapter.

We have organized the text so that we begin with three chapters that introduce the essential elements one needs to develop a visual language and the skills for critical thinking: analysis, concept, and representation. We follow with three of the elements that are generally considered to be among the givens of any design process: program, context, and environment. Then, we turn to what might be considered the substances of architecture. After introducing the physical substances—mass, structure, surface, and material—we consider the equally palpable,

but more ephemeral substances—space, scale, light, and movement—that serve to make the physical substances legible. Four chapters on the conceptual devices that frequently contribute to what might be understood as the poetics of architecture—dialogue, tropes, defamiliarization, and transformation—are followed by five chapters that discuss the operations of architecture's diverse organizational devices: infrastructure, datum, order, grid, and geometry. Finally, two chapters concerning some of the considerations an architect might have for the implicit possibility of construction—fabrication and prefabrication—are followed by a final chapter on what is usually the culmination of the design process for most architects and students of architecture: presentation.

And we illustrate these chapters throughout with some of the more distinctive and expressive examples of architecture's language. From the grandiloquent to the slang, from the epic to the everyday, projects are culled from the great masters of architecture, from notable contemporary practitioners and from students around the world who have confronted these issues in their studies.

We address this book to several different audiences. For those just commencing studies in architecture, we hope to introduce the potential breadth and depth of the field while showing some of the works—by both students and well-known practitioners—that might inspire or even provoke. Those who have already embarked on one of the various aspects of architectural practice might find in the text a series of subtle reminders, a mine of possibilities. Each chapter includes a short essay that brings greater depth to the chapter's theme and may suggest further inquiry for those interested in architectural history, theory, or criticism. And finally, for those of our colleagues interested in developing a curriculum in beginning design, we intend each chapter to germinate an idea that might foster its own design exercise or that could suggest more elaborate problems when combined with other themes.

In short, it is our hope to stimulate old and new interests in architecture, to share an enthusiasm for some venerable sheds and evocative cathedrals, and to introduce the limitless poetics that can be composed in architecture's language.

# analysis

**Analysis is an investigation organized to uncover what may have been the strategies for a project's design.**

*Originality* is a term often used to describe something new or different, something that has never been done before. In architecture, there is a firm belief that most everything has already been done, to some extent and in one manner or another, and that originality does not lie in the discovery of something new but in the interpretation

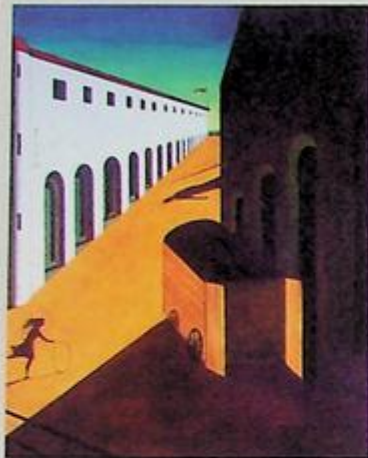

Giorgio de Chirico: *Mystery and Melancholy of a Street*, 1914. Private collection.



Aldo Rossi: Gallarate II Housing, Milan, Italy 1974  
Aldo Rossi's Gallarate II Housing block in Milan takes not only certain formal cues from Giorgio de Chirico's trancelike metaphysical painting, *Mystery and Melancholy of a Street*, with a giant loggia surmounted by a cadence of square windows, but there is also a similar sensibility of urbanism, of buildings as monumental backdrops that impressively modulate individual activity while suggesting the mysteries that might be hidden in their shadowy depths.

and appropriation of something that already exists. It is not that *something* that is the subject of this chapter, but it is, instead, the processes by which one understands, abstracts, and interprets the known or the given so that it can meaningfully inform the design process. In architecture, these processes of abstraction are usually called *analysis*.

#### *Project Givens*

The design process is initiated by the intersection of two circumstances. One is the

givens of a project, which include program (the functions that the project needs to accommodate; these may include specific material requirements, such as the use of aluminum), site and context (where the project is to be located), and conventions (the cultural contexts of the project). The other circumstance is what the architect brings to the givens: how the architect interprets or defines these givens. Analysis is the process of exploration and discovery with which an architect not only develops a familiarity with the assumptions, expecta-

tions, and conditions that are given, but subsequently establishes the critical framework of the problem, the conceptual lens through which all design decisions are subsequently made.

#### *Precedent*

Fundamental to the education—and continued development—of an architect is an awareness of what has come before. It is the raw material that provides the basis for an infinite inventory of architectural ideas: it is the architect's library, allowing the architect

(continued on page 13)

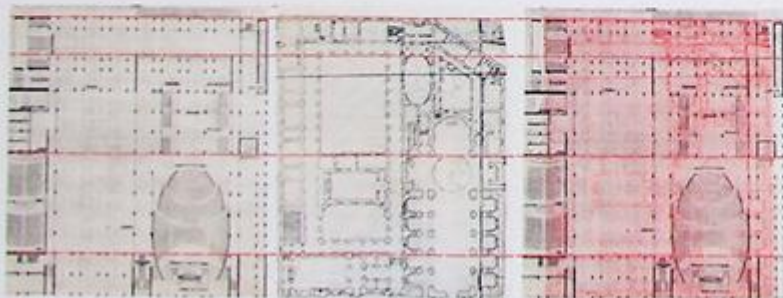

These plans show Giuseppe Terragni's design for the Congress Hall for the Rome International Exposition (E42) of 1937 (left) in relation to the Oratory Complex of Saint Phillip Neri (1620-50), also in Rome, by Francesco Borromini and others (center). While the structures are extraordinarily different in their three-dimensional

development, it is clear that the modern building derived significant inspiration from the plans of the Oratory, borrowing the older complex's geometries as well as its basic distribution of programmatic spaces.

# Luigi Moretti and the Evocative Precedents of Architecture

In the 1950s, the austere architecture of postwar Italy—dominated by that of the increasingly industrial north—was constricted by a lingering classicism. The Roman architect Luigi Moretti confronted this world through his magazine *Spazio*, or *Space: Review of Arts and Architecture*, (1950–1953, with a few issues in the 1960s). *Spazio* was dedicated to presenting select contemporary architecture—both built and unbuilt—in the context of developments in the fine arts, with provocative essays suggesting that architecture could derive intensity from the arts, crafts, and buildings of past masters and unknown artisans. For Moretti, this included especially the architecture that was roundly condemned as decadent by most European modernists: that of the late Renaissance and baroque periods.

The essays in *Spazio* would usually take the form of an analysis: verbal, graphic, and occasionally both. Moretti himself would often analyze aspects of the arts in their possible relationships to architecture. For him, analysis was intimately tied to the design process, not simply to understand what may have transpired in the past, but to advance what is and could be happening in the present. Moretti's analyses represented an active process: We read them not as finished works but as unconstrained ruminations—often as brilliant as they were reckless—intended to draw the reader into a speculative discourse.

In the first issue, Moretti's "Eclecticism and Unity of Language" finds modern expressionism present in the brush strokes of Rubens, and surrealism in the fabrics of fifteenth-century paintings by Cossa. Eclecticism, argued Moretti, is a necessity



1. Michelangelo. Progetto per la Chiesa di S. Giovanni del Fiorentini in Roma. Rappresentazione dei volumi interni. 2. Fama (da un'incisione di Federico Reguardi). 3. Roma. Foro Iulio. Accademia di scultura (L. Moretti). Rappresentazione dei volumi interni e vista delle gronde alla 5. Mies Van der Rohe. Brno. Casa Tugendhat. Compi visuali degli spazi interni; zona di lettura definita (strategia sovrata) e zona di impossibile intuizione della forma (strategia forte)

Portion of page from "Structures and Sequences of Space" illustrating (from top down): a model of the spaces within Michelangelo's San Giovanni del Fiorentini in Rome; a plan of that church; a model of the spaces within Moretti's Fencing Academy in Rome; an interior view of the Fencing Academy; and diagrams of the plan of the Tugendhat House in Brno, by Mies van der Rohe, illustrating perceived spatial zones (heavy lines) and intuited spatial zones (shorter lines) from various points within the house.

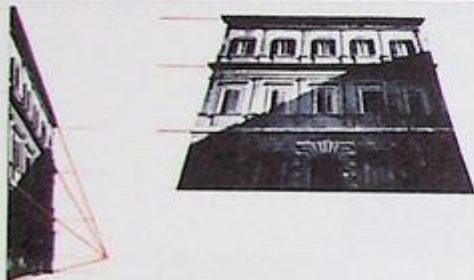
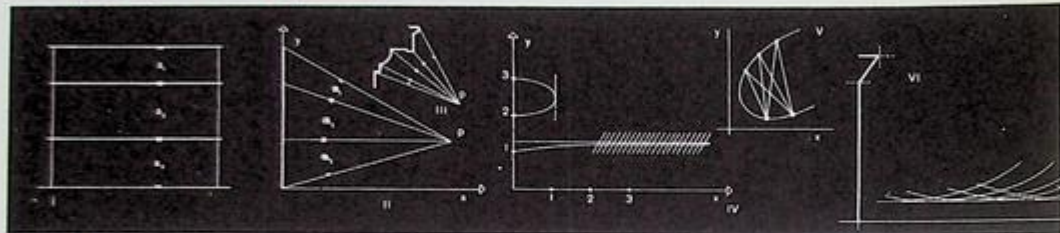

Analyses of profile elements of Baldassarre Perruzzi's Palazzo Ossoli in Rome, tracing the lines in perspective as well as with views of projections

in a complex, multicultural world. In the third issue, Moretti treats the work of Bernini and Borromini compositionally in "Abstract Forms in Baroque Sculpture," in which exuberant draperies and angels' wings supply the plasticity that defines Roman baroque architecture. Rather than encourage a stationary viewer, he argues, these fluid forms draw the eyes from one center to another—from one perspectival system to another—in works composed of multiple focal points, simulating an architectural promenade.

Moretti reveals a fascination with movement, sequence, and time as modifiers of space and form. In "Discontinuity of Space in Caravaggio," Moretti speculates that this painter from the early seventeenth-century was depicting the effects of Rome's noonday light upon elements in baroque façades, when columns appear as figures and

shadows consume the "inconsequential" elements of nonloadbearing surfaces.

In "The Values of Profiles," Moretti argues that cornices and profiles (three-dimensional moldings) are ancient architecture's truly "abstract" components: nonrepresentative and formally derived. Profiles, according to Moretti, have been architecture's means of orchestrating light and dark, thereby bringing focus to a building's components and reinforcing its primary formal organization. Moretti demonstrates how moldings enable a building to alter its appearance throughout the day with continuously changing shadows, and in relation to a viewer's position in the street below: a genuinely dynamic architecture.

In perhaps his most famous essay, "Structures and Sequences of Spaces," Moretti analyzes spatiality in architecture in four

aspects, both empirical and psychological: as a measurable sequence of volumes represented through plaster models with spaces constructed as solids; as "density" defined by the penetration of light as modeled with light boxes; as the foci of one's senses on the masses that shape a structure; and as the expansive and compressive interrelationships within the fluidity of a spatial sequence. Always eclectic, Moretti cites nineteenth-century paintings, the spatial reactions of characters in a film, the cathartic escapes in Melville's *Typee*, and fluid dynamics.

In his *Spazio* essays, Luigi Moretti offers evocative analyses framed by juxtapositions and generous speculation, arguing that every type of artistic work can be absorbed into an architectural production.

Left: Machado and Silvetti: *House in Djerba, Tunisia, 1976, plan*

Right: Castle Hedingham, Essex, England, c. 1155, plan

It is possible to derive basic organizational strategies from one's understanding of precedents. The occupiable wall that wrapped the primary rooms of the medieval English castle is combined with the typical Tunisian troglodyte house in

which an excavated courtyard is surrounded by its primary living spaces, to provide inspiration for a project designed by Machado and Silvetti in Djerba, Tunisia. Here, the exterior wall of rooms that enclose the house's central volumes is transformed into an exterior staircase, and as it begins to peel away, the central volumes of the house are revealed.

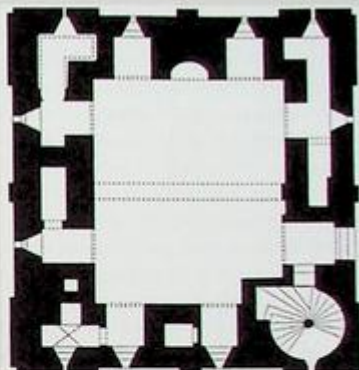
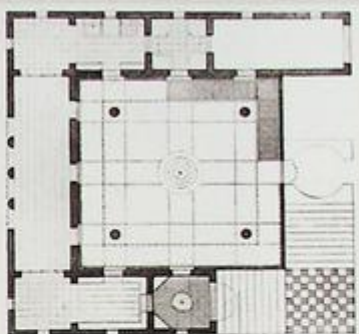

to quickly identify works that have evolved in response to similar programmatic, contextual, or cultural circumstances, or that may offer a repertoire of formal solutions that can inspire solutions to problems that may at first seem unrelated. As Álvaro Siza Vieira has said, "Architects don't invent anything; they transform reality. They work continuously with models that they transform in response to the problems that they encounter."

This knowledge can be made useful only if it undergoes a series of thoughtful transformations that increasingly abstract and distill those fundamental characteristics of a source that are relevant to the problem at hand. It is only then that a simple imitation can be replaced by the genuine generative potential of the precedent.

Precedents can originate from within or outside of architecture. They can inform a project's form or its organization, its structure or its circulation, its internal operations or its outer membranes. They can be buildings or cities, films, or paintings. They can be animals or machines, biological behaviors or fictional narratives. Designs often have more than one precedent.

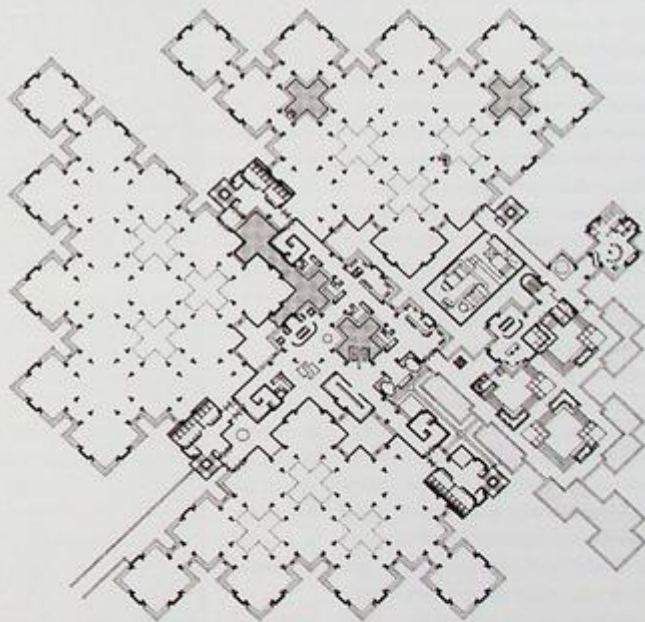

In his design for a building in Apeldoorn, the Netherlands, completed in 1972, architect Hermann Hertzberger cast in concrete and masonry his theories that a building should be a communal structure, in effect, a small village, containing streets, plazas, and gathering spaces both formal and informal.

Hertzberger is able to recast his analytic understanding of traditional, canalized Dutch towns into the scale of a modern building where the village's density that serves to create its cultural vitality is interpreted as a series of densely packed miniature office towers peering out over interior streets.

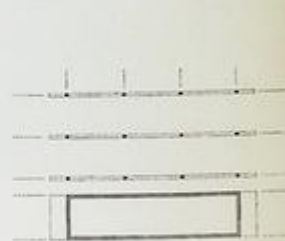
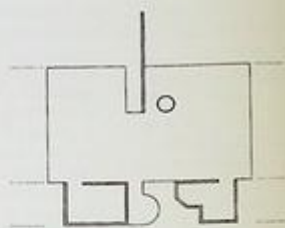
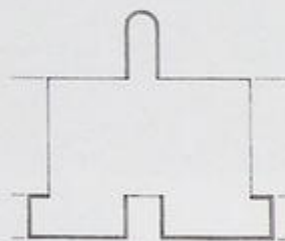
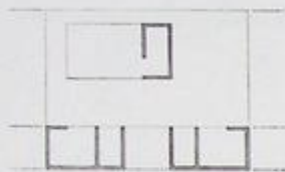
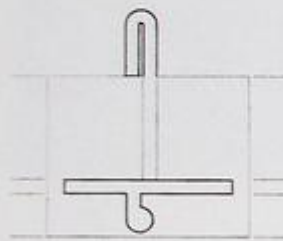
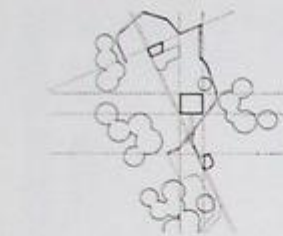

## ABSTRACTION

Just as an artist sees a painting through the eyes of someone intending to produce another painting, and a musician might hear music with the ears of someone intending to produce more music, an architect sees a building—ultimately, analyzes it—with the goal of designing another work of architecture. For the architect, the role of analysis is not to uncover the fundamental intentions that may have been behind a design's origin, but to uncover the values a design may have in inspiring more designs.

Analysis is a process whereby one draws from a precedent or from a programmatic given its distinguishable characteristics, what makes one work different from any other work. "Analysis," as Cornell University Professor Jerry Wells would say, "is designing backwards." It is breaking down a work into parts in order to examine a subject from multiple perspectives, to investigate a project in order to uncover what may have been the strategies for its design. While these parts are often formless, they are the precursors of the concepts and forms that have produced the final work.

*Components, or breaking down into parts*  
Most works of architecture are composed of a series of overlapping and bypassing systems that, together, form the complete work. It is the "unpacking" of these systems into a series of discrete diagrams that can offer insights into a precedent's unique characteristics, and it is the distillation of these systems into idealized components that can provide an inventory of systems that can subsequently be redeployed in other projects.

The most common systems separated during an analysis are structure, circulation, exterior envelope or membrane, major versus minor spaces, public versus private spaces, solids versus voids, repetitive versus unique, supportive spaces, and the geometric and proportional orders that often hold these systems together.

While each system on its own is important in understanding a work, the ways in which they are transformed, merged, or overlaid is what ultimately leads to an understanding of the unique qualities of the greater whole.

Richard Meier: House in Pound Ridge, NY, 1969

In these iconic diagrams by the architect Richard Meier, site, program, structure, entrance, circulation, and enclosure are independently represented in order to present the project's basic

organizational strategies. While describable as a series of autonomous systems, each following an "internal" logic, together they form a constellation of systems that intersect, engage, and often deform one another in producing the final work.

*Diagramming*

Diagramming is the process of abstracting and simplifying an idea so that it can be easily understood. It is the recording of the physical and spatial characteristics that identify the unique and recognizable characteristics of a building, site, or program. It is the process by which familiarity with a specific set of programmatic and contextual circumstances can be achieved. Much like a child's sketch, a diagram is not concerned with developing nuance but, instead, with clarity; it is a reduction—a boiling down—of an idea. The diagram cannot only analyze the physical, it can also reveal the ephemeral, the historical, the infrastructural. Diagrams allow one to gain an understanding of a particular project by revisiting it again and again through a series of distinct lenses. They also facilitate an understanding of how several seemingly unrelated works might in fact be brought together as an inventory of thematically related conditions. And, finally, diagramming can also facilitate the quick exploration of alternate solutions to a problem in its initial stages of development. The diagram not only maps the identity of a given project, but points the way to the conception of a new project. And it is in these reductive, abstract states that diagrams often resemble more universal conditions.

**INTERPRETATION**

It is the simplicity of the analytical diagram that allows for its subsequent interpretation and transformation when introduced to a new set of parameters.

*Intermediary Device*

The synthesis of an analysis often leads to the production of an intermediary device, an artifact that is subsequently open to multiple interpretations. This device is, in effect, a 'prearchitectural' moment. It can take the form of a drawing or model, and it is a suggestive and interpretable representation that has the ability to shift in both scale and

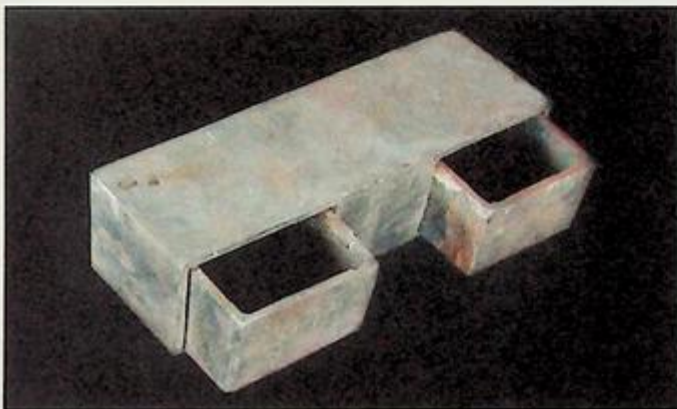
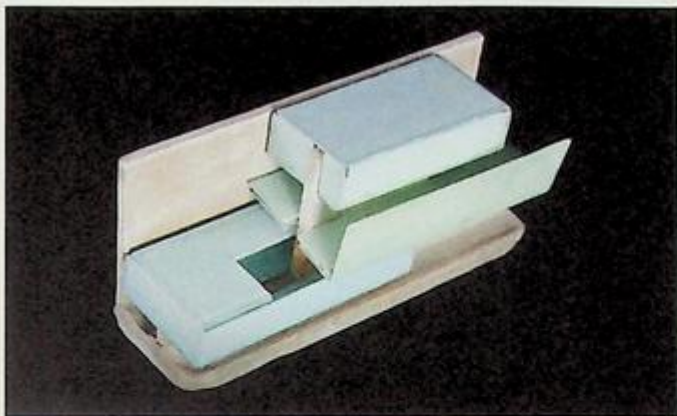

A series of analytical models demonstrates alternate formal and material strategies for a Danish

Design Center that students were asked to design in a 2006 freshman design studio at Cornell University.

orientation so that it can be conceptually mined in multiple ways. It is the testing of these interpretations within the parameters of the design problem—the “what-ifs”—that motivates the development of an architectural concept.

For example, a diagram might isolate the circulation of a building as the unfolding of a spatial sequence, one that might collect a series of views. And, yet, while the specificity of the views or the modes of circulation—such as stair, ramp, bridge, and so on—may be important to the original project being analyzed, an analytical diagram might record a more generic condition of an armature that collects a series of things (such as views, programs, experiences, or scales). It is this diagram that has the ability to sponsor the production of an intermediary device—perhaps a miniature construction or a composite

drawing—where the specificity of the precedent gives way to an instrument that subsequently motivates the final work.

Embedded in the intermediary device are the potential concepts of the new work. It operates as an “in-between artifice” that retains the concept of the precedent yet leaves behind the specific attributes with which the original work is associated. In reinterpreting diagrams with an intermediary device, issues of scale and proportion, even of material and enclosure, may be insignificant. The value of the intermediary device is precisely located in its intermediate condition, on the threshold of interpretation and innovation.

#### *Cocreation*

An analysis always represents the encounter of at least two spheres of awareness: the minds and cultures of a work's original

designers and makers, and those of the new architect. Therefore, whenever one analyzes a work, one is essentially cocreating that work.

Analysis does not necessarily attempt to “solve” a work, to resolve its hidden schemas or to penetrate the deepest mysteries of its authorship. Instead, analysis brings to a work a type of “deep reading,” whereby probing and questioning reveal the potentials and significances of a precedent. Ultimately, with practice and awareness, analysis becomes for the architect a mode of seeing and understanding a work, of absorbing the work into a creative memory where objects and ideas become the raw materials for the authorship of new designs.

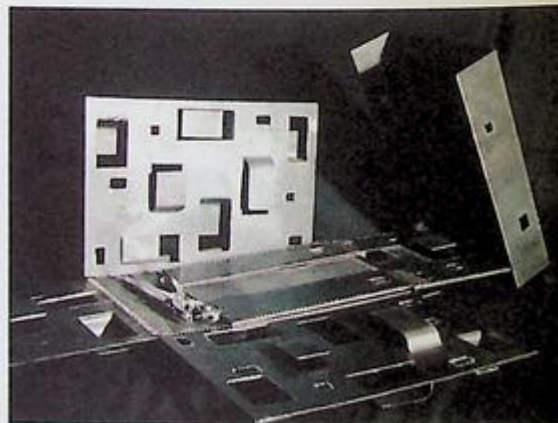
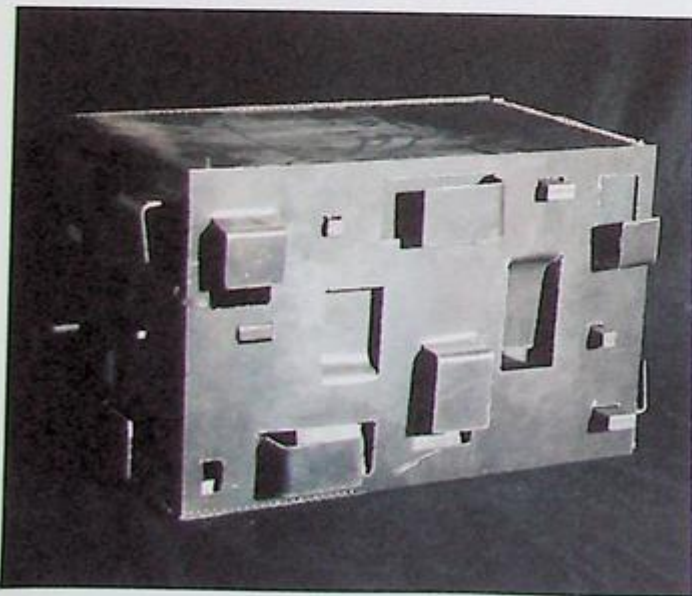

In a 1998 introductory design studio at Cornell taught by Professors D. Lewis and A. Simitch, students were each asked to analyze a prosaic tool and then construct a container that would not only house the tool but that would register the tool's formal, operative, and material

characteristics as were discovered and demonstrated through their analysis. This steel container for a holepunch served as the intermediary device for the design of a showroom whose spatial characteristics were to reference the original tool for which it was now a showcase.



A concept is often at the nucleus of a design, to be gradually refined and subtly reconsidered as a process proceeds.



# concept

**A concept is rooted in simple abstractions, yet it initiates a process that usually ends with a complex design.**

The process of architectural design is much like a voyage. At the start of this voyage, it is the development of a coherent architectural *concept* that not only suggests a possible destination, but that also supplies the traveler with both an oar and a rudder.

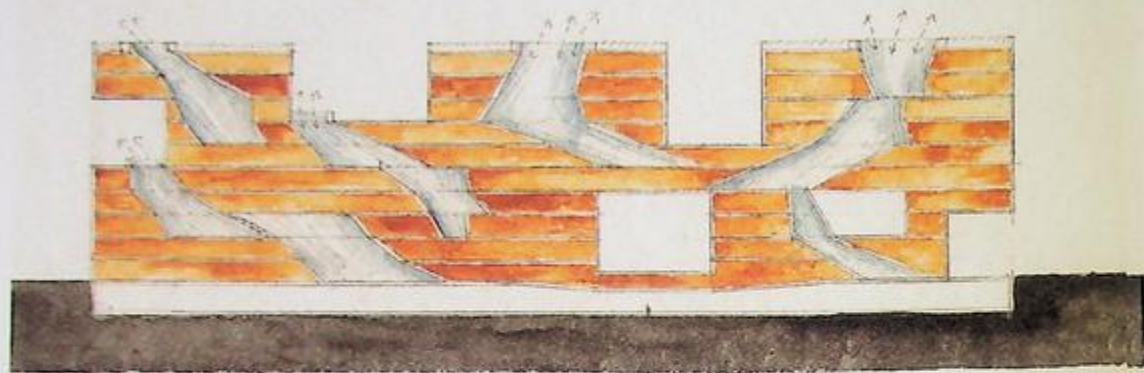

MIT 2001 (Simmons) SPONGE

LIGHT & AIR VENTILATION (AIR DRAWS UP THROUGH MASS YOUNGEST VIA SLOW RPM FANS OPERATED BY ROOF TOP PHOTOVOLTAIC CELLS)

### What It Is and What It Does

A concept represents more than a solution; it poses a way of thinking about a design problem while proposing a set of objectives while implying potential exclusions. It is a route to be taken while excluding potential detours. The concept initiates the action of design.

#### *Versus Ideas*

While a concept might originate with an idea or set of ideas, an observation, or a prejudice that is personal to the designer, these ideas alone rarely motivate a production. In order to have a productive value, an architectural concept should eventually result in an observation that can be shared with a larger audience. And, while intrinsically an abstraction, a concept also differs from an idea in that it has an obligation to suggest an image or a thing, since it must inevitably lead to a constructive proposition.

For example, using light wells to bring additional light into a building might be an idea. However, on its own, the notion of including light wells does little to limit a design's range of unique possibilities. That the building might be like a sponge, with light wells penetrating in an organic, irregular manner throughout (as with Steven Holl's Simmons Hall at MIT), or that light wells



might simultaneously provide tubular structural and mechanical supports for the building (as with Toyo Ito's Sendai Mediatheque), represent ideas elevated to the level of architectural concepts.

#### *And Flexibility*

However, while it might be the nucleus of a design, the concept may become gradually refined and subtly reconsidered as a process proceeds. Far from being a fixed idea, a concept must remain flexible, roomy enough to permit the inevitable adjustments as a design evolves.

(continued on page 23)

Steven Holl's original watercolors for Simmons Hall, a dormitory for MIT in Cambridge, Massachusetts (completed in 2002), propose that the concept of "sponge" would give this building its identity. The concept conveys

numerous attributes: a regular exterior form is penetrated by organically shaped tubes providing light and ventilation while linking the more public spaces through various levels with contrasting formal vocabularies.

# Sverre Fehn— Projecting the Line

Sverre Fehn's body of work is concerned with the metaphysical relationship of man to his world and his buildings become the devices for reconciling the vastness of that world and the human experience within it. His work is a complex conversation between the natural and the constructed, between light and dark. The projects operate as conceptual lines that simultaneously measure the landscape while locating the human being within it.

A three-dimensional line is struck amongst and within the ruins of an existing barn at Hamar—and it is one's movement along and occupation of this line that constructs one's relationship to both the stone ruins and the archeological artifacts that have been retrieved from the earth. In a 1992 interview with Maija Karkkainen, Sverre Fehn explains: "... I conceived Hamar Museum as a kind of theater, where the movement is in specific routes around smaller objects, around bigger objects, and around the whole space, which in turn winds around historical excavations ..."

The essence of the project lies in the dialogue that is established between the carefully calibrated and precisely constructed 'present' as it is juxtaposed onto the irregular archeological ground of history. This present is manifest as a series of materially, spatially, and structurally distinct elements that occasionally align themselves with the existing ruin and then caper off to their own material and geometric tune. This fundamental concept of a series of independent layers, of which the present is but one, provides the conceptual lens through which all architectural decisions are subsequently filtered and at all scales. The wooden structure that shelters the three-dimensional path descends from the sky and alights onto the ruined walls that are solidly grounded by the earth. The



concrete ramps and walkways that tiptoe through the ruins occupy this constructed space between earth and sky. They not only provide the access through which the visitor navigates this 'suspended museum' but they register the architectural concept through their material and geometric difference. These ramps swell to become volumes within which special collections are displayed—each artifact mediated with enormous precision by a material that again negotiates between the present layer and its cultural past. A hand knife rests on a soft leather cloth that is inlaid into a wooden surface that bears the imprint of its weight; a wooden plow deforms a steel plate that suspends it from the concrete wall. Each material has its own behavior,

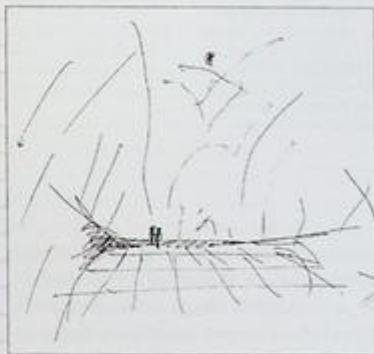

Norwegian Glacier Museum  
Fjaerland, Norway, 1989-1991  
view and perspective

its own voice, and tells its own story, yet like a repertory theater, continuously engages and responds to the other members of its material troupe.

The architect has often described the 1989-91 Norwegian Glacier Museum in the Fjaerland district of Norway as a stone that rolled off the glacier and settled into the valley below. As the vastness of the site makes any building structure inconsequential, the architect's ambition was to create a place between sky and ground. Thus, the concept for the museum was developed as a concrete plinth sitting on the earthen floor, from which the visitor could experience this spatial panorama. The primary space of the museum is therefore not its interior but the

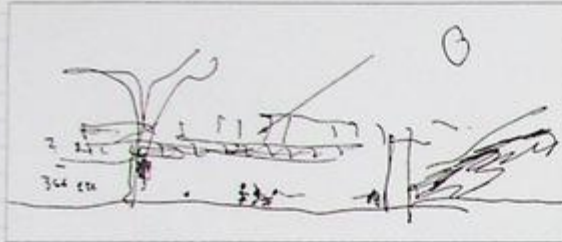

Nordic Biennale Pavilion,  
Venice, Italy 1958-1962  
conceptual sketch-section,  
and view of roof structure



outdoor room of the valley in which the hollow rock has settled. The stair leading up to the plinth aligns with the glacier beyond; here the projected line is an instrument that orients and locates the visitor in the space of the landscape.



It is often the framing of the problem that leads to the development of the architectural concept and with the 1958-1962 Nordic Pavilion at Venice Biennale the problem that Sverre Fehn identified here was quite simple: how to protect and display the artifacts within a context that simulates the Nordic light in which they had been produced. The concept for the project then emerged as the construction of light, a three-dimensional *brise soleil* that is rotated horizontally to simultaneously protect the artifacts and, through its layers of stacked concrete beams, produce the "shadowless" light that is so typical of the Nordic landscape. The geometry of the system allows it to adjust its dimensions as necessary to accommodate the magnificent trees that occupied the site. It serves to measure, to locate, the landscape, the light and the artifacts within its Venetian site.



The Heđmark Cathedral Museum  
Hamar, Norway 1968-88  
conceptual sketch, view of interior

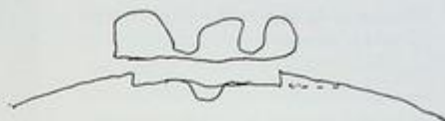

The original concept sketch by Jarmund/Vignas Arkitekteter of Norway for a house on the dunes shows a crownlike object hovering above an incision in a hill. The dashed line suggests a ramp or cut in the hillside for an entry. Built in 2010 in Thorpeness,

England, under the sponsorship of *Living Architecture* magazine, the ambitions of the "thumbnail" sketch are accomplished with a glazed ground floor with minimal structure above which an irregularly domered upper floor appears to float.

概念的にツリーハウス、海岸の砂を柱、ファサードのスクリーン  
 へ要素だけしてビルトを完成する。木材のエレメントを構造的に  
 エレメントのシリアルに組み立てる。これは全力をあげて、これはかなり void  
 にしてやる。

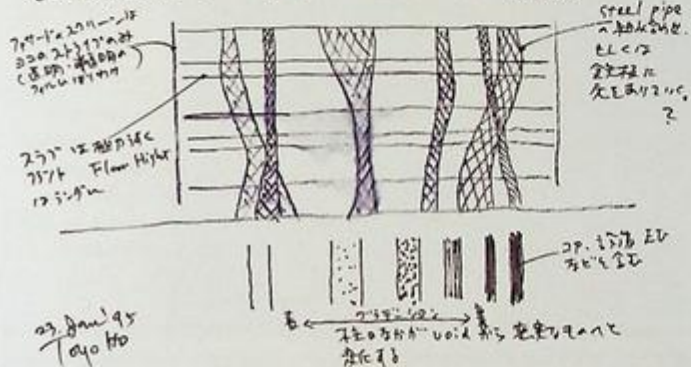

Toyo Ito's early conceptual sketch of his Sendai Mediatheque, located in Sendai-shi (the "City of Trees"), Japan (completed 2001), shows large, hollow tubes formed by a network of latticelike surfaces, growing like tree trunks through a series of floor slabs. These tubes serve as light wells while contributing to the building's structural stability. Although some are primarily structural, others enclose elevators, with the smaller, twisted "trunks" containing electrical and air handling systems. This innovative structural system, designed with the engineer Matsuro Sasaki, incurred only minor damage in the magnitude 9.0 earthquake that struck Japan in March of 2011.



## The Sketch

In architecture, the first articulation of a concept is usually in the form of a drawing or a sketch model. Conceptual sketches and models indicate that a position has been taken, while providing a measure against which design decisions can be evaluated and alternatives weighed. As generative tools, sketches provide the visual language with which architects test conceptual notions in their relationships to a set of goals or parameters. Embedded within the conceptual sketch is the seed for the development of the project: it is, in a sense, the pregnant drawing.

While most drawings tend to communicate to others, a sketch may be a more private form of drawing—a personal ideogram—intended as a note to oneself or as a succinct communication between the designers within a team.

## The Thumbnail Sketch

Among conceptual sketches, the thumbnail sketch is a drawing that—aided by its small size—is necessarily a caricature of the concept: that is, it represents the reduction of the concept to its most identifiable characteristics, inevitably exaggerating those characteristics for the purpose of clear recognition. For this reason, the thumbnail sketch remains throughout the design process a valuable representation of a design's essential objectives as well as a constant reminder of the latent ambitions within the concept, as a baseline measurement of a design's development, and as a litmus test for any design that might lose its way.

Conceptual sketches facilitate a continuous critical conversation between abstract concept and the *form* that the concept can embody. While thumbnail sketches and early conceptual drawings are initially loose and open ended, often without scale, proportion, or specificity, it is through the reiterative process of enactment, critical response, evaluation, and modification that a sketch—and its latent design—becomes increasingly more specific.

Ultimately, the collection of conceptual sketches throughout the design process forms the diary of a project, recording an architect's creative process in terms of the formal ruminations that reveal the evolution of the conceptual idea.

#### *The Overlay*

Perhaps one of the most valuable techniques in developing a concept is through the use of the *overlay*. From the time that Michelangelo used the subtle translucency of his paper to generate alternative designs on the backs of previous drawings, the notion of the overlay has played an important role in the development of architectural sketching. With the development of inexpensive, mass-market tracing paper in the early 1800s, architects could easily transform designs through a process of revision, reaccentuation, and reorganization. As older drawings fade beneath cloudy layers of tracing paper, newer layers are kept in sharp clarity on top. Not only did tracing paper decrease the necessity for tedious redrawing, but the layering of information facilitated a designer's ability to view constantly renewed images of the project while providing a frequent shift of focus.

While some contemporary computer graphic programs attempt to duplicate the flexibility of tracing paper, this is accomplished without the tangible, recorded "debris" of numerous intermediate stages. It is often in these intermediate stages that an intuition can be rediscovered and reemployed.



Using paper models, architects ARX of Lisbon can quickly study a number of volumetric concepts for a high school in Caneças, Portugal, each reinforcing a

different concept of education. These projects integrate classrooms—the spaces of traditional, formal learning—with the more fluid spaces of "informal."

communal learning. Three-dimensional models permit the simultaneous testing of the concept in terms of site, program, light, space, and human habitation.

#### **The Sketch Model**

Supplementing the basic conceptual sketch, and often equally important in the elaboration of a concept, are three-dimensional "sketches," in particular relief and concept models.

#### *Relief Models*

A low-relief model is often cut from paper that is then folded, twisted, or warped, often while retaining much of the surface of the original paper. Relief models suggest aspects of potential three-dimensional forms as they might relate to the plane of the ground or to a specific viewpoint as in a perspective image. Especially when illuminated from an oblique angle, these models suggest a possible composition of masses, a strategy of landscape engagement, a potential perspective view, or patterns of light and shadow.

#### *Material Models*

A concept model might use cardboard, metal, clay, plastics, or other materials to suggest the physical relationships that various volumes might have to each other or to model possible forms based on material textures or behaviors,

such as density, transparency, reflection, erosion, stretching, bending, and cracking. These models do not attempt to represent a realistic representation of a design, but instead to suggest ways in which a design's components might act and interact.

#### **And Otherwise**

An extension of the architectural concept is the *parti*, or *parti pris*, which had its origin in nineteenth-century France and in the phrase *prendre parti*, which means "to take a position." Just as a position might be taken only after all of the options are weighed, the *parti* is typically derived only after the concept has been determined; it relates to the disposition of elements within the totality of the project. The "*parti diagram*" is generally a succinct diagram—in plan, section, or three dimensions—of the strategy the designer will use in the development of the concept. While a concept is largely rooted in abstraction, the *parti* is rooted in practical application, a knowledge of precedents, a strategy of programmatic distribution, and the sense of an eventual necessity to explain a project to others.

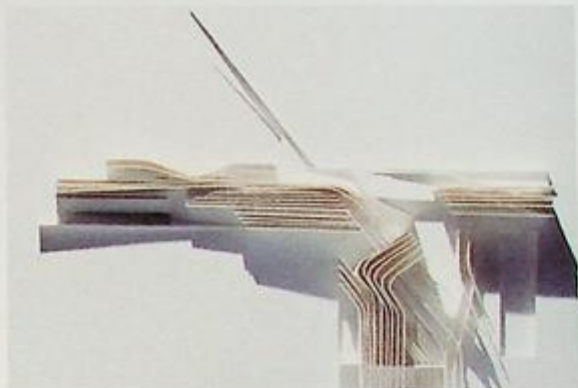

Zaha Hadid used numerous media in developing her design for the MAXXI Museum of XXI Century Arts in Rome, Italy (completed 2009). Sketches indicate the fluidity of paths, basic formal organizations, light control systems, and relationships to the site. Relief models maintain a flexible interpretation of dimension while facilitating studies of light and shadow. Hadid's famous paintings study the effects that luminosity, kinetic motion, the integration of contextual networks and forces, and parallax vision can all have on the design's development.

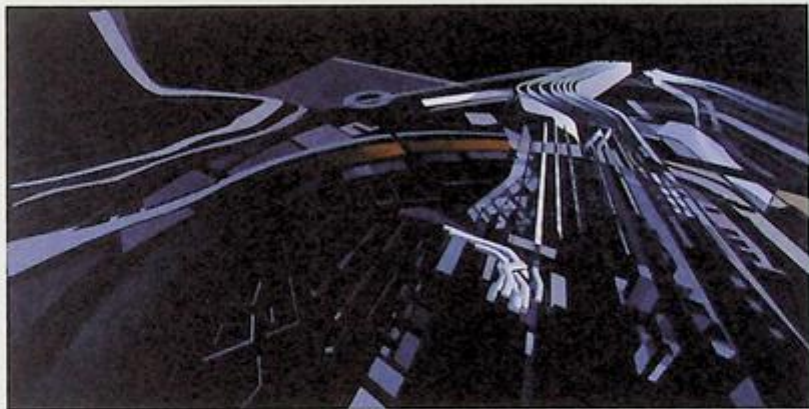

In developing the National Music Centre of Canada (Calgary, Alberta), Allied Works Architecture (Portland, Oregon and New York City) used musical instruments to motivate a concept founded on the principle that a building for music should itself be reverberant and alive with sound. Their formal concept is derived from investigations that included

pipe organs, violins, and sonorous chasms located throughout North America. While the early concept sketches suggested chambers within vertical tubes—as with pipe organs—the concept models evolved to incorporate the behaviors of materials and methods of fabrication in shaping the chambers so that they mimic aspects of natural erosion and fissures.

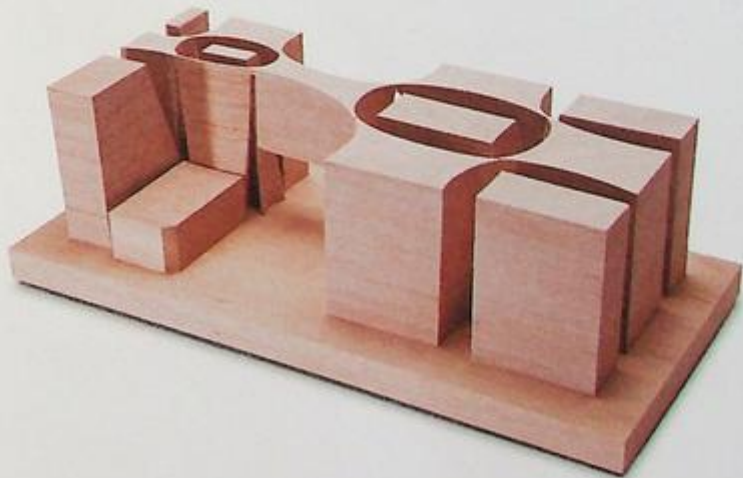

Representation facilitates the examination and expression of architectural thought, filtered through the unique conventions that are embedded within each specific mode and technique of depiction.

# 3

## representation

**The final architectural work inevitably bears the traces of its representational origins.**

Architects do not build buildings, they make the drawings and models from which buildings are made. Take for instance a Scottish *waller* and a Native American basket weaver—what do they share? The medium in which each works is intimately tied to the thing that is produced—they are inseparable.



Michelangelo's Study of Fortifications Number 27 model the walls as sculpted surfaces. Regulating lines that suggest cones of vision (and angles of gunfire) provide the geometric underpinning for the overlay of thickened lines whose bistré infill registers the

massiveness of the walls. For Michelangelo it was this blurring of representational boundaries that allowed his sculptural sensibilities to translate into architectural form while simultaneously fulfilling the fortifications' defensive requirements

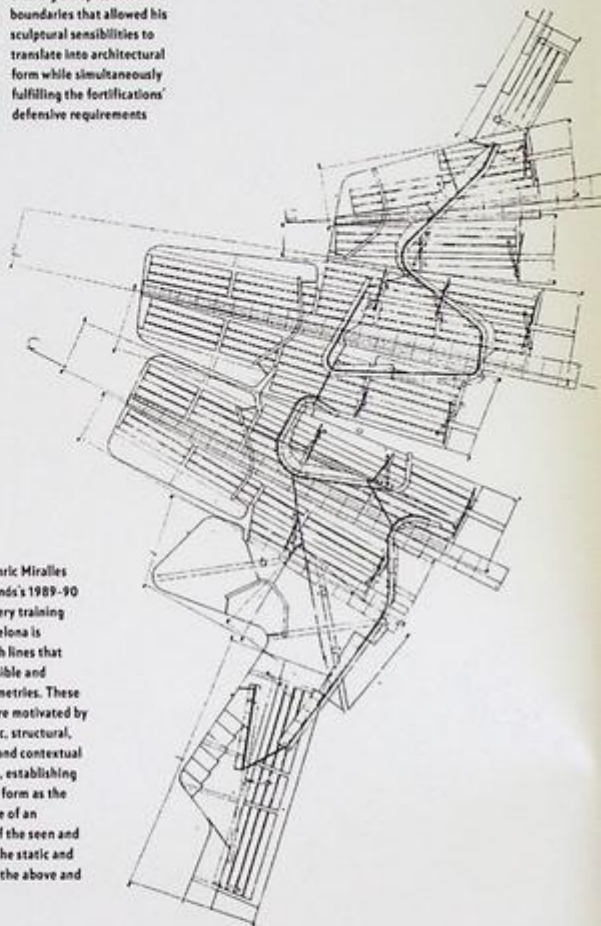

The plan of Eric Miralles and Carme Pindó's 1989-90 Olympic archery training range in Barcelona is saturated with lines that mark both visible and invisible geometries. These geometries are motivated by programmatic, structural, experiential and contextual relationships, establishing architectural form as the tangible trace of an archeology of the seen and the unseen, the static and the animate, the above and the below.

Here, too, then is the argument that for the architect, the representational tools (a drawing, a model—be they analog or digital), and the typologies (be they, say, a plan or a section, a drawing or a model) that are used in the *development of a concept* are to be understood as accomplices to that concept—and that the final work will inevitably bear traces of their influence.

### Tools

Let us begin with a discussion of the tools of the trade—the media with which architects work. Paper was the 'ground' of the Renaissance architect where pen and ink drawing for, perhaps, the first time served to represent *ideas* for buildings. Drawings at multiple scales and views were often superimposed one upon the other to serve as traces of a creative stream of consciousness. These permanent ink marks operated much like handwriting and often served as a binding contract between architect and client. And while the tools have evolved and expanded considerably since the Renaissance, drawings and models remain the primary media of the architect in both developing, representing, and executing architectural concepts.

### Analog

Just as a building is composed of a series of independent systems that together construct the structure, the analog drawing can be understood as an archeology of lines—a registration of multiple layers and ideas within a surface—that together register and imply the third dimension. Unique to the pencil drawing is the use of line weight that allows the line to take on hierarchical significance in relation to the various systems that construct

architectural space. If one were to imagine a conversation, one might argue a correspondence exists between the volume of speech and the significance of its content. Now, a scream is not always more effective than a whisper, and so too with the line. In an architectural drawing, the weight of the line establishes a link to its role in constructing architectural space. A very light line might reference an underlying geometry or set of dimensional relationships. A darker, heavier

(continued on page 31)

# Morphosis and the Representation of the Indescribable

Despite their ultimate and obvious solidity and despite their concrete presence, works of architecture begin and then persist as ephemeral constructions. Architecture is born from our remembrance of the architectures we have known and resonate with our expertise in using the tools we are given to produce further architectures. Even after construction, our perceptions of a building are influenced by weather, light, sound, other occupants, the events of our day, our thoughts and memories—dodging and feinting through our minds—all affect how and what we comprehend.

Recognizing this, the work of Thom Mayne and Morphosis proceeds from a commitment to the ubiquitous complexities of our world. It is instigated by the complexities they observe *beyond the work*—in the site, in the program, in history, in human behavior—as well as forming a parallel to the complexities that are always to be found in every type of discourse.

Layers of complexity influence each project from its inception, as Mayne and Morphosis seek to infuse the projects with compound forms, forms that collide, shear, bend, warp, rotate, and that are as often subtracted from each other as added, generally articulated by numerous materials and textures. Just as in the early twentieth century the cubists, futurists, and constructivists attempted works that, despite their essentially static states, represented the increased dynamism of their societies—present in speed, movement, mechanical and industrial devices—the

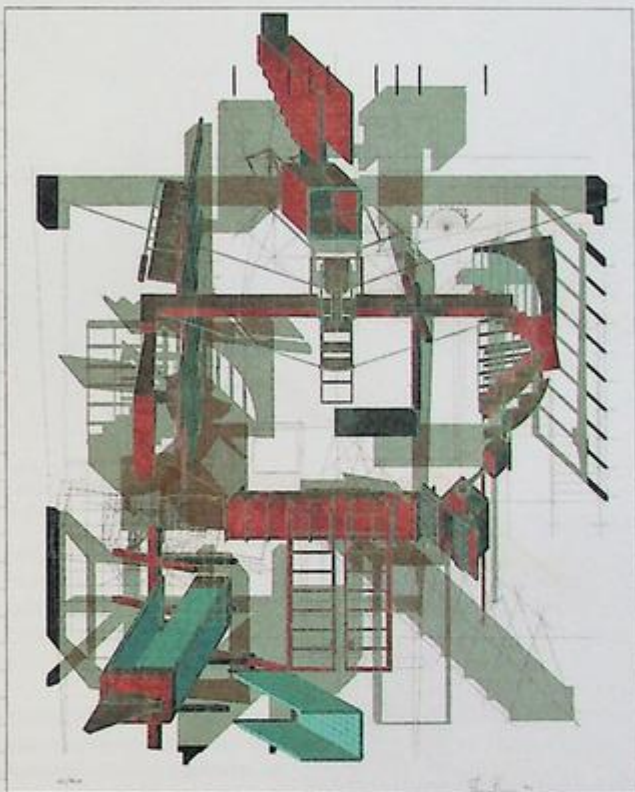

*Sixth Street*: Serigraph, 1988  
Thom Mayne with Selwyn Ting and John Nichols Printmakers



Above: Penang Turf Club Masterplan, 2004  
Study Model, Morphosis



Perot Museum of Nature and Science: Giclée Print, 2009  
Thom Mayne with Kerensa Harris; Jack Duganne (Printmaker)  
and Jeff Wasserman (Serigrapher)

works of Morphosis supplement these influences with each building serving as a record of the dynamism of the process of its production in anticipation of the dynamism of its eventual usage and reception.

In the earlier days of the office, the compounding of forms was achieved largely through the transparency of paper and Mylar: drawings were layered, occasionally even combining various formats of drawings (such as axonometrics, plans, and sections) leaving remnants of an oblique in plan, of a plan in elevation, just as the components of a building might be merged into a larger complex. Occasionally, the materials comprising the drawing, such as copper ink, would be used to evoke a sense of the material entropy that would normally occur only in a completed construction. The drawing, just as a building, was a construction with all of the attributes one might find in a building.

Eventually, the computer with its considerable capacity for storing, replicating, and transforming visual information, enhanced the ability for Morphosis to use representation in a productive, experimental way. The subtraction of complex, three-dimensional voids from equally complex, three-dimensional solids—complexities that were previously almost indescribable—became relatively effortless. Not only does the computer permit the generation of these indescribable forms, but it facilitates the specific description of these forms directly to engineers and fabricators. The generation of actual three-dimensional models from many of these computer programs became an invaluable resource for the investigation of what Thom Mayne describes as “combinatory form,” a

strategy of design that relates not only to the architecture of a building, but brings to the architecture of a city the intricacies of aggregate forms that normally accrue only over time.

Often, after its design process has ended, Morphosis would rerepresent a project in a type of critical autopsy, an attempt to identify and further mine the potentials of its strategies. In other words, representation in various media becomes a creative, vital, and organic process that leads both to the development of a design and the speculative exploration of a project's extended possibilities. For Morphosis, representation is the architect's principal experience of a building.



Left: Mies van der Rohe's drawing of 1920-21 project for a glass skyscraper uses charcoal to study the primary architecture concept of a tower that celebrates the reflective properties of glass. The strong, almost primitive, thrusts of charcoal produce the distinct vertical patterns of light created by the tower's faceted surface.

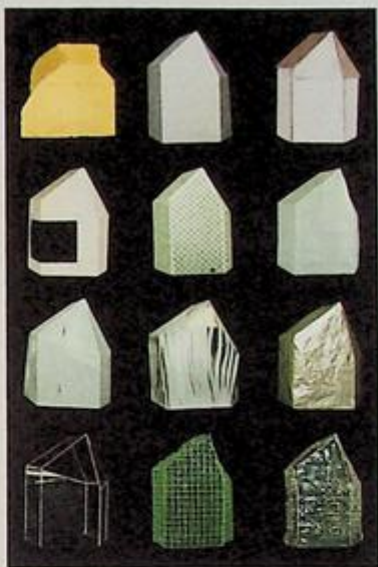

Right: This series of Herzog & de Meuron's model studies for the 2000 Prada Tokyo project in Aoyama, Tokyo, explores the perceptual relationship between the form and material. The relentless repetition of a standard form whose single variation is the material with which it is constructed facilitates the immediate testing of alternative material concepts.

line might establish the importance of a primary wall in defining the limits of the space or the surface of the ground from which a volume is emerging. It is the range and relationships of these lines within a drawing that can establish the complex contextual, spatial, proportional, and dimensional relationships that are embedded within the development of an architectural concept.

Physical models made from paper or cardboard have the ability to explore volumetric and spatial relationships and depending on their scale focus on one or two salient concepts with which the work is being developed. Due to the ease with which they are constructed, they can be rapidly transformed, and even intentionally misread. They can *infer* materiality through the dimension and deployment of their components—thick suggesting material massive (i.e., concrete or stone) and frame suggesting repetitive thin (i.e., steel or wood) but remain abstract representations of three-dimensional

constructions. Freed from material specificity, they can suggest fluid conceptual associations between unlike materials but whose properties encompass similar characteristics—as a building's walls are an extension of the ground on which it sits.

Models constructed of more permanent materials such as plaster, wood, metal, or glass can explore both the perceptual and physical behaviors unique to a particular material's composition and fabrication practices. Plaster castings privilege the study of architectural space as the models necessitate the literal construction of the space as formwork for the actual production of the model. A steel model, on the other hand, might be more concerned with exploring the qualities of a concept that is informed by a component system—one that is additive or layered—where repetition and jointure becomes a critical part of the development of the concept.



This conceptual model for Diller Scofidio's 1991 Slow House is an apparatus for vision. Building sections are drawn onto glass slides that are incrementally inscribed into the body of the house. Here, the reverse perspective form of the wooden mass that connects the carpet to the

ocean beyond is interrupted by a series of flattened glass layers. Two distinct forms of vision are simultaneously demonstrated: one a series of reiterative and flattened spatial layers, the other a perspectival (albeit reverse) cone of vision.

In Ben van Berkel and Caroline Bos of UNStudio's drawings for the 1998-2008 Music Faculty in Graz, Austria, surface continuity is overlaid with serial repetition to provide the fundamental spatial and structural tools that can be subsequently morphed and transformed to produce spatial composition as a function of programmatic specificity.

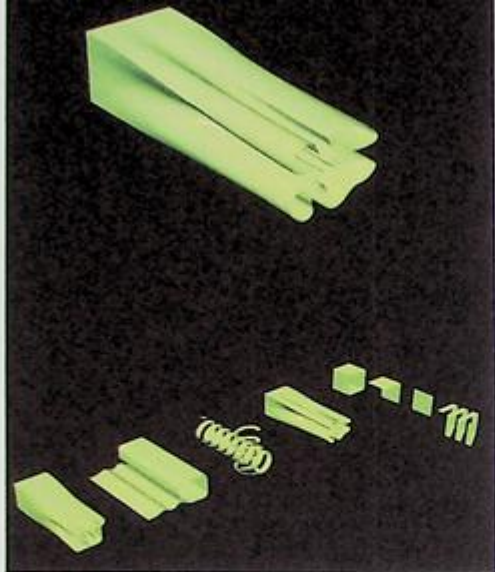

J. Mayer H.'s Metropol Parasol in Seville, Spain, (2004-2011), is an archaeological museum, a farmers market, an elevated plaza, multiple bars and restaurants, and a panoramic terrace—spaces that are all derived from what appears to

be a single primitive increment that is subsequently multiplied, informed, and transformed by the parameters established by the fusing of a bonded timber structure with extreme ranges of programs, scales, and relationships to gravity.

### Digital

The computer enables alternate modes of representation through 2-D and 3-D CAD software programs. And as with analog, digital drawings are constructed—but unlike the analog, the construction of the digital image does not evolve as a continuous operation. Instead, it is a process of introducing layers of information that, as with a cadaver, are subsequently operated on—operations that might include dissection or accretion, addition or subtraction, repetition and variation, forming and deforming, lofting or booleaning, and so on. More sophisticated computational processes deploy the computer as a generative tool—shifting its role from representing and/or transforming existing form to *making* form. Establishing a set of specific constraints and behaviors can generate complex forms and performative behaviors and relationships that subsequently allow for the interactive testing of alternatives within a context of both physical and behavioral environments.

Software programs such as AutoCAD require the use of an inventory of line weights to create hierarchical differentiation. If this differentiation in the analog is developed through the processes of drawing, with the computer the weight (i.e., significance) assigned to each line must be determined a priori. In other words, a certain knowledge or intention is required.

Computational processes often deploy geometric primitives that are subsequently iterated, repeated, transformed, informed, deformed, and reformed to produce architectural form. The data that motivates these procedural transformations of the primitive can be informed by a broad range of criteria (structural, performative, ecological, and so on). The resulting architectural vocabulary is one that often registers these aggregations of morphing, transforming, and accreting primitives. Here, the architect is no longer the maker, *per se*, but the choreographer of processes that *result* in architectural form.

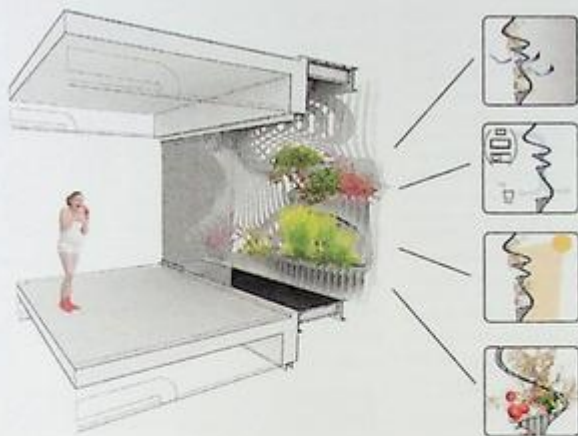

Professor Dana Cupkova's 2009 Adaptive Component Seminar at Cornell University asks students to explore the development of a component system whose individual parts adapt to localized programmatic, structural and climatic criteria. These incrementally adaptive

responses generate complex geometries that are subsequently fabricated by digitally controlled tools. The resulting aggregated forms express the performance parameters. The EatMe Wall project, shown here, (D. Cupkova, M. Freundt, A. Heumann, W. Jewell,

D. Quesada Lombo, D. Wake) is designed as an interdependent garden wall/gray water filtration system/shading system/ventilator, one that provides expanded space for the building to which it is attached.

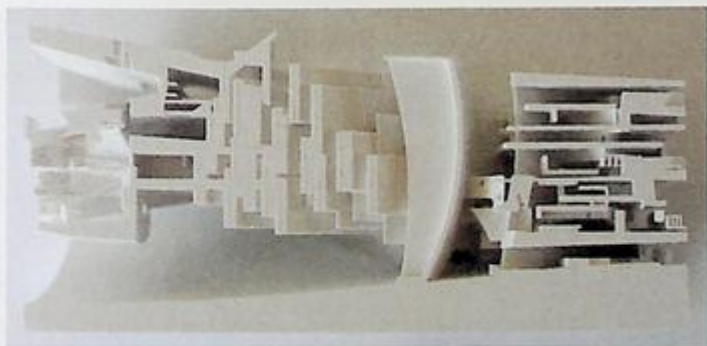

In these study models—for an addition to the Stockholm Public Library (by student Natalie Kwee in Yal Warke's 2011 design studio at Cornell)—the 3-D printer uses digital information to produce highly complex combinations of forms that

exceed the normal graphic and modeling capabilities of standard analog techniques. Digital programs, such as Rhino, facilitate both the addition and subtraction of compound forms, and then instruct the 3-D printer to generate models of these

forms. These models give the designer the freedom to study form from a virtually infinite number of perspectives and facilitate the study of form as a function of its environmental, perceptual, and physical contexts.

Computer applications can be directed to program a wide range of machinery that operates in very distinctive ways. Some use a laser to cut thin layers of material that can subsequently be assembled into three-dimensional models (laser cutter). Others use drills to remove or excavate material from an existing material mass (CNC mill), and still others aggregate lightweight granular material via a series of successive layers to produce an essentially homogenous three-dimensional object (3-D printer). Each of these fabrication processes is allied to conceptual strategies that can be uniquely explored through the technological constraints of the machine and its corresponding software.

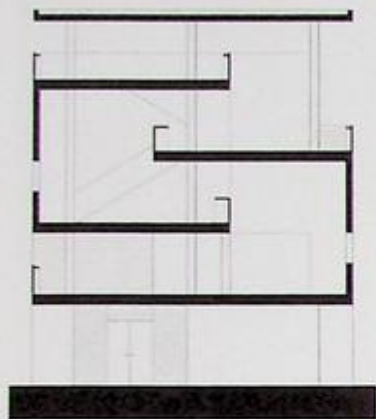

Referred to as the classic Carthage section, Le Corbusier's section for the 1927 Villa at Carthage shows a series of interlocking spaces. It is perhaps the clearest example of Le Corbusier's concept of the "long dimension," the notion of expanding spaces by

always opening up diagonal vistas in plan and, in this case, in section. Within each space, one is simultaneously occupying at least three spaces: the space that one is physically occupying is spatially overlapping with those above and below.

## Typologies of Representation

Architectural representation facilitates the examination and expression of architectural thought as filtered through the unique conventions that are embedded within a particular type of representation.

### Plans

Plans are drawings that reveal the relationship of surfaces and volumes in space. They are horizontal cuts through space, typically taken at eye level looking down into the space. In a series of essays originally published in *L'Esprit Nouveau* in 1921 and subsequently collected in *Toward an Architecture*, Le Corbusier writes: "The plan is the generator. Without a plan, you have lack of order, and willfulness. The plan holds in itself the essence of sensation ..." For with Le Corbusier, one arrived at the third dimension *not through the construction of an image* but as the result of the transformation of the plan into mass, space, and surface. The plan is an architectural abstraction within which are embedded the geometric principles of the structure that rises above it.

### Sections

Sections are vertical cuts taken through space. They primarily concern themselves with establishing a space's relationship to both ground plane and to other spaces, and infer movement between those spaces.

### Elevations

Elevations allow one to describe the vertical surface. They are useful for studying the interface between two unlike conditions (as between an inside and an outside, or a public and a private, or a large space and series of smaller spaces).

### Axonometrics

Axonometrics are drawings that represent the third dimension. They are measurable drawings that allow one to study multiple surfaces of a volume simultaneously. They are often used to represent architecture as a single object or as a collection of objects.

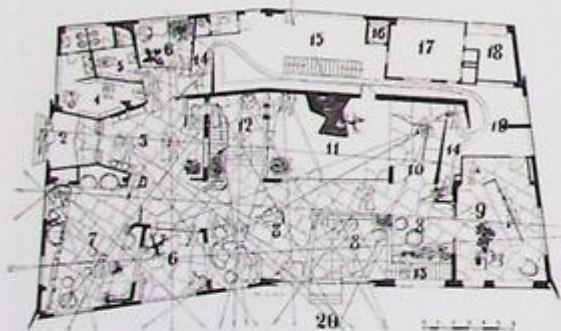

Gio Ponti's view diagrams for his 1953-57 Villa Planchart in Caracas, Venezuela, generate the three-dimensional concept for the house as a series of intersecting perspectives. As Ponti wrote in his

February 1961 article in *Domus*, #375: "... it is a 'machine' or, if you will, an abstract sculpture on a massive scale, not to be viewed from outside but [experienced] from within,

penetrating it and moving through it. It is made to be observed by a continuously moving eye. But this building is not made only for the eye; it is made for the life of its inhabitants ..."

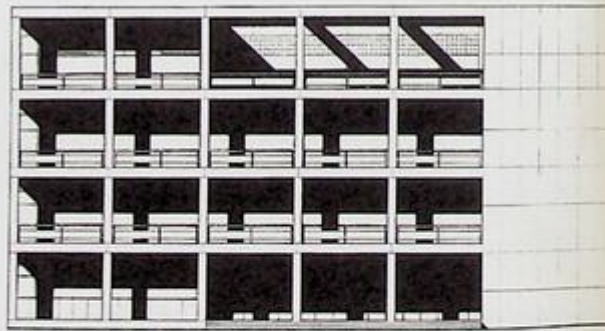

The underlying frame of the front entry elevation of Giuseppe Terragni's 1932 Casa del Fascio (now Casa del Popolo) in Como, Italy, undergoes a series of transformations that mediate the divergent scales and

programs on either side of it. The frame is suppressed as it is transformed into billboard for projected texts and images viewed from the adjacent cathedral square. It is transformed into deep portico as it expresses the

transparency of entry and the primary interior gathering space beyond. And it becomes a more intimately scaled balcony as it slides in front of the slightly recessed offices and meeting rooms within.



Aldo Rossi's 1971 competition drawing (with G. Braghieri) for the cemetery of San Cataldo in Modena, Italy, is a frontal axonometric/perspective. Here, the combining and flattening of both walls and roof surfaces within the drawing produces a series of spatial layers that reinforce the processional nature of the complex, emphasizing the status of the iconic objects that populate the interstitial layers. The density of the drawing presents the cemetery as an extension of the city beyond—a city of the dead.

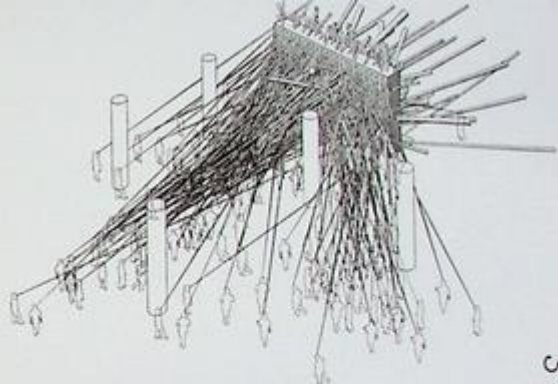

Vision is the generator of the design concept as is demonstrated in this axonometric study of LTL's Memorial Sloane-Kettering Cancer Center Lobby 2005

wall in New York City. A series of view cones becomes the operational device that is registered onto and subsequently excavated within the mass of the wall.

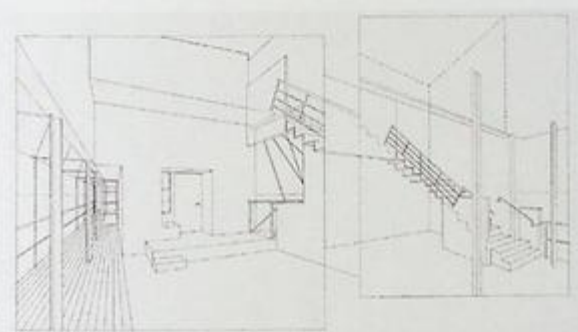

Steven Holl's drawings for the 1988 Cleveland House in Cleveland, Ohio, literally

unwrap the experience of ascending the stair that lines the entry vestibule, inscribing

the vertical sequence as a series of interconnected perspective views.



Preston Scott Cohen's 1994 "model" for a competition proposal for a Head Start Facility emerges from a two-dimensional field of perspective drawings. An initial volume is transformed

by a continuous representational loop as perspectival drawings of the volume are re-embedded within it, which is subsequently redrawn as a fused entity. The distinctions between drawing and model

and of surface and mass are blurred into a folded volume that constantly shifts between two and three dimensions.

### Perspectives

Perspective drawings tend to privilege the eye of the observer and what her or his experience might actually be from a particular point of view. While they create the illusion of three-dimensional depth, they can also be used to exaggerate the significance of a certain object or space through the convergence of lines toward one or more common vanishing points.

### Animations

Animations explore the temporal aspects of an architectural concept and the potential of a space or material to undergo transformation. They tend to be iterative drawings that can isolate a spatial sequence through which one is moving or a more ephemeral condition of light as it moves across a room.

### Hybrids

Hybrid drawings and models sample multiple representational typologies (plans, sections, or elevations) to superimpose concepts, materials, contexts, and scales that might otherwise be embodied by singular representational strategies. Through the combining of multiple representational typologies, the characteristics that are elucidated by one are combined with the other, facilitating an aggregate conceptual richness.

Accommodating a program is more than solving a puzzle: It requires three-dimensional strategizing, an understanding of space, the addition of missing elements, and a *concept*.



# program

**Programs begin with measurements and expectations but mature with thoughtfulness and understanding, anticipation, and empathy.**

An architectural program is, in its most basic form, the list of requirements that initiates a project. Outlined by the client, often with the assistance of either an architect or a special consultant, this type of program generally represents a compromise between desire and budget. And although determined by the client, the client is not



Beginning with the Roman Empire, the freestanding arch conveyed a message of memorialized triumph. The Arch of Augustus outside Aosta, for example, connotes a first-century BCE victory over a Gaulish tribe. The nineteenth-century Arc de Triomphe in Paris, although originally programmed to commemorate Napoleon's victory at Austerlitz, has

continued to evolve in meaning and interpretation—as a monument of wartime victory (alternately by the French, the Germans, and the Allied troops), and as a monument to achieved peace. Its attic stories have been programmed to include associated museums, most recently one dedicated to the iconography of the arch itself.



necessarily the user. Even in the case of a house, it is unlikely that a client would forever be the only occupant.

In schools of architecture, the program may resemble a client-generated program, but it inevitably encompasses specific pedagogic objectives. The studio instructor usually generates such programs, with stated requirements serving as vehicles for achieving these objectives.

But despite the apparent clarity a program suggests, accommodating a program is more than solving a puzzle: It requires three-dimensional strategizing, an understanding of space, the addition of missing elements, and a concept. Further, many programs tend to include contradictory requirements that need to be resolved through some form of negotiation or innovation.

### The Empirical Program

The empirical aspect of a program can be derived from charts, tables, and direct measurements: in general, observations of the way things are. The data that contributes to the empirical program are basically dimensional, functional, relational, and measurements determined by building and safety codes.

#### *Dimensional*

There are certain dimensions that can be taken for granted and that must be recognized when compiling a program. The most fundamental of these dimensional imperatives is the accommodation of the human body.

The architect should be aware of the kinds of bodies that will occupy a building. The average adult tends to conform to a range

of dimensions concerning height, grasp, eye level, and the variable dimensions related to the body while sitting, leaning, or reclining. These dimensions differ considerably in the case of children from infancy toward adulthood. Additional dimensions should be taken into account for the accommodation of those in wheelchairs, those with special physical requirements, and the innumerable nonaverage adults.

Foremost in all of these cases are those dimensions that permit someone to move comfortably through space: hall and aisle widths, ceiling heights, the angles and lengths of stairs and ramps, as well as the suitable arcs and angles that permit the unimpeded operation of doors, windows, and other moving elements.

(continued on page 41)

# Program as Tactical Device: Rem Koolhaas and the Office for Metropolitan Architecture

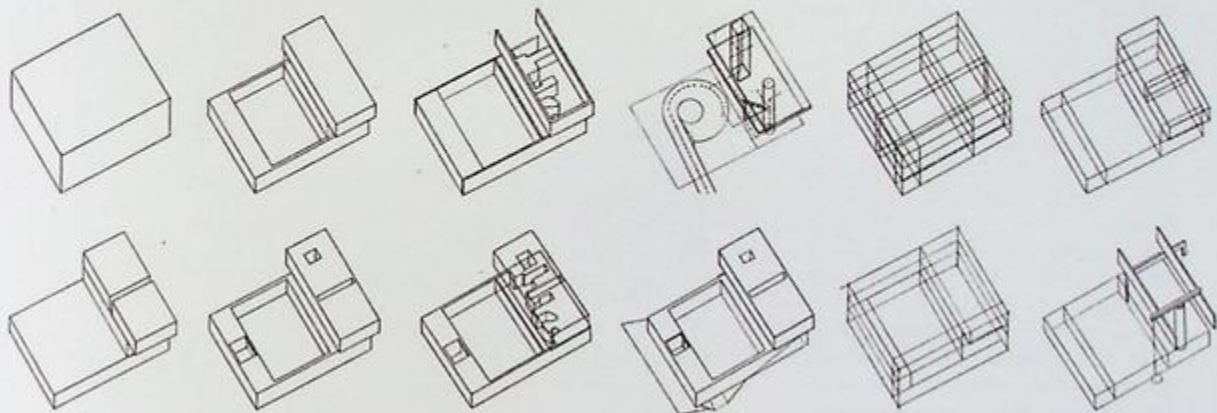

Bordeaux House, exploded axonometric sketch

It can be argued that the fundamental motivations guiding the work of OMA include a relentless reconceptualization of the modernist project, an opportunistic attentiveness to the intricacies and forces of formal and cultural-political contexts, and persistent exploration of the grammar-syntax-language intersection. However, the most essential act of invention and intellectual rigor is asserted through OMA's description, organization, distribution, and theorization of what we call *program*. With *program*, Rem Koolhaas—and earlier, Elia Zenghelis—construct a conceptual framework for making function and use *architectural*, and against which all context-based and culture-specific experimentation is understood.

The Bordeaux House addresses a unique domestic program assignment by producing a courtyard house on a sloping site, organized into three horizontal slabs of associated functions. The result is a layered sandwich of program elements manifesting as a heavy floating house for sleeping in the sky, a *light* house carved in the ground for cooking and access, and an *invisible* glass house for living and leisure compressed between the two—each element self-sufficient and composed according to its own programmatic logic. Within this structured subdivision of program are rituals and sequences that penetrate and actuate the horizontal separations. The first is the domestic realm of the father—a wheelchair

user—with specific practical and customary needs: His program centers on a piston-driven elevator that serves a vertical house comprising an office, library, living, dining, sleeping, and wine cellar. This elevator is a moving room, providing access while fusing with the functional conditions it engages on each floor, producing a temporal alteration of activity that conflates functions with users. The three daughters occupy a private sanctum within the compound's levitated red box, achieved by slicing the entire composition along the longitudinal axis, bifurcating the house into two halves: parents and daughters. The father's elevator is countered by a spiraling stair in a mirrored cylinder that serves only

the girls' bedrooms, linking them from the entry "cave" in the ground to pinwheeling bedrooms in the sky.

In their project for the Kunsthall in Rotterdam (1992), OMA was challenged to satisfy a complex set of functional requirements including three independently accessible galleries, an auditorium, external café, administration, storage, smaller galleries, and service components. The scheme assumes the form of a square penetrated by a continuous exterior ramp facilitating the connection between the boulevard and Museum Park. A second passage, positioned below and perpendicular to the public passage, allows for vehicular service access. These crossing paths produce a square cut into four distinct, disconnected volumes. The resulting circulatory experience is conceived as a circuit of sloping floors and ramps crafted into episodic twists, turns, and counterintuitive movements that ultimately connect each part of the complicated sequence, suturing parts fragmented by their initial functional assignments, producing access and orientation along the way.

OMA understands the inherent value of addressing architectural program, of embracing functional requirements to help advance the intellectual and performative basis for their work. They consistently perform complex acts of functional elasticity whereby the edges, names, and restrictions associated with typical functional limits are tested and teased, allowing for the intermingling and co-occupation of otherwise disparate programmatic elements.

—Richard Rosa II (Syracuse University)

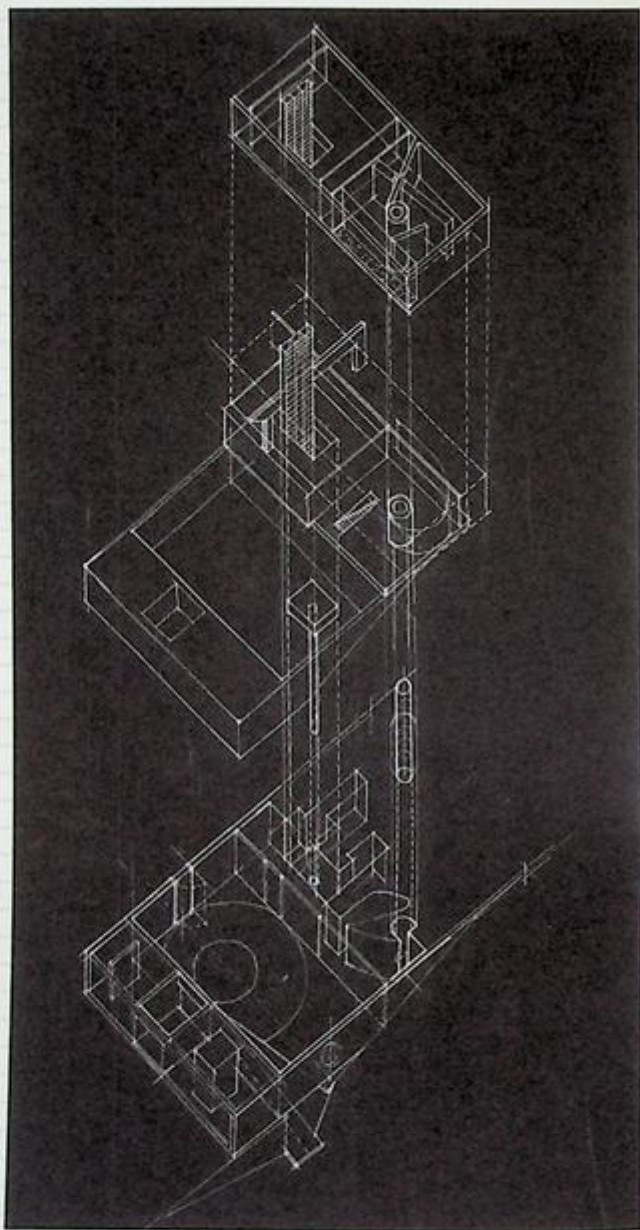

Kunsthall, north-south and east-west sections  
Rotterdam, 1992



The dimensions required of certain *furnishings* must also be considered when developing a program. This is true not only of the obvious furnishings one might encounter—for example, a single bed not only occupies a very different amount of floor area than a king-size bed, but the requisite areas surrounding each type of bed vary substantially—but also relates to specialized furnishings. A trophy collection, a library of 10,000 volumes, a classroom with thirty desks, or various medical treatment and imaging machines, to name a few, all have specific requirements for accommodation, access, and occasionally for security or safety enclosures.

In addition to the empirical data determined by the human body and by furnishings, one must also consider the accommodation of other specialized dimensions, such as those of various *vehicles*. Automobiles have a clear range of length, width, and height dimensions as well as ideal turning radii. Delivery trucks, however, inevitably require a completely different range of such dimensions, as well as suitable dimensions for loading docks or mechanical lifts.

Occasionally, even boats of various types must be accommodated, each with its own dimensions and docking requirements. Moreover, vehicles usually require special ventilation and fire enclosures.

Paradoxically, regardless of the people, furnishings, or vehicles one anticipates in a program, it is inevitable that *other* people, furnishings, or vehicles will need to be housed. People have children, age, develop permanent or temporary infirmities; there may be more or fewer of them to be accommodated during the building's lifespan. The motorcycle may be traded for a minivan. New medical advancements will require different equipment. A high school's athletic team might become exceptionally victorious, needing more room for practices and trophies; or the number of desks in each classroom may need to double or halve.

In other words, one should not put too much faith in the dimensional data one gathers while programming, to aim for the tightest fit. A loose fit is more likely to satisfy the vicissitudes that accompany the life of a building.

Parking garages have been among the most inflexible in their programming and functions, invariably optimized for the accommodation of automobiles: access ramps, turning radii, dimensional parking spaces, lack of obstructions, utilitarian pedestrian sequences, and vertical structure that is burly and repetitive. One of a new series of parking structures in Miami, the garage at 1111 Lincoln Road by Herzog and de Meuron (2005–08) uses

irregular floor plates (irregular in plan and section, with some ceilings exceptionally high for a typical parking facility), discontinuous structure, and a number of intermittently placed supplemental functions (such as shops, restaurants, and an "event" space often used for product unveilings and weddings) to produce a continuously changing sequence of episodes connected by a grand, cascading pedestrian stair.

*Functional*

There are few reasons for an architectural design to fail to meet its basic functional requirements—to perform as it is required—as long as those requirements are clearly defined and there are the technical, material, and budgetary means to accomplish them. *Functionality* is the extent to which the design is able to perform its tasks. Thoughtful programmatic development can enhance the functionality of a design.

A musical rehearsal room, for example, might require specific acoustic characteristics—depending on the instruments that use the space,—as well as be isolated from other performance spaces. Most classrooms benefit from significant exposure to regulated daylight and some even with direct access to an exterior space. Other rooms, however, especially those that deal with various controlled media—such as projections and computing—or light sensitive materials may require an easily darkened space, or one with no direct sunlight.

Often, a program will require a multi-functional space, or the designer may decide that several requirements can be simultaneously accommodated by merging spaces and their functions, especially if these usages might occur at different times of the day or different seasons of the year. In designing multi-functional spaces, however, the architect must be certain that the space is ideal for each of the separate functions. It is often the case that such spaces, in their aspirations for flexibility, eventually serve no function very well.

*Relational*

A program should also note those elements that usually require direct proximity, such as pantries and kitchens or kitchens and dining spaces. Lobbies tend to be near entries, for example, which should in turn be near



The program for Alexander Brodsky's Pavilion for Vodka Ceremonies (2004) at the Kiyazma Reservoir near Moscow required the design of both a pavilion and a ceremony. Just as the reservoir is a retreat for Muscovites, the pavilion is constructed of windows salvaged from a factory in the city. The whitewashed mélange of windows suggests a typical rural shed. In single

file, two people mount the precipitous stairs and pass through the narrow doors. Within the unheated pavilion (vodka should be near frozen), the participants stand on opposite sides of a simple wooden table and dip tin cups—attached to the table with very short chains—into a basin of vodka. They toast each other with modest, slightly stooped postures. The ceremony's conclusion is indeterminate.



vehicular access. While loading docks inevitably require proximity to a road or driveway, they are rarely positioned in the most publicly viewed faces of a building. The notion of arranging elements by proximity is based on the optimization of usage or, occasionally, of expense. For example, spaces requiring plumbing are famously arranged close to each other, often back to back and vertically stacked, so that the expenses of construction and repair are minimized.

*Orientation* is also important in determining programmatic relations. A painting studio may prefer north light, whereas a breakfast room is best complemented with light from the east. One may decide that public spaces, such as living and dining spaces, or waiting rooms and theater lobbies, should be oriented toward a preferred view. Obviously, solar collectors inevitably have a preferred orientation, and so their location must be determined by the

maximum availability of sunlight. Prevailing winds might be considered for the sake of passive ventilation.

#### Codes

Building codes, including safety, zoning, construction, and even esthetic codes, can have a major influence on a program. These codes are generally determined by municipal, state, and national bodies. Codes can determine everything from the required distances from property lines to the maximum building volume with setbacks, from the widths of corridors to the numbers of fire exits, from the types of materials that can be used between spaces to the percentage of a wall that is permitted to have windows, from the types of steel that can be used to the performance requirements of that steel. Some codes even determine the color, style, and exterior materials that are permitted when building in a specific location.

In 1792, John Soane began purchasing and then heavily renovating a row of townhouses and stables on Lincoln's Inn Fields in London. While the program for his manipulations was ostensibly that of a large urban residence, Soane, architect of the Bank of England and other great structures, saw his house as serving a didactic function: it was a continuously evolving

laboratory for his architectural investigations as well an educational environment for his sons, for whom he hoped architectural careers. Unfortunately, his surviving sons developed apathy for architecture and a distaste for their father's architecture, in particular. He willed his house to the nation, and it is now known as Sir John Soane's Museum.

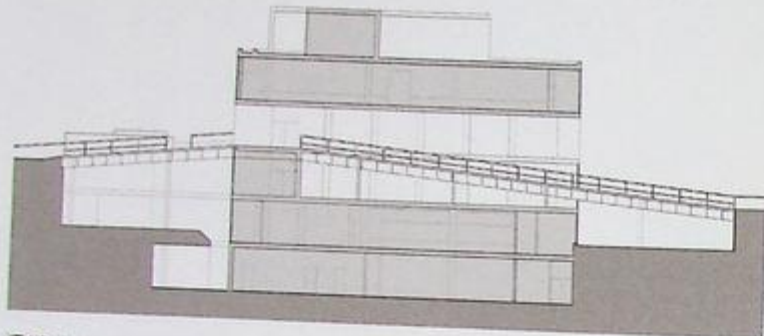

When Le Corbusier was brought in to design the Carpenter Center for the Visual Arts at Harvard University, the program called for exhibition spaces, studios, a lecture/theater space, offices, and, later, an apartment for a visiting artist. The

building, completed in 1963, introduced a ramp that drew pedestrians from the bounding streets and upward through the heart of the building. With the ramp and its accompanying spaces, Le Corbusier introduces a significant addition to the

program: the public is invited to observe both the artworks and their production in what is essentially an academic building turned inside out, inaugurating a new academic program in the midst of a traditional campus environment.

Building codes can guard the safety and the living qualities of those who use a building as well as those neighbors who might be affected by the effects of a construction as it alters an environment: its shadows, its emissions, its traffic patterns, and so on. The designer who understands these codes during the programming stage will immediately know the range of a project's possibilities and will be able to make decisions that benefit from the accumulated knowledge of experiments, experiences, and examples. (Overly restrictive codes, however, may permit only predetermined design solutions, a replication of set ideas, and prevent innovations that may be beneficial to a group of users, a society, or an environment.)

### The Innovative Program

Jerzy Soltau, once a colleague of Le Corbusier, and later a professor at Harvard's Graduate School of Design, succinctly observed, "It seems the concept of the program is so often, too often, accepted by the designer passively. The relations between programming and designing constitute often the most painful part of the process in the birth of a building. Le Corbusier coined the famous phrase: 'to design well, you need talent; to make a beautiful program, you need genius.'" ("Architecture 1967-1974," in *Harvard GSD's Student Works 5*)

Great works of architecture inevitably transcend the simple empirical data of a program, introducing elements and relationships that can bring more to a building than a simple resolution of its fundamental requirements: it can inspire its users and address audiences beyond its boundaries, accommodate unimagined futures, and improve its environment both physically and experientially.

## Empathy

The eighteenth-century architect Claude-Nicolas Ledoux, wrote in his treatise on architecture that "the role of the client is to express his needs, often badly. The role of the architect is to rectify those needs." While this may seem to be somewhat dismissive of the role of the client, Ledoux underscores the fact that, unlike the client who may be aware of only a confined set of forms and ideas, the architect must be aware of the world beyond that of the client, of the potential users and of the conceivable future of a project. Ledoux often had the French monarchy as his client, but in the case of his Royal Saltworks, for example, the users were an entire city of managers, workers, and their families. Today, when designing a school, a school district may be the client, but the users are the teachers and students, the

cafeteria workers and janitors. The architect must be able to empathize with those potential users of a work, to try to see through the eyes of others.

An architect should be able to grasp cultural and economic differences, to discover the techniques with which a blind man senses his environment, the ways a child with mental disabilities perceives her daily rituals, the conditions in which a senior citizen might wish to engage a community, or the importance of the family dinner within certain cultural groups. All of these understandings can lead to modifications of a program. No two individuals can have the same experiences, but the architect is obliged to try to understand the best means of empathizing with a user, in order to initiate a productive and gratifying dialogue.

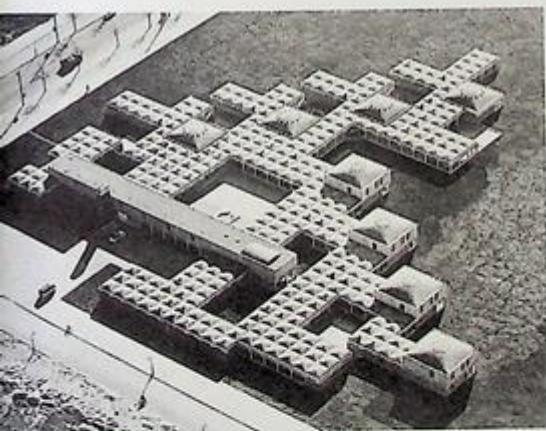

A municipal orphanage on the outskirts of Amsterdam provided the ideal program for Aldo van Eyck, whose interests involved the relationship of architecture to community and of the

humanist aspects of the city—markets, streets, and squares—as they might correspond to the design of a building. The building, completed in 1961, is composed of an aggregation

of concrete modules containing interior public spaces while encircling a sequence of exterior courtyards. From above, the building reveals its village-like organization, with

neighborhoods centered on domed volumes accommodating residential, living, and classroom spaces for each age and gender group. Despite its overall diagrammatic precision, its components—

benches, door stoops, archways, and ledges—respond to the scale of its young residents, with mirrors and windows placed in unexpected places and nearly invisible to adults. Van Eyck's

orphanage introduced open, unassigned, semiurban spaces as well as transitional niches and nooks to a building program that usually values efficiency over vitality.



The Spanish Steps were designed by the architect Francesco de Sanctis, possibly in collaboration with the papal architect Alessandro Specchi after more than 125 years of debate over how to connect the Piazza di Spagna to the church of the Trinità dei Monti, located at the top of a steep slope. While programmed as just a stair, the Spanish Steps function as a vertical urban garden, a market, a place to rest, a viewing platform, and seating for spectators.



#### *Hybridization*

Some of the more innovative programmatic manipulations come from the combination of customarily isolated programmatic elements. For example, while shopkeepers often lived above or behind their shops, this tradition has been abandoned in favor of planning that separates commercial from residential programs, especially in modern cities. This results in districts that exhibit little life outside a few circumscribed hours each day.

The hybridization of programmatic elements can lead to a constantly reinvigorated environment, where unanticipated juxtapositions can inspire unexpected and unimagined thoughts and activities. The combinations of a children's library with a secret garden, an art school with a public passageway, an advertising agency with a billiard parlor, a

senior citizen's center with a cooking school, maybe even of a bowling alley with an art gallery, all serve to bring the potential for provocative experiences to normally restricted programs.

When human behavior is unconstrained by singular and proscribed roles, when a program blurs the distinctions between one or more functions, humans tend to expand the range of their observations and to innovate new behaviors.

#### *Limitations as Advantages*

Every program establishes a set of limits. Far from being deterrents to the design process, these limits are occasionally the sites of genuine architectural innovation. For example, the necessity for using only locally available materials—pine, bamboo, or

clay—may initiate an inventive use of these materials that can have implications well beyond the development of a single project. The unique cultural composition of a neighborhood may suggest relationships between previously ignored programmatic elements, like the use of a garage as an exterior dining space.

Some of the most inventive architectural works are originating from studies of areas with very limited material and economic resources, such as some of the “informal cities” that have grown surreptitiously (and, often, illegally) in the almost inaccessible centers and edges of many of the world’s most dense urban environments. The design

of public transportation, day care, community, and educational facilities in these neighborhoods has provided designers with considerable challenges but has resulted in some of the more inspirational productions in contemporary architecture.

Jerzy Soltan, in the essay cited previously, goes on to add his own interpretation to Le Corbusier’s words, “But good programming is related to a broad and deep attitude toward the whole world, and life, real and dreamed.” Programs may begin with measurements and expectations but will mature only with thoughtfulness and understanding, anticipation and empathy.

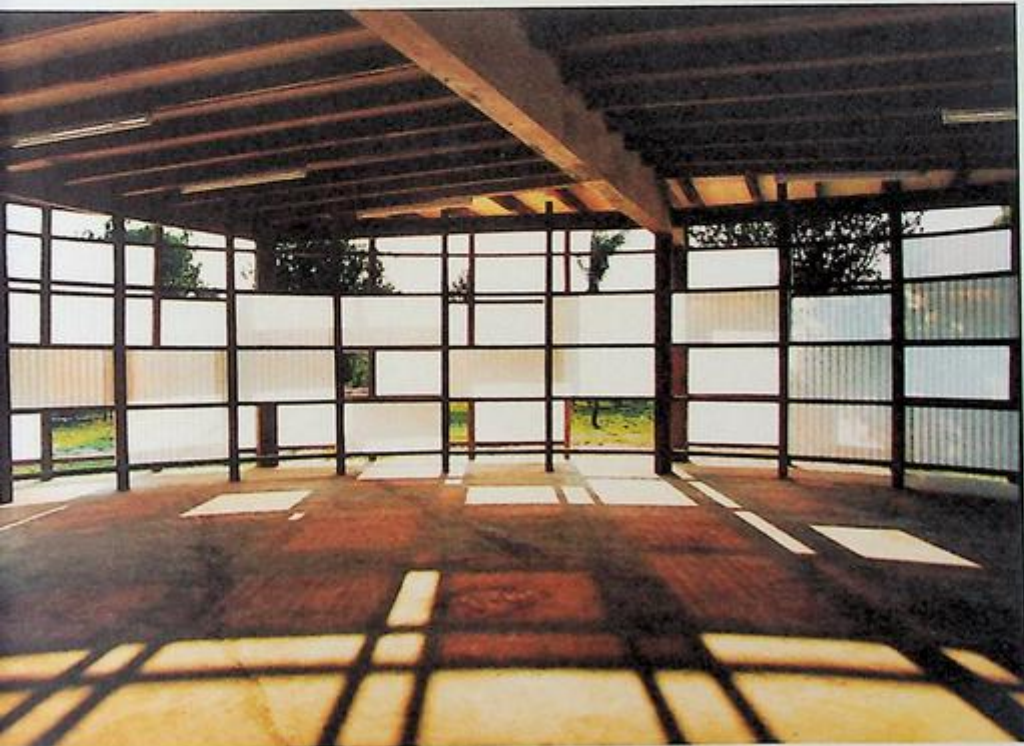

In Urubo, a small village in Bolivia, Jae Cha designed a small building to be composed of locally harvested wood and translucent polycarbonate sheets. Once designed, the community built the structure in just ten days. Although programmatically a church, the building’s plan—a circle within a circle—is a form that fundamentally evokes the notion of gathering, indicating its capacity to function as a more general type of communal gathering space. With its luminous wall surfaces lending the structure a sense of lightness and spirituality, the church at Urubo (2000) is a beacon of assembly and both the religious and civic nucleus of the village.

Every architectural work exists in the presence of a chorus of contexts that can impart meanings to and, in turn, derive meanings from their associations with the work.



# context

**While a context can be measurable, it is also always malleable.**

A work never exists in isolation. There is always a context in which it is situated, and in which a relationship to that context is established. And while that relationship can be platonic, casual, symbiotic, or detrimental, it is the specifics of that context and the ways in which it is interpreted that establish the terms



A composite building that evolved and expanded over 600 years, the Vienna Hofburg had an extended conversation with its surrounding context. It not only alternates between

forming streets and squares as it sidles up to existing linear edges and as it completes fragmented urban spaces, but creates a previously illegible axis as it constructs backdrops that

terminate them. It fuses itself with its context, it is an architectural chameleon that appropriates, blurs, and produces its urban boundaries.



Through its single columned portico the Einar Jonsson House (Reykjavik, Iceland, 1916) establishes a monumental presence when



viewed from the city below. However, its opposite side addresses what was planned to be an intimately scaled public space embedded

within a residential neighborhood. The design of the house thus inspired the scales and proportions of the city as it developed around it.



At the Center for the Advancement of Public Action completed in 2011 for Bennington College in Bennington, Vermont, Tod Williams and Billie Tsien used reclaimed marble from now

extinct local quarries to develop a material dialogue with many of the civic structures that populate the villages and towns of Vermont.

of dialogue. For one project, it might be the physical context that emerges as the most pressing voice to engage, for another it might be the infrastructural, for yet another it might be the ephemeral or the environmental. The dialogue can be one of friendship or of foe, one of accomplice or of exploitation, one of exaggeration or of disregard, one of exposure or of obfuscation. Yet, ultimately, a work has the ability to give meaning to a context, to encompass all that already exists within that context and the opportunity to inflect previously unknown contexts.

### Physical Context

Within any site there are the physical 'givens' that bring unique identity to the context in which a work is to be situated. They can also be strong factors in motivating the concept of that work. Existing structures have specific dimensional and spatial characteristics (heights, widths, openings, volumes), and material and construction methodologies. Natural and artificial topographies (flat or sloped, soft or hard) can be powerful determinants in establishing a building's relationship to its site, and views from and to the site bring an expanded identity to a specific context. Yet, while these 'givens' are measurable, they are often malleable, as a work can either emphasize or deemphasize their significance through what it chooses to call attention to.

### Material

Material can establish a context for a work. If one is to build a house in a town of wooden houses, perhaps one might build it out of wood. Or perhaps the material context might be a particular species of wood in a local forest, or the granite of a nearby quarry. Or, inversely it might be thought of as an extension of the ground on which it is constructed—as in a stone house situated on a rocky outcropping. Or perhaps it will be made out of brick to refer to an abandoned brick factory whose very existence created the town. In other words, a material context is an expansive one.

### Scale

Within a context there are two aspects of scale that need to be addressed. One is the scale of the site: a building in the middle of the city will be affected by the scale of the neighborhood—whether it is embedded in a block or surrounded by skyscrapers—or by the scale of the landscape in which it is situated (a vast plain or a dense forest). Then there is the scale of perception—the distant views from which one will perceive the building and the views that will be perceived from the building.

(continued on page 53)

# Álvaro Siza, Site-Seeing

If the engagement of a context is one of a work's most powerful forms of dialogue—the intimate, meaningful contact between a condition and a proposition—the works of the Portuguese architect Álvaro Siza Vieira are some of architecture's most articulate communications. Siza has developed a practice in which his buildings seem to gather both natural and man-made contexts into virtuoso compositions that suggest they have always been integral features of their environments, even as those environments are constantly changing.

For example, the horizon is a recurring theme in Siza's earliest project, the Boa Nova Tea House in Leça da Palmeira. Highly controlled views define the building's various relationships to its contexts. The steps leading to the front door tell us of our proximity to the sea, of our position within the rocks, of the nature of the large, hovering roof that shelters the tea house. A long, low horizontal dormer in the entryway reiterates the ocean's always calm horizon while a tilted skylight directly above shows a piece of the sky, and another window below frames a contrasting view to the turbulent, rocky shore.

Later, the Galician Center of Contemporary Art is surrounded by important baroque structures, most notably a former monastery with its cascading gardens. While the museum's stone cladding recalls the granite of its neighbors, this stone is clearly cladding rather than stacked masonry, appearing at times to be suspended in the air and surprisingly thin. On its most public side, the museum's masses follow the edge of the street, their profiles subtly deforming, causing the building to continuously reshape itself, based on one's position



Boa Nova Tea House,  
Leça da Palmeira, Portugal, 1963

in the surrounding spaces. When approached from the neighboring school, the angled soffit and ramp seem to elongate the distance toward the monastery, making the historic structure appear to loom larger than it is. From the monastery, these same angles distort perspective in the opposite way, shortening the apparent length of the street and reducing the scale of the museum's volume. The regular grid of the stone cladding underscores the distortion of the surface. On the garden side, the museum's mass seems to be reduced, adapting to the scale of the former gardener's shed, and stepping downward until it becomes itself a garden wall.

The works of Álvaro Siza Vieira do not simply denote their contexts, but they observe, analyze, and even explain their surrounding conditions—connecting contexts that have dissolved into a past with those being discovered in an ever-new present. As Siza has said, "Architects don't invent anything; they transform reality." Working with the layers of realities found in a site, Siza manages to produce works that elaborate, expand, test, and inevitably alter our perceptions, demonstrating that even finished buildings are capable of continuously renewed and expanded dialogues with their contexts.



Galician Center of Contemporary Art,  
Santiago de Compostela, Spain, 1988-93

## Space

There are primarily two scales of spaces. A building exists within a network of public spaces, and how a building relates to these spaces can establish conditions of entry and orientation. And then there is the building's internal and sometimes private spatial network, whose circulation and access to air, light, and view are equally dependent on its relationship to those public spaces.

## Site

The natural site will have specific physical attributes as in impenetrable or porous, sloped or flat, irregular or even, permanent or temporary. It can also be a constructed site that operates as a surrogate ground (a block of buildings, a retaining wall). It can be a visual one—as in the views that are seen from the site. The dialogue established with these site conditions can initiate spatial complexities.

## Infrastructural Context

There are aspects of contexts that already have elaborate networks and systems embedded within them, some of which may be tapped into whereas others simply may have to be contended with. These can take the form of physical traces, as in archaeological or geological layers, or more formalized transportation and service infrastructures. It is the dialogue with these infrastructures that can locate a work within a specific context.

## Layers

Occasionally, a site has been previously occupied—an archeological palimpsest, layered with traces of what was once there over an extended period of time. One has to decide how, if at all, these sometimes physical and other times implied, traces of previous occupations are going to inform a subsequent layer. A museum built over a great roman ruin might be considered differently than a house built over an old ice shed. Similarly, the structure of a site can be the result of an even more distant set of geologic events that can subsequently provide insights as to its future evolution. The nature of this transformation and movement over time can inform an architecture that anticipates potential disasters.



Álvaro Leite Siza's Tolo House in Lugar das Carvalhinhas-Alvite, Portugal (2000-05) amplifies the steepness of site by hugging its surface as it cascades down its extreme embankment, a staircase that connects upper and lower circulation networks. The dwelling becomes a surrogate landscape within which and on which the occupants reside.



Peter Eisenman's City of Culture of Galicia (2001-11) references the city plan of nearby Santiago de Compostela, Spain, in producing a surrogate landscape that connects the rural topography with the urban center. The landscape is metaphorically inscribed by pedestrian "rivulets" that define the volumes of the complex's eight buildings.



The form of the View House by Johnston Marklee and Diego Arralgada Architects in Rosario, Argentina, develops in response to a perceptual and environmental engagement with context. A series of formal distortions solve

apparently contradictory desires to have privacy within a suburban context and yet establish framed views of the distant landscape. Direction of prevailing winds and angles of sunlight situate the house in its more ephemeral context.

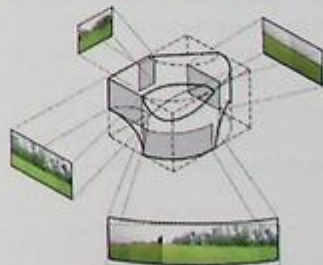

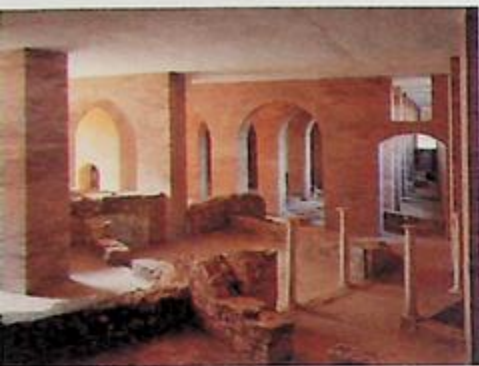

Referencing their Roman ancestors, Rafael Moneo's 1986 Museum for Roman Artifacts in Merida, Spain, overlays a series of load-bearing masonry walls onto the ruins of a first-century BCE Roman town and subsequently becomes the

new site for the display of the town's excavated objects. As with an archeological site, the geometry of the parallel walls registers the location of the excavated ruins onto which they are overlaid and through which they pass with abandon.

#### Networks

A building's relation to existing circulation and service networks has to do with suturing the various systems that would make a building a vital component of a larger network. Existing paths at multiple scales (pedestrian, automotive, bicycle, public transportation) may be pulled into the building to not only provide access but to be part of a larger whole. Access to various service elements such as water, air, sewage, and electricity can also provide parameters that inform a project's engagement with this expanded context.

#### Ephemeral Context

The idea of a Grand Prix being held in the city of Monaco or the Spirit Path at the Jongmyo Shrine in Seoul Korea where only spirits are allowed to walk are but two examples of the many invisible contexts that require a different form of investigation. Cultural traditions, narratives, and local histories are often embodied in the physical constructs that a culture produces.



In manufacturing a new site on the lake, Studio Granda's 1992 Town Hall in Reykjavik, Iceland, both collects existing paths and manufactures new ones that were previously unseen. Its resulting form becomes a civic collector, one that is reinvented seasonally and at multiple scales and

narratives. Its moss walls recall the flora and fauna of the sagas, its volumetric porosity an extension of its urban context, its circulation a walking route between two distinct neighborhoods and in winter it operates as staircase to the frozen lake.

The stepped water structures as documented by Klaus Herdeg in his portfolio of drawings that accompanied his 1967 exhibition *Formal Structure in Indian Architecture* are examples of how the rituals and customs embedded within a particular culture find expression in their architectural constructs.



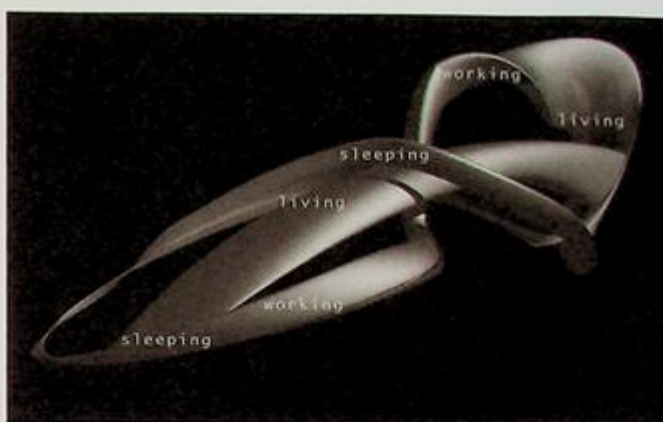

The fourteen chapels of the Sacro Monte located near Varese, Italy, and completed in 1623 contain scenes of the life of Christ, the Virgin Mary, and the saints. The chapel pavilions construct a pilgrimage path up the now sacred mountain that terminates in the church of Madonna del Monte. Each

pavilion establishes the spatial context for one of the important events of the life of Christ, and like the chapters in a narrative, each pavilion is situated in relation to its adjacent pavilions to produce a seamless spatial journey through the landscape.

#### Tradition

Rituals and traditions specific to a culture can be inscribed within a context. They can produce specific buildings or landmarks that mark an extended route along which the ritual occurs, or they can produce spaces within which cultural practices can be performed.

#### Narrative

Architecture has the ability to illustrate a story, one of legends and of wars or one of loves and of obsessions. A translation inevitably has to occur and it is in perceiving that translation that the work is able to address a user, and then it tells a story.



It is through the geometry of Ben van Berckel's 1993 Möbius House in Het Gooi, Netherlands, designed for a couple with two children, that the two independent and yet

intersecting domestic rituals of sleep, work and domestic life of the couple that inhabit it are spatially mapped within the volume of the house.

The red, pyramid-topped cones of Souto Moura's 2008 Casa das Histórias Paula Rego in Cascais, Portugal, reference both religious and secular contexts. By evoking both the kitchen chimney of the monastery at Alcobaca and the pointed turrets that dot the cityscape of nearby Sintra's National Palace, it situates and interprets the museum within multiple histories and contexts.



#### *Historical*

The reading of a historical context reveals what might have happened before on a particular site. It can connect a series of events that might have occurred in vastly different time periods. And even though it may not be physically present, a historical context continues to be alive in the memories of the citizens.

#### **Environmental Context**

One of the most important and pressing aspects of the design of a structure is its environmental context, a context that can either affect the building positively (as provide warmth or shade) or extremely negatively (as in erosion or collapse). Most characteristic of this context is that it is continuously transforming, either in predictable or unanticipated ways. And the building in turn has a responsibility toward that context: perhaps at worst it will coexist, but at best it will enhance it.

#### *Extreme Variability*

Architecture has a responsibility to anticipate that the environment in which it is situated will change, and often in quite unpredictable ways. Extreme weather—floods, earthquakes, hurricanes, and avalanches—introduce design parameters that situate a work in a specific environmental context. A building erected in a flood plain might be raised on stilts while one in a frequent avalanche zone might be wedge shaped and embedded into the mountainside.

#### *Weather*

Rates of environmental change can be more predictable, from a twenty-four-hour cycle to seasonal variations. A building's anticipation of the behaviors of basic yet constantly changing environmental elements of sun, rain, and wind cannot only be traced in the placement and dimension of apertures, the slopes of roofs, and the materials used, but in the more fundamental placement of a building within its actual physical site.



Constructed over 4,000 years ago, sunken courtyards dot the landscape of Henan province. These ingenious dwellings not only take advantage of the relative constant temperature of the earth to keep them cool in the summer and warm in the winter but free up the ground plane for agricultural fields.



Atelier Bow Wow's 2008 Double Chimney House in Nagano, Japan, reflects the firm's belief that architecture should express the behaviors of its occupants and the inherent elements of the environment in which it is constructed. Here the house is split open into two halves, permanently registering both its program (one side for guests, the other for the owner) and its environment, as the house carefully situates itself amongst the trees, opening itself up to the southern light.

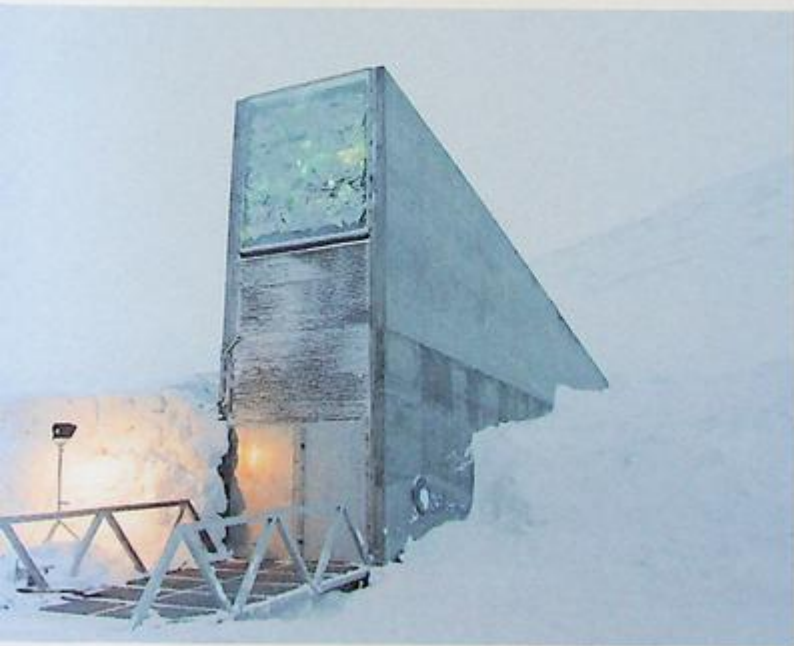

The Global Seed Vault in the Svalbard Mountains of Norway (2008), designed by Peter W. Soderman of Barlindhaug Consult, is a highly secure facility containing up to 4.5 million seeds from around the world, partially carved into a mountain for protection from variable temperatures, earthquakes, climate change, and other potentially devastating environmental impacts. Its entrance is designed in both shape and material to avoid the risks of

avalanches and major storms. The roof and front of this concrete and steel entry is a beacon signaling the presence of the structure while suggesting its function as a potential source of life rediscovered. This sculpture, entitled *Perpetual Repercussion* by its artist, Dyeke Sanne, consists of prisms, mirrors, and steel shards that combine with turquoise fiber optics to alternately reflect the subtle arctic light and to glow with its own luminosity.

Architecture can be considered an instrument that, either through passive or dynamic means, actively engages or takes advantage of environmental elements.



# environment

**Architecture exists as just one part of a total environment, engaged in an intricate balance between exploitation and enhancement.**

A building exists in, and interacts with, the environment at various scales—from the cellular to the infrastructural—and the definition of that environment is important in framing its relationship and engagement with a design. Every design should anticipate not only its impact on the environment but also the changes in

Rahul Mehrotra Associates' 2004 Rural Campus for the Tata Institute of Social Sciences (TISS) located in Tuljapur, India, builds on an ancient ventilation practice by introducing wind towers in all its buildings. These wind towers catch the wind that exists at higher elevations and draws it into the building, facilitating the integration of passive cooling to its interior spaces.



The Icelandic turf house emerged as a response to the northern climate's harsh temperatures. A roof covered with thick turf and walls made from double rows of earthen 'bricks' cut directly from the surrounding landscape form an insulating cover around the timber structure. Grenjadarstadir, Iceland, nineteenth century.

the environment that will subsequently impact it. Variable conditions that include seasonal change, temperature, precipitation, wind, solar exposure, as well as potentials for extreme weather that can be responsible for fires, flooding, avalanches, and so on, can be powerful conditions that inform architectural form.

Architecture can be considered an instrument that, both through passive or dynamic means, actively engages and takes advantage of environmental elements. Defining the terms of the environmental boundaries within which a building exists is critical to establishing the nature of its interaction. And the awareness that a building impacts not just its immediate environment, but that it exists within an expanded environmental cycle can influence such aspects as choice of materials and its subsequent ability to be an active participant in improving the environment.

#### **Instrumentation**

As with any kind of instrument, architecture too can be an opportunistic device that exploits, passively, and/or actively, environmental conditions and contexts to benefit the comfort and rituals of its inhabitants.

#### *Static, Passive*

Form, orientation, siting, and material choices can use or even amplify existing

environmental conditions to a building's benefit. Taking advantage of the natural insulation and thermal properties of earth, for example, can suggest embedding houses within the ground or making walls out of adobe bricks or rammed earth.

A building's orientation can take advantage of prevailing winds by allowing cooling breezes to move through apertures specifically designed to capture and facilitate airflow. It can harness sunlight to warm its interiors through the addition of a plane of glass layered proud of its exterior walls, making what is called a Trombe wall. Daytime heat, captured between these two surfaces is subsequently absorbed through the walls to its interior at night. The Trombe wall effect greatly minimizes temperature variations and reduces the need for supplementary heating systems.

#### *Responsive*

Architecture can be performative at multiple scales as it engages the environment. Whether it is a material that is embedded with an environmental intelligence (a form of genetic engineering, where materials are altered to serve architecture), an individual manipulating a vent, or a mechanism that rotates an entire house, a dynamic architecture is one that actively interacts with a continuously changing environment.

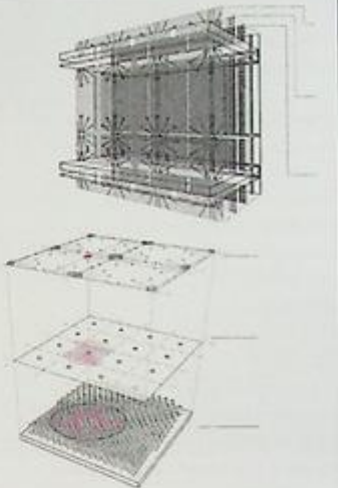
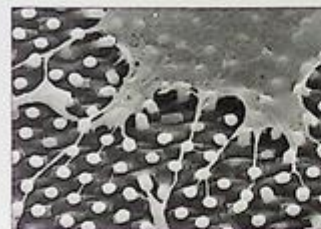

The bamboo folding screens that enclose FOA's (Foreign Office Architects) 2007 Carabanchel housing project in the periphery of Madrid allow the occupants to

control the amount of harsh sunlight filtered into their individual units, working together to create a continuously transforming façade.

Jenny Sabin and her collaborators, spanning across the fields of cell biology, materials science, electrical and systems engineering, and architecture, search to understand how context or environment can specify form, function, and structure. Dynamic biological processes offer unique insights into generative and ecological design and inform

their speculative e-Skin project—a responsive wall assembly of biomimetic surfaces composed of sensors, signals, and responses. (Cell-matrix Interface by Iñida-Stansbury and Yang, responsive wall assembly by Sabin, Lucia, and Nicol)

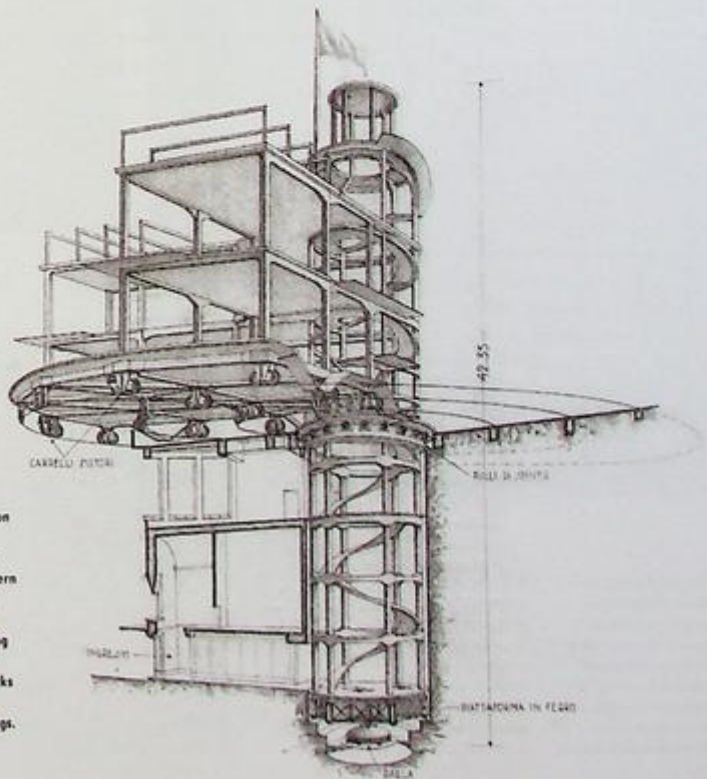

Controlled by a three-button panel, Angelo Iervolazi's 1929-34 Casa Girasole (or Sunflower House) in northern Italy rotates so that it can follow the position of the Sun. Borrowing its revolving technology from railroad turntables, the wheel's tracks are subsequently traced within the garden's plantings.



Epi-phyte Lab's Green Negligee proposes an environmental armature for an existing housing block in Bratislava, Slovakia. The performative veil, part building part landscape, finds its form through

environmental analysis. The screen hosts a range of bio-diverse systems, species, and energy-capturing devices that together address the inefficiencies of the existing building and create new spaces for social interaction.

Building envelopes for example, can be engineered to breathe or sweat to repel moisture or to become more opaque as they acoustically mediate inside and out. A responsive architecture is one that undergoes transformation as motivated by its engagement with environmental stimuli. It is one that is often embedded with scales of programmatic responses from the cellular to the mechanical.

Composite materials can be engineered to combine behaviors and characteristics that were previously identified with individual materials. The study of nature's models increasingly serves as inspiration for the development of material systems that mimic nature's ability to adapt to a continuously changing environment, where performance is often directly related to form.

Siobhan Rockcastle's 2008 Bachelor of Architecture thesis at Cornell University proposes a series of artificial groundscapes that draws contaminated water up from the water table and filters it through a canopy of live material before reintroducing

it back into the water. A component system of triangulated forms of various dimensions and densities constructs a system of elevated walkways, bridges, and follies, allowing the pedestrian to experience the remediated landscape.

## Sustainable Environments

Architecture influences the planet in which we live, and the question one should ask is: How does this sensibility affect architectural form?

### Vegetation—local and infrastructural benefits

Earth-covered roofs can both insulate and manage runoff erosion by absorbing rainwater. Green walls planted with native vegetation can provide habitats for natural species, improve air quality, absorb rainfall, as well as provide building insulation and noise reduction.

### Materials

The effect of depleting the Earth's resources in the choice of building materials can be minimized if they themselves are replaceable. It is well known, for instance, that bamboo forests are replenished every five to seven years.

### Remediation

Buildings and landscapes can contribute to the cleaning of polluted environments. Contaminated soil and water often found in abandoned industrial wastelands can be remediated through introducing frameworks that support plant growths that absorb existing pollutants or earthworks that isolate and contain contaminated earth.

### Energy

Solar panels and geothermal systems are just two examples of how the environment can be used to provide the necessary energy to enhance a structure's heating, cooling, ventilation, and power needs.

### One Man's Trash Is another Man's Treasure

An opportunistic architecture is one that reuses material that has either been discarded or considered spent. Tires, discarded soda cans, material salvaged from building demolition, and so on, can be appropriated for new constructions. Manufacturing processes that reuse already used products to produce recycled building materials reduce postconsumer waste. Material fabrication processes that use biodegradable materials can also insert themselves into this cyclical concept of regeneration.

### Holistic View

Architecture exists as part of a total environment. Environmental economies can begin to emerge as a result of considering the potentially dynamic reciprocity between multiple species and the environments that sustain them. As with the cell, where half of what defines its behavior is what exists outside of it, complimentary systems feed each other and build on symbiotic and cyclical relationships to construct sustainable and fluid environmental ecologies.





MINIWIZ uses recycled PET bottles to form its POLLI-Bricks, an architectural brick capable of cladding entire buildings. The 2010 EcoARK constructed as the main exhibition hall of the Taipei International Flora Exposition uses these recycled bottles as its primary building material. The translucent blocks can be disassembled and reused elsewhere.



Caroline O'Donnell of CDDA's "Party Wall" uses detritus from a skateboard manufacturer as its primary cladding for MOMA's PS1 2013 summer pavilion. The scalelike wooden shards create a porous skin that not only offers summer shade but can also be detached to provide event seating.

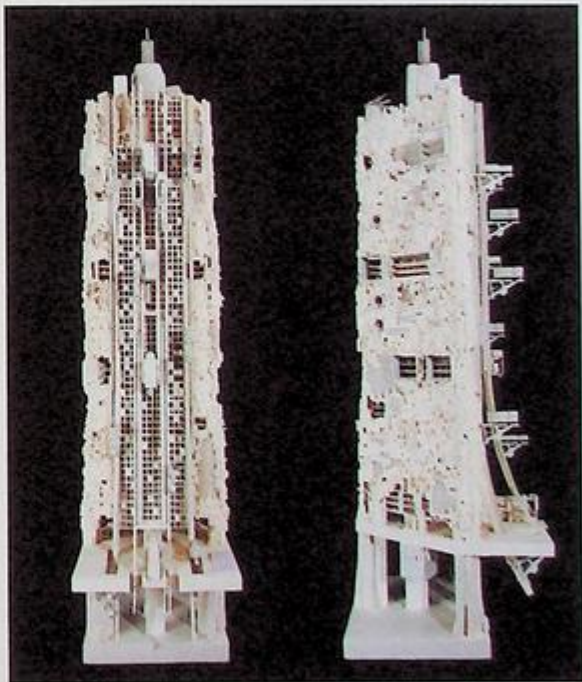

Terreform ONE's Rapid Re(f) use: Waste to Resource City 2120 project proposes a landscape in continuous motion, where nothing is ever really thrown away. Here, trash is separated into material categories and, instead of being arbitrarily

compacted, is transformed into various shapes that can be subsequently assembled for new construction. The city is continuously rebuilding itself from what has been discarded.

In architecture, a sense of mass is derived from the noticeable presence of volumetric density.



# mass

**Paradoxically, a sense of massiveness can be most evident in conditions of apparent weightlessness.**

Most consider the making of buildings to be an additive process—and indeed it usually is. It is the layering of multiple materials and systems that, together, construct the completed edifice. However, when a work is conceptually conceived as a monolithic volume, the resulting mass transcends the thinness of these layers.



The walls of Wang Shu and Lu Wenyu's 2008 Ningbo Historic Museum in Ningbo China are constructed of bricks and tiles recycled from local buildings. A delicate imbalance is achieved between the massive form with its tilting surfaces and

the seeming fragility of each material component. It stands as a monumental testament of the absence of those structures devastated by disaster and of the presence of (vanishing) construction traditions.

And though buildings tend to be thought of as massive if they are very large, a sense of mass in and of itself does not necessarily suggest scale. Mass is the distinct presence of volumetric density.

The pyramids of Egypt are masses that convey solidity and impenetrability. Embedded within their cores are the inner sanctums of the pharaohs for whom they were built. Here, mass is both a literal volume of stacked blocks of stone and a symbolic one of impenetrability and longevity. The secret passage through which the mummy was transported is conceptually understood as an excavation within this mass—a negative space that is conceived through the removal of mass.

### Processes

A sense of mass is achieved by the relentless repetition or aggregation of material or volume that subsequently transcend their individual incrementalism in favor of a monolithic surface or volume. Yet, conceptually, mass is conceived as a solid form, from which spaces have been subsequently "carved."

#### Additive

A sense of mass is exaggerated by the repetition and accumulation of elements that are known to possess considerable mass—as in a pile of stones or bricks or a stacking of logs.

(continued on page 69)



In Peter Zumthor's Thermal Baths in Vals, Switzerland, mass is achieved at two distinct scales. A series of (often occupiable) piers in spatial dialogue with one another together construct mass at the building scale.

The spaces that are defined between these piers are read as the primary spatial voids. At another scale, bands of compressed gneiss produce a monolithic mass of material density.



Alberto Burri's Cretto—a land art installation in Gibellina, Sicily—is conceived as a memorial to the victims of the 1968 earthquake that destroyed the town. Here, the wreckage was amassed back into the blocks by which the town had originally been organized and a blanket of

concrete poured atop the rubble. The abstracted urban monolith references the town's physical past and embedded within the masses that construct the ghosted streets is the physical detritus of imagined narratives.



# Mendes da Rocha and the Levitation of Mass

The Brazilian architect Paulo Mendes da Rocha asks a group of students if they know why the pyramids were built. After all of the traditional answers have been hesitantly proffered and rejected, with Mendes da Rocha all the while shaking his head, he goes on to say, "The pyramids were built because someone pointed at a giant rock lying on the ground and asked, 'How can we get *this up there?*'" and then he points up into the sky.

The exhibition of getting *this up there* is a recurrent theme in his work, which inevitably involves masses that are not simply floating but, at times, appear to be caught between ascent and descent, hovering over plazas, pools, and even other buildings.

Because concrete, his material of choice, is intrinsically very heavy, to see it float is to witness an almost supernatural event, with viewers' responses being more of a subjective, emotional order than an objective, rational one. Still, the levitation of mass demands a resolution in physics, and Mendes da Rocha supplies these resolutions ... sparingly.

One encounters the importance of mass at the Brazilian Museum of Sculpture in São Paulo. If the neoclassic museum required a grand portico to signify its entrance as well as its importance, Mendes da Rocha uses a giant beam spanning the site to mark the presence of this important museum. This hollow beam, delicately supported on its two end walls with seven steel joints, houses lighting and storage for outdoor events, while protecting from sun and weather the plaza that is in turn the actual roof of the museum as well as its principal exterior public space. Investigating this hulking yet buoyant block, one discovers the primary interior spaces of the museum

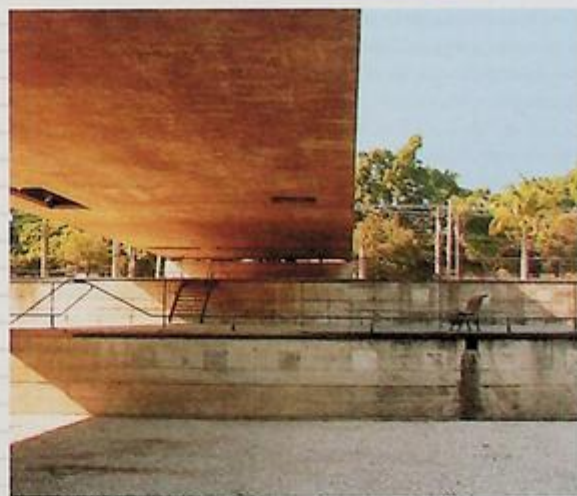

Mendes da Rocha: Brazilian Museum of Sculpture.  
São Paulo, Brazil, 1968



Mendes da Rocha: Underground passage entry on the Patriarch Plaza, São Paulo, Brazil, 1992



Mendes da Rocha & METRO Arquitetos: Cais das Artes, Vitória, ES, Brazil, 2008

below, carved into the gently sloped site on a corner of a residential neighborhood. The block provides the museum with its symbolic portico, yet preserves the scale of the neighborhood by reducing the bulk of the museum itself.

Similarly, the huge steel blade that soars above the entrance to the underground passage in Patriarch Plaza in São Paulo protects the escalators and stairs from the elements while sketching an elegant arched entryway over what might otherwise have been just a hole in the ground. The huge square arch that marks entry into this important space seems almost to twist and crack as it sends two brackets downward to support the asymmetrical, curved arch over the stairs. This arch then frames views from within and through the space, ironically providing a human scale from beneath while presenting a monumental scale when viewed from the city, a monumentality that suggests the importance of the gallery buried below, giving access to one of the city's primary urban parks.

The main gallery block of the Cais das Artes (Arts Quay) in Vitória, designed with METRO Arquitetos, seems to leap and frolic above the pavement of the quay, permitting views of the bay beyond and contrasting with the resolute groundedness of the auditorium cube. Supported only on three pairs of columns, the massive hollowed concrete side walls (gigantic trussed beams, actually) support the interior floors, their varying heights indicated by the steps of the walls. Light reflected from the plaza below lights the galleries through the gaps between the staggered floor slabs. One moves about within the museum with the same grace the museum moves about the quay. Once more, Mendes da Rocha derives lyricism from massiveness.

*Concrete becomes cloudlike.*

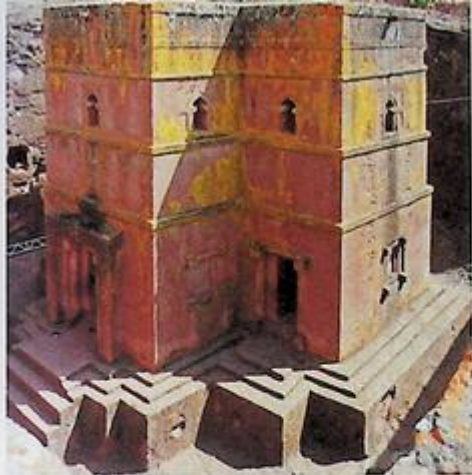

In Ethiopia, Bete Giyorgis (or the Church of St. George, twelfth century) has been carved from the solid volcanic rock in which it is located. Here, the construction of mass

and space results from a subtractive process, a literal excavation that simultaneously produces the mass (solid) of the church and its occupable spaces (voids).



Conceptually understood as an initially solid volume from which discrete masses have been removed, the resulting voids in I. M. Pei's 1973 Johnson Museum in Ithaca, New York, are spatial inscriptions and extensions

of the regulating lines and data of the surrounding context: extensions of existing campus paths, views that align the building with the distant landscape, and parapet heights of adjacent buildings.

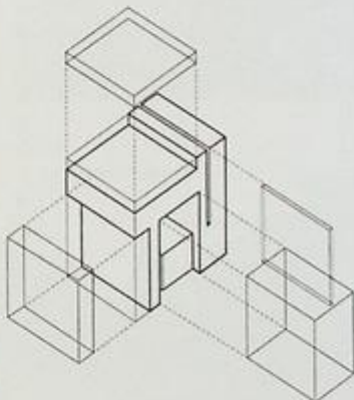

### Subtractive

By cutting into a solid, its thickness is revealed; massiveness is disclosed by the removal of substance that allows one to perceive its dimensions.

Architectural *poché*, on the other hand, is the occupiable space that appears to be excavated *within* the mass. Typically, it is hierarchically secondary in programmatic significance yet introduces another spatial layer within the "ground" of the mass whose surfaces define the primary spaces of the building. This ground can often become a figural accomplice to the shaping of architectural space.

The Nolli Plan of Rome, for example (see chapter 11), represents the city as a solid mass within which a series of figural voids has been conceptually excavated. There, the city is conceived as the inhabitable *poché* of everyday life whose building surfaces produce the background for the figural voids of civic and religious spaces. Here, the public interior spaces of the city are given for the first time equivalent status as public exterior spaces, producing a seamless spatial condition of quotidian market, palazzo courtyard, religious sanctuary, and ceremonial piazza, all defined by the backdrop of the inhabitable mass of the city.

The showers, toilets, and cupboards of Pierre Chareau's 1928 *Maison de Verre* in Paris, France, occupy the *poché* that sculpts the spaces of the principal bedrooms and bathrooms.

Their volumes reveal their programmatic contours and dimensions while establishing the spatial perimeters of the spaces that their surfaces define.

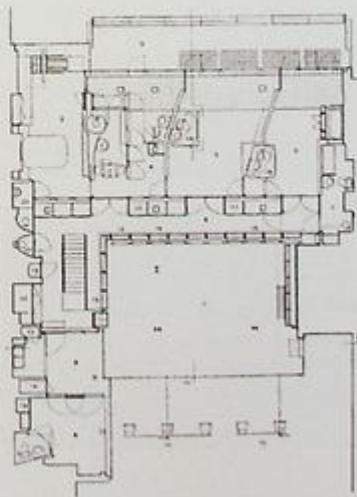

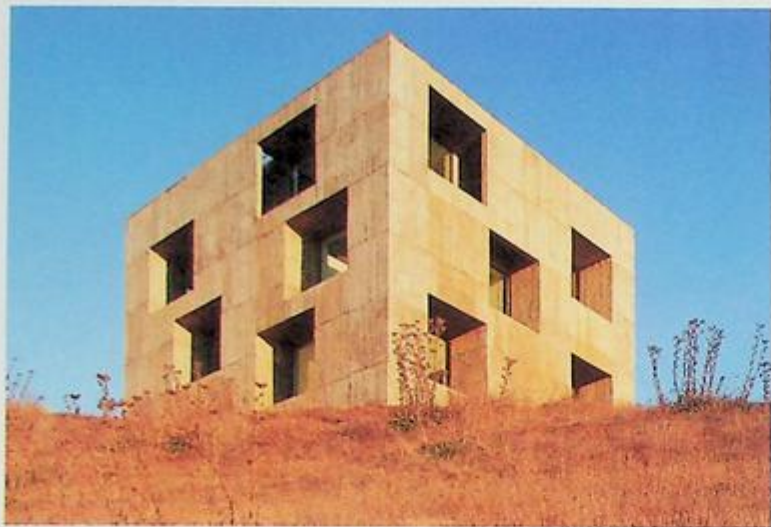

In Pezo and Von Ellrichshausen's 2005 Casa Polli in the Collumo peninsula of southern Chile, the cubic mass of rough concrete emerges from its site as a lighthouse might on the rocky precipice of the

Pacific Ocean. The perimeter walls that also define its primary spaces not only serve to locate its services and circulation, but they become the primary screen through which the landscape and gaze is framed and mediated.

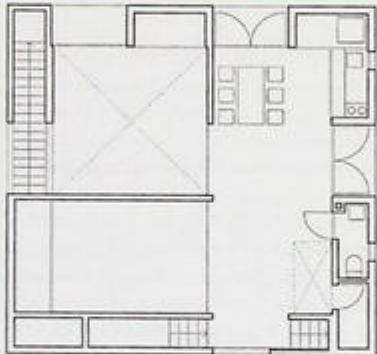

Grafton Architects' sectional study model for their 2008 Bocconi University in Milan, Italy, demonstrates a spatial density where both the primary auditoria and "streets" between buildings

are conceptually carved from a geological mass, producing an occupiable landscape that mediates between the scale of the building and the scale of the city in which it is embedded.

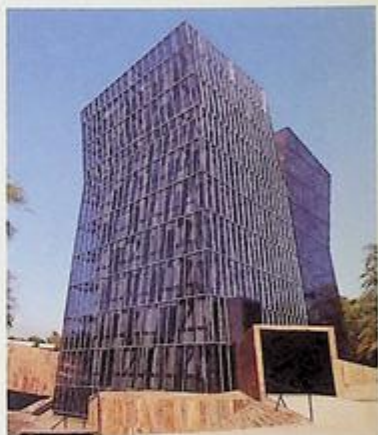

The "Siamese Towers" of the Technology Center at Catholic University in Santiago, Chile, are clad in a series of skins, an outer one of clear glass and an inner one of fiber cement. The collectively opaque, yet constantly transforming

surface, privileges the reading of a solid mass—one where scale and detail give way to profile and silhouette, a monolith set against the distant snow covered mountains. Alejandro Aravena, 2005-05

### Characteristics

Density and gravity are terms that are most commonly associated with mass—the impenetrability of a volume or its perceptual weight.

#### Density

A sense of mass can be achieved through material or spatial density, as in a stone wall or a medieval village, where the heaviness of the material and the relationship of solid to void contribute to the perception of density. Monolithic form can also convey a sense of

mass—however here density is not equated with weight or lack of space, but rather with opacity and lack of scale.

#### Gravity

While all buildings are in a perpetual state of resisting gravitational forces, an awareness of this resistance can be amplified through detaching or articulating a structure from its ground. It is in this condition of apparent weightlessness that a sense of massiveness can be most evident.



The two shells of Massimiliano Fuksas's San Paolo Apostolo in Foligno, Italy (2001-09), are simultaneously heavy and light. The exterior concrete shell is a seemingly impenetrable box that

detaches its industrial context from its interior sacred space. The idealized interior is suspended within this exterior shell by strands of concrete shafts that, in turn, draw exterior light to its interior.

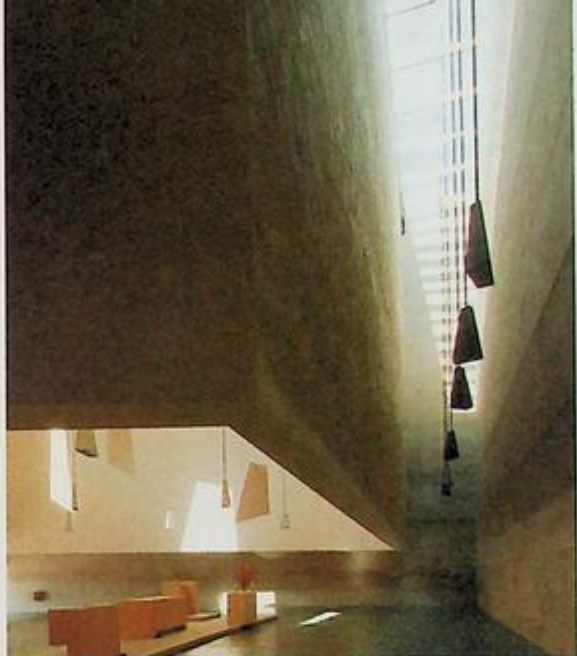

Mario Fiorentino and Giuseppe Perugini's Fosse Ardeatine, the 1945-52 cemetery and monument outside Rome, marks the mass execution of Italian civilians by the German occupation on March 24.

1944. Here, the solemnity of the event is given presence through the mass of the enormous concrete sarcophagus that hovers above the graves and beneath which the visitors pass.



Lina Bo Bardi's 1968 São Paulo Museum of Art lifts the volume of the museum's primary galleries and suspends it from two enormous beams supported on four pillars. The resulting space captured between the lower ground plane (in which

are embedded the museum's auditoria and supporting spaces) and the hovering mass above creates the Belvedere—an urban piazza that connects the Paulista Avenue to the city of São Paulo and the distant mountains beyond.

Structure can be understood to be that aspect of every construction that assists in countering gravity and transferring loads into the ground.



# structure

**The interplay between elements in tension and those in compression has been a fundamental aspect in the development of architectural forms.**

A common metaphor, whereby architecture is represented as a body, considers structure to be a form of skeletal system. This is only sometimes true, however, in the cases when the various building systems—skin, mechanical, interior finishes, and so on—are separated. It is perhaps most profitable to



The Hemeroscopium, a house outside Madrid, Spain, completed in 2005 by Antón García-Abril and Ensemble Studio, is a composition of expressed equilibrium, comprised of six different

beams piled in a spiral that culminates in a twenty-ton counterweight that is located at the "G(ravity) Point." Two beams of water-swimming pools—offer compositional balance to the construction.

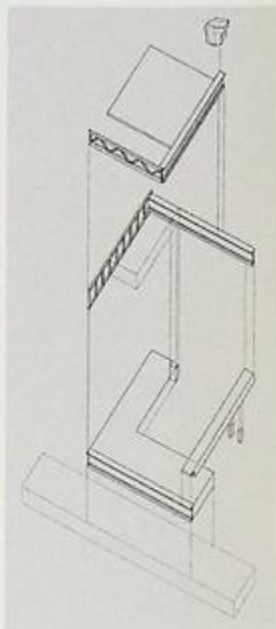

consider structure to be that aspect of every construction that assists in *countering gravity* and *transferring loads* into the ground. While gravity is a constant for most earth-bound architecture, loads can vary widely—even during the life of a building—depending on the materials used, the occupation of the building, and even the effects of wind and precipitation.

The beautiful efficiency of the earliest human shelters probably developed from the occupation of natural structures: caves and trees. Once humans found themselves searching for food in situations where there might have been no available shelter,

branches, leaves, and bark were most likely used to simulate the protection of trees. It is commonly believed that with these branches and the trunks against which lean-tos were supported, columns may have had their origin. Perhaps memories of the spatial characteristics of caves encouraged the development of vaults and domed spaces.

Regardless, most early structures were composed primarily of elements that were in *compression*; that is, the tree trunks, bricks, and stones—then columns, walls, and arches—were typically being squeezed by gravity.

(continued on page 77)



The billowing and apparently weightless roof structure of the 1972 Munich Olympic Stadium by Frei Otto and Gunther Behnisch is only one part of a comprehensive architecture that connected a number of the Olympic sites beneath a continuous mesh

of steel tensile structures covered with PVC-coated polyester and supported by steel masts and concrete anchors. As with traditional tent structures, the Olympic buildings were fully constructed off site, and then erected in just a few days.

# Shigeru Ban and the Softness of Structure

Shigeru Ban delights in making strong structures out of weak material. Through multiplication and increases in dimension, previously unimagined structural properties are introduced to standard materials. The result is a structural expression that is characterized by the distinct qualities of the weak material, one that is simultaneously familiar and yet abstract. The building's spatial program is the structure and whether it is through recycled paper, cardboard tubes, wood laminates, or shipping containers, the structures are designed according to the strength of the material used, taking advantage of the characteristic of the material itself. The material operates as a found object, imparting its inherent limitations to its creative redeployment.

Shigeru Ban has said that he discards material preconceptions and in so doing is able to connect the material or shape of a standard material with an abstract idea, one that is often informed by an environmental sensibility. As with his 2009 installation for the London Design Festival, his paper-tube structures have introduced a poetic value to a relatively low-tech and adaptable material. Here, the triangulated filigree of compressed cardboard tubes rose 72 feet (22 m) above the south bank of the Thames, a skeletal structure that simultaneously evoked the area's industrial past while referencing the underlying timber-framed structure of the nearby reconstruction of the Globe Theater and the timber navigational pylons of the Thames. A material normally used to make boxes was redeployed to produce a geometric spider web that not only pushed the boundaries of the material's potential, but situated it within a complex set of cultural and historical contexts.



Shigeru Ban: London Design Festival, London, England, 2009, tower and detail

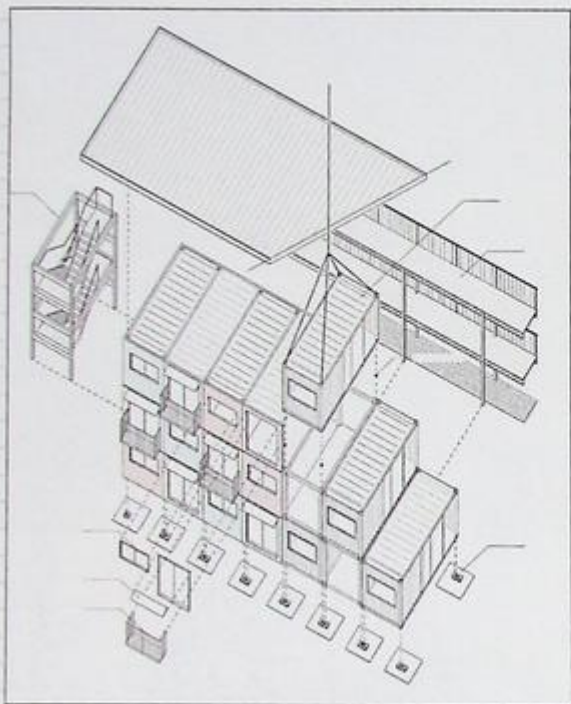

Shigeru Ban: Temporary Housing Shelter, Onagawa, Japan, 2011, axonometric



Top: Shigeru Ban: Paper Bridge, Gardon River, France, 2007  
Above: Shigeru Ban: Haesley Nine Bridges Golf Club House, Yeosu, South Korea, 2009

In Onagawa, Japan, following the earthquake of 2011, Shigeru Ban deploys a checkerboard of 20-foot (6 m) shipping containers to construct a temporary housing shelter. Here, the prosaic shipping container is reused as the basic building block of a three-story structure. The structural expression of the construction emerges as a result of the multiplication and stacking of the standard container, a found object—the alternating arrangement producing the simultaneous spatial requirements for both storage and open living spaces.

challenges our material and structural preconceptions. In the shadow of the massively constructed stone bridge of Pont du Gard, a proliferation of lightweight cardboard tubes construct two arched trusses that support a suspended walkway of recycled paper and plastic, a ghosted reference to the Roman engineering that preceded it. Not unlike the stone that produced the Roman bridge, the spanning structure is a demonstration of the discovered properties of the cardboard tubes that function as its primary building block.

"Structure itself is decoration," Shigeru Ban explains in a 2007 *Design Boom* interview—and nowhere else is this more evident than in the 2009 Haesley Nine Bridges Golf

Club House in Yeosu, South Korea. The bundling of individual timber elements gives way to a hexagonal latticework—fusing columns with surface into an uninterrupted structural expression. The aggregation of an otherwise inconsequential material amplifies its structural and spatial potential—the material itself seems to have been enlarged under a microscope as we experience the beauty of its magnified world.

Imagine a bridge that would span a river, and that bridge would be made of paper. In the south of France, Shigeru Ban again

Perhaps it was the bending of saplings against stronger trees, and the stretching of ropes, and later chains, upon which bark or slivers of stone were added, that led to the usage of structures in tension. When a material is in tension, it becomes stretched by gravity, even if such stretching is not noticeable to the naked eye.

The interplay between elements in tension and those in compression has been a fundamental aspect in the development of architectural forms.

### Elements

The basic elements of a structural system are also the primary elements in the production of architectural space: columns, walls, beams, slabs, and their various combinations.

### Walls

It is not surprising that most of the earliest architecture to survive until our time was a mural architecture, that is, buildings composed of walls. Walls could be easily constructed by stacking earth, wood, or masonry. Thick walls, whether straight sided or battered (with sloping sides), are among the most efficient methods for transferring loads from a roof into the ground. They are also very effective in the separation of spaces, especially in dividing the public from the private elements of a building or city (not to mention fortified walls, separating a city from an attacking enemy).

Retaining walls are used to hold back earth or sand and to prevent erosion and other forms of soil migration. It is often necessary to construct retaining walls in order to stabilize the ground when constructing on a slope. Retaining walls essentially reconfigure hillsides, transforming a natural topography into an architectural feature.

### Columns

In addition to collecting roof loads from arches or beams and then transferring them vertically into the ground, columns provide a way for space (and people) to move through the various layers of a building. In their earliest manifestations, columns were understood as pieces of a discontinuous wall.

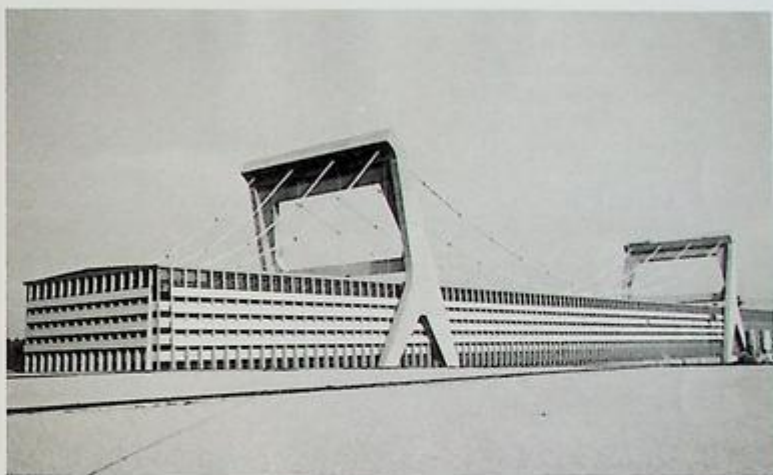

For the Burgo Paper Factory in Mantua, Italy (completed in 1965), a column-free area of almost 90,000 square feet (8,100 sq m) was needed to accommodate the paper manufacturing equipment

and its linear processing of wood pulp into rolls of newsprint. The architect-engineer Pier Luigi Nervi designed a graceful suspension bridge-like structure, 815 feet (248 m) long and

98 feet (30 m) wide, supported by two pylons that clearly communicate the transfer of loads from cables into the ground.



In the Johnson Wax Headquarters building in Racine, Wisconsin (1936–39), by Frank Lloyd Wright, columns gradually spread

toward their tops to become elements of a roof network, with ample skylights spanning between the hovering, disklike slabs.

The effect is of a carefully modulated grid of delicate columns with a flood of natural light penetrating between their canopies.

squarish in plan and massive in dimension. Eventually, columns began to become more objectlike, and arches—especially when connected in a series—could span fairly large distances, with their loads carried downward by increasingly slender columns.

Perhaps originating as replications of trees or, among the more nomadic groups, of tent poles, columns have always been considered to be among the most expressive elements of architectural construction. Since the ancient Egyptians modeled columns on the culturally significant papyrus plants, palm trees, and lotus flowers, with faceted sides possibly implying tree bark, columns have been among the most sculptural components of a building. Columns have been shaped to reflect theories of architecture's origins, of classical perfection, or harmonic order.

While a wall can be composed of a variety of pieces, even of mud and piled stones, singularly or in combination, columns require more carefully constructed elements: the failure of a column tends to be more perilous than the failure of a piece of wall. It is not surprising, then, that in order to symbolically fortify the apparent strength of a column, one even finds columns that personify the carrying of weight: female caryatid figures appear on the Acropolis, with the male versions—atlantes and telamones—becoming very popular from the sixteenth century onward.

It is a testament to the architectural importance of columns that, as architecture evolved, columns were even applied to walls as a form of decoration—pilasters and half columns—as if to bring to the surface the latent strength and order that columns can impart to a wall.

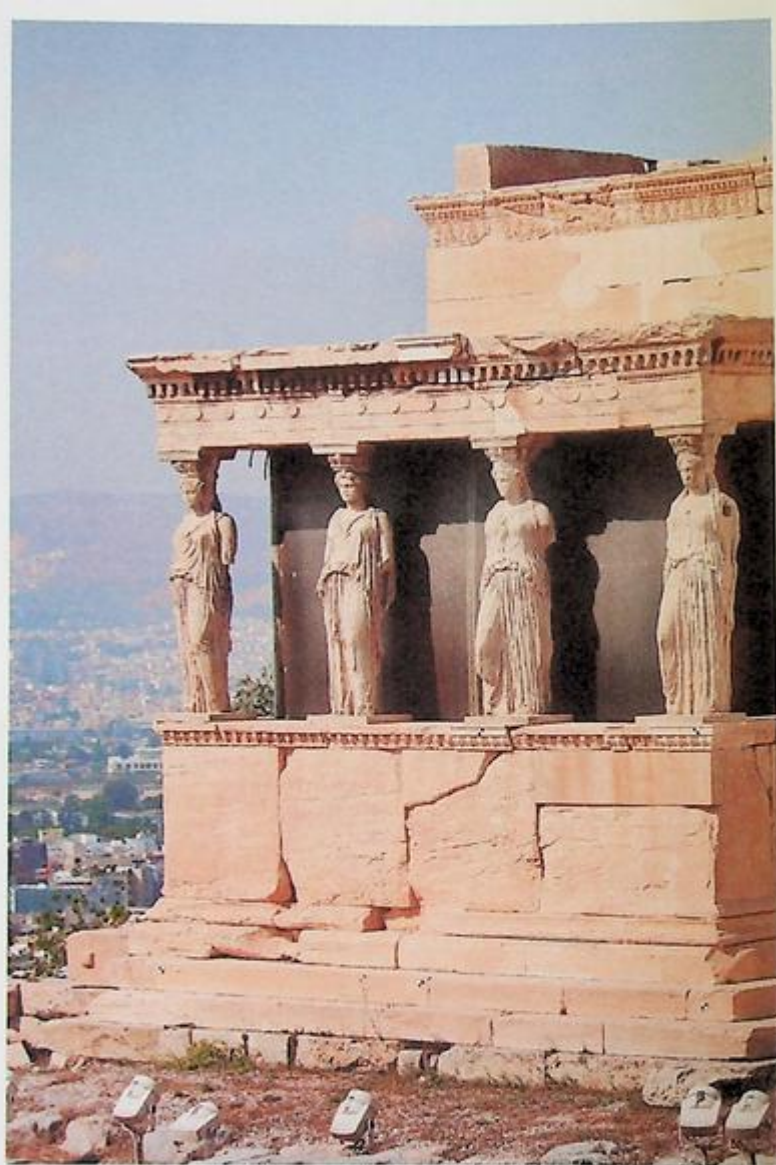

The Porch of the Caryatids at the Erechtheion in Athens (c. 420–405 BCE), probably sculpted by Phidias, demonstrates columns in their most decorative and

metaphorical condition, with the massive weight of the roof transferred through the necks of the individually carved maidens.



### Beams

Beams are a building's principal element of horizontal structure. Beams typically accept loads along their entire length to be transferred downward to be collected into two or more points, on either walls or columns. Most structures have a hierarchy of beams, with primary beams being the principal contact with the vertical structure and secondary beams (or joists) spanning between these primary beams. In the case of especially large structures, there may even be tertiary beams.

While walls and columns are generally being *compressed*, beams are most frequently in a state of *bending*. For this reason, beams are usually composed of materials that can withstand a degree of flex. Occasionally, a beam will be comprised of laminated layers, often of glued wood, in order to more effectively resist bending.

Trusses are composed of triangulated elements, usually of metal or wood, that can span great distances with less mass and greater efficiency than most beams. Because trusses are largely open, they offer greater possibilities for containing service elements and, if large enough, even entire floors.

Structural arches—more common today in bridge construction than in architecture—might be considered to be bent beams. They are wholly in compression, transferring their forces downward in an arc onto a column or wall. The addition of hinges at the two points of contact and, on occasion, also at the apex of its arc, allows an arch to flex under a variety of loads and changes in temperature.

### Slabs

As Sandaker, Eggen, and Cruvellier point out in *The Structural Basis of Architecture*, “The slab is perhaps the most ubiquitous and yet under-appreciated of all structural elements.” Providing the predominant horizontal surfaces of a building, slabs often present themselves as floors and ceilings. The structural aspect of slabs (they could be considered to be expansive, flat beams) is often overlooked. Not only do slabs span between columns, they can also provide stability to the perimeter walls, support intermediate non-load-bearing partitions, and carry the massive “live” loads—essentially people, vehicles, furnishings, and occasionally wind, rain, and snow—that a building needs to accommodate.

The Rolex Learning Center in Lausanne by SANAA (completed in 2010) is composed of an undulating base slab, much like a series of domes that forms a rolling interior terrain of mounds, archways, and courtyards. The equally undulating roof

is composed of individually shaped laser-cut curved wood beams supporting a series of thinner roof membranes. The effect is that of being in an expansive interior landscape with very few columns, from which one can view the distant Alpine landscape.

Slabs do not necessarily need to be flat or even straight. While the tops of slabs usually provide the basic surface of floors, the undersides of slabs can be ridged, providing directionality, or with deep wafflelike indentations, thereby performing in a multidirectional mode. When exposed, the undersides of such slabs can provide a visual complexity that can bring scale and texture to a space.

#### Hybrids

A vault might be considered to be like either a bent slab or an extruded arch. Vaults can span large distances, transferring their loads both downward and outward along their two sides. Because of the massive loads that can be deposited along these sides, vaults are usually constructed either with thickened walls lining their edges, additional counter-vaults converging on the sides, or some form of buttress that can assist in transferring the loads diagonally downward into the ground.

Domes might be considered to be like arches that are spun along their central axis. In fact, beginning with gothic architecture, many domes consist of a series of arched ribs that converges in a center. As with vaults, domes require a considerable amount of support along their edges in order to transfer the radial forces diagonally downward. As materials evolved, it became common to see tensile elements—chains, iron rods, and cables—employed in vaults, domes, and similar structures to bind the opposing sides together in order to resist outward thrusts, holding the structure together from within.

Space frames are essentially three-dimensional trusses: vast expanses of lightweight elements—usually steel or aluminum—interlaced in a large, triangulated mat, like a giant tabletop requiring few points of vertical support. Because of their internal geometries, space frames can be modified to take on virtually any profile, even highly irregular configurations.

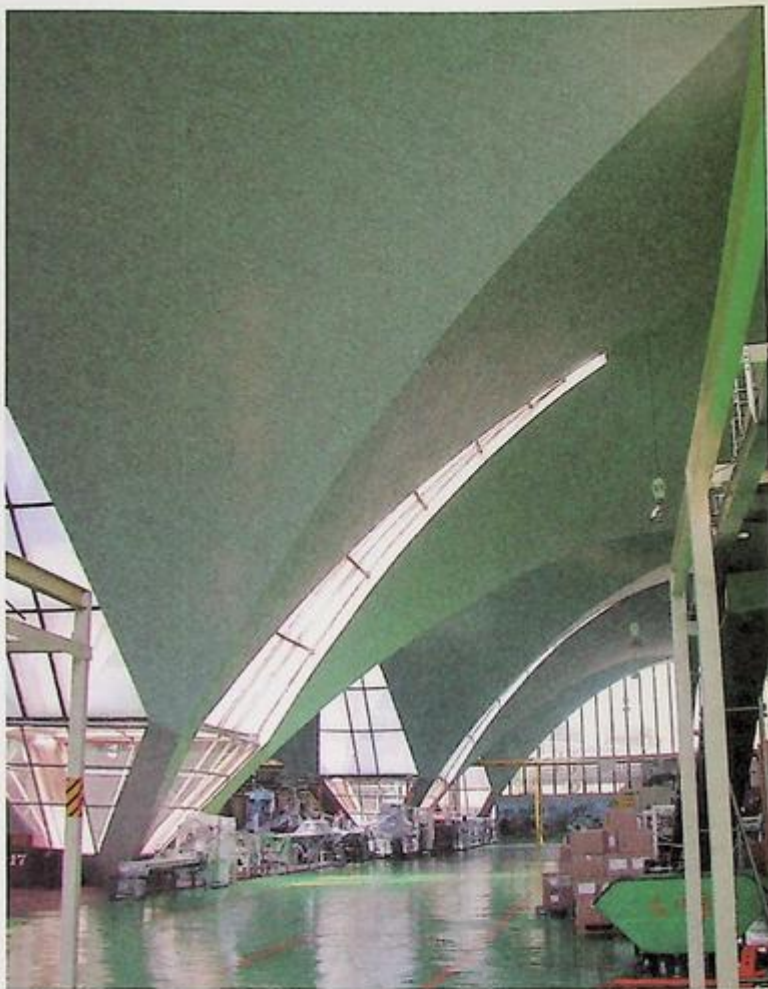

Felix Candela's Bacardi Rum bottling plant in Cuautitlan, Mexico (1959), is one of the most elegant examples of a reinforced concrete shell structures. Composed of a series of groin vaults (two vaults intersecting at

90 degrees) that are little more than an inch thick at their peaks, the structure presents large, high-ceilinged interior space while providing ample light for the industrial operations yet limiting direct sunlight.



The works of Spanish architect Santiago Calatrava consistently propose an elaborate balance between elements in tension and those in compression, rendered completely in white so that the structural figures coalesce to form a singular

composition. The results often resemble the delicate skeletal structure of birds, though at an enormous scale, as here at the Quadracci Pavilion of the Milwaukee Art Museum (completed in 2001) with its combination of sun-screening with enclosed spaces.

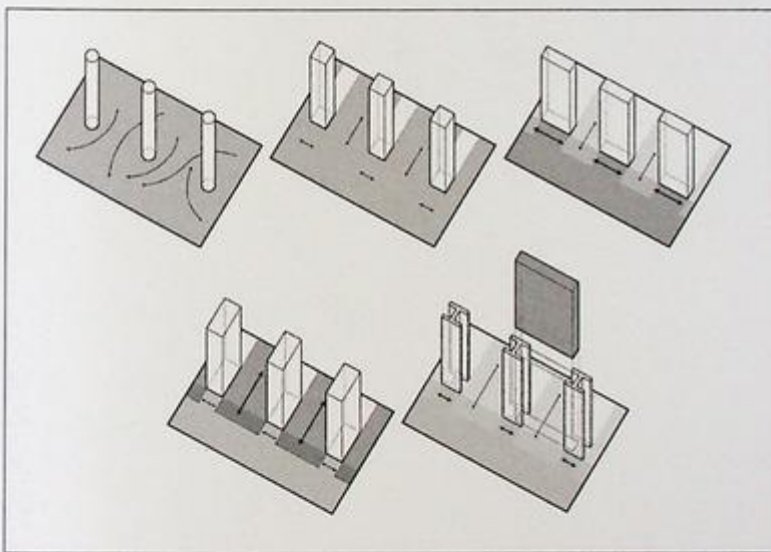

Columns, their shapes, and spacing, can determine the ways in which spaces are perceived and imply the ways in which one might move from one area to another. Round columns, for instance, tend to be multidirectional,

with movement flowing freely around them. At the opposite extreme, a row of piers can appear opaque when viewed on the oblique but emphasize movement parallel to their long surfaces.

## Structural Space

In the earliest times, a construction was its structure. The exterior forms and interior spaces of prehistoric and ancient architectures were inevitably a direct manifestation of their structure. As time passed, the desire to embellish this structure with additional elements, to infill gaps with windows or decorative features, to attach finials and gargoyles and false façades, led to a certain cloaking of structure. Issues such as acoustics and temperature control eventually led to the separation of a building's interior elements and its structure (one thinks of wood paneled libraries and the vast reverberation chambers above theaters). Exteriors even displayed layers of implied structure—*aedicules*, niches, pilasters, half columns, and latticelike grids—that masked the actual structure within.

As more materials and processes of fabrication became available, the elements of a building's structure began to develop greater efficiencies and capabilities. It became easier to subsume structure within the thickness of a floor plane or the thinness of a membrane, hiding the structure from view.

But, regardless of the visual evidence of a building's structure, the enactment of its battle with gravity and its accommodation of loads continue to have a profound effect on architectural forms, on the shaping of spaces, and on our experiences of the work as a whole.



# surface

**A building's enclosure is its primary contact with an exterior. Like clothing, its role is protection, while offering an insight into the "personality" it projects.**

Just as a first impression is often drawn from the expressiveness of a face, the vertical surfaces of a building are usually the first, most communicative aspect of a structure's design. From tepees tattooed with autobiography to chalets embellished with painted window frames, from the portals of gothic

Within a thickness of just a few inches, Michele Sanmicheli's Palazzo Canossa in Verona (1527) accomplishes an abundance of apparent depth. Like a huge and complex basket, horizontal moldings weave in and out behind pilasters and in front of windows; in the rusticated base, window sills appear to be squeezed from a recessed band; the pilasters on the upper floors seem to penetrate the massive cornice line; and a central element of three large arches—duplicating the proportions of those above—lead the eye into a deep porch and further to the banks of the River Adige.



cathedrals encrusted with saints to the façades of Renaissance palazzi proffering treatises on architecture, from the mechanical efficiencies of early industrial buildings to the meticulously detailed slickness of a corporate curtain wall, surfaces—transparent or opaque—will always introduce a building's essence. A surface is a building's face to the public, its physiognomic expression, and its civic mask.

In most incarnations, the surfaces of a building display to an observing public the function of the structure—home, place of bathing, place of worship, place of fortification, place of imprisonment, place of education. However, these displays tend to become subtler at times when architecture passes through periods of reevaluating its material elements, when it becomes engaged in the polemics of other arts, or when it is determined to demonstrate a scientific argument.

### Perception

During the Renaissance, for example, architectural treatises were inevitably based on the then newly defined artistic fundamental of linear perspective. Perspective in the arts gave us an awareness of the horizon, of the vanishing point, and—perhaps most important for the evolution of surfaces—of the picture plane. The surface of a building, especially the building's most frontal surface (the one facing the ideal viewer), could be considered equivalent to the surface of a painting: it can project objects from behind, suggest objects in front, introduce various subjects one in front of the other. A building's surface can, within just a few inches of thickness, imply unfathomable depths.

The effects of light and dark, as well as of colors also lend a building's surface a sense of relative depths, or of layers of information, or even of a type of camouflage: it can blend in with its landscape, develop an affinity for its neighboring buildings, or recede into a texture of other, similar volumes.

(continued on page 87)



The eighteenth-century French architect Jean-Jacques Lequeu was convinced that human physiognomy could inform the design of buildings and that the overall facial distortions resulting from specific emotional and physical impulses could be translated into elevations that could communicate

similar information. His *Nouvelle Méthode* text employed numerous self-portraits (including *Le Grand Baillieur* [sic], or *The Large Yawn*, of 1777-1824), then transferred by the gridded techniques used by draftsmen in representing both human figures as well as engineering projects and military architecture.



As one's eyes move over and around a surface, it is possible to encounter many levels of suggested depth. In this wooden model of Michelangelo's project for the façade of San Lorenzo (made to his specifications in 1517), the two buildings that appear to be stacked on top of each other are unified by three openings topped by arches.

The central opening at the top appears to recede into an illusory depth, suggested by a false perspective. Upon focusing on this deep window, the proportional affinities to the larger door below—framed by the two original openings—become apparent, leading it to appear to emerge into an artificially close foreground.

# Barkow Leibinger and the Active Surface

The architectural surface is normally conceived of as a vertical plane that encloses—one that is primarily concerned with providing security and ventilation and demarcating the limits between public and private. Barkow Leibinger challenge these assumptions, arguing instead that the architectural surface, regardless of its orientation, is one that has a responsibility to demonstrate the ephemeral traces of a particular program and site. Their surfaces are conceived as topographical landscapes that actively register the passage of light or of gaze, the dimension of structural increment, the polychromy of context or the collection of water. In so doing, they produce the spatiality of the surface, blurring the boundaries between inside and out, between sky and ground.

In their 1998 Laser Machine and Tool Factory in Stuttgart, Germany, the roof is the primary surface that is activated. A normally static membrane is here transformed into an undulating surface of glass and aluminum clerestories that simultaneously illuminates the production halls below and collects rainwater for laser cooling. The resulting three-dimensional patchwork references both the physical context of agricultural fields and an historical context of annexed allotments.

The tower addition proposed in their Bremerhaven 2000 competition entry fuses surface with building mass. Surface here is not relegated to a more or less modest planar dimension. Instead, surface is a volumetric registration of the building's programs—a seamless expression of the spatial configuration and material differences of a wide range of programmatic variables that are literally stacked one atop the other—a full-scale Rubik's Cube, where a standardized unit gives way to a highly articulated increment.



Barkow Leibinger: Laser Machine and Tool Factory, Stuttgart, Germany, 1998  
axonometric and exterior view of roof

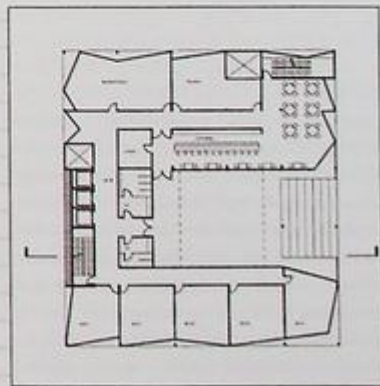

Barkow Leibinger: Bremerhaven 2000 competition entry, 2000,  
exterior rendering and upper floor plan



Barkow Leibinger: TRUTEC Building, Seoul, South Korea, 2006, exterior view

In Barkow Leibinger's TRUTEC Building in Seoul, South Korea, an entire city is registered within an 8-inch (20 cm) surface. Glass shingles clad an otherwise modest structure, and yet it is the precision of their crystalline chamfers that collapses animate readings of its physical and ephemeral context onto its surface. The surface is a pixelated skin—an architectural Chuck Close—whose reading continuously fluctuates, a function of weather, sun, angle of vision, and evolving urban contexts. Here, the surface *performs*: at times the building is camouflaged as it reflects (becomes) its surroundings, at others it is a beacon of

polychromatic light—like a 1960s Moon crystal that splits the spectrum into its corresponding colors and is simultaneously invested with its (urban) healing powers.

The load-bearing concrete grid of precast elements drapes itself across the rectangular body of Barkow Leibinger's 2012 Tour Total headquarters building in Berlin. The surface behaves as a structural *moiré*, folding and crimping as it appears alternately opaque and transparent. Here, surface operates as a constructed geometric pattern, one that is programmed by a dynamic interface between gravity, scale, and material.



Barkow Leibinger: Tour Total, Berlin, Germany, 2012, exterior view and exterior detail



Giuseppe Terragni's Casa del Fascio in Como, Italy. (1932–36; now a civic office building and renamed the Casa del Popolo) is proportionally a precise half cube. Each of its four sides has a similar geometric organization, but with

varying degrees of depth to the openings, ranging from very deep terraces (as above on the right), to subdivided windows inches behind the surface frame, to volumes of glass that protrude inches from the surface.



The Orange Cube in Lyon, France by Jakob + MacFarlane Architects (completed 2011), achieves the effect of considerable depth of surface by layering a perforated

aluminum screen (with a bubble pattern suggesting the river's proximity) and external window shades, all of which cast shadows on a wrapper of steel and glass

panels on a concrete frame. The solar heat is controlled through these layers, while the giant conical holes facilitate air movement through the structure.

## Interfaces

A building's exterior surfaces are, in effect, interfaces between outside and inside, public and private, between the population of a city and the occupants of a building. The surfaces and the various membranes of which they are composed help to keep the occupants warm or cool, prevent the penetration of precipitation, control sound levels, modulate the penetration of light, provide for the privacy of those inside, frame views, provide access, and facilitate egress. Depending on a design's functions—theater, bank, farmers' market, prison, courthouse, department store, and so on—the surfaces of a building may be required to perform additional duties, such as to display the interior to a large audience outside its volume, communicate the building's function, propose its potential occupation, suggest security or permanence, or to invite or dissuade entrance.

As interfaces, the surfaces of a building may contain numerous layers. The outer layers

express the public face of the building while confronting its numerous environmental conditions. Inner layers may include structure, mechanical systems, and insulation. The most interior layer may express the specific requirements of various interior spaces, providing utilitarian amenities and comfort to the occupants. If the outermost surfaces are required to provide the greatest visual effects of a building's designed intentions, the innermost layers of a building's surfaces are often those that are engaged most *tactilely* by the users.

## Performance

All exterior surfaces of a building—roofs, walls, foundations—are obliged to prevent weather from rendering a structure unusable, whether through rot, insects, the penetration of moisture, inhospitable temperatures, and so on. At the same time, these surfaces must often also be able to breathe: to allow gases and moisture (often in the form of condensation) from within the building and its walls to

penetrate outward. These surfaces might also breathe in that they may be required to control natural ventilation and heat gain from direct solar penetration.

In order to more effectively control solar penetration of a building, both for environmental purposes as well as for privacy and the control of views, the exterior surfaces of a building may often be composed of screenlike components. These screens may take many forms, such as concrete brise soleil, perforated metal panels, or even computer-controlled arrays of louvers. Screens can provide a building with something like an exterior armor, rigid and impenetrable, or a floating veil, translucent and elastic.

The enclosure of a building is its primary contact with an exterior. Like clothing, its role is protection—of the building's occupants, interior finishes, and often its structure—while offering an insight into the personality it projects.



# materials

**Materials, both natural and artificial, retain traces of their origin, and they communicate intrinsic qualities that evoke associations and responses in their perceivers.**

Materials are an architect's instruments. When a composer writes a piece of music, it makes a considerable difference if it is to be written for a solo piano, a string quartet, an orchestra, or a marching band. Similarly, an architect's choice of materials has a profound effect on both the form of the work and its reception by an audience.

A material's behavior bears witness to its interaction with a variety of both ephemeral and physical contexts while its properties inform its constructive processes: its fabrication, transformation, potential perforations, types of apertures, and the details of its interactions with other materials within a construction and its environment. Materials, both natural and artificial, retain traces of their origin, and they communicate intrinsic qualities that evoke associations and responses in their perceivers.

### Characteristics

A material is often identified with its sensorial capabilities, which in turn inform how a space is perceived and how a surface performs.

#### *Phenomenal*

Intrinsic to each material are its physical attributes, which can perhaps best be described by a series of pairings—thick or thin, opaque or transparent, matte or reflective, dark or light. It is the qualities of these attributes that suggest meaningful associations with not only the program of a work, but also its perceptual experience. A wall made of glass might appear to dissolve the boundary between public and private, or inside and out, but it can also convey a crisp brittleness and a reflective hardness that suggests an atmospheric serenity. Of course, the manipulation of this very same material—tinting, screening, sandblasting, for example—can easily reverse these characteristics, and it is in exploiting these reversals that a material's capability to expand its programs and perceptions is often discovered.

*(continued on page 94)*



Overlooking Lake Lucerne in Meggen, Switzerland, stands Pius Church designed and built by Franz Füg between 1964 and 1966. Here, marble, a typically opaque material, has been thinly cut to just over 1-inch (2.5 cm) thick to produce a surprising translucency, demonstrating a characteristic that is not normally associated with the

material, but one that brings unexpected programmatic (stained glass windows) and perceptual (illumination) associations. The work exploits marble's potential as a material that can simultaneously demonstrate multiple characteristics: from the exterior, it is a cubic rock by day and a lantern by night.

# Material and “De-Material” in the Architecture of Herzog & de Meuron

The Swiss firm of Jacques Herzog and Pierre de Meuron, has been based in Basel since 1978. While their designs favor basic, easily recognizable volumes (traditional house forms, simple boxes), their provocative and unfamiliar usage of materials has consistently altered our understandings of the role materials can play in an architectural work. Herzog and de Meuron consistently deprive materials of certain of their expected properties, leading the observer to experience aspects of the building's ambitions that would normally be obscured by the “grip” of the material's more familiar usage.

As is already clear in their first Ricola warehouse, it is very common for the “language” of materials to communicate through several modes of signification. The scale and detailing of the material not only suggests similar constructions, such as the wooden tobacco barns throughout the U.S. that fascinated Herzog, but the horizontal layering of panels reflects the horizontal layers of limestone immediately adjacent to the building. The use of materials can suggest a function: In this case, the dense storage of goods is represented in a building that looks as if it were, itself, a pile of stored wood. At the same time, the violation of some of the material's expected traits serves to signify a deeper sense of the building: The “wood” is actually cement panels; its “stacking” is accomplished through loose attachment to a frame; its “solidity” is actually highly permeable.

In the Stone House in Tavole, Italy, the dry stone masonry walls at first suggest the other stone houses of the village, as well as the retaining walls that shore up much of the hill town. Thin concrete bands divide the walls, apparently mere traces of an organizing geometry that connects the



Herzog & de Meuron: Stone House; Tavole, Italy, 1985-88

house with its site. It appears to be a decorative touch, elaborated by the apparent absence of the concrete on the corners. In reality, the concrete is the structure, with smaller columns tucked within the corners. The dry masonry walls play no structural role, being instead exactly what they appear to be: a film of lightly stacked stones collected from the area. While the apparent lightness of the concrete leads us to believe that it has no structural value, the apparent massiveness of the stone suggests structure. The house leads us to question our material prejudices, referring to the traditional usage of materials while drawing us into new, unexpected impressions. A material seduction begins to occur.



Herzog & de Meuron: Ricola Warehouse; Laufen, Switzerland, 1987

Herzog and de Meuron's most recent work seems to employ more subtle modes of material manipulation: materials such as stone, metal, and concrete develop unexpected textures, and these fundamentally opaque materials join essentially transparent materials, such as glass and plastic, in beginning to assume a quality of translucency and reflection.

For example, the gabions that line the exterior walls of the Dominus Winery in Yountville, California, at first produce the image of a massively rusticated country wall. Gabions—wire mesh cages usually containing rough stones collected on-site—are traditionally used for retaining walls, most familiar for their usage in highway construction where their strength seems to be equated with their apparent solidity and opacity. At the winery, however, Herzog and de Meuron have used the gabions as an exterior cloak, filling the cages with varying sizes of rock and, occasionally, with no rock at all. From the interior, glass walls behind the gabions take advantage of the dappled light that filters through the stones. What is understood to be solid and opaque is instead permeable and translucent.

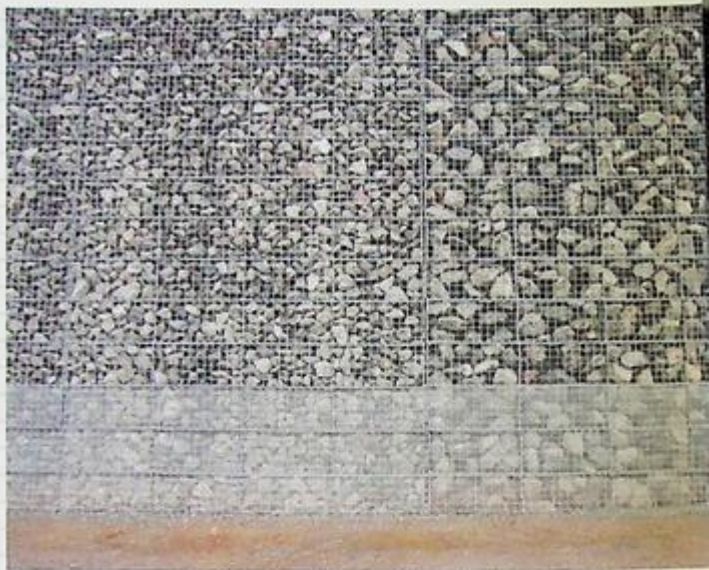

Herzog & de Meuron: Dominus Winery, Yountville, California, 1996-98

In the Laurenz Foundation art storage facility, the thick exterior surfaces of excavated earth panels with exposed pebbles propose a massiveness that protects its contents, both environmentally and in terms of security. Yet this massiveness is belied in several ways. A large, horizontal cut on two sides of the building is intentionally irregular, digitally derived and constructed to suggest enlarged pebblelike forms. Although this gash serves to demonstrate the wall's thickness, its horizontality simultaneously undoes the wall's mass. Then, as these apparently heavy walls make their way toward the street side, they seem to end abruptly, with a knife's-edge transition to a large, scaleless polygon of flat white surfaces that defy scale and deny material.

Subverting some of the traditional perceptions of a material lead to that material's perceived de-materialization, limiting a material's anticipated characteristics, while suggesting unexpected, previously unimagined traits that are often even opposite the initial impression. Herzog and de Meuron assume that material has no fundamental qualities, that "the quality lies in the work itself, where the material attains specific value that leaves bare materiality behind; ... [It] is no longer a purely representative means and therefore no longer restricted to the visible surface." Actually, in contemporary architecture, the immediately visible is perhaps the least reliable indication of a material's attributes, not only because of the capacity of certain materials to mime the traits of others, but

also because a project's physical characteristics are usually surpassed by its conceptual values. The architecture of Herzog and de Meuron, however, proposes a sensuality that can be discovered only through a thoughtful encounter with the work. We find architecture's intangible values firmly rooted within our experience of materials.



Herzog & de Meuron: Laurenz Foundation Schaulager;  
Basel/Münchenstein, Switzerland, 1998-2003

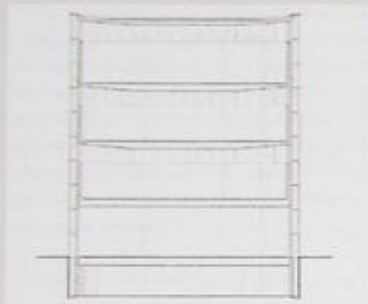

Walls of scalelike glass shingles envelop an interior of cast concrete 'drawers' in Peter Zumthor's Kunstmuseum in Bregenz, Austria (1990-97). The contrasting materials produce an atmospheric dialogue that shifts between

the reflective and translucent exterior lantern to the stark and cold of the concrete of the gallery spaces. The two are brought into focus as the light filters in through the plenum areas and the polished concrete galleries begin to glow.



The walls of the Kunstmuseum in Vaduz, Liechtenstein, by the Swiss architects Morger and Degelo, with Christian Kerez (1997-2000) are of cast concrete, and it is the sanding of their exterior surfaces that reveals its composition:

basalt, nearby Rhine river gravel, and black cement. The result is a highly polished surface that reflects the surrounding buildings, connecting the building with both its built and geological contexts.

#### Textural

Materials can develop textures through their installation, manipulation, finish, and wear. These textures have significant impact not only on a material's durability, penetrability, and usage, but also on the distinctness of space and surface. If cast concrete is highly polished, it can virtually disappear as it reflects the environment surrounding it. Or its normally hard, inelastic surface can be softened through the imprint of the traces of its forming. Or if it is subdivided into individual blocks, it can be stacked into a porous screen. The texture of a material can determine the sharpness or blur of a shadow, can suggest the finite or infinite impressions of a space, and can tempt or inhibit the tactile engagement of a surface.

#### Acoustic

Materials can be acoustically hard or soft; they can cause echoes or muffle voices. An acoustically reverberant space can appear to be exaggerated in its vacancy or in the grandness of its scale. A space that is acoustically absorbent can be perceived as more intimate, more comfortable. The materials of a floor or path can make our

steps seem stealthy or monumental, modest or emphatic, unobtrusive or processional. The acoustic traits of materials can inspire associations related to memories, perceptions, and even other arts such as film or music.

#### Permeability

The way a building can weep or breathe is an important and even necessary aspect of the selection of materials. The permeability of materials—especially those used in the exterior membranes of a building—can keep a structure and its components dry or humid, hot or cold, fresh or musty, even light or dark. As a result, a material's degree of permeability has a direct relationship to all of the above material characteristics.

#### Behaviors

It would be a mistake, however, to consider the nature of materials as being permanent and unchangeable. An understanding of the behaviors of materials not only plays an important part in protecting the integrity of a construction and ensuring the quality of life of those within, but it can also contribute significantly to the aesthetic qualities of a building.



Texture is the material of Heatherwick Studio's Seed Cathedral built for the 2010 Shanghai Expo. While the primary structure is a wooden box, 40,000 clear acrylic rods intersect its surfaces, blurring the boundaries between building and sky. 250,000 seeds are embedded

into the tip of the rods, which are illuminated by day as the sun shines through and, at night, by light sources embedded in each rod. The swaying of the rods in the breeze is a material expression of its program: the seeds growing into a field of wheat.

Herzog and de Meuron's Ricola-Europe production and storage hall built in Mulhouse, France (1992-93), is a concrete box with a northern face that opens up as if to expose the strips of polycarbonate panels at its entry façade. The building's drainage has been intentionally choreographed to spill down its matte concrete surfaces and it is these newly striated surfaces

that enable the concrete to take on the characteristics of the adjacent polycarbonate façade. This intentional engagement and registration of temporal aspects of the environment allows these unrelated surfaces to be brought into material conversation, temporarily transforming the concrete volume into a glistening crystal.



Simon Ungers's T-House, Wilton, New York, built in 1992, is a project that blurs the boundaries between architecture and sculpture. Its fundamental geometry and the relentless use of weathering steel suppress all detail and scale, reinforcing the notion of the building as a sculpture. Steel is also used as a functional material capable of accommodating

the extreme cantilevers of the raised library block. The house's dimensions are determined by its mode of transportation: It was constructed off-site in a factory, brought to its site on eighteen-wheelers, and assembled in situ. Over time, the steel has rusted to a dark brown, its weathered surfaces merging with the forested landscape.

### Responsiveness

Very few materials are entirely static. Most respond in a direct way to the stresses of gravity, heat, cold, moisture, and so on, albeit in varying degrees. Some of these responses can be permanent, as with cracking or erosion, while others can be cyclical, as with expansion and contraction or flexing and straightening. Recognizing these behaviors, not only at a material's various scales and dimensions but the *interaction* of these behaviors among different materials, is critical in accommodating these inevitable transformative behaviors.

*Weather, or the inevitability of transformation*  
All materials have a lifespan, but how a material transforms over time is unique to its composition and to its interaction with a specific weather and environment. It is important to understand that the end of the construction process is but the beginning of a course of weathering and entropy, most of which can be anticipated. At the very least, most materials change color or texture when wet. However, some materials are much more reactive, with transformations that can be

quite pronounced, as in the case of copper as it changes from reddish brown to green, with weathering steel as it oxidizes to an earthen rust, or with cedar as it weathers from a reddish brown to gray. Less predictable is the staining and eventual erosion of more resistive surfaces that allow initially untainted materials to slowly fade into their surrounding context, to return to the earth. Mohsen Mostafavi and David Leatherbarrow speculate on the *intentional* deterioration of a funeral chapel, "... used deliberately as a device for marking and infecting the purity of the new building surface, ... as the possibility for showing the life of the building in time." (Mostafavi and Leatherbarrow, page 103.) Anticipating such material transformations is a significant aspect of the design process.



Through the use of thin-film photovoltaic textiles, KVA's 2007 Soft House transforms the prosaic curtain into an energy-harvesting textile that can generate and distribute up to 16,000 watts of renewable electrical power.

Translucent, movable curtains convert sunlight into energy throughout the day while facilitating changing spatial configurations. Parametric design software developed for the Soft House project allows the homeowner to

customize the energy density of the textiles according to need and guides the relationship of building form to site: Technological invention produces the spatial experience.



Inspired by homeostasis in biological systems (a system that regulates its internal environment and tends to maintain a stable, constant condition of properties such as temperature) Decker Yeadon's Homeostatic Façade System regulates a building's climate by responding to environmental conditions.

It does so by using a simple actuator, or artificial muscle, to transfer electric energy directly into mechanical work. The façade's silver-coated ribbons automatically deform in response to heat, increasing their surface area and thereby preventing thermal gain and reducing energy consumption.

### Smart materials

Smart materials are materials that are designed to actively perform, whose shape or properties change in response to an external stimulus. Michelle Addington explains that smart materials design behaviors, with the actual materials being secondary to the effect that they produce. These behaviors are programmed into the material's composition and when activated (by for example temperature, moisture, electricity, or stress) the material's functionality is transformed, allowing it to perform in or adapt to a particular set of circumstances. The use of smart materials alters our understanding of materials from being static elements that are meant to withstand one or more predetermined environments to being animate substances that have the potential to engage continuously changing environments and are fully capable of reconciling the body with its cultural and physical environments.

Similarly, nanotechnologies provide us with the ability to manipulate material at its atomic and molecular scales. The material scientist Michael Cima speaks of simultaneous fabrications in which multiple programs are embedded within a single material structure. Like a hearty stew, various predetermined material properties (such as transparency, acoustic properties, strength, warmth, and illumination) might be layered into the 'process of their fabrication,' introducing an interactive programmatic complexity to a single composite material. These nanocomposite materials not only improve material strength and performance, but recent exciting research reveals a potential for introducing multifunctionality into singular building surfaces.



David Adjaye's Genesis pavilion installed at the Design Miami 2011 fair is constructed of hundreds of equally dimensioned wooden timbers. Floors, walls, and ceilings are created out of the same material increment, and it is the manipulation of the spacing between these planks that allows for the various programs of sheltering, structuring, entering, framing, viewing, screening, and reposing.

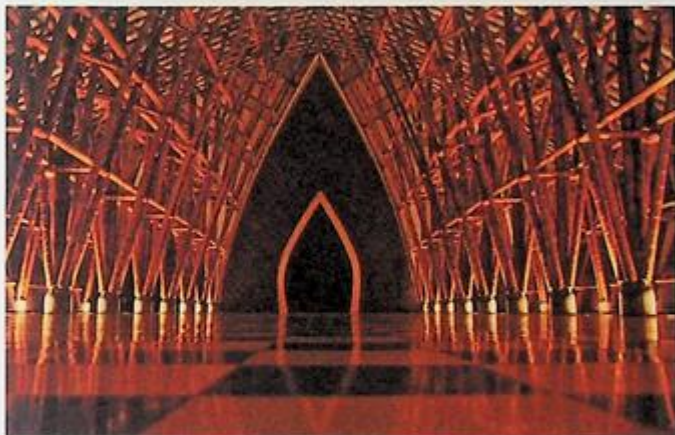

Bamboo is highly regarded for both its material behavior and sustainable properties. Its usage is directly related to the method by which it is processed. Its stems can be bundled, cut, split, flattened, twisted, woven, and laminated, each process lending itself to a unique constructional process. Simon Velez's "Church without Religion" in Cartagena, Colombia, exploits bamboo as structural armature, a frame-like lattice of bamboo rods that tethers the building to its site.

Yet a temporary church in Yogyakarta, Indonesia, (right) demonstrates a decidedly alternative application. Here, the architect Eugenius Pradipto transforms bamboo into a series of flattened shingles that wraps the church's structural framework. In both of these examples, bamboo is alternatively exploited as both structural framework and porous skin.



### Constructive Processes

Constructive processes are often a function of a material's properties and of their intrinsic dimensional standards and limits, which can, in turn, greatly influence its usage and how it might be detailed. These processes are equally a function of the location of the project (ease of accessibility, the expertise of those building it) and affordability.

### Manufacturing Methods

The dimensional limits of a material are either determined by its natural state or imposed on it by the manufacturing processes used to transform a material from its natural state into a useful building material. This link between origin and application can be exploited in projects where a material's dimensional increment, either in its natural state or as manufactured, is consistently registered while accommodating a variety of programmatic and environmental concerns. For example, the densification or expansion of a particular dimensional increment can alter a surface membrane's porosity or provide the logic for the operation of its apertures.

Manufacturing processes not only inform a material's dimension but can also demonstrate a unique characteristic or behavior. For example, a quarried block of granite can be cut into monolithic blocks or sliced into thin slabs—the one producing the effect of a massive wall while the other, a thin membrane. The exploitation and exaggeration of these processes can be a powerful tool in the development of an architectural concept.

Massimiliano Fuksas's Museum of Graffiti in Mieux, France, completed in 1993, is located in an extreme site on the side of a hill and at the mouth of a subterranean passage that leads to prehistoric cave paintings dating from 11,000 BCE. The difficulties of access required the on-site assembly of steel components that had been precariously transported up a small access road. Not only does the rusting of the

weathering steel components protect the structure and minimize the necessity for maintenance, but their apparent weightlessness is suggestive of the delicacy of the cave drawings to which the pavilion provides access. The line of the cave drawing is conceptually extended out to the face of the mountain, erupting into a three-dimensional expression of the two-dimensional drawings deep within the mountain.



#### Assembly

Site access, methods of transportation, and builders' expertise can further inform material choices. Transportation and site access can limit the dimension of materials that can be delivered to a site, which will then either require on-site assembly of smaller components (that have been fabricated elsewhere) or demand on-site fabrication. In these extreme sites, an understanding of local or traditional construction practices can inform material choices and construction processes.

#### Detail/Jointure

Materials undergo various degrees of change as they react to environmental conditions (gravity, temperature, erosion, and pollution) or as they react to other materials (corrosion and staining). Strategies for addressing these changes are often demonstrated at the intersections between adjoining materials. For example, each material responds to tempera-

ture variations by exhibiting a unique range of expansion and shrinking behaviors. As one material meets another, these behavioral differences must be acknowledged either through not letting the two materials touch, as in a "reveal" (a small gap left between the materials), by allowing the materials to overlap so that they can move independently or by inserting a third material that can mediate two materials' distinct behaviors.

Differences in dimensional precision between materials that are fabricated using precise tools (as in steel fabrication or wood cabinetry, for example) versus those that are fabricated on-site using less controllable technologies (as with poured-in-place concrete) can also be accommodated by a reveal, or by introducing a third material that can accommodate the differences between the two (for example by inserting a piece of cork between a precisely milled wood and a rougher concrete surface).



The glass panels that enclose Sverre Fehn's 1973 Hamar (Norway) Bispegaard Museum float slightly away from the thick exterior stone walls of the existing barn. This detail negotiates the distinct dimensional differences between the manufactured crisp glass edges and the fluctuating

stone profile, while permitting some of the weather into those parts of the museum where controlled climate might be dangerous to the artifacts. The detail also reinforces the primary concept of the project, that of a series of material and historical layers.

Chamber music was written to be performed in intimate spaces, often made of wood. The interior of the Sala Suggia in OMA's Casa da

Musica in Porto, Portugal, 2005, though of another scale, refers to that tradition and the resonant qualities of a wooden music box.

## Indices

Materials carry *meanings* through embodying traditional materials, methodologies, and rituals of construction as well as through the less tangible aspects of the uniqueness of place, program, and culture.

### Site

A material often operates as an index to a particular site. The use of wood from a local forest not only inextricably links the work to its immediate physical context but to those projects that share a similar material source. The ways in which materials are connected to each other can further reiterate a context by referring to traditional building techniques.

### Program

Often, the performance requirements of a particular function will motivate material selection. A wood railing carries with it material warmth that is smooth to the touch, or a stone staircase will withstand centuries of wear.

### Cultural

Materials often carry symbolic expectations, as in a granite tomb or a marble city hall or a wood cabin. Granite implies eternity, marble alludes to grandeur, and wood to a natural primitiveness. It does not necessarily mean that all tombs should be granite, but it is important to be aware that traditional associations exist, and they may be unique to each culture in which a work might be situated.

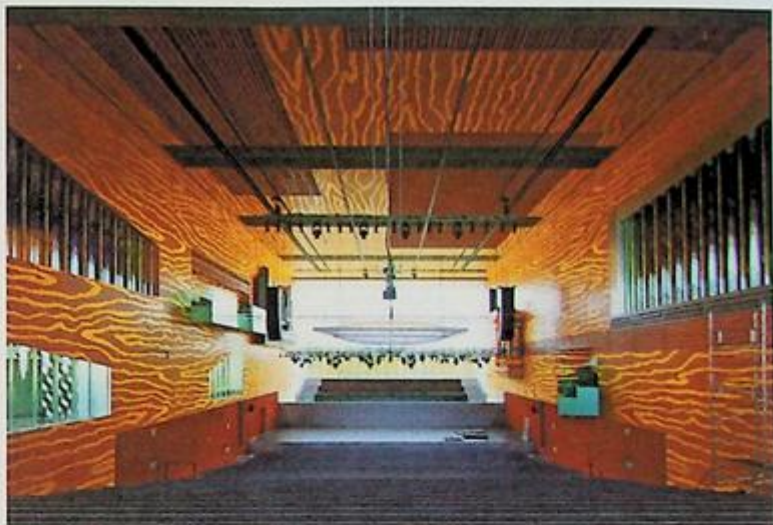

Blocks of locally hewn granite form the cubic mass of Ensemble Studio's Musical Studies Center in Santiago de Compostela, Spain, built in 2002. The hydraulic drilling techniques related to the stone's extraction are expressed and celebrated on

its surfaces, transforming a prosaic and unremarkable constructive detail into an essential ornamental motif. The material is converted into a didactic tool, an index to a fast-disappearing quarrying technology.



# space

**Space may be the principal defining characteristic of architecture and what distinguishes it from the other arts.**

Wallace Stevens's poem, *The Snow Man*, concludes with what might be a good definition of the distinction between a *void* and what might be considered architectural *space*: the "... Nothing that is not there and the nothing that is." If a void is the nothingness that is absent, space might be understood as the nothingness that is present.

As Constantinos Doxiadis has famously diagrammed in his *Architectural Space in Ancient Greece*, one can understand the organization of the structures of the Acropolis as being based on a series of uninterrupted visual scans, radiating from a position at the portico of the

Propylaea at the entry to the complex. This conception of space might be described as a "site of perceiving," in that the objects arrayed about the Acropolis are perceived in their relative positions—horizontally and vertically—as distributed across the site.

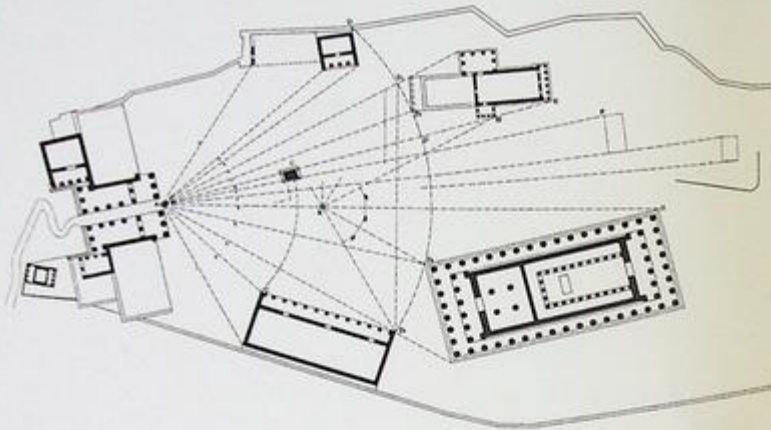

Architectural space provides the range across which our gazes pass before resting on objects, surfaces, and other people. Space encompasses the stage for human activity, the cadence of our movements, the duration of our experiences. Space contains that which is within our physical grasp and that which may be "graspable" only through perception, comprehension, and memory.

It was probably August Schmarzow who, in 1898, first argued that the manipulation of space is the principal defining characteristic of architecture and what distinguishes it from the other arts, such as sculpture. This is not to say that architectural space did not exist before 1898—certainly the Pantheon exists as an emphatic spatial volume—only that its identity had not been adequately described.

There is also that conception of space as a "site of perceiving." In this sense, space is the range within which a person, located at a point, apprehends his or her environment, actually *constructing* this environment based upon prior knowledge, experiences, and techniques of observing.

(continued on page 104)



Giambattista Nolli's 1748 map of Rome is remarkable not only for its accuracy, but it endures as an example of the spatial equilibrium that occurs during the experience of a city. The contrast between the darkened fabric of the city and the white, figural spatial elements

elegantly demonstrates the way that public exterior spaces—such as piazzas and courtyards—and public and semipublic interior spaces—such as the Pantheon and various churches—became equal participants in establishing a pedestrian's perception of a city.

# “Phenomenal Transparency” in the Spaces of Le Corbusier

In the twentieth century—the century roughened by unimaginable wars, yet emboldened by velocity, stream of consciousness writing, nuclear fusion, motion pictures, jazz, Futurism, and Cubism—there was an impulse to construct a concept of space that was as unique to architecture as the century was to its predecessors.

Sigfried Giedion's *Space, Time, and Architecture*, based on a series of lectures given at Harvard from 1938–39, proposed a formulation of Einsteinian space-time as an intrinsic aspect of the new architecture. Although ultimately more of a metaphor than a scientific validation, Giedion's theory introduced Cubism as a form of spatial research, with important architectural implications.

Bruno Zevi's *Saper Vedere L'Architettura* (1948, translated as *Architecture as Space: How to Look at Architecture*) came later, arguing that the history of architecture was largely a history of architectural space, by which he meant especially enclosed space. Like Giedion, Zevi also argued that time was an important component of the newer concepts of spatial definition, incorporating the experiments of the Italian futurists, for whom speed was a Muse. He promoted a version of “organic architecture,” a compilation of theories founded on gothic architecture and the work of Frank Lloyd Wright, stressing spatial ambiguity, with an indefinite flow of spaces often crossing functional boundaries.

Then, combining their expertise in architecture and the fine arts, Colin Rowe and Robert Slutzky's *Transparency* (1955), proposed a more articulate argument regarding

the spatial implications of modern art and of Cubism, in particular. Based on Gyorgy Kepes's notion—presented in his *Language of Vision* (1948)—of the Cubist-based phenomenon whereby two or more overlapping figures claim the overlapped zones with equal priority (as opposed to the foreground figure occluding the background), “transparency” connotes “a simultaneous perception of different spatial locations,” imparting a continuous oscillation of spatial definitions. Rowe and Slutzky introduce the distinction between literal transparency—which simply involves a clear layer, as vision through a film—and phenomenal transparency, in which multiple and simultaneous spatial interpretations are evoked, and “the transparent ceases to be that which is perfectly clear and becomes instead that which is clearly ambiguous.” (page 23) And Rowe and Slutzky find that such “clearly ambiguous” transparencies are especially evident in the work of Le Corbusier.

The view from the terrace of his Villa Savoye in Poissy (1928–31), for example, affords numerous such spatial transparencies (fig. A). Beneath the roof of the outdoor pavilion, one already participates in several spaces: that of the pavilion itself, of the exterior spaces, and of the shaft of space that moves directly into the house (see the blue zones, fig. B). A band at the horizon line (yellow/orange) extends from the terrace through the interior, circumscribing the peripheral “frame” of the house; and a large exterior space (reddish) open to the sky moves from the center off toward the right. Figural, in a more painterly way, is the band of greenery (green, fig. C), which begins beyond the house on the left, visible



Le Corbusier and Pierre Jeanneret: Villa Savoye, Poissy, France, 1928–31

through the horizontal slot and then above the roof, to emerge both upon the terrace and on the roof above; both outside and within the volume of the house, the greenery's ambiguous presence is emphasized by the setlike walls (orange) that alternately act as frame and backdrop.

Here, one finds the spatial depiction of the twentieth century fully realized.

Just as a street can exhibit spatial qualities, both formal and experiential, an arcade is perhaps the most spatial form of street. Developed primarily in the early nineteenth century, arcades utilized the previously inaccessible inner blocks of large cities, increasing the quantity of commercial properties while providing safe routes independent of the crowded streets. In Paris,

where there was once over 130 arcades, the very successful Passage des Panoramas (bottom of plan, 1799) was followed by the first metal and glass arcade in the city, the Passage Jouffroy (center and photograph, designed by François-Hippolyte Destailleur and Romain de Bourges, 1845), and the Passage Verdeau (top, 1847).

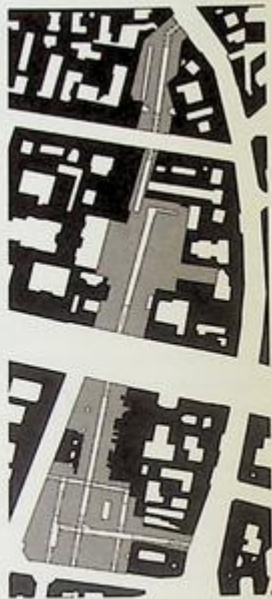

### Spatial Zones

One of the most important aspects in the formation of architectural space is the concept of *definition*. Just as the space within a deflated balloon is difficult to grasp, and that within an inflated balloon is clearly intuited, in order to grasp a spatial figure—or spatial zone—a sense of boundary is necessary.

However, it is possible that several spatial zones might overlap, and that it is possible to occupy several of these zones simultaneously. The complexity of such spatial overlaps is resolved perceptually, with the viewer understanding one set of boundaries at a time, perceiving additional zones through movement and shifts of viewpoint.

We can usually understand the relative dimensions of height and breadth simply by standing within a space. Depth, however, requires at least some movement into or around that space. This movement permits us to extrapolate approximate depth, based on our understanding of the relative locations of surfaces and objects within our angles of vision as we establish focus and understand our movement in relation to time. Because movement across a distance is an essential facet of spatial experience, many theorists find that time is an inextricable component of space.



Artist Rachel Whiteread's *Ghost* (1990) is the solid casting of the interior of a London room. One can see the imprint of the fireplace

and the protrusion of the hearth in the foreground. Essentially, *Ghost* is space made solid.



In this plaster model from his "Structures and Sequences of Space" in Spazio 7 (1952-53), Luigi Moretti constructs as solid the principal spatial sequence in the interior of Guarini's baroque

Church of Santa Maria of the Divine Providence in Lisbon, Portugal (shown in partial plan on the left). The solidification of space makes its intangibility immediately graspable.

One of the most effective methods of promoting the understanding of depth is by means of the rhythmic organization of surfaces: the columns lining a cathedral's nave, the beams of a ceiling, or the patterns in a floor. The measures of repetition are essential in understanding the depth of a space.

While traditional architecture generally establishes spatial organizations axially upon our introduction to a space, modern architecture would often promote entry into the corners of spaces, so that our first glance would be diagonal. In order to emphasize this concept of spatial depth, architects such as Le Corbusier frequently utilize the "long dimension," essentially the diagonal view that penetrates a space or across multiple spaces.

### Spatial Illusion

The development of linear *perspective* affected many aspects of architectural design. It altered the ways in which space was represented in architectural renderings. It provided architects with a tool for understanding what might be visible (or hidden) from specific points of view. The mechanisms of perspective—horizon, vanishing point, picture plane, and pyramid of vision—not only assemble an illusory space within a frame, but also "locate" a viewer in a space constructed in front of the frame: the viewer becomes an implicit subject of the work.

Linear perspective also permitted the actual construction of illusory space in architectural design. While height and breadth are clearly



Pietro da Cortona's design for the exterior of Santa Maria della Pace (1654–67) presents a facade that suggests a round, temple-like object nestled within a semicircular concavity. Located in a very confined alley in Rome, the architect, a master of illusionistic perspective, uses forms composed of elliptical objects in various degrees of

compression, all within a depth of just 5 to 10 yards (4.5 to 9 m). In this low relief model by Jonathan Negron (faculty, Jerry Wells), one can easily understand the spatial depths implied by the warping, overlapping, alternatively convex and concave sequence of mildly curved surfaces.



Renaissance artists would often supplement constructed perspectival depth with gridded surfaces, such as paving patterns and ceiling coffers, as in Piero della Francesca's *Flagellation of Christ* (c. 1457). The repetition of a grid of squares receding in depth assists in the location of figures within an illusory, and symbolically

charged, three-dimensional space. The low horizon, the strangely located vanishing point, and the clear distinctions and resemblances between the foreground and background scenes not only contribute to interpretations of the painting's themes but also serve to imply the viewer's location within the space in front of the painted panel.

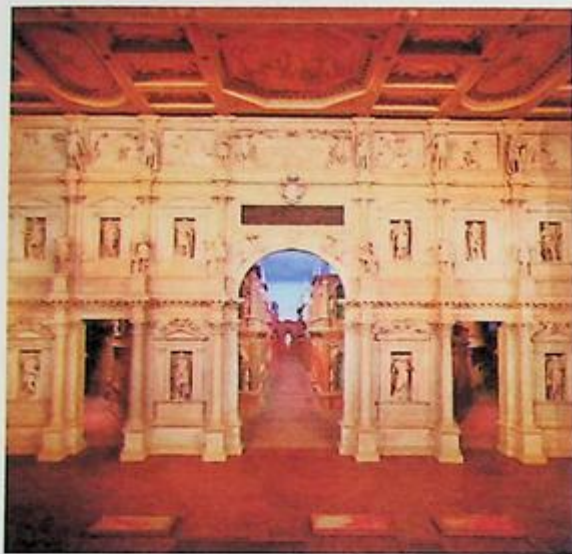

understood when viewing a surface, an object, or into a volume, the spatial dimension of depth can potentially be constructed through more painterly means: through the visual illusions of a perspective construction combined with the memory's allusions to previously experienced spaces. This is a technique that was developed most effectively in the architecture of the late Renaissance and baroque periods, where one can find numerous examples of relatively flat or gently molded surfaces invested with waves of implicit depths.

Building on these developments, a new form of perspective—the *panorama*—was developed in the late eighteenth century. Rather than simply present an illusory depth on a flat surface, the panoramas of the nineteenth centuries enveloped their audiences with their massive scales, multiple vanishing points, and epic themes, transporting their viewers into the midst of another time and place. Buildings that housed these artificial worlds—often

themselves called panoramas or cycloramas—appeared in cities throughout Europe and the United States, and are continuing to be constructed throughout Asia. As a tool, panoramas changed the way designers could see and interpret urban space, allowing the viewer to move casually through a 360-degree environment.

Eventually, panoramic paintings gave way to similarly constructed photographs, and finally panoramic cinemas developed popularity, although all forms are currently being revived as interest in immersive representation is increasing. The rapid development of video games, in which the viewer is an active participant in a virtual three-dimensional

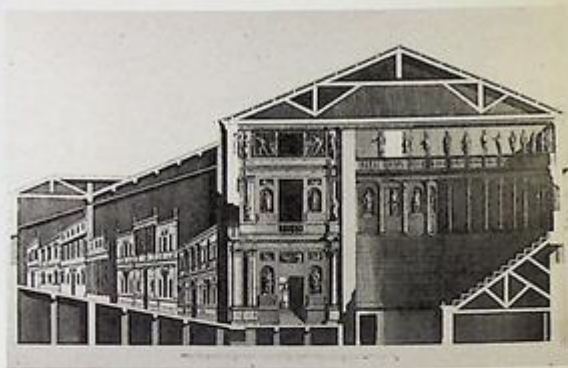

Vincenzo Scamozzi's set designs for *Oedipus Rex* (1585), have been permanently installed since the inaugural production in Andrea Palladio's Teatro Olimpico in Vicenza. Constructed in a false perspective, the sets represent the seven roads of Thebes within the relatively limited depth of

the theater's backstage. From the abstract interior space of a theater that evokes impressions of a grand outdoor amphitheater, one looks into the spaces of an idealized and imaginary ancient city, to eventually return to the real streets and spaces of Vicenza as perceived through fresh eyes.



The Lower Roadway of New Jersey Route 139 (William Sloan, Fred Lavis, Sigvald Johannesson, and the New Jersey State Highway Commission, completed in 1929)—born of the postwar necessity for the efficient, exclusive accommodation of vehicular traffic—was unprecedented in scope and

design. This sunken roadway is naturally ventilated and lit, open to the sky along its northeast edge, with its southeast flank a series of arcades exhibiting, sequentially when leaving the city: a chasm of concrete light wells, rough rock formations, and impromptu thickets of trees. Listed in the National Register

of Historic Places, it is a unique spatial invention—a cathedral of sorts—a deeply beamed concrete nave alternating stroboscopic shafts of daylight with the ghosted diagonal traces of cross streets above and a series of rugged “side chapels” casting variegated light onto the roadway.

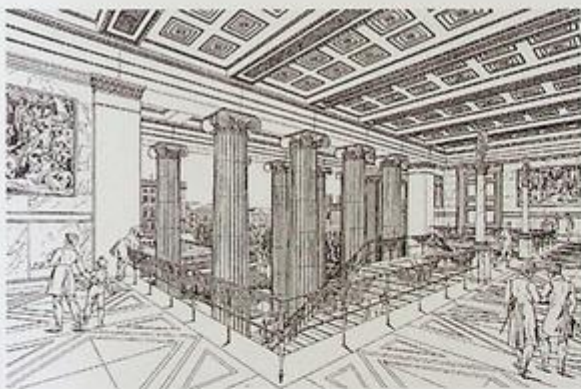

Karl Friedrich Schinkel was highly skilled in the constructions of panoramas and illusionistic stage set designs, and, as historian Kurt Forster has demonstrated, applied this knowledge to his architectural designs for Berlin. For Schinkel, the

mobility of the viewer around and through an urban space with frequent opportunities for retrospection is an important aspect of spatial organization. His famous 1831 rendering of the main staircase of his Altes Museum shows figures ascending from

below, then strolling through the upper vestibule, which provides a vantage point as in a panorama: elevated above the plaza, with columns framing fragmented views of an urban panorama of an ideal Berlin that vies for attention with the works on exhibit.

environment, complete with aural and additional sensory (haptic) effects, will certainly influence both the interactive nature of modeling and presenting architectural projects, and the development of spaces in which the mobility of the viewer is an integral factor.

In the early twentieth century, people were exposed to spaces that were previously unthinkable, spaces initiated by internal combustion, witnessed through auto glass and dedicated to velocity, the combination of distance and time. New concepts of spatial definition emerged, enveloped in structures of heroic massiveness and rhythms of increased rapidity. New types of architecture appeared, not only highway constructions themselves, but also the buildings and spaces that began to materialize along these new roadways, such as toll plazas, rest stops, fueling stations, and so on. Perceived at high speeds and sited on or along roadways, these buildings address the highway and its expanded vistas with spaces configured by rates of acceleration and deceleration, vehicular turning radii, driving lanes, and viewing pyramids constrained by automotive design and increasingly favoring the oblique over the frontal. The result is an elongation of spaces and the development of an anamorphic architecture, one in which landscapes, spaces, and volumes are distorted in compensation for the visual foreshortening and condensed observations prompted by the highway.

# 12

## scale

**Scale can be fleeting or even imaginary, relational or perceptual.**

Size is how big something is—its actual dimension. However scale is relative, it can be defined only in relation to something. That something can be the whole—in other words, a door has a scale in relation to the surface in which it is located—or the perceived, as in the position of the observer, from where (what



Álvaro Siza's Santa Maria Church in Marco de Canavezes, Portugal (1996), manipulates scale in relation to multiple contexts. From the square below, it appears to be a modest church atop a hill, with a traditional window indicating its nave (although this window is, paradoxically, unseen from the interior). Upon the hill, one finds the

entry door abnormally enlarged, at a scale appropriate to the ritual of procession. Once inside, a long, low horizontal window at the eye level of seated parishioners returns the structure to human scale, emphasizing the expanse of the horizon and the valley beyond.



distance, what orientation) he or she is located. Scale is dependent on context, a context that can range from the smallest nanoparticle to a vast landscape. Scale is fleeting, as a building for example can simultaneously belong to multiple scales. And, finally, there is the imagined scale—where the mythology of the object has established a scale greater or smaller than the actual. How many times have we come upon something that we have always read about or seen in images and think, "Oh, how much smaller (or larger) it actually is!" where its "reality," once contextualized, is vastly distinct from its imagined scale?

## BODY

The body is a powerful determinant of scale. It has the ability to generate measure through either its necessity to physically engage an environment at multiple scales and at multiple speeds (be it a handle, a car, a parade) or through locating its eye in relationship to that environment (a window, a vista) so that it can be perceptually experienced.

### Physical

The height of a stair riser, the height and profile of a handrail, the proportions of a chair are all scaled to interact with the dimensions of the human body. The body's

(continued on page 112)



The profile of Alvar Aalto's ceramic-clad volume of the 1968 Nordic House in Reykjavik, Iceland, is shaped simultaneously by the

acoustical necessities of the auditorium that it encloses and the mountainous silhouette of the distant Mt. Esja beyond.

Aldo Rossi's Teatro del Mondo, constructed for the Venice Biennale in 1979, endlessly manipulates our perception of the existing context. As this temporary structure literally floats into proximity with the city's great churches, their scale is suddenly transformed from monumental and massive to pavilionesque and fleeting.



# Gerrit Rietveld and the Scales of Art

“De Stijl” was the name chosen for the collective efforts of a group of loosely organized creative people in the Netherlands in the early twentieth century. The work of this Dutch group coalesced around the musings published in an eponymous magazine. During its brief period of publication, *De Stijl* showcased images of architecture, painting, sculpture, and furniture-making amongst literary musings that trended towards a heady sociocultural cocktail of transnationalist politics and universalist metaphysics. The second issue of *De Stijl*, published in 1918, set out the group’s manifesto. Painting was singled out as the seminal visual discipline capable of expressing a floating, unbounded spatial continuum. Initially, there was resistance to the inclusion of architecture due to its obligation to address structural and functional needs. The painter Piet Mondrian noted within the pages of volume five, “What was achieved in art must for the present be limited to art. Our external environment cannot yet be realized as the pure plastic expression of harmony.”

In the face of the skepticism of Mondrian and others, Gerrit Rietveld’s Schröder House was a remarkable achievement. The house forcefully made a case for the expressive capabilities of architecture and became a canonical representation of the spatial continuum admired by the De Stijl group. The interior and furniture of the Schröder House is beholden to the same conceptual thinking as the building shell. Walls on the exterior are simple rectangular surfaces that in many cases appear to float in defiance of gravity. Inside, walls are movable partitions (thus literally achieving the aspect of “floating” implied on the exterior). In the open position, interior partitions allow space to flow unimpeded,



Gerrit Rietveld: Schröder House, Utrecht, the Netherlands, 1923-24  
exterior and interior

creating territories of use in place of traditionally defined rooms. Throughout the house, rectangular surfaces are singled out at a variety of scales and finished in bright primary colors. This consistency of treatment extends from large architectural surfaces, such as a balcony wall, to small details, such as the end of a chair’s arm.

The Schröder House is a curated environment where a variety of normally disparate components—roofs, balconies, walls,



Gerrit Rietveld: Berlin Chair, 1923

windows, partitions, and furniture—are conceived and executed under a rigorously consistent regime. The geometry, surfaces, and color of all of these components were carefully considered and controlled by Rietveld. While providing a reasonably accommodating domestic environment, he organized the house as a singular declarative representation of the principles of De Stijl.

—Steven Fong (University of Toronto)

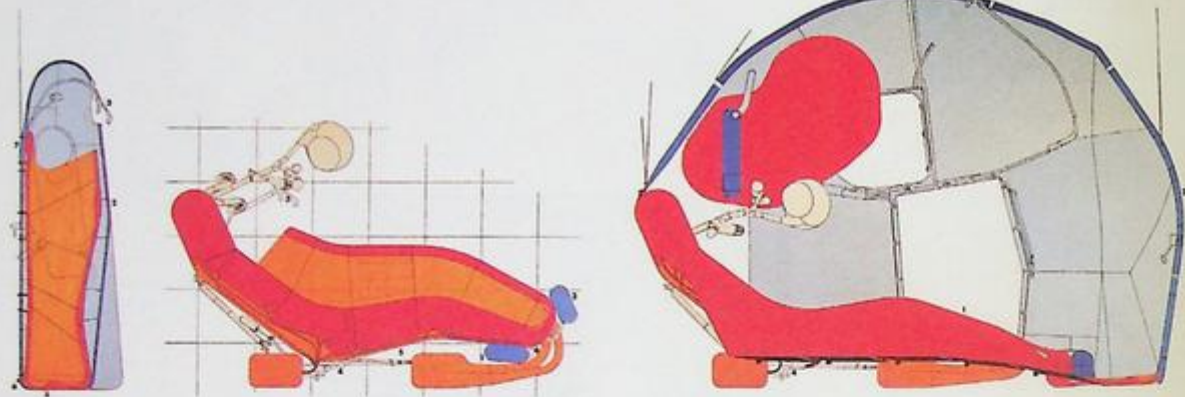

Michael Webb's 1966-67 Cushicle is a "nomadic unit" that provides self-sustaining functions to one individual. In its closed "skeletal" position, it is carried on a person's back and supports

its various appliances; in its open position, it is an inflated "domestic" skin. Both positions are scaled to the human body's proportions and range of motions.

proportions and range of motion determine the scale of physical form that operates as an interface between a body and its ability to comfortably occupy and navigate architectural space. This scale of engagement is most discernable within domestic spaces whose primary responsibility is to house the body and is critical in accessible spaces that accommodate specialized user needs (disabled, geriatric, children, and so on).

#### *Perceptual*

The eye of the observer locates the origin of the gaze that establishes both the horizon line and the cone of vision. As this gaze is superimposed onto an infinite picture plane, the near and the far can be brought into immediate relation to each other, giving scale to an otherwise scaleless environment. If site lines used in determining the locations and dimensions of apertures, frames, and



In Torino, Italy, the Fiat automobile factory, designed by Giacomo Matté Trucco (1921-28) juxtaposes two scales, one motivated by the movement and turning radii of an automobile test track, the other by the repetitive structural frame dimensioned by the large machines and assembly lines of the factory floor.



Conceived and perceived as two enormous rocks butressing the banks of San Sebastián's Urumea River, Rafael Moneo's 1991-99 Kursaal Auditorium and Congress Center exists at the scale of the surrounding landscape. Yet, as one enters the lobbies of each volume, a picture window frames that distant landscape, transforming the San Sebastián bay and the mountains of Mount Urgull and Mount Ulia into projected still lifes that appear to be drawn onto its interior surfaces.

12

Scale

grids through which views and light pass are carefully calibrated to the origins of both static and animate gazes, then these devices have the ability to register the scale of the human body. These foregrounds introduce scale to distant backgrounds and horizons by juxtaposing them alongside the scale of the body, establishing a tangible relationship between the human body and the context in which it is located.

### THE NEAR AND THE FAR

Buildings are eternal chameleons—they are shifty characters that thrive on belonging simultaneously to multiple and interlocking scales. As one views the Eiffel Tower from a distance, it is a marker, an orienting pin that protrudes from a once homogenous Parisian skyline. Yet as one approaches, its scale transforms to a monumental one, an upward thrusting demonstration of engineering ingenuity that dwarfs the observer. And finally, from within its rooftop restaurant, it is an instrument, a camera lens, scaled to the body, with which to frame the city below.



Adolf Loos's 1922 competition entry for the offices of the Chicago Tribune is, on one hand, a 120-meter (131 yd) high office building scaled for human occupancy and, on the other, a singular and monumental column made of black granite.

112

113



From 1556 until 1573 a pentagonal fortification in Caprarola, Italy, was transformed into a villa by Giacomo Barozzi da Vignola. He also reconstructed the main street through the village, so that the new Villa Farnese could be experienced at a variety of scales upon



approach, with a constantly changing juxtaposition of elements: At first a loggia over a modest entry door, then as a heavily rusticated base upon which an intermediate floor appears below the loggia, and finally as a massive pentagonal construction upon a generous terrace. On

mounting this terrace, one's eyes move upward through the villa's various floors as they shift in scale until the uppermost floors, where the diminished windows cause the bulk to appear to have swollen to enormous proportions.



### Multiple Scales

One might ask—what scale must a work be? A work can be of a more familiar and intimate scale or of a monumental, larger-than-life scale, one that impresses or awes. But regardless, the scale of a building is informed by the scale of the context in which it is located, by the scale of the context from which it is experienced, and finally the scale of operation that it serves. And these scales are often at odds with each other. A building, for example, exists at the scale of a city where it interacts with urban infrastructures of public thoroughfares, spaces, and vistas. It exists at the scale of the street as it interacts with adjacent buildings. It exists at the scale of the body, which allows an occupant to access it and interact with it both physically and spatially.

Scale is relative—and it is the various contexts from which buildings are experienced (and to which they are attached) that inform the various scales. As the cone of vision is reduced, as the building begins to lose its relationship to its broader context, new references are established, ones that more directly engage the body and the sensual. For example, when considered through the wide-angle lens of an urban skyline, like a Morandi bottle or a Cézanne apple, a building's responsibility is to interact with its "neighbors," the collection of buildings that constitutes the city. Here, exaggerated proportions and crisp profiles allow this relationship to become legible at the *scale of the city*. That very same building, however, approached from a lesser distance and at street level, might take on a much more defined scale—where proportions, color, material, and textures become important characteristics in defining its relationship to its immediate surroundings.



The independence of the primary steel structure from the exterior and interior wall panels of Pierre Chareau's 1931 *Maison de Verre* in Paris, France (with Bernard Bijvoet and Louis Dalbet), results in an open and continuous spatial experience. Here, walls are freed of structural

responsibility and this independence is reiterated at the scale of the sliding, folding, and rotating screens that choreograph a series of transforming interior experiences that allows for simultaneous, yet independent, programmatic and spatial interpretations.



Carlo Scarpa's 1958–64 renovation of Verona's Castelvecchio is conceived as an independent programmatic, material, and circulatory overlay onto the ancient medieval twelfth-century fortification. This concept of separate but connected systems informs the design of the building at multiple scales—from the floating

concrete floor slabs to the glazed enclosure walls sliding independently of the existing stone walls, to the bridges that extend the circulation between buildings. Here the architecture operates as intermediary device that bridges the intimate scale of the body and the enormity of the ancient fort structure.



The Gateway Arch in St. Louis, designed by the architect Eero Saarinen and structural engineer Hannskarl Bandel, transcends its status as a

structure that marks the site of the 1764 origin of the city and shifts to an imagined scale as gateway to an expansive western landscape.

### Interlocking scales

Like the nesting of Russian matryoshka dolls whose theme informs the painting of each successively scaled doll, an architectural concept informs the development of a building at multiple scales. In other words, a detail, a door, a room, a building is developed as variations of an overriding concept that informs the totality of a work.

### Quotidian versus Monumental

Buildings, cities, and landscapes are experienced at an everyday scale: the familiar of the daily and the prosaic. It is through making this scale unfamiliar, seemingly larger or smaller than the familiar in relationship to a specific context, that monumentality is achieved. But they can also have a larger-than-life scale—one that operates at the scale of the imagination. And while these "monuments" are often large in size, their power resides in their ability to convey meanings that transcend the quotidian.



Kurt Schwitters's 1923–37 Hannover Merzbau was constructed as an entire environment whose scale and content fluctuated almost daily. Constructed from scavenged detritus, it was simultaneously full-scale room and model of the world, one that housed an incrustation of talismanic traces and imaginary narratives. (Reconstruction by Peter Bissegger, Hanover, 1981–83)

# 13

## light

**Le Corbusier has said that "... light for me is the fundamental basis of architecture. I compose with light ..."** (von Moos, page 98).

Imagine if one were to begin with a box, a dark box—  
or a surface, a dark surface—how might light be intro-  
duced into that space or onto that surface? How might  
light *structure* a space or surface so as to bring order  
to it—bring it scale, bring it texture, bring it hierarchy?  
As light is incrementally introduced, objects and



The introduction of natural light at the perimeter of Eero Saarinen's 1955 Chapel at MIT in Cambridge, Massachusetts, accentuates the plasticity of its interior surfaces. The roughness of

the brick courses and geometries of the undulating walls are surfaces that are activated by the filtered light that is reflected off of the exterior moat that surrounds the chapel.



Light is given a spatial presence in this 1970 Sculpture Gallery by Philip Johnson in New Canaan, Connecticut, as it structures the surfaces onto which it is cast. Its traces not only help to define the dimensions of the works exhibited but transform the gallery itself into a work of art.

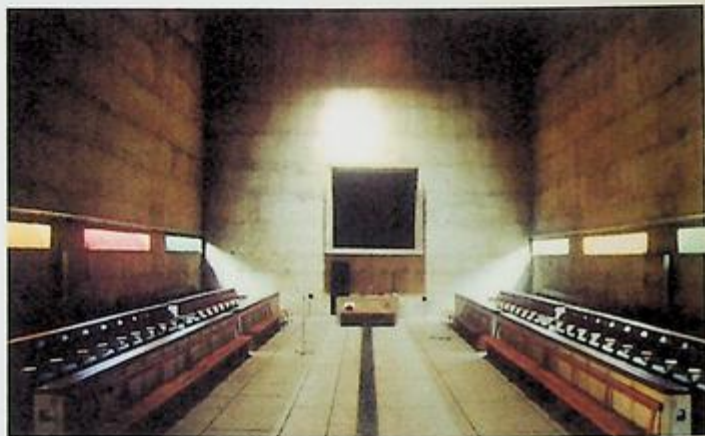

The church at Le Corbusier's Sainte-Marie de La Tourette monastery complex in Evieux, France (1956-59), is a large concrete volume whose apertures obscure the direct source of natural light. Not only are the church's rough concrete surfaces animated by kaleidoscopic patterns of

moving light, where one's gaze is continuously refocused to sequentially illuminated focal points, but the sanctuary itself transforms spatially as the surfaces alternately flatten and advance as the shadows come and go.

surfaces are articulated as they come in and out of focus and it is the dialogue of this light with the surfaces that it illuminates or passes through that produces an expanded spatial experience—a continuous transformation of form.

Yet, it is not the light, per se, that creates the space—it is the shadows that are cast that construct the space, for as Louis Kahn said, "All material in nature, the mountains and the streams and the air and we, are made of Light which has been spent, and this crumpled mass called material casts a shadow, and the shadow belongs to Light." (Lobell, p. xx) Thus, it is the manipulation of form through an understanding of the shadows that are cast that registers the generative presence of light.

### Spatial Transformation

Light is temporal and as it moves through a space it has the capacity to transform it. As surfaces come under the spotlight, they can alternately advance and recede from view, and the space through which light moves can expand and contract along its path. Materials can appear altered as their textures transform and volumes can seem distorted as their proportions appear to change.

### Textures

The surface onto which light is directed not only becomes hierarchically more significant than one that remains in relative darkness, but it amplifies its presence through the shadow that it casts. Textures can be revealed and exaggerated through exposure to light, just as they can be smoothed and made flat.

(continued on page 121)

# Steven Holl's Sculpting of Light

Steven Holl's architecture is one that deeply engages the senses, and it is through the interplay of light, color, shadow, and time that he choreographs an architectural experience. One could even say that his built forms are a result of the sculpting of light, and that it is this light that constructs the space of his architecture. His works are perceived as compositions of light that are literally experienced as one is drawn from space to space and further enriched as the gaze is guided toward the imagined spaces created by distant illuminations appearing within the surfaces that define the very same spaces through which one is moving.

In his Chapel of St. Ignatius, completed in 1997, it is the sculpting of light that not only produces the three-dimensional forms that emerge from the rectangular shell of the chapel, but it is the light that these forms in turn produce that renders tangible St. Ignatius' foundational guidebook and teachings: the necessity for moving between and making decisions amongst constantly shifting "lights and darkneses." Spatial complexity is subsequently produced within an uninterrupted interior volume through a series of spatial zones that are choreographed by these light-producing forms. As with Le Corbusier's light towers at Ronchamp and his light cannons over the priests' altars of La Tourette, Steven Holl's "bottles of light" continue the modernist tradition of *constructing* light as a primary generator of both architectural form and architectural space. And not unlike Morandi's still life paintings of the 1920s that construct a canvas of (exterior) spatial relationships, the collection of St. Ignatius's "Seven Bottles of Light" represent a canvas of volumes that have been carefully selected to devise an interior space of "gatherings of different lights." (Holl, Cobb, page 9)



Steven Holl: The Chapel of St. Ignatius,  
Seattle, Washington, 1997  
views of exterior and interior



Le Corbusier: Notre Dame du Haut,  
Ronchamp, France, 1954  
interior and exterior views of light towers

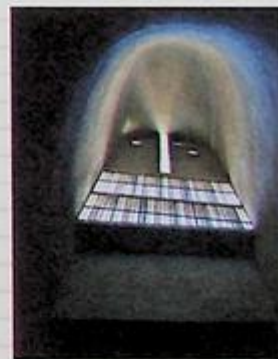

Giorgio Morandi: Still Life, 1952

Here, continuous yet spatially distinct three-dimensional spaces are constructed through the projection of these volumes of light onto surfaces that are as if permanently imprinted by the transmitted light, resulting in a series of abstracted interior canvasses. The necessity of fixed three-dimensional form gives way to continuously transforming spatial compositions that are defined by these intersections of surface and light.

In the expansion to the Nelson-Atkins Museum of Art, the introduction of light occurs at multiple scales. At the scale of the landscape, the enormous buildings of light that serve to illuminate the embedded galleries operate by day as sculptural pavilions around and between which leisure activity occurs, and by night as luminous lanterns that suggest imagined worlds lurking below the surface.

At the building scale, these volumes create Piranesian spaces of light and shadow that draw the visitor to the galleries below.

And, finally, at the infrastructural scale, the fusing of structure, air, environment, and light produces the optical instruments that can be precisely calibrated to experience the collection of art.

In Holl's architecture, light is the protagonist in the production of a relentless merging and blurring of architectural space. And it is in the construction of the softness of these volumes that one experiences the pleasure of his architecture—that one inhabits the glow.



Steven Holl: Nelson-Atkins Museum of Art, Kansas City, Missouri, completed 2007  
view of exterior light boxes

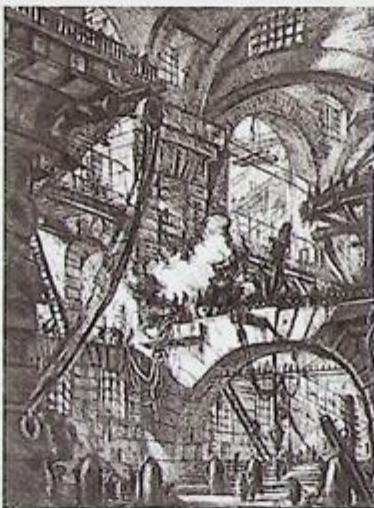

Giovanni Battista Piranesi: Untitled etching (called *The Smoking Fire*), plate VI from *The Imaginary Prisons (Le Carceri d'Invenzione)*, Rome, 1761 edition



Steven Holl: Nelson-Atkins Museum of Art, Kansas City, Missouri, view of interior



Steven Holl: Nelson-Atkins Museum of Art, Kansas City, Missouri, view of light structure



Light reinforces the spatial order of the Pompelan house. The atrium is the first room into which one arrives, above which is centered an aperture that admits both natural light and rainwater. Both

symbolically and physically, this central space of light was the heart of the household, around which guests and families would meet and water would be collected.



Tadao Ando's Church of the Light in Ibaraki, Japan (1989), is conceived as a concrete box that is subsequently incised to introduce natural light to its interior. Here, light has both a physical and spiritual

presence. The minimal dimensions of these apertures exaggerate the contrast between the sunlit exterior and the dark interior, while the profiles of the incisions simultaneously convey religious meaning.

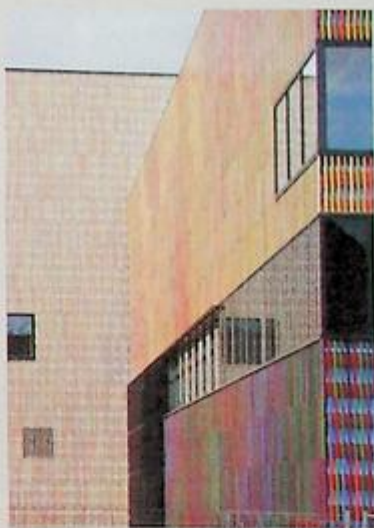

In Sauerbruch Hutton's 2002-09 Brandhorst Museum in Munich, the polychromatic facade connotes its program. It stands as a three-dimensional Pointillist painting whose independent layers of bicolored sheet metal and

multicolored ceramic rods combine to produce a continuously fluctuating facade that alternately intensifies and fades, and solidifies and dematerializes, as one experiences it from close and afar, frontally and obliquely.

### Chiaroscuro

Establishing contrast between light and dark serves to delineate spatial and programmatic boundaries. The crisp profile lines that render legible contrasting patterns of light and dark, control the effect of this duality. Extreme contrast can be achieved by the introduction of light through a controlled aperture where the profile of the cut is important in demarcating the amount of light that enters a space, allowing the imagination to complete that which is left in darkness.

### Distortion

Spatial experience can be intentionally transformed through choreographing the relationship between a light source and the surface onto which it falls. As darker spaces tend to recede and brighter spaces advance, three-dimensional depth can be exaggerated

within a fairly shallow space. Volumes can appear flatter or more three-dimensional and dimensions can appear increased or decreased. Spatial sequences are introduced as one is drawn from dark to light. Alternately, boundaries between spaces can be blurred as light becomes more uniformly distributed. This play of light cannot only produce simultaneous and shifting spatial readings—but it also challenges static programmatic relationships, where unique behavioral patterns emerge as occupants' gazes and movements seek shade and/or light.

### Color

In his *Theory of Colors*, Johann Wolfgang von Goethe writes "The eye sees no form, inasmuch as light, shade, and color together constitute that which to our vision distinguishes object from object, and the parts

of an object from each other." (Goethe, page xxxviii) And as all color perception is both relative to the eye of the observer and to the (often colored) context in which it is perceived, it follows that an understanding of color in architecture introduces a potent symbolic and dynamic dimension to architectural form and space.

### Symbolic

Colors have traditional meanings associated with them—meanings that shift, depending on the culture in which they are located. Red is a symbol of luck in Asian cultures and often the color worn by brides, yet in South Africa it can symbolize mourning. Colors are also thought to produce certain environments that can alter perception and behaviors.

The color of Luis Barragán's Casa Gilardi (1976) in Tacubaya, Mexico, not only recalls Mexican textiles and pottery, markets and sun-drenched street walls, but illuminates the interior spaces of an elongated site.

The dining-pool room at the rear of the house introduces an almost mystical source of light where color, through its palette, reflectivity, and intensity, creates the illusion of infinite spatial depth.



### Perceptual

Certain materials and colors reflect light, others absorb it—effects that can accentuate formal relationships. For example, spatial depth can be exaggerated within a shallow field by juxtaposing a lighter colored surface against a darker background. Or a white volume against a black background will appear larger than a black volume against a white background: The perception of scale is always a function of the interplay between forms. Color can compensate for light or darkness and provide solace or destination or it can animate an otherwise uniform surface.

### Instrument

Entire buildings can operate as instruments for light, and nowhere is this more evident than in the Pantheon in Rome. Its 27-foot (8 m) diameter oculus dramatically illuminates—spiritually, literally, and temporally—the vast space over which it presides, and as the Sun moves across the sky, its sculpted light is cast onto the dome's spherical surface. The building is an instrument that produces a visible measure of the passing of time.



Devices that capture or filter light can become a dominant, sometimes singular, characteristic of a project. Often, these optical devices motivate exaggerated forms that are capable of directing or modifying generic light for a specific interior condition.

The cinema and ballroom of the Café Aubette in Strasbourg, France, designed by Theo van Doesburg, Hans Arp, and Sophie Taeuber-Arp and opened in 1928, deploys color as a device that negates any sense of materiality while simultaneously blurring the boundaries between floor, walls, and ceilings. The diagonal compositions are inspired by van Doesburg's own paintings, an exploration in creating a corresponding three-dimensional colored "atmosphere."

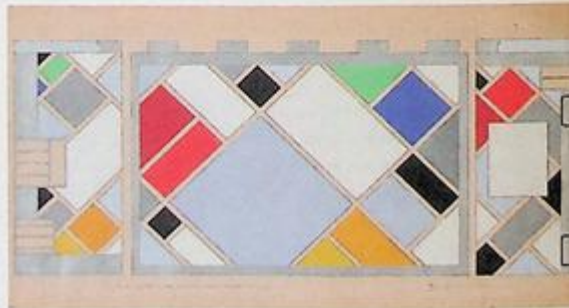

The façade of Jean Nouvel's Center for the Arab World in Paris, France, is an optical instrument constructed of thousands of individually calibrated lenses that respond to changing lighting conditions. This mechanical *brise soleil* (sun breaker) retracts and opens its lenses as the sun intensifies or fades, the resulting spatial (and aural, as the metal shingles click open or closed) effect being one of flickering shadows and changing landscapes.



Höweler + Yoon Architecture's 2004 installation in Athens, Greece, constructs a space of illumination and sound. As individuals move through a field of optic rods and floor speakers, emitted light and sound register their movements, producing a constantly transforming—and fleeting—spatial field.

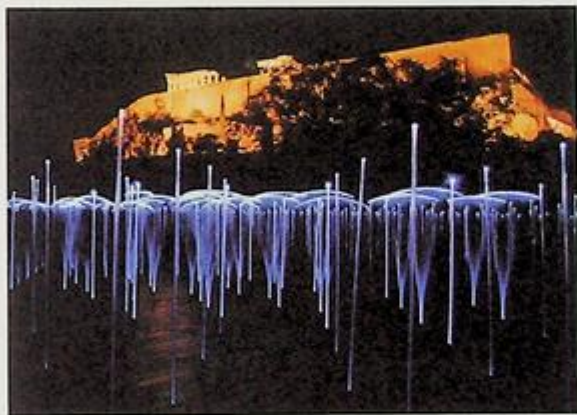

The painted corrugated-metal siding of the houses in Valparaíso serve to delay their inevitable rust in this Chilean seaport. Reputed to have come from the shipping

containers of passing freighters, these colored panels introduce a vibrant palette to this hillside community.

Louis Kahn's 1972 Kimbell Art Museum in Fort Worth, Texas, is an instrument for producing light. The parallel rows of the iconic concrete cycloid vaults that distinguish the building's form are a function of Kahn's desire to introduce indirect natural light to illuminate the gallery spaces. Skylights located between the extruded shells of concrete allow natural

light to enter and be reflected back upward to the underside of the smooth concrete vaults by aluminum reflectors that are attached beneath the skylights. The now indirect light is subsequently diffused downward along the curved surfaces of the concrete vaults into the gallery spaces below, where the artworks are displayed.

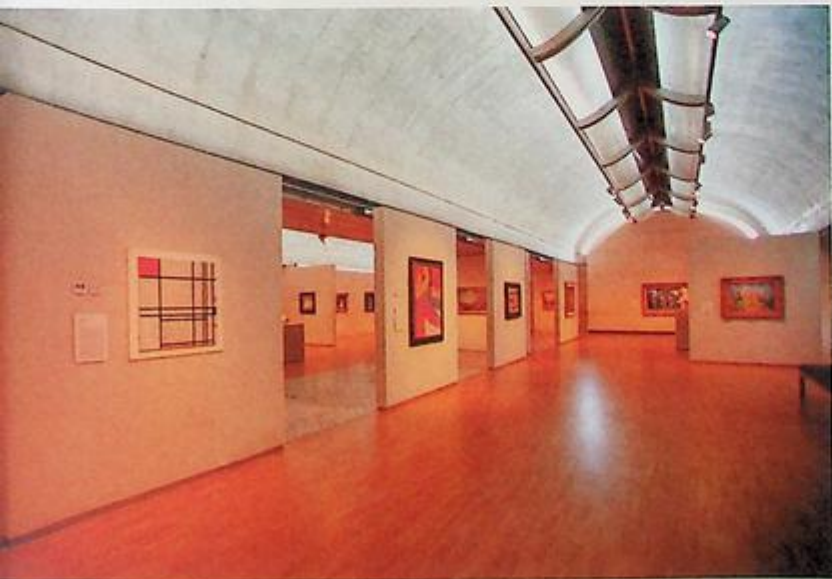

# 14

## movement

**Like a symphony, an extended sequence often has an identifiable theme that begins with a whisper and concludes with a bang, exploring along the way variations on the central theme.**

Movement through a building or a city is a way of organizing one's experience of it, of orienting the body in relationship to something outside of itself. And while architectural and urban form and space are typically static, it is one's movement through them that constructs a continuously changing environment.

Le Corbusier, in his 1929 Villa Savoye in Poissy, France, constructs a series of architectural compositions that subsequently choreographs the movement through the building and landscape. The relationship of volumes and surfaces in space and light creates a series of still lifes that the observer passes through as he/she navigates the building. A ramp carries the gaze diagonally through the building, from the entry vestibule up toward the raised courtyard and, finally, toward the sky.



As relationships between forms and spaces transform, and as one perceives these spaces and forms from multiple points of view, an otherwise monosyllabic and inert architecture is transformed into an endlessly complex and animate one. And it is the structuring of these relationships through a variety of movement systems that choreographs and defines that experience. A stair can collapse vertical relationships between spaces while a ramp might construct a more elongated unfolding of the architectural experience. Regardless, it is the introduction of space through time that produces a series of spatial and formal relationships, a fourth dimension to architecture.

### **Curating Space**

Choreographing the movement through space constructs formal relationships and reveals concepts. The order in which elements are experienced and the way in which they are framed become powerful lenses through which a work is given meaning.

### *Filmic*

Le Corbusier coined the term "promenade architectural" where architectural elements are not experienced from a single point of view but from multiple vantage points as one strolls through the architectural landscape. In this case, architecture can be thought of and experienced as a series of spatial stills or filmic frames that together constitutes a complete spatial experience.

### *Processional*

The reliving of a memory or the reenactment of an historical event can be embedded in the architectural works that mark that route. Like the Stations of the Cross that line cathedral walls and religious walks and are used especially during Passion ceremonies, architecture can thus preserve the fleeting event as a permanent memory. At a larger scale, there are, for example, several pilgrimage routes that traverse Spain and end in Santiago de Compostela, where the apostle St. James is entombed. El Camino de Santiago is marked with Romanesque churches with enormous portals designed to accommodate vast numbers of pilgrims and that, during much of the year, serve as a reminder of the now largely touristic but once ecclesiastical ritual.



Richard Meier's 1975 Athenaeum in New Harmony, Indiana, is essentially a viewing machine that uses its circulation to constantly reorient the visitor to its historic site: first to the modern town, then to its location next to the river, then to other nearby structures, and, finally, to the historic village of New Harmony. The sequence initiates from the edge of the

Wabash River, moves through the building's interior ramps and stairs, ending with a stepped ramp that gently deposits the visitor at the entry to the historic village. The central ramp further maps the formal and spatial structure of the building as it adjusts and resolves its shifting geometries so that it addresses the elements contained within its historical narrative.

#### *Narrative*

Architecture can tell a story—real or imagined—about an individual, a place, an event. The circulation can operate as an armature that collects and frames the visual icons that render the narrative legible.

#### *Theatrical*

Architecture has the ability to frame the relationship between its various occupants and, in so doing, either establish or reinforce various behaviors. Movement through space continually reframes the occupants' visions, constructing roles that shift from actor to audience.

In Lina Bo Bardi's SESC Pompéia São Paulo Recreation Center in São Paulo, Brazil (1977), a spatial web is constructed by a continuous circulatory scan as athletes pass between the changing-room tower and the sports facilities—as if actors on display for the audience below and yet afforded a privileged view of those who are, in fact, watching them.



## Sequence

The type of movement and the speed in which a work is revealed defines the architectural experience. A sequence can be highly choreographed and follow a specific (physical and spatial) itinerary or it can be intentionally random and allow for a multiple—virtually infinite—variety of encounters. It can be defined with a clearly articulated path (as with a bridge, stair, or ramp) or it can be constructed through formal and spatial relationships, where one moves toward a source of light or toward and between figural forms (as through a row of columns or between two volumes).

### Continuous

An uninterrupted sequence creates a fluid and continuous spatial experience with each space unfolding into the next. This sequence is often associated with ramps or generous staircases, where the speed of movement allows for an extended gaze that scans and collects the near and the far.

### Attenuated

Like a symphony, an extended sequence often has an identifiable theme that begins with a whisper and concludes with a bang, exploring along the way variations on the central theme. It often responds to contextual conditions—a narrowing of the space, an elevational difference—and occupancy—a trickle of wanderers versus a crowded stampede.

Circulation and gallery space are fused in Frank Lloyd Wright's 1959 Guggenheim Museum in New York City. Here, an enormous ramp defines the space of circulation, of art gallery, of interior court, and of building form. It allows for both near and distant views of the displayed works, with the movements of the visitors defining the space of the interior.



Tethered to the hillside by a light metal bridge, Mario Botta's 1971-75 single-family house in Riva San Vitale, Switzerland, collects both distant and near views of the landscape, beginning with the bridge and continuing as one descends the central staircase. Each level radiates from this spiraling stair, which in turn registers openings in the perimeter walls that reveal the forested landscape and lake beyond.

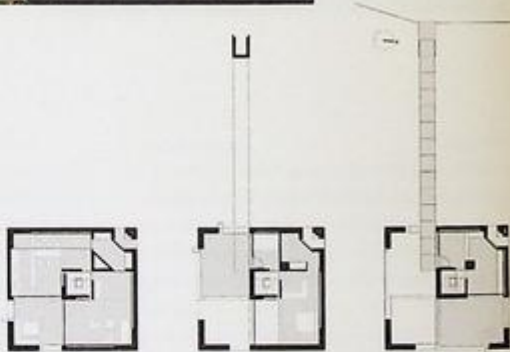

Adalberto Libera's 1938 Casa Malaparte in Capri, Italy, is an extension of the rock from which it appears to seamlessly grow. Its majestic staircase triumphantly extends the circuitous rocky ascent that is initiated in the sea far below it, culminating the sequence with the view of a distant horizon.





Each of the eighteen National Tourist Routes in Norway has a unique constellation of service buildings and access infrastructures (bridges, paths, parking) that reference a

route's own particular history and character. These fragments are discovered at unique moments along each route—constructed traces that render each route visible.

For example, along the Senja Route, Code Arkitektur's Tungeneset rest stop (2006-07) extends the island's perimeter road, gesturing downward to the sea.



Throughout the archeological park at Gilon Guyer's Museum and Park Kalkriese in Osnabruck, Germany (1999-2002), a network of symbolic paths represents various layers of occupation,



from the Roman Legion's route along the ramparts, to the Teuton's positions as they advanced and retreated, to a nonmilitaristic neutral layer of park trails. Three pavilions—Seeing, Hearing,

and Questioning—are distributed throughout the park, points in a landscape between which multiple encounters and trajectories can occur.

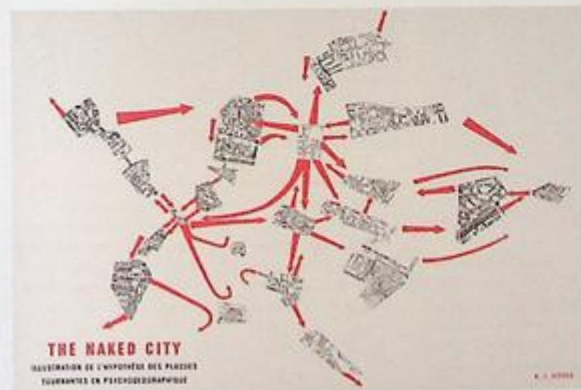

Guy Debord's psychogeography (1955) develops the idea that a thoughtful understanding of the city is developed by an aimless wandering, one driven by impulse rather than order, where one can construct a series of narratives that is unique to each itinerary.

### Interrupted

The experience of a building or a landscape need not be continuous—in other words, fragments of primary spatial experiences can be collected and reconstituted in one's memory as a comprehensive, if not continuous, experience.

### Random

Here, the accidental encounter is privileged over the controlled, where the movement through a building or landscape is intentionally unstructured. This creates an experience that allows for a continuous recombination of architectural experiences, with each combination producing a unique reading of the work.

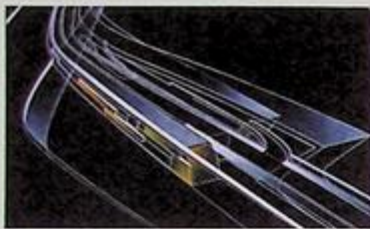

The building volumes of Zaha Hadid's 1996-99 Landscape Formation-One in Weil am Rhein, Germany, are an extension and transformation of the park's existing

networks of meandering circulation paths, creating a three-dimensional spatial weave and obscuring the distinctions between architecture and landscape.



### Dialogue

Movement through space is often a distinct system that establishes a dialogue with a particular context. It can either amplify and, in so doing, render legible an existing infrastructural network or it can overlay a distinct spatial, material, and temporal dimension. The dimension, geometry, and material of movement systems often demonstrate their occupants' requirements, from turning radii (automobiles), to angles of incline (accessibility), to minimum widths (egress safety).

### Amplification

Movement systems can originate within the context in which the work is situated. They can attach themselves to existing circulation networks, amplifying their presence into three-dimensional form, thereby blurring the boundaries between exterior and interior, landscape and architecture.

### Interface

Systems of movement can operate as material and spatial mediators between distinct conditions: between past and present, between two scales, between two programs, between two materials, between two speeds. Often, they introduce the human being into a liminal space between two conditions, establishing a critical dialogue that allows one to be understood from the lens of the other.



Studio Labics and Nemesi Architetti Associati (1999-2004) overlaid a system of steel bridges, ramps, and thresholds onto the archeological ruins of Trajan's Market in Rome.

Italy. The distinct material and dimensional layer introduces an independent circulation system that allows the visitor to navigate the traces and remains of the vast 113 CE brick structures.



Multiple movement systems define the architecture of Centre Georges Pompidou, designed by Richard Rogers and Renzo Piano and completed in 1977 in Paris, France. Be it the movement of air, water, electricity, art, or people, each system is given a clear expression that defines the form of the building. The city of Paris is displayed as a picturesque canvas as one moves up the exuberant, and now iconic, escalators that traverse the exterior of the building.

#### *Multiple/Parallel*

Simultaneous or parallel sequences reveal alternate architectural experiences: The short and sweet is distinct from the long and leisurely, the honorific from the prosaic, the once a year from the every day. The enormous central brass doors to the Vatican's St. Peter's open on special occasions, allowing for an axial procession up the stairs and into the central nave, versus the everyday perimeter doors that provide access to the local and the touristic. Courthouses also have multiple sequences—one for the accused, one for the public, and a third for the judiciary—each demonstrating various scales of access and security that reflect the special circumstances of each group.

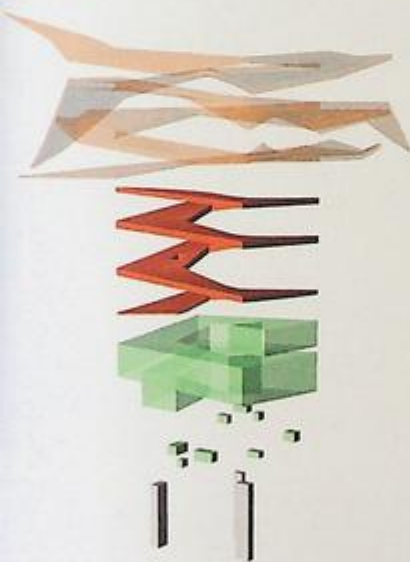

The form of the 2008 Automobile Museum in Nanjing, China, by 3Gatti Architecture Studio is a function of the building's independent, yet intertwined, circulation trajectories. The building's paper-thin concrete floor wafers are

formed and deformed as a function of the automobile's external upward spiral, transforming the car from prosaic machine to exhibited object as it navigates the ramped surfaces. The pedestrian's inner descent ramps back down through

each layer, introducing yet another dimension and operation to the folded plates as the inner surfaces adjust to the human scale. An elevator adds a third means of navigating the structure—a direct route back to the top layer of parking.

# 15

## dialogue

**A work is constantly renewed by its encounters with new perceptions, new works.**

Most works of art—including, of course, architecture—are evaluated by their capacity to “live” beyond their boundaries. That is, a work is seen to have an enduring artistic value when it repeatedly transcends its superficial subject matter, and to engage others in an ongoing exchange of observations, understandings, and even

The Vietnam Veterans Memorial wall in Washington, DC (designed by Maya Lin, completed in 1982) is a complexly dialogical construction that has evoked countless, occasionally contradictory interpretations: a wound in the ground, a ditch, a bulwark, a "V" (Vietnam or victory?).

a transitory bolt of lightning, a timeline, an arrow, a mute tombstonelike symbol of death, a vibrant mirrorlike reflection of life. Here, the construction of memory—and meaning—is wholly the task of the individual visitor. However, concern over the unpredictability of interpretation led politicians to

supplement the wall with a realistic sculpture representing three male soldiers and, later, another depicting three female nurses and an injured soldier, explicit representations intended to delimit the range of possible commemoration.



Rafael Moneo's El Greco Congress Center (2012) establishes a clever dialogue with the fortified walls of historic Toledo, Spain, but incorporates the traditional rubble construction within bands of concrete, and the

irregular system of "buttresses" that resonates with other externally-supported ramparts that were reinforced by necessity over time, are in reality, hollow ventilation shafts serving the subterranean parking garage.



Ragnar Östberg's Stockholm Town Hall (1923) is a festival of dialogues, from the historic to the internal. Its Riddarfjärden façade is composed of bands of windows that seem to follow their own rhythms, reminiscent of the Doge's Palace in Venice, an allusion to Stockholm's maritime

affinities. Additionally, details such as the occasionally aberrant column—only one in the loggia being octagonal for instance—signal their varying roles within the circulatory paths of the building. With its blind "windows," apparently erratic apertures, subtle brick hieroglyphs

(like the crescent moon to the right of the large window), and intentional misalignments, Stockholm's Town Hall keeps the viewer's eyes dancing and mind speculating on its countless layers of meaning and elusive systems of order.

behaviors that can persist long after the work is complete, even after the author and the original audience are no longer present. Such works initiate an open-ended, *dialogical* engagement with their world. Indeed, much of a work's meaning and identity is developed by an audience's past and present experiences as elicited by the work, and of their perceptions of the work's relationship to other works. A work is constantly renewed by its encounters with new perceptions, new works.

A *monological* work, on the other hand, has no intention of engaging its audience in a new or transformed understanding of their

worlds. This work insists on the unambiguous singularity of its meaning and resists—occasionally fears—multiple interpretations. It is the unequivocal voice of authority. Monuments will often adopt a monological tone, lest the subject of their commemoration be subject to unanticipated interpretations. Also, buildings considered to be primarily utilitarian might operate monologically (factories, water towers, electrical substations, and grain silos), but this does not preclude them from being overlaid with imposed interpretations, or for these functions to be accommodated in a design that has more expansive aspirations.

Architecture also approaches the status of a monologue when it is designed with a singularity of intention (perhaps a work intended as a manifesto) or one in which the designer is determined to make an autobiographical or otherwise private statement, with the identity of the author being the predominant message. Works of limited capacity for dialogue include those that simply mimic another work—like someone who annoyingly repeats another's words—or those that merely negate without rebuttal, a "no" without any positive assertion.



Left: In converting the ruined Santa Maria do Bouro Convent in Amares, Portugal, into a hotel (1987–97), Eduardo Souto de Moura uses contemporary materials to articulate the modern occupation of the structure while scrutinizing its former status both as a once grand convent and—perhaps more compellingly—as a ruin. Highly reflective, frameless windows simulate the empty apertures of a ruin, pretending to reveal sky within. A weathering steel panel traces the window's proportions while displacing it in space, underscoring the massiveness of the wall with



the thinness of the steel. Fragments of now irrelevant masonry protrude along the clean, scarred wall, joined by rust stains leaching from the newly inserted balcony.

Above: The minimally punctured wall of a wing of the former convent's cells serves as both a background and a primary rhythm and the syncopated rhythms of the new, highly fenestrated wing of hotel rooms in this part of

Fernando Távora's Pousada Santa Marinha in Guimarães, Portugal (1984). Viewed from above, this new wing appears to be a simple terrace; it is both literally and figuratively a new ground for the convent.

The architectural designer has numerous resources for the production of a work that engenders dialogue: program, site, various forms of representation, other buildings (adjacent as well as unseen or even unbuilt), materials, forms (basic and compound), personal experiences, memories, and the participation of a cadre of others. The role of these others—instructors, critics, collaborators, clients, users, historians, and casual observers—is essential to the continuation of a work's capacity for dialogue, not just through active critique, but also by placing a work in the context of other works and

experiences, and by seeing architecture's capacity for shading the memories of past experiences and establishing a framework for future observations.

Inevitably, architectural forms invite a certain amount of discourse. No architect can be fully aware of the meanings that have accumulated in even the simplest of forms, forms saturated by centuries of history and the countless recollections, world views, and experiences of individual observers. For this reason, most forms—from spheres and cubes to petal-shaped roofs and insectlike substructures—

are dialogically open ended; they have no determinate past and can have no fixed future. The role of the architect is to facilitate the discursive aspect of forms, and by engaging various types of dialogue, to allow the continuous redefinition of a work's meanings by all of its observers and all of its contexts.

In the more dialogical works of architecture, everyone has an opportunity to "construct" the work, to assign it values and meanings, both internally and in relation to its environment. It is through dialogue that everyone becomes an architect.

The façade of Francesco Borromini's Oratory of the Filippini on the left (completed 1650) both translates and analyzes its neighbor, the Chiesa Nuova (façade by Fausto Rughesi, c. 1605); to gaze at one is to interpret the other. The Oratory's segmented gable refers to the subtle layering of that on the church; the small arch of the church's upper window becomes a flattened half dome in the Oratory; the shallow arch framing the church's central doorway sponsors a shallow

bulge at the Oratory; the belt across the Oratory's middle aligns with the church's lower cornice and frieze; the capitals of Borromini's pilasters are reductive versions of those at the church; and while the church steps forward at its center, the Oratory's façade presents an emphatic concavity. The main entry to the new complex is through the small door in the gap between the façades, duplicating the dimensions of the church's side doors.





Giuseppe Jappelli's Caffè Pedrocchi (1831-42) in the historic center of Padua, Italy, is triangular in plan and uses the same motif to establish multiple dialogues in varying contexts. The

porch motif with its largely blank background story with a single door and embedded frieze sits alone in one piazza, establishing a center to the space while appearing to be a pavilion embedded in the



fabric (although the "gothic" structure to its left is actually a later addition by the same architect, engaging his own building in a complex, time-bending dialogue). A street façade in which two

of these motifs are used as bookends terminates in another piazza in which two of these porch/pavilion motifs are subordinated to framing a large central bay, sheltering an outdoor café.



Within a former cloister near the entry of the Santa Maria da Conceição Convent in Guimarães, Portugal, now a pousada, Távora reveals the building's promiscuous history of repeated reconstructions

by excavating a carefully delineated "window" into the wall, making the viewer part of the building's complex past while establishing the case for its current transformation into a hotel (completed 1984).

## Forms of Dialogue

One of the most effective techniques of interpreting forms is to measure them against other forms, not just through similarities but also through differences.

### Contrast

The dialogue between two contrasting forms is especially powerful, in that contrast provides a relational means of defining a form. To perceive something as being small, it is necessary to perceive it in relationship to something else that is big. Heaviness is understood in its relation to lightness, roughness to smoothness, oldness to newness. Without a sense of one of these terms, the value of the other remains undefined. Moreover, each term carries within it a remnant of its opposite: The concept of "natural" always retains traces of "artificial." In each case, further dialogue can lead to a reorganization of these terms, with something heavy, for example, suddenly understood as being weightless.

A work can also develop through a series of internal dialogues: unique versus repetitive elements, curvilinear as opposed to

orthogonal forms, figural components within background field conditions. It is also possible for an element to develop evolving understandings when understood in dialogue with an environmental or temporal phenomenon. For example, a form can be understood alternately as opaque, translucent, or transparent, based on the time of day, changes in location of the Sun, the engagement of screens, or the transitions between external daylight and internal artificial light.

### Enrichment

The *enrichment* of meanings can also arise from a dialogic engagement. For example, a design can *elaborate* on the meanings of an existing building or site by highlighting—by framing, isolating, or uncovering—previously underemphasized or hidden aspects of the previous forms.

Dialogue can arise from the *reiteration* of forms, supplementing meaning by resituating or reframing other forms in differing contexts. A form—just as a phrase—transplanted into a different context absorbs new inferences, new potential meanings, that reflect back onto the original.

### Redirection

*Redirection* can also be a means of engaging a work or form in a dialogue. This can occur by means of reprogramming, as in the case of a doorway becoming a window, a factory becoming a museum, or a garden becoming a roof. It is possible to directly *supplement* the meanings of a form by adding or subtracting details or characteristics. Examples of *subtraction* include cutting into buildings in order to reveal aspects that might have been previously unconsidered, to open views previously inaccessible, or to introduce new sequences that retell a building's narrative.

### Addition

*Addition* may produce an expanded or unexpected interior within the implied volumes of an exterior, bring new emphasis to one component in a series, or suggest further meanings by presenting a form or motif in an alternative material (what was brick becomes stone) or shape (one in a row of round columns is hexagonal instead).



As much because of his unique style as because of his brilliant application of complex forms, Jozef Plečnik's interventions in the Castle of Prague suggest an indefinite chronology while suggesting possible systems of symbolism. His "Gate to the Garden of Paradise" (1925)

suggests a portal composed of a thin roof draped over two logs supported by four bulls, but it is, in effect, a covered stairway descending to the garden from a courtyard, revealing a large gap to a green space opened beneath the heavy walls of one wing of the castle.



As the façade of Michelangelo's Palazzo dei Conservatori at the Campidoglio in Rome wraps the corner of the building, its elements incrementally merge with the medieval fabric of the earlier building. Whether this resolution was originally intended or not,

the result is a clever formal conversation that challenges the viewer to interpret the surface and its components—pilasters, railings, frames, brackets, apertures—in contrasting sets of implications, depending on whether one reads from the left or from the right.

a population's shared memory. Many public buildings (especially courthouses throughout the United States) have made reference to the Parthenon when they attempted to appeal to a sense of monumental importance. Similarly, a work might recall a local building technique or typical materials and utilize these resemblances to develop a design that establishes a dialogue with a vernacular.

### Scales of Dialogue

Architectural dialogues can occur at multiple scales: at the level of the city, of the building, or of the detail. It is even possible for a dialogical relation to cross over scales: for a building to engage a city, or for a detail to consider the entirety of a building in microcosm.

### The City

Urbanistically, a design can engage an aspect associated with its city—a canal or a boulevard—presenting it in a unique way. A building can reiterate the massing or silhouettes of other structures in its vicinity while introducing a new pattern of usage. Or a building can open unseen vistas into some of the unobserved crevices of its urban fabric, suggesting through a dialogical engagement those conditions and traits that introduce new perceptions of a city that had once been known in a very different way.

### The Building

A design can engage another existing building in a new dialogue, superimposing new modes of understanding on a once familiar structure or condition. Such engagement can reinforce another building's role within a community. It could also subvert previous understandings of a building to suggest new values and significances.

### The Detail

Or a design can address specific details of its precedents: a roof shape, a traditional system of joinery, an entry condition. Dialogical engagement of details can focus attention on aspects of craftsmanship, can reinvigorate forms that have become overly familiar, can overwrite previous implications, or can even infer new or forgotten social or cultural interpretations.



In transforming the Monastery of the Lima Refólios into the Agrarian Graduate School of Ponte de Lima, Portugal (1987-1993), Fernando Távora clearly indicates his newer intervention, but with no attempt to simply restore or

remodel. A sunken door beneath an asymmetric window is reorganized into a balanced composition with the forceful interruption of the new window. More than a door and window, the result is a trio of diverse voices.

### Indexing

Some facets of dialogue are derived from the concept of *indexing*, whereby there is an indirect, relational aspect between a form and the perception of its meanings, often one that has been learned from experience.

Just as smoke seen rising from a chimney is an index of a fire inside, certain forms have had either a general (to a population) or specific (to an individual) relation to meanings. For example, the typical image of a house form—a rectangular box with a gabled roof, a single door, and possibly a chimney—is a standard index of "home," despite being as historically associated with classic Greek temple forms and traditional barn structures as with any actual residences. In the world, very few individuals actually lived in buildings that looked like this "house." Nevertheless, works that incorporate such a form may resonate with some viewers as having a cozy, familiar, domestic impression, despite being perhaps institutional or commercial structures

A work can also index other works, usually historical, that may or may not be an aspect of

# 16

## tropes

**A trope may be employed in order to instigate fresh understandings of something that has become conventional.**

Conceptions founded on rhetorical figures—especially the tropes of metaphor, metonymy (and synecdoche), hyperbole, irony, and personification—have been instrumental in the design and reception of countless artistic, scientific, and even cultural constructions. Ubiquitous in every branch of the arts and sciences (one thinks of



Commercial architecture often indulges in overt metonymy, with restaurants shaped like chickens or flanked by lumberjacks, and corporate headquarters configured as their products. The famous Brown Derby restaurants in Los Angeles (the first was constructed in 1926) were extremely

successful, due largely to their conspicuousness and the mock monumentality of their gigantic derby hat cum dome. The hat suggested associations with Western heroes and outlaws, as well as famous Hollywood characters such as Charlie Chaplin's Tramp.



Eero Saarinen's TWA Flight Center at John F. Kennedy Airport in New York City (1962) sought a formal vocabulary that could represent "the spirit of flight," as well as embody a fluid efficiency from arrival

to ticketing to boarding. One of the most exhilarating and iconic airport designs ever produced, its layered metaphors conjure an elegant raptor just before flight, and a weightless sense of soaring.

the atom as a miniature solar system, or the "flow" of electric "currents"). tropes are frequently assimilated so completely they often go unnoticed. Buildings, for instance, are described as "sitting" by the road, "facing" the park (both personifications), "cascading" down a hill (metaphor), or "the White House announced ..." (metonymy).

At first, a trope is evasive—the actual subject is temporarily absent, replaced by something else—creating a diversion that initially *defamiliarizes* the original subject, distancing it from the observer. But upon realizing a connectedness to the original subject, tropes ultimately prove to be devices for *familiarization*. Architecture, for instance, usually constrained by its own internal language of forms, is made familiar by its association with more universally recognized forms or ideas.

Tropes build connections between many aspects of our world, proposing a relativity between the knowable and yet-to-be-known phenomena we observe.

### Types

There are many types of tropes, with many classes and subclasses. But certain tropes have appeared with greater frequency throughout architectural history and continue to have a value in the design of buildings and the education of architects.

#### Metaphors

In a *metaphor*, something that is potentially unfamiliar or less known is elaborated by a reference to something that is known—a similarity is established. This usually involves removing one component from its literal meaning so that it can stand for something else. When, for example, Jimi Hendrix sang (in 1967), "And so castles made of sand fall in the sea, eventually," he was not discussing castles, sand, or seas but, instead, aspirations, time, and fate.

Aristotle argued that metaphors were the greatest tools of the poet, and that they instigate learning in their audiences. Kenneth Burke saw the analogical extensions we develop through interpreting metaphors as essential in shaping our perspectives of the world.



The oversized vitrine of Bordeaux Law Courts (France, completed 1998), by the London-based Richard Rogers Partnership, not only argues metaphorically that the transparency and accessibility of a courthouse

is analogous to the same characteristics in the law, but the building's seven wooden caselike courtrooms metonymically refer to Bordeaux's preeminence as a wine region.



The use of tropes was especially pervasive in the architecture of eighteenth-century France, when a reaction to the exuberance of the late baroque led to a reductive classicism and an attempt to make architecture

"speak" directly to its audience (*architecture parlante*). Étienne-Louis Boullée's metonymic design for a Cenotaph for a Warrior (c. 1780) proposes the monument as a colossal sarcophagus.



The summer house that François Racine de Monville designed for his estate at the Désert de Retz near Marly, France (1774), is an example of a synecdochic architecture.

The entire house is built as a fragment of a colossal column, implying the imaginary presence of a gigantic temple that has since collapsed in ruin.

Words and images accumulate metaphorical values through time, occasionally displacing their objective identities—think of "storm," "willow," "snake"—evoking instead emotional, behavioral, mythological, and even ethical associations. In the same way, after thousands of years, most architectural forms have been overcome by metaphor: hearth (heart of the home, warmth of family), thickened wall (protection, security), gabled roof (shelter, homestead), lighthouse (forewarning, guidance), gateway (initiation, transition).

Because, as with most poetic language, metaphors usually exceed their boundaries, their analogous relationships can bring new insights to otherwise insufficiently observed phenomena. At the same time, because they are susceptible to layers of interpretation, often based on individual experiences, metaphors can occasionally spin out of control. (For example, Romeo's "Juliet is the Sun" hardly means that she is yellow or round, although to some of today's audience, it could mean that she is "hot.")

#### Metonymy

With *metonymy*, there is contiguity between the original and its substitution, which is often an associated icon. The classic example is, "The pen is mightier than the sword," where "pen" stands in for writing and "sword" for combat. Related to metonymy is the *synecdoche*, in which a whole is replaced by one of its parts, or a part is replaced by a whole. Most movie criminals seem to be named synecdochically, as in Louie "the Ear" or Bertie "the Chin."

If there is an intrinsic romantic poeticism to metaphor, metonymy is basically realistic. While the series of possible analogs accompanying a metaphor often extends beyond the initial presentation, in metonymy there is a focus on a singular condition, with an abridged, delimited perception. In synecdoche, this abridgement can even lead to a sense of surrealism, as with Nikolai Gogol's "The Nose," in which a minor official's nose surpasses its owner's social prominence. Architecturally, metonymy can be employed as a type of shorthand, providing immediate recognition of a structure's function or character.



Jean-Jacques Lequeu's project for a *Rendezvous at Bellevue* (1777-1814) represents the other aspect of *synecdoche*, in which the parts are composed of wholes. Here, a Greek temple becomes the lantern of a Renaissance tower that is, in turn, attached by an Islamic

arcade to a Palladian pavilion in the attic of a composite villa, and so on. The project—a *rendezvous of forms*—is an argument for the idealization of episodic architectural events and the potential harmony of eclecticism.

*Irony*

While there are many forms of *irony*, they all share the characteristic that what is presented has some opposition to what is intended. Jonathan Swift's famous essay, "A Modest Proposal," in which the author seems to advocate the eating of children as a solution to rural poverty, is considered to be a masterpiece of ironic writing.

*Irony* is one of the more difficult tropes. An audience unaware of the ironic intent (usually indicated by a larger context or a subtle "wink") may understand an assertion at its face value. *Irony* constantly fluctuates between seriousness and jest, between positive and negative poles. While Swift was not advocating cannibalism, for example, a simple understanding of the opposite—that cannibalism is bad—would also miss his point.

In architecture, ironies are most effective in challenging beliefs that may be entrenched, or in overturning formal complexes that have been overcome by facile interpretations. For this reason, one finds that many memorials, especially those that remind us of painful historic events—such as acts of genocide—employ ironic formal devices: Determined to be noticed, they invert traditional monumental forms such as obelisks and stelae or tease with an act of disappearance (as in the Monument to the Deportées, chapter 20).

*Hyperbole*

*Hyperbole* is an obvious exaggeration, intended to emphasize a specific characteristic or condition, as in "waited an eternity."

The architectural hyperbole is often incorporated when the designer wishes to introduce a new form-type (a cone in place of a dome), to emphasize the uniqueness of a feature (bulbous protrusions on a rectangular block), or to underscore a characteristic (as with exaggerated classical motifs on a design grasping at monumentality).

One occasionally finds hyperbole's opposite, *understatement*, incorporated in architecture that attempts to recede into an urban texture, where conspicuousness may be considered a liability—as with certain clandestine clubs or utility buildings, for instance.

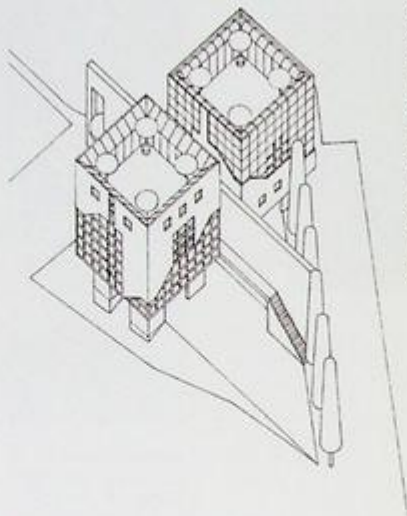

Oswald Matthias Ungers used Shakespeare's retelling of Ovid's "Pyramus and Thisbe" myth as the central theme for a house in West Berlin (c. 1976), not far from the Berlin Wall, on a site once containing a medieval wall. The story tells of two lovers from neighboring estates, forbidden to meet by their feuding families. Their only communications occur through a crack in the wall.

As in Shakespeare's version, the wall is also a character in Ungers' design, with the house bisected into a work cube and a residential cube, connected only through a single aperture in the thick wall. More than a house built on personification, Ungers' Pyramus and Thisbe develops a metaphor and eventual commemoration for the divided Berlin.

The *Barrière du Trône* (1787), comprising two identical pavilions and two giant columns, is one of Claude Nicolas Ledoux's tollhouses at the gates to Paris. The pavilions combine a hyperbolic monumentality—a massive façade containing a grandiose arch with

exaggerated *voussoirs* surmounted by a pediment shouldered by inflated brackets—leading to a remarkable understatement—an unassuming doorway. *Hyperbole* denotes the structure's civic pomp while understatement connotes the civic functionaries within.

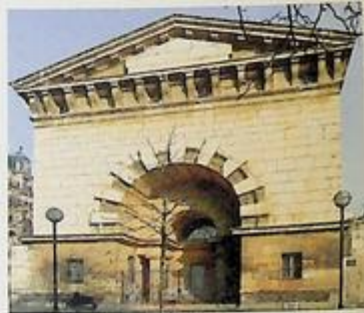

Frank Gehry's Nationale-Nederlanden building in Prague (1996) is known as "the Dancing House." Its forms originated in part as a personification of the famous dancing duo of Fred Astaire (the portion with the more vertical department) and Ginger Rogers (the more dynamic). The dancing metaphor is especially appropriate, given the building's proximity to neighboring baroque structures, extending their regularity with its fanciful distortions.

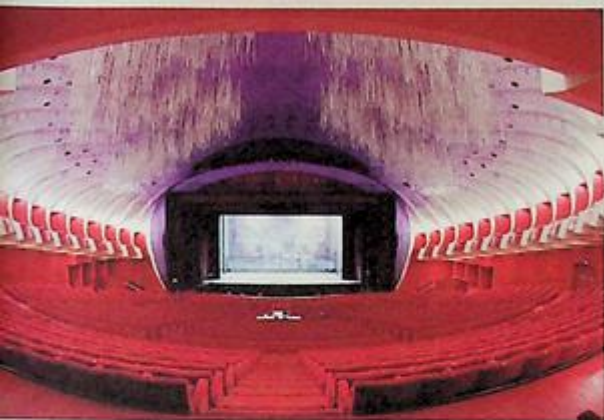

Carlo Mollino's Teatro Regio in Torino, Italy (completed in 1973) incorporates a subtle form of personification with its plan assuming the

contours of a female torso, a figure the architect held in the highest esthetic regard. The auditorium volume itself is a deep reddish-violet, a

reference to womb and royalty, with the stage's proscenium intended to suggest the shape of a television screen.

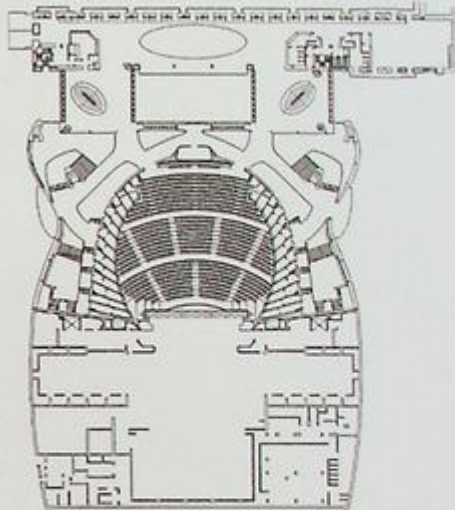

### Personification

With *personification*, animals, natural phenomena, abstract concepts, and inanimate objects are given human traits. Personification is very common in fables, fairy tales, and mythologies.

Personification can also have a double reading, in that while a fox might be presented as a man, there is the implication that men can be foxlike. Personification can be a technique for representing architecture's abstract characteristics in a way that can be understood on a "human" level, as with Lequeu's attempts to apply physiognomy to façade design. It has also been quite prevalent in architecture that addresses the human body as a source for the organization of space.

### Values and Perceptions

In the design process, there can be both *operative* and *expressive* tropes. An *operative* trope is used primarily for motivating the design process and is usually "buried" as the

process progresses, often overcome by additional design concerns or by other conceptual investigations. To some extent, every diagram is an operative trope.

An *expressive* trope is central to the design's concept and, when understood by the observers of a work, provides them with tools for expansive interpretations. A trope may instigate a range of fresh understandings for something that has become conventional. An architect might also use an expressive trope to introduce an audience to an unfamiliar or ineffable program that has no established formal language.

There is, however, an inherent danger with tropes, for both the designer and the observer: one can become lost in the endless analogs of the metaphor, the fragmentation of metonymy can permanently obscure the whole, or one might become content with the absence of the actual subject.



Jose Plecnik wanted his Church of the Sacred Heart in Prague (1932) to incorporate a brick pattern that suggests the texture of an "ermine cloak." The metonymy here is a reference to the traditional cloak of royalty and a central

symbol in Christianity, incorporating the nobility of Christ and, because the ermine's coat becomes darkened in the summer to lighten again in the winter, a reference to resurrection.

The goal of defamiliarization is to prompt others to actually *perceive* for the first time something that has perhaps already been seen on countless occasions—to grasp the extraordinary in something that has, until now, been routine.



# defamiliarization

**By introducing unfamiliar sources of conjecture as well as unfamiliar techniques of observing, of conceptualizing what is observed, and of describing what has been conceptualized, the architect is able to cultivate a set of enhanced sensibilities.**

Just as a building is expected to provide shelter, facilitate our day-to-day activities, and give us a sense of comfort and familiarity, architecture may also on occasion lead us to question what we believe about the world, to contemplate what has become customary or habitual, to reevaluate what makes us comfortable, to

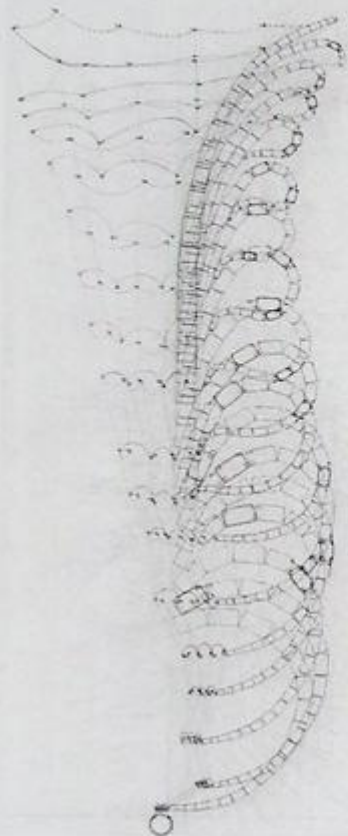

This pencil drawing by a first-year student illustrates an interpretation of the defensive movements of a vampire squid. While not an anatomical representation, the record of these movements is already anticipating the construction

of an animated model that may later be used to propose a structure capable of turning itself inside out.

Student: Allison Wills  
(faculty: Val Warke & Jim Williamson, teaching associate: Larisa Ovalles)



From its exterior, the Mãe D'Água Amoreiras Reservoir in Lisbon (constructed 1834 from designs by Carlos Mardele), seems to be an elegant urban monument, perhaps even a temple. The roof is a public plaza, providing vistas of the city. Inside, however, the structure is full of water, being the termination of an eighteenth-century aqueduct, once the

city's primary source of fresh water. Occupation of the interior had been limited to the perimeter, with a grotto-like cascade announcing the water's grand entrance into the city. The Mãe D'Água Reservoir diverts notions of building and landscape, inside and outside, rustic and urbane, even floor and wall from the realm of the expected.

challenge what we think we know. Similarly, in the education of an architect, evoking the unfamiliar is an essential technique for motivating the creative process and going beyond mere reiteration. By introducing unfamiliar sources of conjecture as well as unfamiliar techniques of observing, of conceptualizing what is observed, and of describing what has been conceptualized, the architect is able to cultivate a set of enhanced sensibilities. An architecture that results from this process can provide the observer with an exceptional way of comprehending the world, and consequently an expansive, intensified way of living in the world.

"Defamiliarization" was first evoked by the literary theorist Viktor Shklovsky in "Art as

Device," published in 1917. He saw defamiliarization (his term was *ostranenie*) as a technique, central to many of the arts, whereby the reader or observer is given a more indirect perceptual route than in everyday presentations. The goal is to prolong the act of perception in a poetic work, to make it less automatic and more thoughtful.

While we may feel close to the familiar, such closeness may obscure the genuine object. Defamiliarization distances the object from its observer, opening a space of cognition that requires thoughtful navigation. But there is more than poetry in this gap. If there is a comfortable stability to what is familiar, defamiliarization ultimately discloses the instability lurking within—the variability of observations across times and cultures and from individual to individual—as well as exposing the opaque veil that "familiarity" often constructs around a subject, preventing one from seeing its deeper significance.

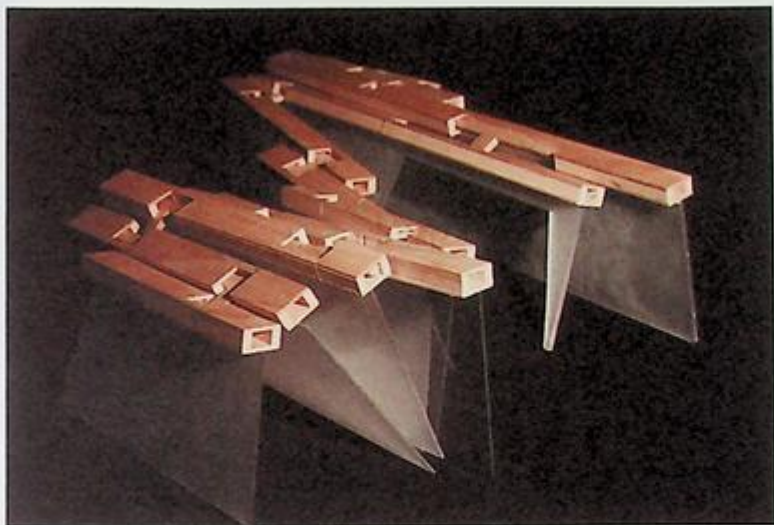

This acrylic, glass, steel, and wood model illustrates concepts derived from a drawn analysis of the expansion of a cheetah's spine and the lowering of its body as it accelerates. This model represents an intermediate stage in the

development of a design for a structure capable of physical expansion as it adapts to variable site configurations and circulation routes.

Student: Lisa Zhu  
(faculty: Val Warke and Jim Williamson, teaching associate; Larisa Ovalles)



Le Corbusier's de Beistegui Penthouse (completed 1930) was located atop a nineteenth-century apartment building on the Champs-Élysées in Paris. It is an essay on surrealist defamiliarization in architecture, whereby one term partially displaces another. In this view, a rooftop "room" has the sky as its ceiling, the hills of Paris as

its cornice, a croquet lawn as "carpet," and the "fireplace"—which appears to "smoke" when steam is exhausted from a flue behind the wall—as an Arc de Triomphe, suggesting simultaneously that the Arc de Triomphe is a fireplace (that does not function) and that every fireplace might aspire to being an Arc de Triomphe.

There are consequences to defamiliarization: when practiced by the producer of a work, an understanding of the unfamiliar is inevitably and eventually practiced by its perceiver.

#### Operations

Defamiliarization can play many roles in the design of a project and especially in the education of an architect. An architect may sketch a mountain silhouette that later becomes a roof, dissect a fruit cart in a local market that later becomes a preschool, translate the translucent tessellations of a Paul Klee painting into an urban design, or apply a pig's penchant for wallowing to a design for desert structures. Mining the unfamiliar often results in an expanded inventory of forms, contextual and environmental responses, and analytic and representational techniques.

#### Appropriation

Architectural concepts can be derived—through analysis and conceptualization—from virtually any artifact, even those that are not explicitly architectural (such as a tree, a beetle, a crinoline, a periscope). The appropriation of forms, operations, or representational methods from the investigation of such sources is one of the most common techniques a designer can employ in defamiliarizing a design process during its early stages.

Even the tools of design can be redefined: one can challenge the implications of representational conventions (a photograph might be interpreted as a plan, a silhouette as a basis for a model), or unlikely objects can be incorporated in a representation (children's toys in a model, anatomical illustrations in a section).

It is the discovery of a fluid relationship between things—forms, contexts, functions, and scales—that consistently renews our understandings of the world around us, suggests new questions, answers previously unresolved problems, and initiates one of architecture's most powerful discursive capabilities.

#### Subversion

Another technique involves the "overthrow" of a form or formal complex's traditional values or relationships, perhaps by upsetting its hierarchical status (a kitchen might supplant a living room's predominance, an electrical substation might be a civic monument), by making it nonfunctioning or dysfunctional (a gabled roof is filled with holes, a staircase goes nowhere), or by distorting its customary social value (a shunned subject is framed as if an object of reverence, a private space is made very public).

Ludwig Mies van der Rohe's German Pavilion for the 1929 International Exhibition in Barcelona (rebuilt 1984). Introduced modernism to an unaware audience using simply walls, columns, a floor, and a ceiling. Large, polished planes of glass and marble appear to wander, unadorned throughout the pavilion, touting the virtues of an independent column grid and "free plan" space. Defamiliarized by reflection and controlled illumination, marble surfaces dematerialize before our eyes as glazed surfaces solidify. The thickest wall in the pavilion is actually a well of translucent glass: milky and luminous, it casts no shadows. And as the glass wall symmetrically disposed between the black pool and carpet within fluctuates between being a vitrine and a mirror, the carpet seems to ripple while the Georg Kolbe sculpture dances inside the structure.

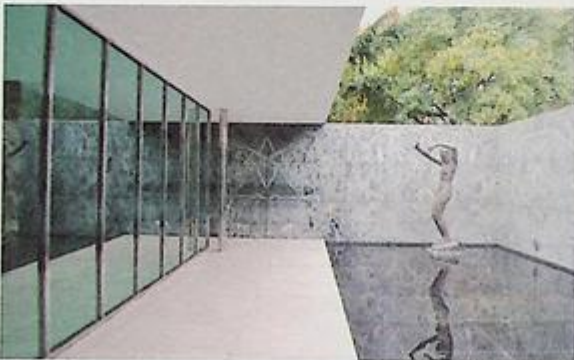

More than a simple inversion, the subversive operation in design may permanently and even retroactively reorient an observer's interpretation of a form as well as of all similar forms.

#### *De- and Recontextualization*

Because much of interpreted meaning is derived from the context in which a form is situated, relocating a form or system into a new—and possibly resistant—context will inevitably defamiliarize the original. When an opera house is placed beneath a highway, one's biases regarding the status of the institution may be altered, taking with them the material aesthetic sensibilities of the project. When a tenement becomes isolated in a park, it begins to assume a monumental presence.

#### *Accident*

Occasionally, during a design process, an "accidental" understanding emerges from the misinterpretation—intentional or not—of a representation: solids might be interpreted as voids, paving as ceiling, a detail or an urban plan "mistaken" for a building. This could even be the result of misreading site or program data: An incorrect scale, an exaggerated or inverted topography, a demolished building may be absorbed into a proposal.

Alternatively, an actual accident might foster alternative understandings: a drawing may be damaged, reversed, or misprinted; a model fractured, incomplete, or inverted; a "wrong" word might be used in a verbal presentation. By disengaging intention from execution, the assimilation of such accidents can inspire a designer to consider an approach outside a familiar method.

In these instances, the designer, critics, and observant colleagues should remain receptive to the serendipitous potential such "accidents" might provide for defamiliarizing and reinvigorating a process. While "accident" is often considered an antonym of "design," many schools even attempt to promote the occurrence of such "accidents" as valuable opportunities for expanding a student's repertoire, an important aspect of self-education.

#### **Reception**

The work that proposes a defamiliarized view of the world often fosters in its observers a modification of *their* familiar world, although it would be incorrect to say that reception is an exact mirror of production, since cognition is always personal and temporal. Nevertheless, there is an illuminating force behind defamiliarization, one that permits designers and observers to consistently exchange roles.

#### *Receptivity*

Since all forms have promiscuous and unknowable pasts—no one can know all of their liaisons and manifestations—the acceptance of cursory, preconceived interpretations is the most efficient path for the observer. The viewer of a defamiliarized formal complex must be willing to reconsider forms within the entirety of a new context and to disengage some of these forms from their prior, more superficial denotations. Since many of these forms are fully present only in memory, the effect may be retroactive.

#### *Wonder*

Whenever one encounters something for the first time, especially when that thing is somehow extraordinary, there is inevitably a sense of wonder. Since the goal of defamiliarization is to prompt others to actually perceive for the first time something that has perhaps already been seen on countless occasions—to grasp the extraordinary in something that has been routine—the observer's first reaction may be one of wonder. The emotional tingle of wonder is generally followed by an inquisitive urge and, eventually, a critical sensibility.



The Caixaforum gallery in Madrid by Herzog & de Meuron (completed 2007) incorporates the brick body of a former power station, estranging its fundamental character: its stone foundation is removed; its brick envelope suspended above a sunken entry court; and a ponderous, oxidized steel volume erupts as an alien mansard. The manipulation of the older structure contests our understandings of brick as structure or

drapery, window as opening or marking, and building as entity or material. A familiar building is rendered unfamiliar, promoting previously unthinkable perceptions of architecture. The adjacent Vertical Garden by Patrick Blanc (2007) further defamiliarizes concepts of mass and material, with "wall" as "ground," suggesting a dislocation of the nearby botanical gardens.



Walter De Maria's *The New York Earth Room* (1977), curated by the Dia Foundation, consists of a second-floor Manhattan loft filled with 140 tons (127 metric tons) of dirt. Discovering the loamy-scented space in Soho not only underscores the rarity of earth in this part of the city—of country relocated into city—but it suggests a reevaluation of the elements comprising the space:

columns seem to "grow" from the dirt, lighting fixtures seem as sunlight penetrating a canopy of foliage, walls as fragments of a ruin. The persistent whiteness, almost a platitude in modern apartment lofts, exaggerates the unnatural contrast, suggesting a reciprocal artificiality between the vacancy of the loft and the soil permanently tilled for growth that never happens.

### Poetics

The defamiliarized form, shaken loose from its rote denotation, is free to develop new levels of connotation. With this "thickening" of architecture's language, observers become aware of architecture's capacity for poetic implication: Even the most prosaic forms begin to resonate with unfortold significations and possibilities. These poetic consequences may influence our societal, environmental, ethical, emotional, and esthetic prejudices and understandings.

### Extension of Awareness

When the vinyl wood-grained body paneling fell from a colleague's 1970s station wagon, she felt it was necessary to somehow cover the exposed splotches of black glue and rusted screw heads. Combining inexpensive, efficiency, and an architect's sensibility, she replaced the plastic wood with thin molded sheets of plastic bricks. The unremarkable wagon became a very remarkable object. While few people were willing to park next to it, many were willing to comment on what the wagon revealed of the suburban esthetic it engaged: "wood" siding on automobiles represents a very peculiar,

almost perverse, collision of vehicular and domestic cultures. For those observers, the defamiliarization of the cladding of an everyday, mass-marketed wagon—an object that would normally be visually consumed in a moment—initiated a thoughtful contemplation that would forever alter their perceptions of such wagons and, possibly, of artificial veneers and even industrialized domesticity.

Exposure to the unfamiliar aspects of the familiar, the habitual, and the commonplace not only discloses the lost and hidden meanings behind the forms in our world, but frequent encounters with the unfamiliar extend our abilities to "read" the world through forms.

Architecture's capacity for transformation  
can sponsor alternative programs, inhabi-  
tations, appearances, and performances.

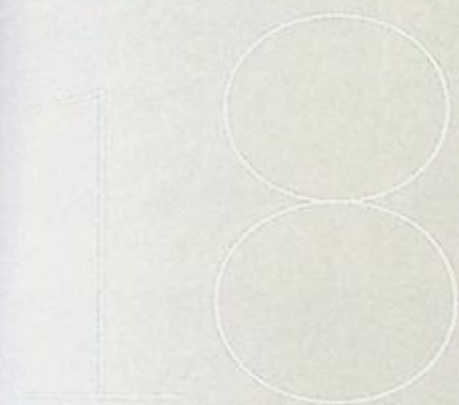

# transformation

**Transformations occur at multiple scales, from the smallest particle to an entire building, and at any interval, from a one-time event to a cyclical transformation.**

While the material of architecture might be predominantly static—concrete, steel, stone, glass, wood—the *experience* of architecture can be a highly dynamic one. Architecture has the capacity to transform from minute to minute, day to day, year to year.

Ernst Giselbrecht in 2005-07 created the "Dynamic Façade" for the Kiefer Technic Showroom in Bad Gleichenberg, Austria. Here an independent surface of perforated light metal bilfold panels can be positioned in an infinite variety of ways,

allowing for both personalized orientations and environmental responsiveness. The origami-like surface continually transforms the experience of the building and the landscape from within and from without.



By inserting a series of full-height steel doors into the vast, seemingly limitless space of the former slaughterhouse structure, Itaqul Carnicero's 2012

Hangar 16 in Madrid, Spain, creates multiple spatial readings that also facilitate a range of programmatic scales—from intimate art openings to full-blown rock concerts.



These transformations can be literal, implied, or often both. In other words, a panel can slide from one position to another, or as light moves across its surface, it can transform from reflective solid to transparent. But in all cases, this transformative capacity can sponsor alternative programs, inhabitations, appearances, and performances—in other words, architecture really is never very static at all.

#### **Literal**

A kinetic architecture not only registers and adapts to the effects of external stimuli but it also provokes behaviors as a function of its transformation. External stimuli can be environmental (shutters adapting to the

movement of the Sun), programmatic (a train compartment transforms from living room by day to bedroom by night with the lowering of the bunks), or spatial (a volume enlarges as its occupancy increases). Transformations occur at multiple scales, from the smallest particle to an entire building, and at any interval, from a one-time event to a cyclical transformation.

For example, it is very common in modern theaters for the audience/performance relationship to be physically altered by rotating stages, lifts, and movable loge seating; while projection technologies can perceptually alter the sense of enclosure, weather, and time.

#### *Temporal (Animation)*

Architecture registers the passage of time. Embedded within its transformations are the traces of human rituals and environmental stimuli. The sliding, rotating, opening, and closing of surfaces have the ability to transform spatial scales and relationships, determine conditions of public and private, and transform functions and operations.

#### *Topological*

Architectural space, form, and surface can also transform through the deformation of underlying structural patterns, based on mathematical models that subsequently inform the qualitative aspects of such patterns. As an alternative to literal

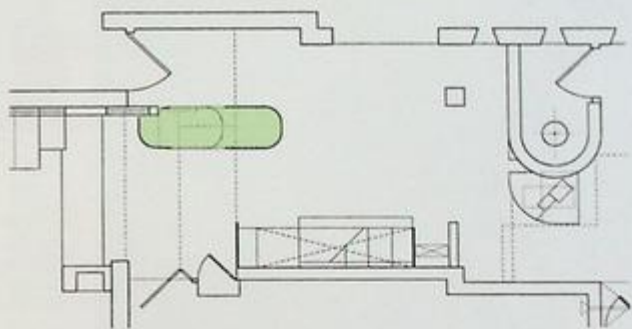
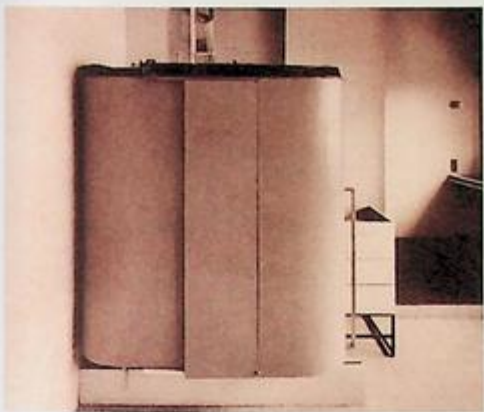

Eileen Gray's expanding wardrobes in *Tempe à Pallia*—the house she designed for herself in Castellar, France, from 1932–34, are but one example of an interior conceived as an enormous piece of furniture—where both surfaces and freestanding

furnishings transform to serve multiple spatial and functional programs. The entry hall's extendable wardrobe expands to accommodate its changing contents, but in doing so, transforms the entry hall's spatial sequence.

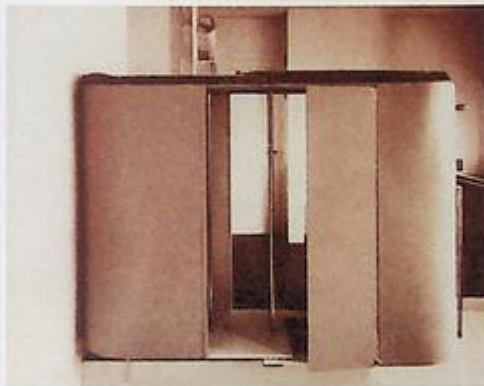

movement, these seamless physical transformations produce a fluidity of form where walls become floors become ceilings as they respond to programmatic stimuli.

#### Smart Materials

Programmable materials—synthetic materials that can be “stitched” into everyday materials and that self-activate when exposed to heat, water, and electricity—transform the surfaces and forms into which they are embedded through processes such as contracting, swelling, and thinning. Often these activations occur at the nanoscopic scale—the scale at which particles, hence material, undergo change.

#### Implied

Architecture transforms in nonkinetic ways as well, where the implication of transformation can reside in programmatic, formal, or perceptual interpretations.

#### Programmatic

Buildings that undergo programmatic transformation appropriate elements that were once designed for another specific purpose. For example, light projected through the stained glass windows of a church-turned-nightclub transforms the meaning of those windows from religious texts to disco balls. While nothing has physically changed, it is the context of the experience that transforms one's perception of the work.

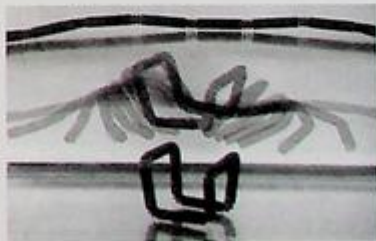

In 2013, Skylar Tibbitts of the Self Assembly Lab at MIT, along with Stratasys and Autodesk Inc., have developed a process whereby a composite material can expand and deform according to preprogrammed constraints. The blending together of a malleable material with a

polymer-based, water-absorbing material equips the resulting composite material with a built-in functionality when exposed to water, one that, when multiplied and introduced over a larger territory, anticipates the transformation of form as it responds to external stimuli.



In their 2009 design for the Astana National Library in Kazakhstan, BIG (Bjarke Ingels Group) combines a series of geometries to

produce a continuous spiraling path, a three-dimensional Möbius strip, that begins as a horizontal space but that shifts to a

vertical one, where the patterns of its surfaces map the thermal requirements of its changing orientations.

The ground floor of Norman Foster's HSBC building in Hong Kong (1978-85) is a permeable space that, during working hours, operates as institutional entry to the banking halls and offices towering above, yet on Sundays is transformed into a marketplace and gathering

space used by Filipina domestics. Plugged into an existing infrastructure of pedestrian, vehicular, and subterranean networks, it is a continuously transforming public space with the ability to be appropriated by an evolving urban culture.



#### *Theme and Variation*

Recognizable repetition that constructs a recognizable and cohesive overall "pattern" permits uniqueness and difference to exist within it without destroying the cohesiveness of the whole.

#### *Role of Perception and Memory*

Things once experienced in a specific way appear to undergo change when perceived from a context that has been altered. Architecture has the ability to anticipate, and even produce, this altered context. On the other hand, memories of previously experienced architectures rarely remain intact when revisited, as meanings are often drawn from and transformed by experiences collected over time.

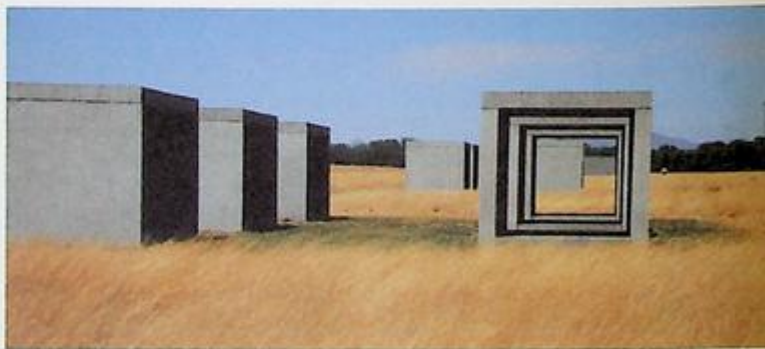

Donald Judd's 1980-84 collection of sixty-four 2.5 x 2.5 x 5 m (2.8 x 2.8 x 6 yd) concrete boxes distributed in fifteen clusters across the Chinati Foundation's valley in Marfa, Texas, are each constructed in one of several states of enclosure, from enclosed on all sides save one

to enclosed on only the two short sides. Any single volume does not literally transform, but when experienced as a collection, the implication is that each container and each cluster is a formal variation of the other, as if an animated filmstrip were dissected into

its individual frames and strewn across the landscape. The comprehensive understanding is of a form and of a space that is undergoing transformation—and as a result transforming the perception of the landscape in which they have been located.



Bernard Tschumi's Parc de la Villette in Paris, France (1982-98) presents a grid of thirty-five pavilions superimposed onto an open field to create an urban park. While each pavilion is related to the other in its basic dimension (10.8 x 10.8 x 10.8 m [11.8 x

11.8 x 11.8 yd]), its material (steel), and its color (red), each pavilion is a unique spatial exploration of the cubic volume, developing its specificity in relation to the spontaneous programs that they were intended to sponsor.



Through the carefully calibrated orientation of the exterior glass surfaces of Philip Johnson's 1949 Glass House in New Canaan, Connecticut, the solid plaster

ceiling of the interior is perceptually dematerialized, transforming the space into an exterior arbor supported by trunks of steel and bark.

Infrastructure introduces a systemic order, an identifiable armature to which other components can be subsequently attached.

# 19

## Infrastructure

**Infrastructural systems are intermediary devices between the requirements of the program for which they have been designed and the context in which they are located.**

Like the human body, buildings, cities and landscapes have intertwined layers of independent networks, or infrastructural systems, that work together to create a total system. A network not only serves a specific function, but that function, in turn, establishes the parameters of the network—its scale, its dimension,



The infrastructural network of Japan's highway system follows an entirely independent spatial logic than the cities over which it passes. Motivated by automotive access to dense urban conditions with severe spatial constraints, these layers of

highways produce an independent, constructed landscape. The Hakozaki Interchange of the Tokyo Metropolitan Expressway is a dense structural web of enormous scale, transforming the exterior spaces of the city into a cathedral-like interior.



Weiss/Manfredi's 2007 Seattle Art Museum: Olympic Sculpture Park blurs the boundaries between museum and city, building and landscape. Conceived as a continuous landscape linking the city's sidewalks above to the waterfront esplanade below, the museum's concept motivates all architectural and environmental decisions. At the urban scale, its undulating topography both houses the museum's principal galleries and service spaces and creates

uninterrupted circulation through the complex site, spanning existing highway and rail infrastructures while providing site drainage and remediation systems. Within the building, the topography is reiterated at a smaller scale, as a sequence that cuts through and connects its galleries. Finally, its exterior surfaces provide outdoor amphitheatres and exhibition areas, expanding the museum's cultural program into the city.

its functionality, and its visibility. And like an orchestra, where each instrument contributes to the overall symphony, each network is also independent, serving a specific purpose and behaving in a specific way, yet together they operate to create the larger work.

Infrastructural systems can be physical or ephemeral. As a physical network, they are intermediary devices between the requirements of the program for which they have been designed and the context in which they are located. A network of highways operates as an interface between the speed and turning radii of the automobile and the city or topography through which it passes. Alternatively, one may have an ephemeral network that is not physically constructed. For example, the Freedom Trail is a collection of buildings and sites where important events throughout Boston's history have occurred. It is an historic armature that crosses time and space, marked by a simple red line inscribed on the sidewalks of Boston.

### Physical

Infrastructure introduces a systemic order, an identifiable armature to which other things can subsequently attach. At a larger scale, infrastructure often becomes the connective tissue that links fragments of existing programs, creating a larger and more visible network. A series of parks can establish an urban infrastructural network, with individual neighborhoods organizing themselves, both culturally and physically, around a specific park along the network. Alternatively, a system of repeating structural pylons that supports an overhead viaduct might become an organizing device that serves as points of reference for the neighborhoods nestled below.

### Systemic Armatures

Like the grand structures of the Roman aqueducts, basic infrastructural amenities such as transportation, water, plumbing, electricity, and so on can operate as architectural armatures that spatially organize the complexes they serve. When visible, they become orienting devices that provide an underlying structure to the context within which they exist.



An abandoned rail line that once served to bring meat into lower Manhattan is transformed into an urban park, lifting pedestrians into a part of the city they were never intended to utilize. This now occupiable infrastructure reframes the urban experience as it develops a secondary route that engages the city in unanticipated ways, transforming the previously inaccessible backs of

buildings into primary faces, always demanding alternate forms of orientation and access. The continuity of this new linear park overlays an uninterrupted spatial experience onto what is typically the interrupted series of urban blocks and streets below.

Diller Scofidio + Renfro Architects and James Corner Field Operations with Piet Oudolf (Phases I, II, and III: 2009-15)



Introducing a formal circulation network into the informal hillside neighborhoods of Medellín, Colombia's Metrocable links the crowded and marginalized, often dangerous, communities to the city's primary subway routes. Floating gondolas that scan the densely populated landscape not only bring an audience to communities that are typically very insular, but the cable car stations introduce

a spine of commercial activity to areas that would otherwise be too dangerous to venture within, much less service. Here, infrastructure operates both as cultural lens and as connective and programmatic armature, transforming the context through which it passes.

Proyecto Urbano Integral (Integral Urban Project). The Metrocable San Javier, completed in 2008



Exquisitely thin armatures inscribe pedestrian movement over and through the Icelandic landscape—lifting skyward what appear to be mysterious traces of Viking passages. Studio Granda's 2003 Footbridges over Hringbraut & Njardagata

Introduce a series of structural ribbons that tip-toes three dimensionally across a newly constructed highway and from which pedestrians can experience an expanded and directed visual field.



At Álvaro Siza Vieira's 1977 Quinta da Malagueira housing community in Évora, Portugal, a system of raised concrete aqueducts not only provides the infrastructure necessary for water and electric distribution but also an armature to which each of

the separate residential clusters is attached. The structures that support the raised channels overhead mediate between individual houses and shops and the adjoining public spaces while creating shaded loggias along which the residents circulate.



One of the ten themed gardens at Parc de la Villette in Paris, France, Alexandre Chemetoff's Bamboo Garden (1987) is sunken below the rest of the park. In so doing,

it not only creates an isolated and unique ecosystem of bamboo forests and falling waters, but also exposes the layers of infrastructure that normally remained concealed.

Here storm drainage pipes become elevated thresholds beneath which one moves, assembled into a network of bridges and walkways hovering above.

### *Scales of Engagement*

Bus stops, street furniture, fountains, street lighting, and the like, are infrastructural elements whose details, textures, and dimensions introduce a scale of engagement that mediates the human body with its larger environment.

### **Evanescent**

Making visible what is typically invisible or appropriating existing infrastructural elements in surprising ways are devices that can raise ecological consciousness, often introducing an unexpected dimension to an otherwise necessary, yet prosaic, function. In other words, while infrastructural projects might be motivated by functional necessities, they can also provide shelter, recreational, environmental, and cultural amenities.

### *Cultural*

Processional routes can be important infrastructural systems that reside in the memories or behaviors of the cultures in which they occur. Sometimes unmarked, it is through their occupation that they momentarily isolate a particular route within an otherwise unremarkable context. Pasadena, California's annual Rose Parade celebrates

In the Netherlands, Thor ter Kulve converts the prosaic urban infrastructures of streetlights and fire hydrants, parking poles, and garbage receptacles into whimsical and unexpected programs. Temporary installations attach themselves directly to existing structures, interpreting their intrinsic and passive functions into playful urban interventions. A fire hydrant is transformed into sprinkler, a metal signpost into swing, a garbage can into barbeque, and a streetlight into glowing place marker.



In his meticulous urban renovations for Guimarães, Portugal (began 1987), Fernando Távora uses paving, an occasional fountain, and various infrastructural elements to initiate what is, in effect, an analytic dialogue

with the historic city, underscoring the bay rhythms and motifs of the city's more public buildings. Here, in Largo de João Franco, the round windows of the building at the end are translated into spheres of the

same diameter, which then serve a series of functions: as fountain ornament, as boundaries for the pedestrian realm, and even as parking bollards.





Constructed from the material in which they are located, rocky cairns, like these in Iceland, are an example of way-finding devices that mark routes through often inhospitable landscapes. From each one, the next is perceived, bringing measure to an otherwise infinite horizon.

the first day of the new year with flower-covered floats, horses, and bands as it follows a 5.5-mile (9 km) route defined primarily by the hundreds of thousands of spectators that line its sidewalks.

#### *Circulatory*

Circulation networks that are embedded within or overlaid upon existing urban landscapes are rendered "visible" by the bridges, shelters, or pathways that mark their trajectories. A bus route, for example, is populated at specific intervals throughout the day and night, marked by a series of shelters that line its path and that serve to trace a route that would otherwise be invisible.

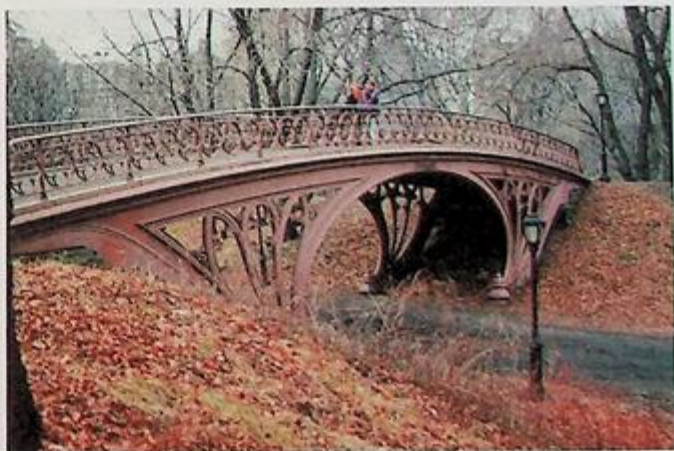

#### *Anticipatory*

An infrastructural network can be open-ended—explicitly designed as an incomplete system that provides the framework for transformation over time. Because the precise requirements for future usage can never be known, with changes in population, changes in technology, and changes in society and taste, the network that anticipates change will inevitably be the one that remains functional for the longest time.

Frederick Law Olmstead and Calvert Vaux's 1858-73 New York Central Park created a series of independent circulatory networks that was given material and dimensional specificity according to the particular program for which each was designed—be it vehicular, pedestrian, equestrian, or

aquatic. Additionally, the spatial experience, and often the separation of one system from the other, is achieved through sectional and topographic manipulation, carefully calibrated to choreograph views or minimize conflicting programs and experiences.



The five main arteries that constitute the backbone of the Bus Rapid Transit system in Curitiba, Brazil, are identified through their raised cylindrical steel and glass bus stops through which

the riders pass, purchase tickets, and access the buses. They provide not only shelter and functional requirements of accessibility and ticketing, but have the added functionality of news kiosks,

post offices, and small retail. Dimensionally and formally suggestive of the buses to which they allow access, the kiosks mark a route that would otherwise be invisible.

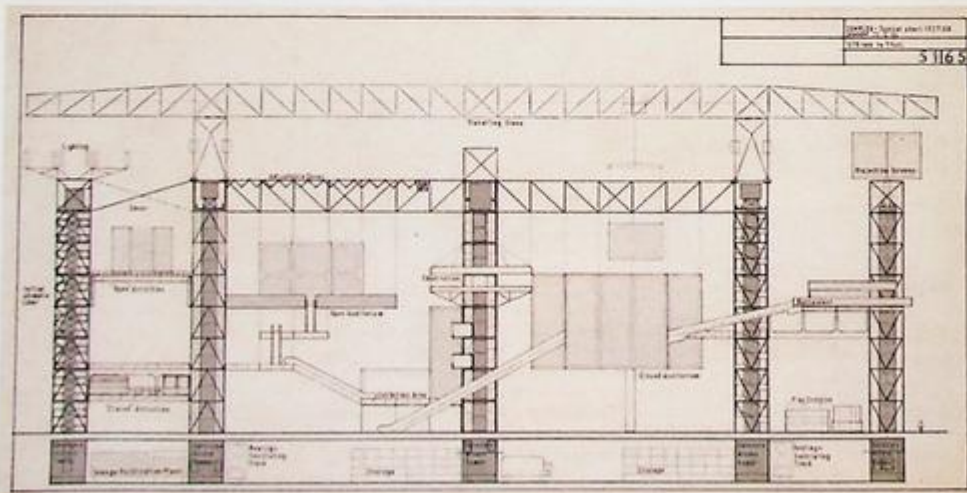

Cedric Price's 1960-61 Fun Palace is an example of a structural infrastructure—in this case a steel grid of occupiable columns (containing stairs, plumbing, electrical) and beams—one that anticipates programmatic elements that could be subsequently attached or suspended. These "plug-in" elements comprised floors, walls, and ceilings, as well as theaters, restaurants, and workshops; and, as with a theatrical production, the elements were to be easily mounted and dismantled to produce a continuously transforming environment.

In New York City, a series of urban infrastructural initiatives aims to construct the missing links of a continuous 32-mile (51 km) Waterfront Greenway Park that encircles Manhattan Island. SHoP Architects' East River Waterfront Esplanade (2007-11) is defined by an armature of plug-in programs that include bicycle and pedestrian paths, recreational, event, and community spaces with seating areas, all serving to define this urban infrastructure.



Alejandro Aravena's 2001 low-cost housing project, Quinta Monroy in Iquique, Chile, introduces an aggregation of standard concrete units that are intentionally incomplete,

with each unit subsequently and progressively modified by its inhabitants. An infrastructural field is introduced that facilitates individual transformation and yet resists total chaos.



A datum is the point of reference that collects dissimilar or random elements into a unified whole.

20

datum

**Common data are surfaces, spaces, geometric organizations, visual phenomena, and very large masses.**

A *datum* can be thought of as a singular and hierarchically identifiable object, space, or organization. It is the common denominator, the *point of reference*, by which dissimilar or random elements can be measured, located, or given dimension or scale. A datum can be composed of similar elements that, together, form a *primary and*



Le Corbusier's 1932-33 City of Refuge—or Salvation Army Building—aggregates the repetitive dormitory spaces into a hierarchically dominant linear building in front of which are collected a series of smaller unique buildings that

contains the communal spaces of entry, reception, and library. Here, the dormitory building operates as a datum that provides a common background surface for the objects arranged along its base.



Adler and Sullivan's 1886-89 Auditorium Building in Chicago, Illinois, is a multifunctional building of theaters, offices, and hotel rooms. Instead of expressing each floor as a separate entity, its façade collects multiple floors into discrete

zones (a base, middle, and top). This façade interface thus operates as a datum that simultaneously registers two scales: one of its interior organization that then gives way to the scale of its urban context.



In their 2004-07 public housing scheme in Madrid's new peripheral district of Carabanchel, Design Dosmasuno Arquitectos cantilevered steel-framed "object rooms" to extend the interior spaces that reside in the concrete "wall" of the primary apartment block that supports them. These additions reflect the variety of apartment types and sizes producing an ever changing shadowed texture onto the surface datum from which they are attached.

recognizable figure that has the ability to subsequently organize its surrounding "field." This datum figure can take on many forms: a surface, space, grid, axis, horizon line, mass, and so on.

A continuous street wall, for example, can be the organizing surface that connects a series of individual buildings. A courtyard can be the organizing space that relates the irregular rooms that surround it. An identifiable grid of streets produces an organizational structure that collects an infinite variety of individual buildings and programs. An axial

relationship between two or more elements establishes a visual datum along which other unrelated elements might be gathered. A horizon line or plane provides a singular visual reference that locates elements that are either below or above it. A mass is a recognizable volume from which spaces are excavated or objects are extruded.

#### Surface

A surface can be a principal organizing device as it provides visual continuity. Like a canvas, a vertical surface can provide the backdrop for a series of independent objects

(continued on page 169)

# John Hejduk's Protagonist Wall

In John Hejduk's Wall Houses, his multiple meditations over the tensions between the two-dimensional surface upon which artists and architects work (draw) and the three- or four-dimensional world that is depicted upon that surface is fundamentally important. In fact, one might say it is the whole point. As such, it represents an invitation for us to ponder basic questions about representation and larger philosophical questions about our place in the world.

In all of the Wall Houses the place of this tension is most clearly enacted by the wall, a datum that paradoxically both joins and separates the independent elements in the house's composition. Typically, the free-standing—and functionally purposeless—wall divides the support elements of the house (a ramp or passageway and services such as stairs and bathrooms) from the living elements (living, dining, and sleeping spaces). One approaches the house and enters through a threshold in the wall that would typically mark the transition from exterior to interior, only to find oneself on the exterior once again.

This experience is repeated as one passes through the wall and from exterior to exterior whenever one passes from one room to another. In this way, the wall is both the primary, mysterious protagonist of the house and also that element that structures a profound engagement in space and time; or as Hejduk himself stated, "The wall is a neutral condition ... It is a moment of passage. The wall heightens that sense of passage, and by the same token, its thinness heightens the sense of it being just a momentary condition ... what I call the moment of the 'present.'" (Hejduk, page 67)

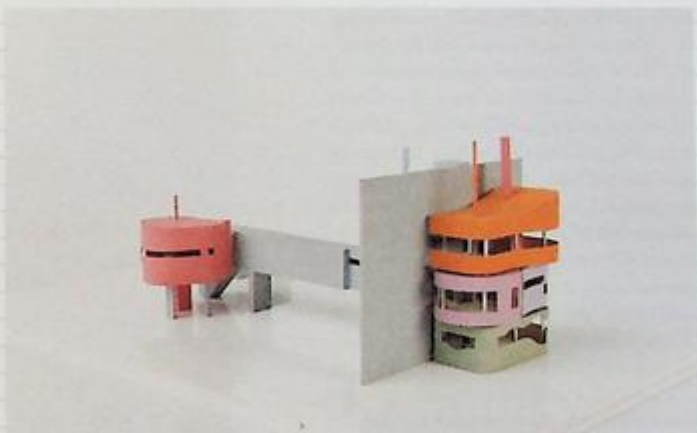

John Hejduk: Wall House 2 (Bye House),  
Ridgefield, Connecticut, USA, 1973  
Model by the MAI Collection

Hejduk was an architect who built very little but drew very much. The drawings of the Wall Houses, particularly the frontal drawings of the major living elements of the Bye House, embody some of his most important preoccupations with representation. This is the transformation of the three dimensional into the two dimensional and the moment that stands between them: the blank surface of a piece of paper. And it is made possible by Hejduk's use of oblique axonometric projection where plan and section are simultaneously present without the distortions of conventional axonometric projection.

Drawings such as these tend to "flatten" the illusory space of the drawing and emphasize the surface of the page. And in the case of the Wall Houses, this becomes true for the wall that is drawn upon it as well. In this way, the "present moment" to which Hejduk refers is also the threshold between the architect and an idea that he or she might project into the future. The datum, in this case, is the paper itself, the site—for Hejduk—of the mystery of architecture.

—Jim Williamson (Cornell University)

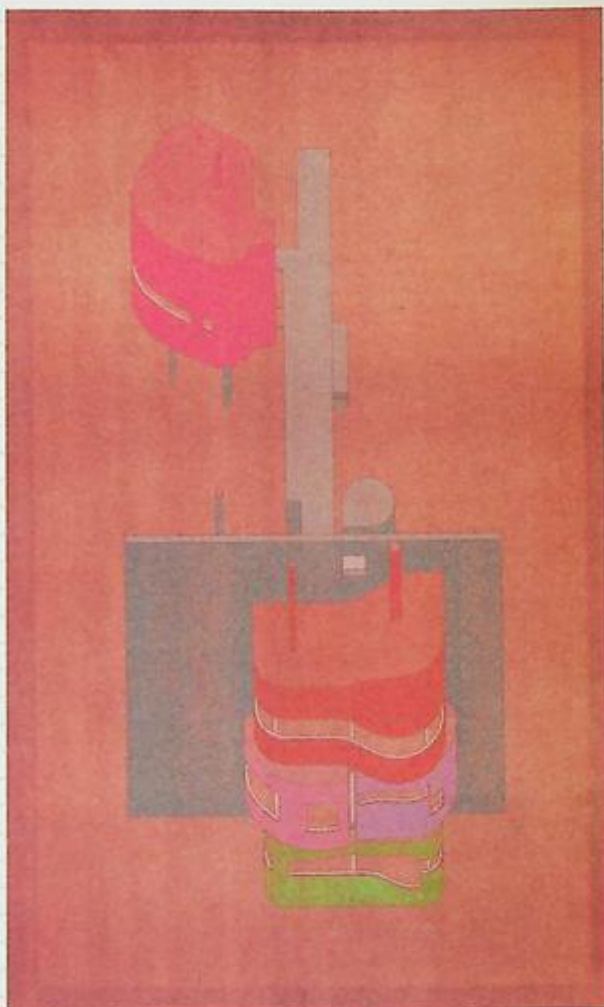

John Hejduk: Wall House 2 (Bye House),  
Ridgefield, Connecticut, USA, 1973  
Drawing by John Hejduk, Collection  
Museum of Modern Art, New York



At Bernard Tschumi's 1991-97 Le Fresnoy Art Center in Tourcoing, France, a new roof blankets the existing 1920s structures, collecting them beneath one continuous surface, producing a liminal space between the roofs of the old and the underbelly of

the technologically sophisticated new structure. And while the old buildings house the spaces traditionally associated with an art and education center—exhibition spaces, a library, a cinema, a restaurant, and apartments for faculty and students—the

addition of this new roof not only collects the existing and randomly organized buildings into a cohesive whole, but it produces a discovered space of walkways and suspended seating areas: an extension of the urban landscape beyond.

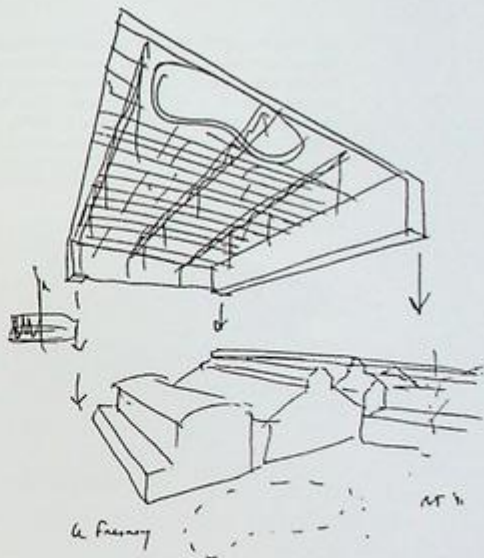

José María Sánchez García's 2011 project in Mérida, Spain, mediates between the archeological ruin of the Temple of Diana and the existing encroaching urban fabric, producing a perimeter wall on one side that makes a continuous backdrop for the temple and a cleared space in which the temple is once

again objectified, while also producing a continuous pattern of volumes on the other side that allows it to stitch itself into the dense urban fabric surrounding the temple. Here, the datum has two faces, operating as a mediator between two distinct conditions.

that might otherwise not have any spatial relationship to one another. It can also serve as an interface that simultaneously separates yet collects opposite conditions on either side of it. A horizontal surface, as in a large roof, for example, can act as an umbrella, one that collects smaller elements beneath it. Likewise, it can be a common base on which a variety of structures might stand.

### Space

Spaces are recognizable references that exist in both buildings and cities. Spaces with recognizable shapes—such as squares, rectangles, or ovals—act as orienting devices to which one often returns. These become especially recognizable references if they exist in contrast to a series of smaller spaces, as with a significantly larger space or exterior courtyard surrounded by smaller rooms or, within the density of an urban fabric, as in a public square or a larger avenue flanked by a continuous surface of similarly scaled buildings.

This is true even of curved armatures. The Grand Canal in Venice, for example, is not only an armature collecting the palaces that line its edges, but it is also a datum that provides spatial orientation within the city's dense urban fabric.

João Álvaro Rocha's 1991-98 National Veterinary Investigation Laboratory in the parish of Vairão in Vila do Conde, Portugal, is an example of a datum that physically constructs the circulation zone as a wall that links the head administrative block, the blocks of

laboratories of varying sizes, the employee cafeteria, and the oval animal corral at its end. This space of circulation steps down the sloping terrain as it provides the skeletal armature for the various building blocks that are plugged into it from either side.

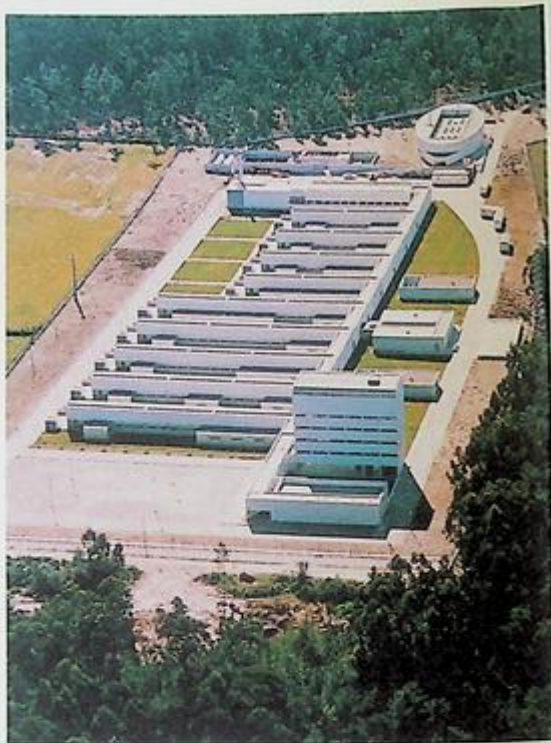

### Axis and Grid

An axis is a line that connects two or more things (this line might be folded or bent). It determines the relationship between a series of spaces or things. This line can be a visual and/or physical one, such as a line of sight or a procession along which one walks (as in a series of rooms *enfilade*). A grid, on the other hand, provides a reference field, a continuous framework of repeated and recognizable dimensions by which multiple objects can be measured.

### Horizon

The horizon is the line that literally separates earth and sky and, as in a perspective drawing, it is the line of human sight. In architectural space, the horizon line is a constant visual datum that locates and relates elements that are both below and above it. It is also the datum shared by both infinite space and foregrounded elements. Spatial depth is shaped by the continuous dialogue and fluctuation between this background and foreground.

### Mass

A dense volume can serve as a powerful physical datum—it can be a constructed object or a metaphoric ground. It is the mass from which occupiable space can be extracted or objects can be extruded.

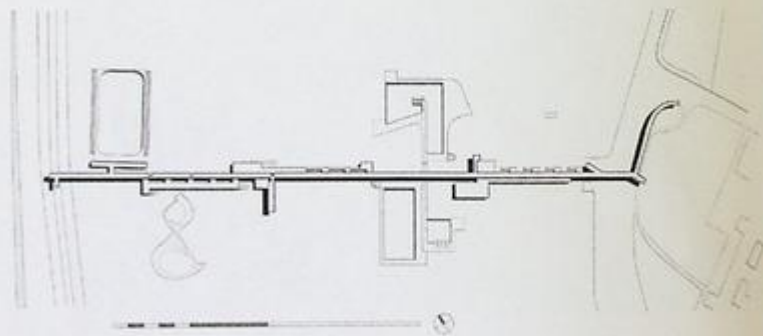

Aurelio Galfetti and Flora Ruchat's 1967-70 public pool in Bellinzona, Switzerland, is an elevated open-air circulation path that begins in the city and extends to the river, a linear datum that collects a series of pools and

sports facilities along its way. Nestled beneath the walkway are the entry stalls, changing rooms and facilities through which the pedestrians access the variety of pools below. The concrete path not only physically connects the

various programs at multiple scales but also provides a continuous line through which the sky, the horizon, and the landscape can be measured.

In Frank Lloyd Wright's 1908 Frederick C. Robie House in Chicago, Illinois, the unbroken rhythm of continuous fenestration reestablishes the horizon line of what was once an open prairie—a space captured between the planes of the cantilevered roof and continuous terraces and parapets. The domestic rituals of living and dining play out against this horizontal datum interrupted only by the vertical chimney mass.



20

Datum

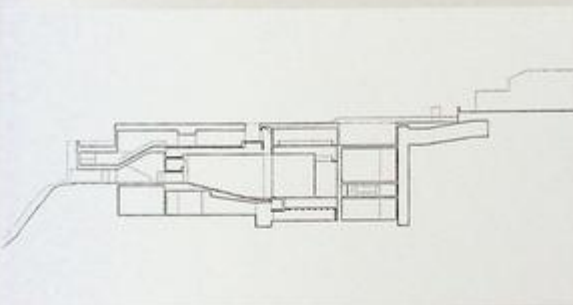

Paolo David's 2004 Arts Center—Casa Das Mudras in Madiera, Portugal, is conceived not as an object but as an extension of its surrounding landscape. This topographic datum produces a surrogate ground from which the occupiable spaces appear to be excavated.



Georges-Henri Pingusson's 1955–62 Memorial to the Martyrs of the Deportation in Paris, France, is located on the southeastern tip of Île de la Cité. The sequence into the memorial is initiated by symmetrical staircases inscribed into the horizontal ground plane of the island, bringing the visitor down into the space of the river below. Its interior spaces are subsequently excavated into the mass of the island, terminating with an infinitely projected hall of illuminated glass beads.

170

171

In architecture, the concepts of order that are evident in a design can affect our understandings of a design's intended uses, of its potential alternate use patterns, of its sociocultural milieu, and of its designer's attitudes and priorities.

# 21

## order

**A reason that the orders of architecture have occupied much of architectural is that they inevitably brought order to programs that were becoming increasingly complex.**

Whether because of an innate need or an intellectual desire, much of mankind's inventiveness—artistic and scientific—has involved a search for order, and for new systems of order when older systems seem insufficient. We look for order in nature and, if we suspect that it is not there, we find ways to formulate the disorder, to

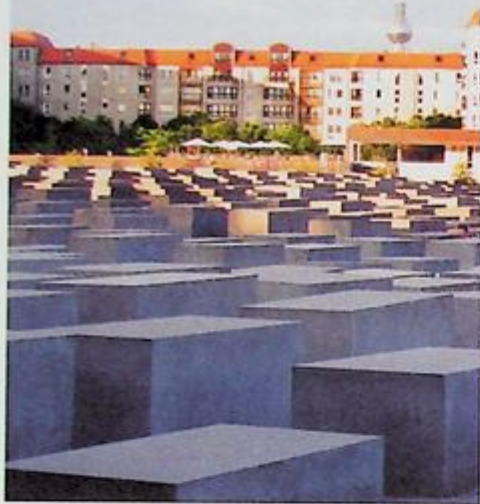

An undulating landscape of 2,711 concrete blocks of varying heights memorializes the approximately 6 million Jews who were killed during the Holocaust. The seemingly infinite pattern of blocks creates an intentionally

nonhierarchical space without orientation or reference, a city of the dead that is subsequently appropriated and brought back to life only by an engaged public. Peter Eisenman: Berlin, Germany, completed 2004.



Moshe Safdie's Habitat '67, (constructed 1964-67) in Montreal, Canada, arranges 354 externally similar, prefabricated concrete units stacked in three pyramids to produce a dense urban structure. The suburban prototypical characteristics of individual identity, exterior gardens, and

multiple levels are combined with the urban prototype of communal dwelling, building density, and collective amenities. Up to eight concrete boxes are linked in a variety of combinations to provide a range of dwelling sizes, each with multiple views and exterior terraces.

program randomness, to find complex layers of order in chaos.

In architecture, the concepts of order that are evident in a design can affect our understandings of a design's intended uses, of its potential alternate use patterns, of its sociocultural milieu, and of its designer's attitudes and priorities. This is as true for the design of a doorknob as of a city.

### Repetition

A basic design tenet has always been that "like elements should be treated alike, and different elements should be treated differently." This is especially helpful in large complexes when there is a field comprising many similar units (such as housing) against which one can identify a number of unique objects (community facilities).

Also, whereas some projects might be designed to suggest to observers something mysterious or ineffable, it is much more common that a work communicates a sense

of engagement—such as probable entries and possible destinations—and, at times, even a sense of program. An observer's recognition and identification of such components (the first stage of a discursive engagement) can occur at the level of the system, of the unit, or of the increment.

To this end, similar elements are most often placed together in a row, in a stack, or in a mat. The degree of similarity (as with two versus one bedroom apartments) or the irregularity of secondary attributes (terraces appearing off living versus dining rooms) may suggest an overlaid system, a counterpoint rhythm.

The apparently endless repetition of objects is undoubtedly dramatic in certain circumstances, rousing the sense of awe that can be inspired by magnitude. However, when the designer is required to accommodate a large number of similar elements for inhabitation—



The iconic form of the single family house has been repeatedly abstracted, repeated, and aggregated to form Vitrahaus—a showroom for domestic furniture designed by Herzog & de Meuron in 2004-09 in Weil am Rhein, Germany. A suburban field of

twelve iconic single-family houses has been repeatedly stacked, with each "house" focusing on a remote landscape. The intersecting volumes introduce an interior spatial complexity that cuts diagonally up and across the domestic shells.

(continued on page 177)

# Louis Kahn, Rome, and the Greek Cross

The dictionary defines order as "A condition of logical or comprehensible arrangement among the separate elements of a group." For Louis Kahn, especially after his experience in 1950 as a Fellow at the American Academy in Rome, the discovery of this logic became the main challenge in the design process.

Kahn discovered, in some of the ancient buildings of the city, a deep connection between the geometry that forms the space and the program for which it was designed. For example, the circle that generates the plan of the Pantheon is a perfect response to the structure's goal: defining a space for a multitude of divinities without preference for any individual god.

Frank Brown, a former history professor at the American Academy in Rome, taught Kahn that "the first Roman architects were the priestly leaders who prayed, made sacrifices, and asked the gods for signs. For these rituals of worship they framed the appropriate spaces." The idea that event generates space will be present for the remainder of Kahn's career, despite his defense of the "the room" as a generic space where various programs can occur: "Architecture comes from the making of a room," he said, and "[i]t is the creating of spaces that evoke a feeling of appropriate use." (Kahn, page 68)

The architecture of Andrea Palladio offered Kahn a great source of inspiration, particularly in the ways in which a geometrical pattern can be used to define a specific order and hierarchy among spaces. Similarly, Palladian villas would constitute excellent examples of the richness and variations that can be achieved between parts and a whole. Louis Kahn used the drafting table as a laboratory for discovering the patterns that

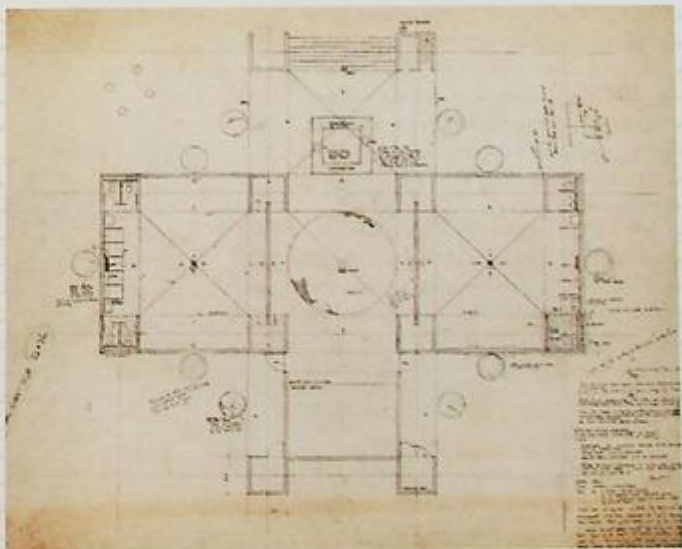

Louis I. Kahn (with Anne Tyng): Trenton Jewish Community Center Bath House and Day Camp, Ewing, New Jersey, 1954-59, sketch plan and photograph

define the perfect relationships between spaces. His design process generally began by defining a generic space—a room—with its own structural and functional identity, a unit he would repeat until fulfilling the program requirements. In his own words, "The plan is a society of rooms ... where it is good to learn, good to work, good to live." (Kahn, page 254) The process ends with the discovery of an overall geometry that perfectly adapts and transforms a collection of individual spaces into a whole.

After 1950, Kahn returned to Philadelphia and began using a specific form—the Greek cross, with its four equal arms—as a mechanism to provide order, constantly reusing it regardless of program or scale. We recognize this form as an obsession in designs such as the Trenton Baths, the Washington University Library competition, the Millcreek Apartments, and the Adler, Fleisher, and Goldenberg houses.

In some cases, Kahn implements this geometry as a constraint that would remain through the final version—in the Trenton Baths, for instance—whereas, in other cases, such as the Adler House, the Greek cross that appears in the early sketches disappears once the final program is installed into the plan and the house begins to address its context. Kahn consistently used the historically symbolic geometry of the Greek cross as the primary mechanism for initiating a comprehensive arrangement of the distinct elements of a plan's organization.

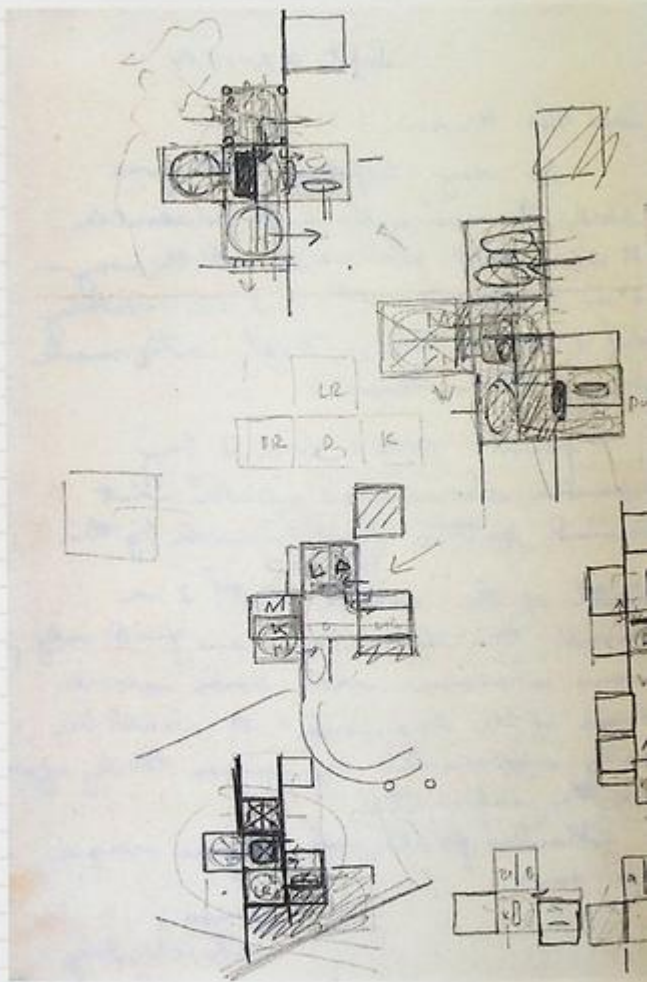

Louis I. Kahn: Adler House, 1954-55  
project sketches

—Itaqui Carnicero (Cornell University;  
Polytechnic University of Madrid)

often the case with housing, offices, or schools—the challenge is to avoid tedious repetition, ideally without resorting to arbitrary distinctions.

Especially with housing, it is often believed that the ability of people to identify their own units is an important aspect of promoting a sense of individuality within a context of community. The challenge is to develop distinction within a repetitive system, often accomplished by composing variable overall masses, arranging the units into several typologies (such as courtyards, slabs, and towers), or, often with less success, using changes in materials or colors to artificially indicate uniqueness. Of course, when every unit is treated distinctly, the opposite of particularity occurs; the complex is perceived as a uniform, mottled texture.

In projects founded on texture, especially those involving pattern fields, the manipulation of the pattern—three dimensionally, morphologically, through distortion or transformation—is the primary tool in developing a sense of variation and order.

A typical strategy in organizing highly repetitive elements is to emphasize the individual systems that comprise the

whole—circulatory, services, units, and possibly even structural and mechanical. It is often common to identify the various hierarchies that emerge within these systems, with, for example, entry circulation, vertical circulation, and horizontal circulation each given a distinct form. This can even extend to the level of the city, with hierarchies of vehicular traffic or public transit being articulated in terms of highways, boulevards, streets, and alleys, or hierarchies of building

heights or volumes based on degrees of public or private usage.

The organization of similar elements that vary only slightly (by volume or height, for example) can be accommodated through clustering or by serial sequencing, whereby both their similarities and their differences are identifiable.

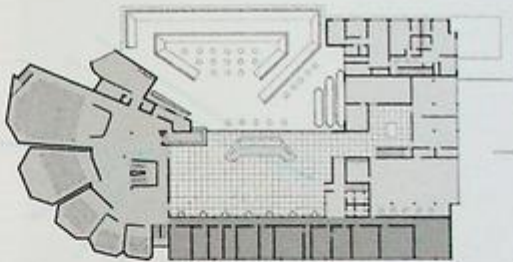

The four distinct programs of the Wolfsburg Cultural Center, designed by Alvar Aalto in 1958–62 in Wolfsburg, Germany, are organized around an exterior central court. The five lecture halls that comprise the adult education component of the

program are iterations of the same form, increasing in scale from the smallest which holds 26 persons, to the largest which holds 238, all fanning out as the principal marquis for the building's entry from the town square below.

HVRDV's 2001–12 Mirador in Madrid, Spain, takes the typical urban block composed of a series of individual apartment typologies surrounding a collective courtyard space, and conceptually hinges it 90 degrees to create a single vertical neighborhood of connected, yet still distinct, apartment complexes with the former "courtyard" becoming a window that frames the city beyond.

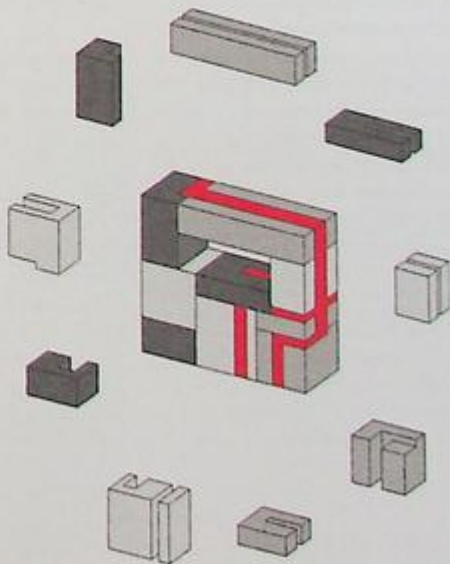
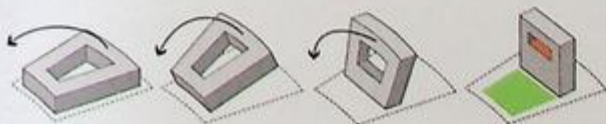

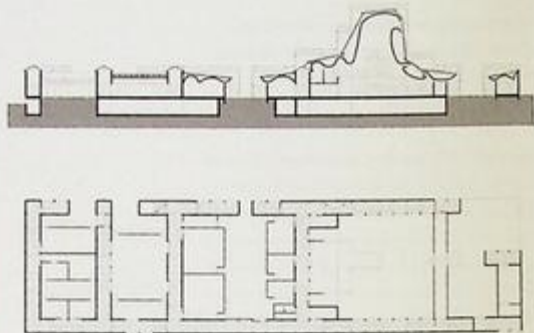
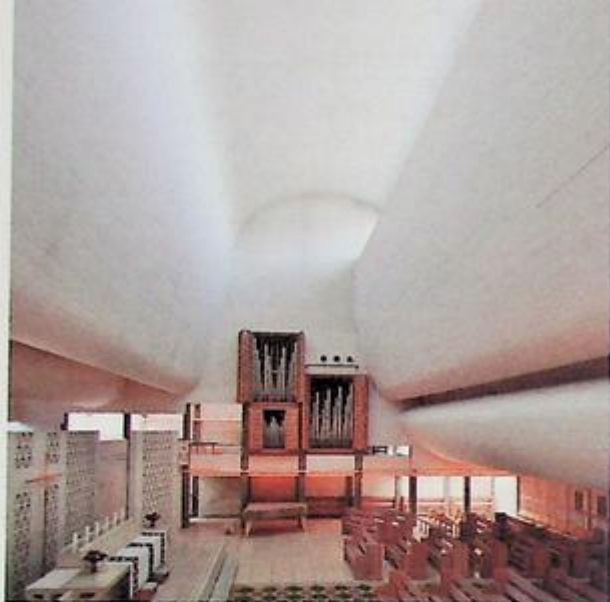

While the plan of Jørn Utzon's Bagsværd Church outside Copenhagen, Denmark (completed 1976), is extremely straightforward, the interior section is defined by an undulating concrete roof plane that begins with a

modestly dimensioned space above the congregation and builds to an enormous wave of concrete reaching toward the sky above the altar, capturing the Nordic light and drawing it deep into the primary space of the church.

### Aggregation

The designer is presented with different challenges when attempting to represent order when given a series of individual elements with little or no repetition. Decisions must be made regarding how the identity of the elements might be constituted and how conspicuous these identities might be. The designer must consider the varying scales that must be accommodated, even when those scales run counter to the relative importance of the elements. Finally, perhaps of the greatest consequence, is the problem of how the disparate elements might be associated. In situations involving the aggregation of such elements, the connective tissue—circulation, structure, services, surfaces—might, paradoxically, be the most important aspect of the design.

The designer may choose to merge a collection of distinct elements into the intrinsic differences of a city, dispersing a building throughout an urban fabric or simulating the production of a new city

fragment. The various programmatic elements might be given their own materials or even their own stylistic languages.

Alternatively, the designer might wish to suppress difference, to cloak everything within the same skin, possibly within a singular mass, so that only internal divisions determine the differences.

Similarly, a reason that the orders of architecture—Tuscan, Doric, Ionic, Corinthian, and Composite, among the most familiar—had occupied much of architectural theory from the Renaissance until the twentieth century is that they inevitably brought order to programs that were becoming increasingly complex. There were prescriptions regarding the appropriate hierarchies of orders and even suitable functional uses for the orders when used in a design. Each order proposed its own proportioning system. It was possible to understand the interior of a building by reading the orders used on its exteriors. A street, district, or entire city could be unified by subscribing to a consistent theory of the orders.

### Hierarchy

Hierarchy can provide an ordering system in which elements or groups of elements, while recognized as being related to an overall whole, are not necessarily of equal significance. It is this inequality that signals the relative significance of the part to the whole.

Hierarchies are revealed in every aspect of architecture's constitution. One can identify levels of importance in the composition of plans, in the development of sections, in the disposition of elevations, and in the production of distinctive objects or figural voids.

While a program might suggest hierarchies, the designer's determination of programmatic hierarchy can have great significance. When designing a city hall, for example, an architect communicates much about a government when determining whether the meeting hall or the mayor's office predominates in the building's organization.

Hierarchy can also be sociocultural. For example, the *mihrab*, denoting the direction

for prayer in a mosque, may be one of its smallest spaces, but it is also one of its most hierarchically important components, a focal point of the mosque. Or the only fragment of a village to have survived an earthquake may develop a special place in the new city.

When the components of a work are nested within each other—when the overall architecture frames other architectures, like a set of matryoshka dolls—the sense of order resembles the *mise en abyme* effect: the process of penetrating buildings within buildings reveals the relationships between the pieces. This is, for example, frequently the case in buildings like theaters and concert halls, where one moves through numerous distinct buildinglike spaces—entryway, lobby, stairways, loges, hall, and then (vicariously) the space of the stage with all of its autonomous architectures—each proposing its own identity.

While rare, the absence of hierarchy may be intentional in designs where complete equality or anonymity is desirable. And while a sense of order may be one of the basic human compulsions, human involvement can always be counted on to introduce an element of vital disorder to even the most rigorously ordered architectural designs.

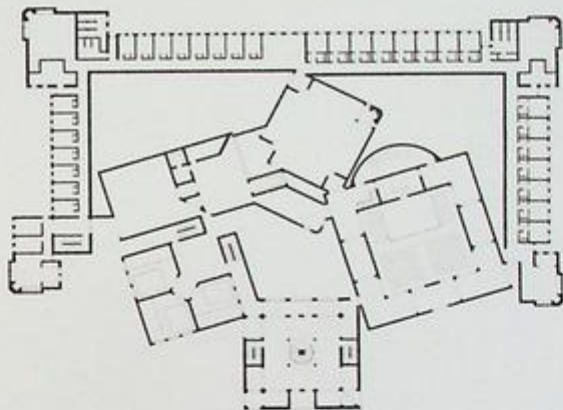

Louis Kahn's Dominican Sisters' Convent designed in 1965–68 organizes the cells into a perimeter wall, creating a large "container" within which is arranged the communal programs of the convent, with the exterior spaces between these primary figures and the enclosing cell wall forming a series of private "cloisters." The corner connections allow for a continuous sequence through the interior of the complex.

The forum of Pompeii is the primary urban "courtyard" around which the city's public buildings are gathered, and the first of a series of courtyards begetting courtyards. This organizing device of a primary space lined by subsidiary spaces is a frequent motif in ancient Roman towns. From the forum one moves to the basilicas and markets with interior spaces also organized

around large open spaces. Beyond are the residential blocks, with interior courtyards that both organize and bring light to rooms that surround them while choreographing the sequence that moves from the public street to the atrium and finally to the inner sanctum of the peristyllium (garden courtyard).

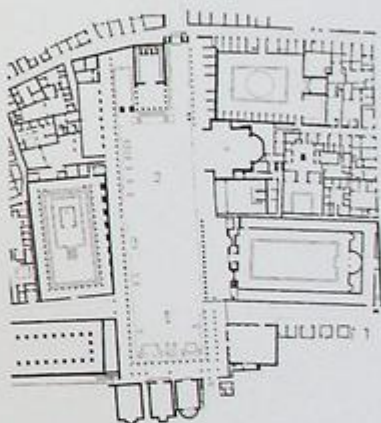

The two distinct semispheres of Oscar Niemeyer's 1957–64 National Congress of Brazil in Brasilia both house and represent the two principal government bodies, the Senate and the Chamber of Deputies. Juxtaposed against the low rectangular plinth in

which are located the complex's more public spaces, their forms demonstrate their programmatic and cultural significance. Additionally, the complex's siting on the capital city's main visual and organizational axis announces its significance at the urban scale.

A grid is the stage on which something might happen. It exists in anticipation of an event.

22

grid

**Without the ideal aspect of the grid, the distinctiveness of the incidental would go unnoticed.**

If there is perhaps one central phenomenon to all of architecture, from the smallest shed to the largest city and even, at times, to entire states and provinces, it is the *grid*. Given the expansiveness of the environment in which we live, laying out a grid provides an accessible field of operations for the designer. It provides a

A gridded "forest" of 856 columns fills the interior of the Mosque-Cathedral of Córdoba (first built 784–786, extended 833–852, 961–976, 987; current church inserted, with modification, in the sixteenth century). The various building campaigns are evident in the thickened walls and piers in this plan by James Cavanah Murphy, published in 1816, with the

cathedral being methodically inserted into the midst of the column field. Despite their uniform layout, the columns—reused from various Roman and early Christian constructions—retain their individualities, each telling of a different past. Their rhythm and regularity is alternately disorienting or serene, facilitating meditation and reverie.

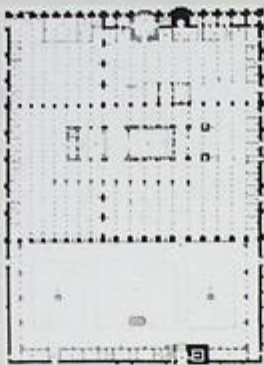

means of marking locations within a potentially boundless field. From the earliest days of human settlement, the grid has represented humankind's attempt to organize nature, to propose an order, even where a sense of order seems ungraspable.

Grids are always implicitly infinite, and so they end only by collision with a natural or constructed entity, with a predetermined boundary—such as a property line or a zoning envelope—or by the intentional decision of the designer. Still, while grids can suggest infinity, they also foreshadow their own ends. The regular pattern of a grid means that each section forecasts every other section, thereby already implying in their centers their eventual and probable boundaries.

A grid can be two dimensional—flat on the ground or on the surface of a building—or three dimensional, as in a structural grid. Grids often represent an ideal condition that can be replicated throughout a building or a site. It can be a condition derived from the proportions of the human body (as with the *tatami* mats of traditional Japanese residential construction), from an optimal dimension for spanning a space, from harmonic proportions derived from natural phenomena, or from the apparently efficient accommodation of a programmatic requirement (as with classroom sizes, parking bays, and hotel rooms).

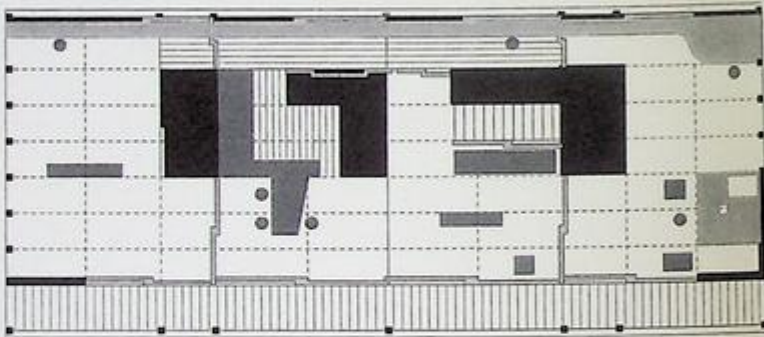

Since the sixteenth century, the rooms of traditional Japanese homes were often composed of an array of *tatami* mats, usually made of rice straw and in a 2:1 proportion, with its length close to the dimension of a prone human body. These mats bring not only a sense of gridded order to a dwelling

but also a refined sense of proportion. In his own home in Seijo (1953), for example, Kenao Tange combines a grid of *tatami* mats and sliding *fusuma* screens with a very slender wooden skeletal structure and an open plan to achieve a modern version of the Japanese house.



# Mies van der Rohe and the Grid as Site

The grid is the beginning and end of Mies's architecture—the site of architecture's emplacement and its eventual effects. Mies's grid operates on two different planes. The first plane is the plane of *Idea*. The grid on the plane of *Idea* is a template comprising instructions for organizing forms, materials, and functions to which it stands in a transcendental relation. This grid is deeply imbricated in the history and discipline of architecture, which provides specific precedents (Schinkel, Behrens, and Wright among them) and guarantees rigor and relationship. Consider, for example, the urban connections organized by Mies's plan of IIT, where the grid—originary diagram of the *polis* itself—represents the ideal urban condition of Chicago's South Side. Or the metrically controlled surface of glass and metal panels at the Seagram Building, which confronts metropolitan chaos with the sheer materiality of abstraction.

Mies's grid operates simultaneously on a second plane, which is a virtual site where architectural experiences and events circulate, combine, and recombine. It is the plane of *Event*. This plane hovers just above or just below the actual elements of architecture, more like a field of potential charged by invisible forces than a thing or even a geometry. The grid on this plane is not an inaugural ground or the source of an idea. Indeed, the grid on this plane is but a shimmering phantasm, the constant flux of immanent material and spatial images. Here percepts and affects are organized into material architectural experiences. Examples of such experiences include the

perspective-negating fluctuations of vision produced in Crown Hall, where the glass is frosted to a line just above the horizon, thus forbidding access to the stabilizing vanishing point; or the whirl of space in the plaza in front of Seagram's vibrating surface, as well as surface qualities like reflectivity, refractivity, dullness, and blankness; or the 6-foot (1.83 m) deep roof of the New National Gallery, floating on trabeated whispers, disturbing the certainty of stability of the earth itself. This second plane brings together heterogeneous elements and makes them function together, creating unprecedented and continually shifting relations without unifying or fixing them. The vocation of this plane is not to produce a whole but to constantly search for the new. Its nature is virtual and abstract.

Thus the grid as site comprises both generative concepts and relational, sensual events. The grid announces and insists on architectural autonomy and authority, and yet is infinitely productive of difference and otherness. The grid is pure relationship, perhaps the degree zero of architectural thought.

—K. Michael Hays (Harvard University)



Ludwig Mies van der Rohe: S. R. Crown Hall  
Interior (with the architect), IIT, Chicago, 1956



Ludwig Mies van der Rohe: Seagram Building, New York, 1958

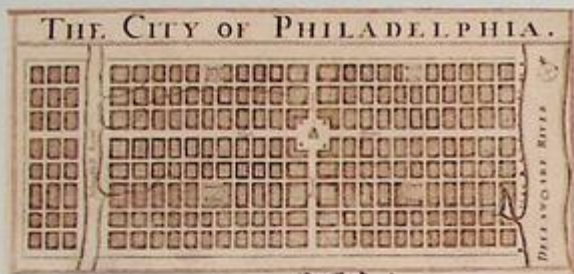

The founding of the New World required the founding of a multitude of new settlements that attempted to represent the colonies—and later, country's— aspirations for legislating and formalizing an egalitarian society by means of property divisions. In Philadelphia, seen in this detail of Thomas Holme's 1705 map of Pennsylvania—

presented by William Penn—the grid became the device of choice. But such neutrality is never ensured, if even desirable: the occasional park or nearness to water eventually alters the value of one property over another, so that the development of the grid inevitably becomes distorted by economic and environmental pressures.

Each grid type carries its own spatial and hierarchical implications when used to influence the organization of structure or partitions.

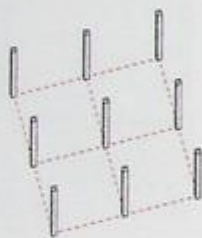

The four-square grid provides equal status to each of its quadrants and suggests a centrifugal movement pattern. Medieval chapter houses were often versions of this grid type, with a large, supporting column located in the center, branching into an ornate ceiling.

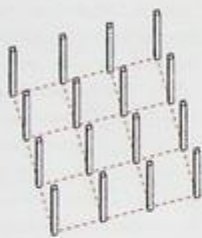

The nine-square grid, on the other hand, brings an inherent dominance to the space located in its center. Such grids were strongly preferred in church design, most evident in those of the equal-armed Greek cross plans in which the central element would be topped with a dome.



Once the grid reaches a certain density, the relative equality of the bays is ensured and the grid begins to imply infinite extension, although peripheral bays might assume some prominence, as in the case of market buildings.

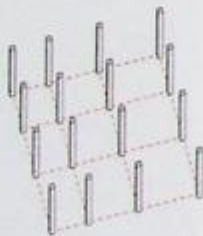

Irregular grid patterns, however, can relocate these hierarchies, suggesting, for example, diagonal developments.

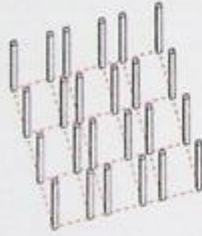

Irregular grid patterns can also create a mixture of major and minor zones as in a "tartan" grid, suggesting directional movements as well as possible service and stair precincts. This is an organization common among villa designs from Palladio onward through Wright and Le Corbusier.

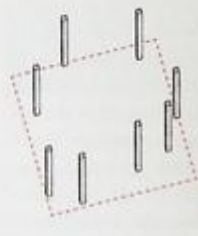

Of course, not every building utilizes an obvious grid. The absence of a grid makes the columns or partitions dominant elements of the composition. This situation can emphasize the presence of a casually defined space, like a clearing in a crowd.



The surfaces of Charles and Ray Eames's own house (Case Study House #8) in Los Angeles, (completed 1949) consist of a regular steel grid approximately 7.5 x 8 ft. (2.3 x 2.4 m) tall, with additional sub-components between the floors. This grid not only summarizes the architects' aspirations for industrial prefabrication but also generates both structural elements as well as interior partitions, collects a variety of infilled elements, and lends the overall structure a unified system while visually organizing the trees on the site.

But it is also a function of the grid, fundamentally neutral and indefinite, that the intentional disruption of its regularity—through the introduction of a rotated grid, sudden shifts in bay sizes, or the insertion of figures that resist conformity—can bring note to unique or special elements. In the later grid paintings of Piet Mondrian, for example, the variable grid itself becomes the subject of the work. Without the neutral, ideal aspect of the grid, the distinctiveness of the *incidental* would go unnoticed.

### Reference

Just as a Cartesian coordinate system provides an essential tool for understanding the characteristics of various points, lines, and figures, grids permit occupants of an architecture to fully understand the *locations* of elements within a space, from columns and walls to constructed and inserted furnishings.

Another important trait of the grid is its usefulness as a *measuring device*. As discussed in chapter 11: Space, grids can provide an indication of height and width, and a useful indication of spatial depth. After walking through one bay of a grid, we develop a sense of cadence and an anticipation of our further movements through a space. In this sense, grids can be understood as demarcating linear measurements, volumetric measures, and increments of time.



The Carré d'Art in Nîmes, France (1987–93), by Norman Foster + Partners, provides one edge of a large plaza containing the Maison Carrée, a Roman temple from the first century BCE. Foster's building is itself a temple of expanding and contracting grids, with a huge but slender five-columned portico that contrasts with the regularity and density of the columns of the Maison Carrée, beneath which a smaller, six-columned volume corresponds more directly to the size and front portico of the monument. From the interior, the columnar grid of the Carré d'Art provides both a measure and a locator for the temple outside.



The grid has long been used as a device for the transfer of one image to another or from an actual figure to a drawn representation. In his *Draftsman Drawing a Recumbent Woman* from his *Four Books on Measurement*

(1525), Albrecht Dürer demonstrates the use of a gridded wire frame and an obelisk (in order to fix the location of the eye) in transferring a figure to a similarly gridded piece of paper.



Tartan plaids are composed of specified combinations of colored threads woven together in perpendicular warp and weft patterns of varying dimensions.

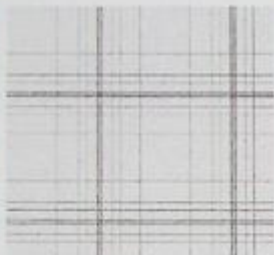

establishing a complex arrangement of varying color fields. In architecture, the "tartan grid" is a term used to describe a similarly variegated grid comprising

multiple rhythms of superimposed grids. On the right is a tartan grid derived from the "MacGregor of Cardney" tartan shown on the left.



For the final version of his courthouse addition to the Gothenburg (Sweden) Town Hall, completed in 1937, Erik Gunnar Asplund constructed a version of the underlying organizational grid that

structured the façade of the existing town hall. While this reductive approach was considered scandalous at the time, it has proven very successful in asserting its presence as a functionally

distinct component of the town government while maintaining a staid symmetry for the original structure and, at the same time, providing a consistent surface for one edge of a major public square.

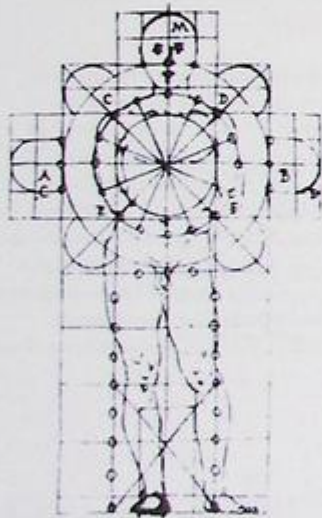

The proportions of the human body have been a frequent template for the disposition of grids, even when not at human scale, as in this sketch for a church design by Francesco di Giorgio Martini (c. 1492). This often follows from the

belief that the human body is shaped in the image of God, which would suggest that proportions derived from the body would transfer upon a building a divine and therefore beautiful harmony and coherence.

In one sense, a grid is the ultimate abstraction, most evident in its ability to legislate an order without being fully present; in another sense, it is one of architecture's most substantive mechanisms of comprehension. In the end, a grid is the stage on which something might happen. Grids exist in anticipation of an "event" that is then quantified and identified by its occupation within the gridded system.

### Rhythm

While structural grids are the most common, grids can be composed of *circulation* paths, *service* elements (like plumbing or lighting systems), *systems of furnishing* (such as library shelves or auditorium seating), or even *daylighting* elements (including skylights or windows).

Often, a grid may consist of more than one increment, as in the case of *tartan* grids, with their counterpoint of major and minor bays. Such complex grids can also be understood as an overlap of grids, with a consequent compounding of rhythms, hierarchies, and programmatic attributes.

Additionally, a grid can be generated from a *distortion* of an orthogonal grid, warping a pattern so as to imply a directional inflection, an adjustment to an irregular site boundary, the accommodation of an irregular insertion (such as a theater volume), or even an attempt to develop an exaggerated depth or shallowness by means of false perspective.

### Proportions

The selection of a grid's increment is perhaps the clearest way in which to develop a proportioning system that can permeate a building's design, unifying its parts with its whole. A grid might be based on specific *dimensions* (such as those of a standard human body, of a regularized work space, or of the predominant grid in a neighboring structure), or on proportional relationships that are independent of scale (as with proportions derived from string lengths in the production of musical chords).

*Regulating lines* have been an important aspect of architectural aesthetics since ancient times. Such lines are based on the characteristics of similar triangles—those sharing identical angles, regardless of the

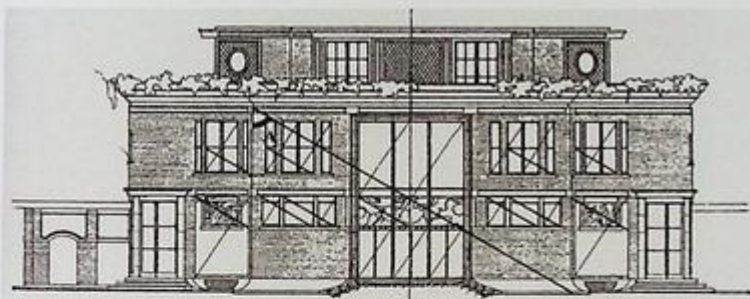

In his *Vers une architecture* of 1928, Le Corbusier dedicates a chapter to the importance of regulating lines, which he considers to be "an inevitable element of architecture" and a "basis of construction and a satisfaction." He illustrates this chapter with numerous buildings of historical importance, among which he locates several of his own, such as the Villa Schwob in La

Chaux-de-Fonds, Switzerland (1916). The repetition of angle  $A$  (and its complementary angle) across the elevations provides the villa with an intrinsically harmonic proportioning system whereby the proportion of the elevation's central block is present throughout the various subdivisions and fenestration elements.

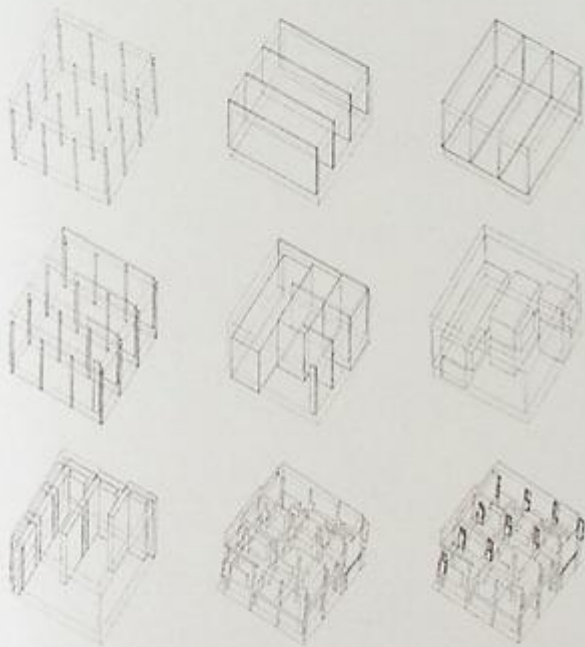

An "active" grid becomes the subject and object of Peter Eisenman's House II (1969) in Hardwick, Vermont. The building is the consequence of a series of three-dimensional manipulations of a basic nine-square grid—dislocations, solidifications, evacuations, transpositions—that leave traces that engender elements such as physical structure, spatial

figures, service elements, circulation systems, enclosure, glazing, and gradients of density. The result is a house that uses one of architecture's most fundamental and abstract components, the grid, as an all-encompassing generative device, eliminating nearly all the artifacts of traditional domestic architecture.

lengths of their sides. Such triangles will always share proportional relationships among their sides, so that the use of regulating lines in architectural design lends a consistent proportion to the entirety of the structure. For this reason, regulating lines are considered an effective technique for guaranteeing harmonic proportions throughout a building, from elevations to sections to plans, with regulating lines often providing the basis for variations and subdivisions within the fundamental grids. From the Renaissance onward, there was a distinct relationship between the use of such lines and the construction of linear perspectives, where similar rectangles would be used to imply the recession of a figure in depth.

Le Corbusier was one of modernism's most vociferous advocates of regulating lines—more often than not based on the *golden section* ratio—seeing in them "[t]he obligation to order. The regulating line is a guarantee against arbitrariness. It brings satisfaction to the mind." (Le Corbusier, page 132) Despite this, very few of his contemporaries had enthusiasm for what was inevitably considered to be a remnant of the architecture they were trying to leave behind.

A knowledge of geometry not only provides the architect with the ability to represent and communicate basic ideas, but it is also an essential aspect of understanding the genuine and illusionistic aspects of architectural space, for calculating the actual surface areas and volumes being described, and for describing the potential fabrication of forms to others.

# 23 geometry

**There is a certain aspect of descriptive geometry that prefigures the visual impact of certain forms: geometry can present not only what something physically *is*, but projective geometry can also prefigure *what can be seen* from specific viewpoints, and how complex figures can be broken down into buildable components.**

As alchemists sought inscrutable objectives that included philosophical and spiritual insights, material transmutations, astrological projections, and even immortality, they forged a path that led them to discoveries in sciences such as chemistry and medicine. Similarly, architects

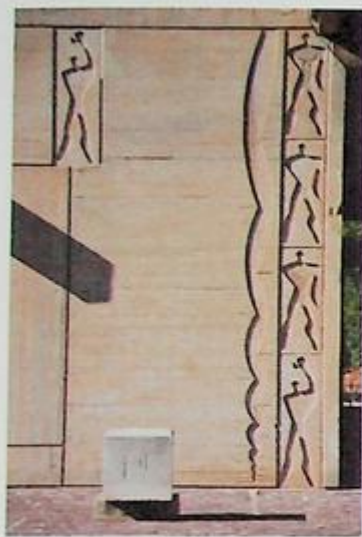

Le Corbusier's Modulor 2 proportioning system begins with the height of a 6-foot (1.83 m) person—the ideal English detective hero, according to Le Corbusier—with an uplifted arm at 7 feet, 5 inches (2.26 m), subjecting the increments to subdivision by means of a Fibonacci series. His belief was that the

use of these proportions throughout a building would assure a harmony of the parts and a sense of human scale as well as to foster the development of potential standards for building materials and fixtures. It is here imprinted on his *Unité d'habitation* in Marseille, France, of 1947-52.

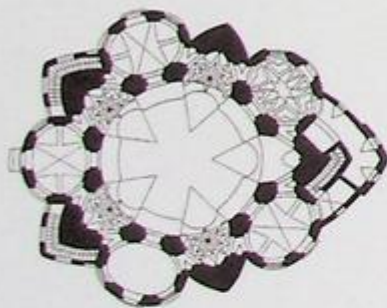

In Jan Blážík Santini's exuberant Church of St. John in Nepomuk at *Zelená hora* in *Žďár nad Sázavou* (Czech Republic, 1721), the numbers five and three—which figure prominently in the saint's hagiography as well as Christian theology—symbolically

appear in every aspect of the building complex, often combined with the figure of a tongue, relating to the legend of St. John's martyrdom upon his reputed refusal to break the silence of the confessional.



The golden section rectangle has been used throughout much of architecture's history as a proportioning tool. Here, it is superimposed on Michelangelo's restructured façade for the Palazzo del

Senatore in Rome (completed in the seventeenth century), revealing golden ratios between the base and upper stories as well as within the overall dimensions of the surface.



Vincenzo Scamozzi's Palmanova (designed 1593) was considered to be the ideal fortified outpost city of the Venetian Republic. Its original ramparts form a nine-pointed star with its three entry boulevards culminating in a hexagonal central piazza. Its geometries—nonagons

merged with hexagons, squares embedded in trapezoids—combined optimized strategies of defense with Renaissance theories of ideal proportion and universal harmony. As with most intended utopias, Palmanova's idealization has proven uncongenial to everyday inhabitation.

with diverse utopian aspirations, including the idealization and optimization of various spiritual, cultural, aesthetic, material, health, and environmental goals, have found their paths most frequently plotted through geometry.

For thousands of years, most architecture has been composed of cubes, cylinders, spheres, cones, and pyramids. Perhaps more than the development of new materials, new representational techniques eventually accompanied by new skills in fabrication have caused architectural form to develop more elaborate geometries. Guilds of medieval stonemasons sharpened their skills as cathedrals reached higher. In the Renaissance, linear perspective expanded techniques for the study of descriptive geometry. Later, in the baroque, geometries merged and warped as stereotomic techniques were perfected and craftsmen developed skills in turning wood and ivory on lathes in fabricating exceptionally complex objects.

### Numbers

Perhaps the most pervasive and persistent geometries are those based on the *golden ratio*. Known since the time of Pythagoras, this ratio has fascinated mathematicians and

artists for over 2500 years. Golden ratios and their rectangles have a capacity for continuous regeneration and subdivision, and can be found throughout nature, from nautilus shells to the length of our finger bones, and it forms the basis for many investigations into five-fold symmetry (important in pattern theories). Perhaps because of its ubiquitousness, artists and architects have long considered the golden rectangle to be one of the most visually pleasing geometric figures.

The golden ratio is closely approximated by the more finite Fibonacci series—1, 1, 2, 3, 5, 8, 13, and so on—which approaches the golden ratio of  $1:\Phi$  (1.6) as it progresses. The Fibonacci series forms the basis for Le Corbusier's Modulor proportion system as well as numerous theories of plant and animal growth.

Religious and governmental architecture has frequently employed geometries for their symbolic significance, with equilateral triangles, squares, pentagons, hexagons, and so on being used in plan, elevation, and volumetrically in order to emphasize the liturgical or historical importance of certain numbers.

# Geometry of Pure Motion: Buckminster Fuller's Search for a Coordinate System Employed by Nature

Richard Buckminster Fuller, a self-proclaimed *design scientist*, is perhaps best known for his lightweight geodesic domes and his structural concept of tensegrity. While his applied geometries in a variety of forms—from tents to domes—served highly functional purposes for clients including the U.S. military, and also garnered numerous patents, Fuller's dedication to solving the world's problems through functional geometries was driven by a much larger obsession with the fleeting relationships between nature and mathematics. Fuller's obsession was rooted in an omnirational understanding of the universe, where form emerges from a continuous chain of connected events. He understood the limitations of the Cartesian system as it emphasizes fixed coordinates as opposed to coordinated variations of geometry and matter. Fuller was interested in a design space that embraces all the known mathematics from Euclidean to non-Euclidean. Therefore, he abhorred disciplinary "silos" as they fundamentally undermined his concept of *synergy*, that is "...the behavior of whole systems unpredicted by the behavior of their parts taken separately." Fuller's applied projects such as the Dymaxion House (a conflation of dynamic + maximum + ion) explored dynamics in form through the application of his synergistic principles combined with a search for structures that he considered minimal through a reduction of overall weight but were ultimately limited in their ability to change dynamically in response to environmental conditions. Interestingly, Fuller's concept of tensegrity, which he understood as a system of energy where space is not static, has subsequently been adopted by the pioneering cell biologist, Donald Ingber, as a model for understanding how cells are structured at the nanometer scale. Tensegrity may be simply

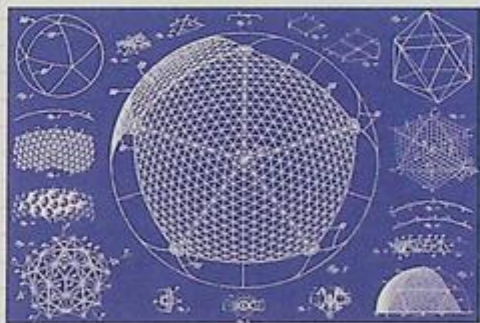

Buckminster Fuller: Geodesic dome  
(U.S. Pavilion, Montreal, Canada, 1964-67)  
drawing

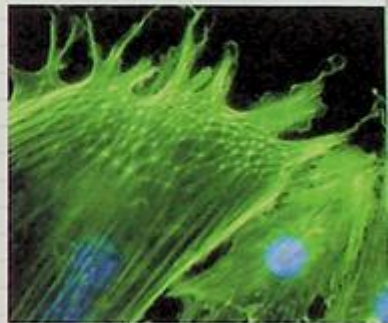

Donald Ingber: Geodesic form  
in the tensed cytoskeleton of  
a human cell, 2011

described as a network of discrete compression components held in continuous tension. Each member is dependent upon the next in a network of forces that undulates in an on/off fashion, much like the process of weaving. Fuller observed the efficiency and economy displayed by the sculptural work of the artist, Kenneth Snelson, thus leading to Fuller's term "tensegrity," a combination of the terms "tension" and "integrity."

Perhaps limited by technology and a modernist bias toward the reproduction of single parts, Fuller was not able to realize his theories of variation between parts and whole systems in his functional geometries. Recent advances in digital and fabrication technologies allow for the exploration of interconnected parts and material behavior, where forces external to three-dimensional tensegrity structures may influence and alter the continuity of the tensional forces and the discontinuity of the compressive forces. Ingber's link between the mechanics of the cell cytoskeleton with the dynamics of tensegrity is, perhaps, the closest translation of Fuller's

concept of synergy as it forms a bridge between the purity of mathematics and geometry with the instability and complexity of nature. Given the systemic properties of these lightweight skeletal assemblies, such structures are capable of changing in response to their environments. The result is a variegated tensegrity system where internal rule systems share reciprocal relationships with external and environmental forces. This differentiated behavior operates at the level of the individual components and at the level of the global system. Imagine these structures growing, contracting, and expanding in response to the presence of people, light, or temperature. Fuller pioneered a systemic design process, where flows of energy connect form with communication, geometry, and matter. Digital technologies and computational thinking have afforded a material translation of Fuller's "geometry of thinking" that will finally fully realize his functional geometries, as informed by the dynamics and complexity of an expanded context.

—Jenny Sabin (Cornell University)

In his treatise of 1547, *Le Premier tome de l'Architecture*, the French Renaissance architect Philibert de L'Orme illustrates his method of stereotomically representing the squinch—a vaulted transition between an inside

corner and a convexity—beneath a small chamber in the Château d'Anet. Careful reading of the drawing reveals the actual dimensions and angles a mason would need in order to accurately cut the seven pieces of ashlar.

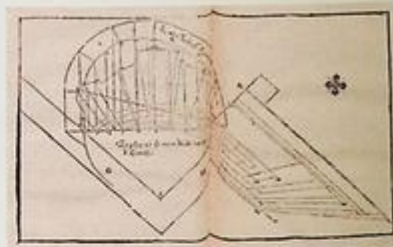
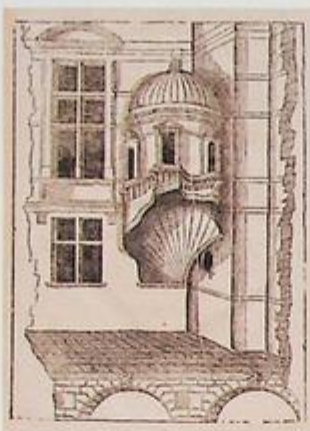

### Descriptive Geometry

Every architect can benefit from an understanding of the fundamentals of descriptive geometry (also called "applied" or "constructive" geometry). Not only is the ability to represent three-dimensional forms two dimensionally a necessity for representing and communicating basic ideas, but it is also an essential aspect of *understanding* both the genuine and illusionistic aspects of architectural space, for *calculating* the actual surface areas and volumes being described, and for *describing* the potential fabrication of forms to others.

With descriptive geometry, one can present not only what something physically *is*, but projective geometry can also prefigure *what can be seen* from specific viewpoints, and how complex figures can be broken down into buildable components.

Modern descriptive geometry also assists the designer in being able to identify and quantify linear curves in space, as well as the measures of warped surfaces and irregular volumes. But while many computer graphic programs can simulate much of the constructive aspects of descriptive geometry, allowing programs full control over the formation of such figures means that the designer becomes merely a consumer of predetermined forms and techniques. For example, rather than understanding a sphere as a singular geometric figure, certain programs

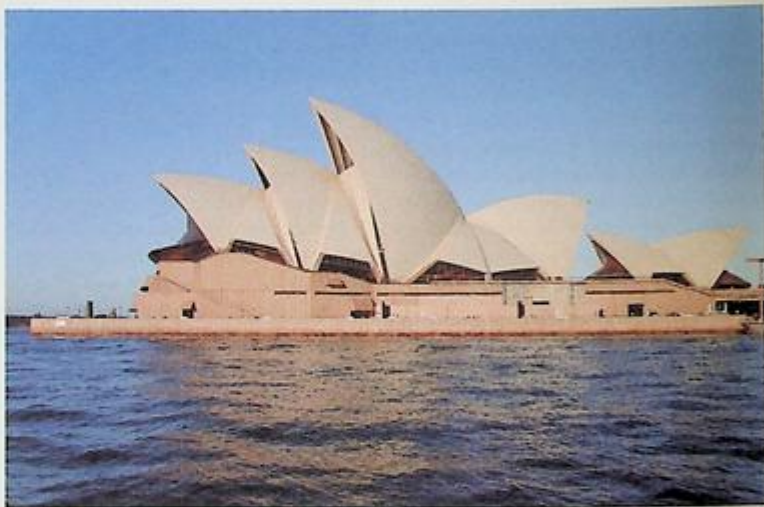

Amid concerns regarding the structural and constructional possibilities of the shells in the original design for the Sydney Opera House (inaugurated 1973)—especially based on the technologies of 1940—architect Jørn Utzon demonstrated with this

wooden model (c. 1961) that each of the shells could be a segment of the same sphere, meaning that curvatures would be identical, facilitating structural calculations and prefabrication.

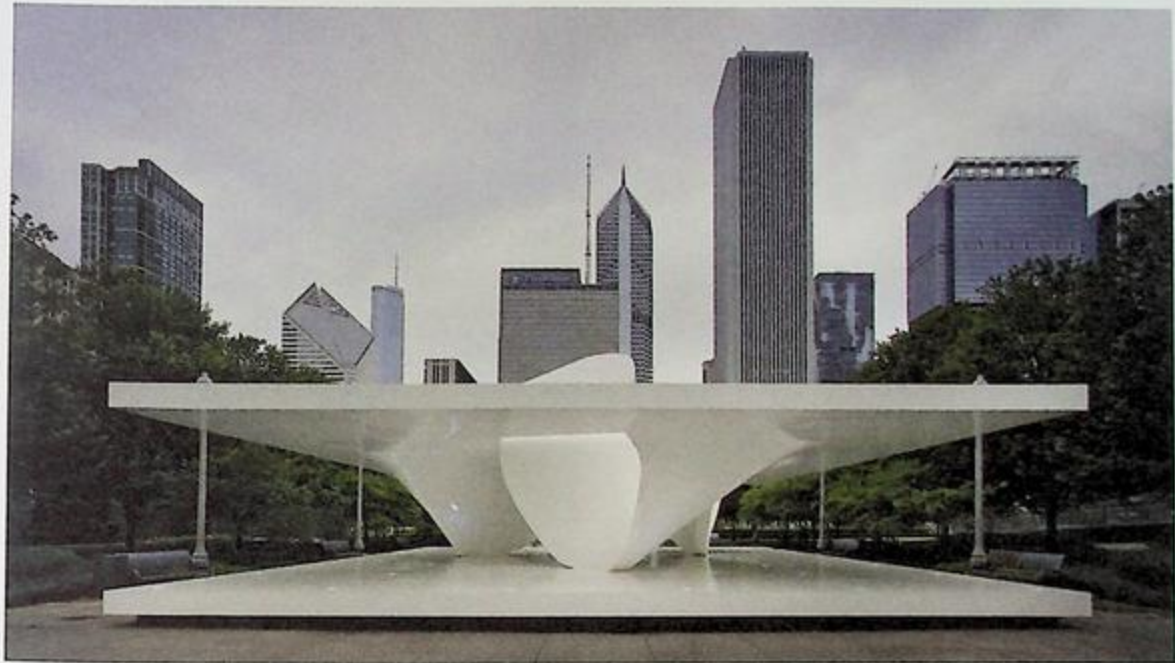

UNStudio's Burnham Pavilion in Chicago's Millennium Park (2009) begins with a platform organized on Daniel Burnham's famous Chicago grid as its initial figure and

then distorts the roof plane of this grid using various parametrics in recognition of specific vistas within the park and toward the city.

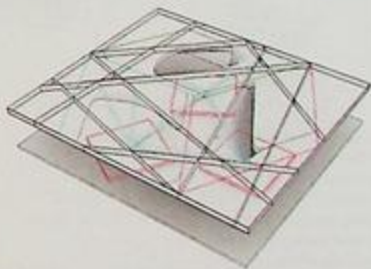
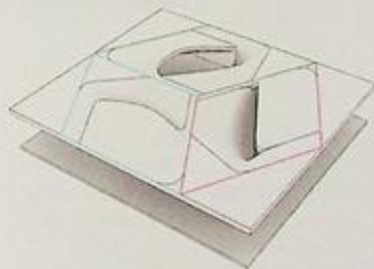

require it to be understood as a polyhedron that approaches an infinite number of sides, a hosohedron composed of lunes, or a circle rotating about one of its diameters. The version of the sphere to which one subscribes directly affects the transformations to which the sphere can be subjected.

### Complexities

The combination of forms through *Boolean* operations—merging positive forms (solids), positive and negative (subtractive) forms or more complex combinations resulting in the systematic addition or subtraction of overlapped forms—is one aspect of design that has become vastly facilitated by digital representation. Such Boolean operations are

central to constructive solid geometry (CSG) techniques of modeling solids.

Also, the use of *parametrics* in design has become a significant tool in the designer's repertoire, influencing every scale and aspect of design, especially in academic settings. Parametrics, at its most fundamental, involves the use of a set of parameters or limits—such as networks of circulation, patterns of congregation, or measures of daylight—as a means for exploring a range of geometries through multiplication, distortion, transformation, or all three.

Various *meshes* can also be introduced, whereby an aggregation of surface geom-

etries can approximate highly irregular and even organic figures. Nonhierarchical meshes can be subjected to specific metrics—by means of Voronoi diagrams or Delaunay triangulations—in order to achieve more regulated surfaces and masses. These techniques are especially important in the development of responsive surfaces.

In these instances, the geometric complexities often prohibit nondigital methods of *three-dimensional modeling*.

The challenge is for parametrics, useful for developing tantalizing formal abstractions, to transcend predictable outputs based on predetermined inputs. A continuous reevalua-

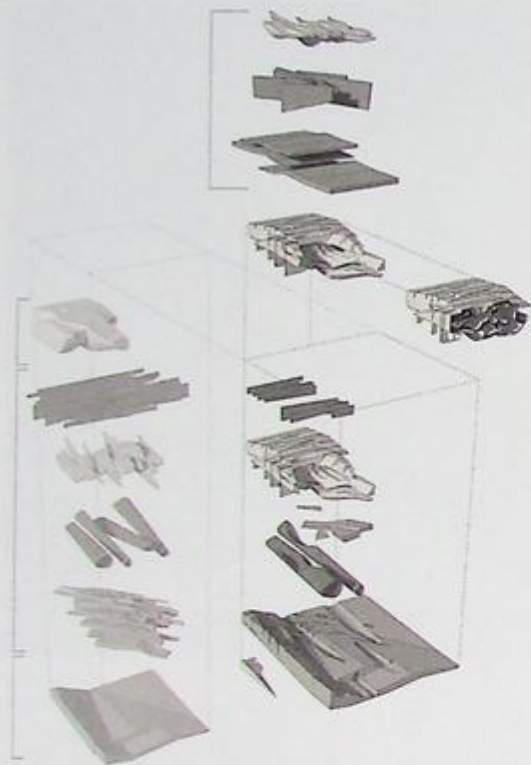

In this project by James Pelleter, a simple repertoire of forms—teardrops, wedges, and tubes—is distorted, multiplied, rescaled, and treated alternately as solids and voids, and then used as the geometric primitives for the simultaneous development of both a complex architecture and the manipulation of its site. Such modeling would be impossible using exclusively analog tools. (Critics: Andrew Batay-Csorba, Thom Mayne, and Val Warke; Cornell University)

tion of the initial and evolving parameters is critical to its instrumentality. And for meshed surfaces, which tend to solidify their “responses” to the designer’s input during the design process, to become actively responsive during the life of a construction.

#### Variability

Genuinely responsive surfaces and objects—those that morphologically alter throughout the life of a structure—are beginning to appear as new materials and techniques are being developed, often through convergent technologies and disciplinary hybridization.

One of the issues facing architecture is the extent to which variation and variability enter the process, and for how long they persist within the work. In biology, a homogeneous system, determined by genetics, is often transformed into a heterogeneous system by its immediate contexts, deforming a predetermined and undifferentiated

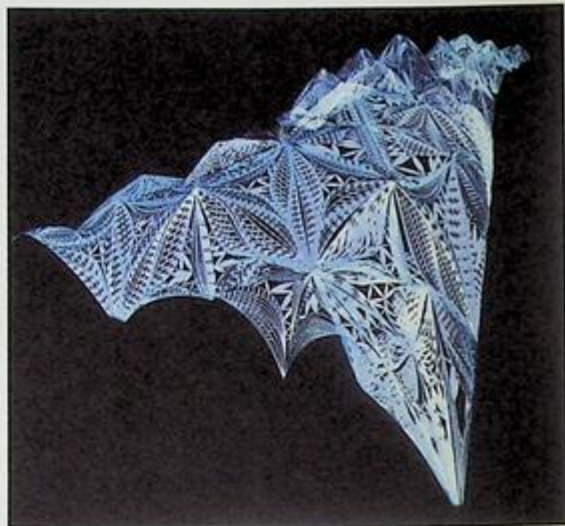

It is often assumed that there is a singular relationship between the geometry of a structure and the materials of its construction. San Francisco-based IwamotoScott Architecture’s

Line Array project (2010) proposes the use of protocell-based materials in the construction of an asymmetrical, highly variable structure with irregular spans, loads, and that even change

from columns to beams and from tensile to compressive. These materials are composed of cells capable of gathering or dispersing at the nanoscale in response to requirements at the macroscale.

organization through constant adaptation. Many architects argue for an architectural version of this biological epistasis in which variation occurs well beyond the onset of a building’s design, even throughout the life of the building. The configurations of spaces might change as the users age, with changes in family dynamics, with altered economic situations, or with seasonal and long-term climatic changes.

Similarly, concepts of *self-organization*—whereby a system finds its own optimized structure, often with very little predictability—seem to more fully duplicate natural human settlement patterns. Self-organization may prove quite valuable at developing large-scale organizations.

#### Networks

Today, there can be a direct, instantaneous connection between design, two-dimensional digital modeling, rendering, and three-

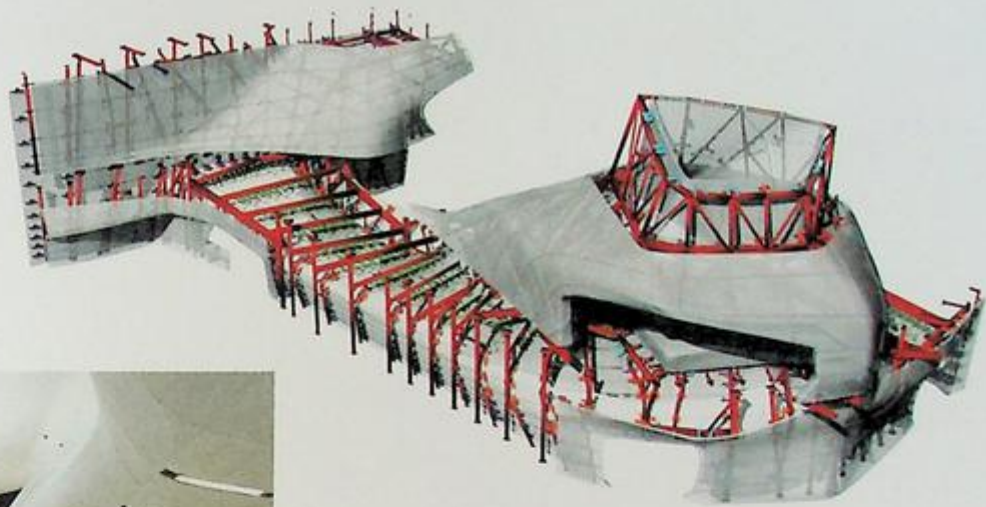

The sinuous geometries of Trahan Architects' Louisiana Sports Hall of Fame Museum in Natchitoches, LA, USA (2011), would have been virtually impossible to construct a decade ago. The close digital collaboration, beginning with the architects' three-dimensional documents, included steel consultants David Kufferman and Method Design, and fabrication and

BIM management company Case, making it possible to carve a path directly from design to fabrication. The interior is shaped by over 1,000 individually cast stone panels supported by an equally individualized steel framework with thirty connection types, all digitally programmed through a combination of ten software packages.

dimensional modeling, so the designer has immediate access to a vast array of representations and viewpoints for exploring the qualities of a design.

It is becoming increasingly necessary for the designer to utilize and combine numerous software systems during each phase of the design process, especially as the information involved in producing the representation of a design can also be used to investigate multiple facets of that design. Digital models can be used to evaluate a work's environmental relationships (such as solar orientation, heat loss or gain, and various comfort criteria), material usages (including types and amounts), contextual aspects (shadows cast, view corridors, public accessibility), and even legal compliance (zoning or other codes).

Additionally, building information modeling (BIM) has become a contemporary version of stereotomy, with digital representations—even during the earliest stages of a design—capable

of being shared among architects, project consultants, fabricators, and contractors, whereby changes made to one element instantly affect changes in related areas.

Graphic programs have fostered an ability to generate forms that are imaginable only through digital processes. As these programs become more available for adaptations and modifications through scripting, designers begin to require a keen knowledge and skepticism of available data sources, with input needing careful ranking and traceable algorithms so that portions of the process can be edited or redirected upon evaluation of the output. Such evaluation will require the development of effective skills and tools. While the digital realm will provide real-time data as a design evolves, the designer will still need to select and prioritize the data, humanize its conclusions, and assess esthetic qualities.

Aspects of fabrication—the equipment, tools, and methods that form and assemble a structure's materials—are essential in defining the character of a finished work.

# 24

## fabrication

**Techniques of fabrication often expand the characteristics of an existing technology that might have originally been intended or limited to a particular, even nonarchitectural application, making material and structural discoveries that were previously untapped.**

Construction methodologies—how a material, a detail, or a building is made—are an important aspect of the design process. Where a knowledge and appreciation for a specific construction method is privileged and subsequently embedded within the conceptual development of a work, the specifics of those methods

The architecture of Ciudad Abierta in Ritoque, Chile, a school that was founded in the 1970s, is a built expression of a participatory process that engages an unstable landscape of sand dunes and wetlands. Architectural concepts are initiated through poetic collective events and happenings, with faculty and students developing these

concepts into houses and academic structures. Here the construction process emphatically does not come from a set of architectural drawings. Instead, it is the result of a continuous and ongoing process—an architectural laboratory for the testing of ideas, materials, and rituals in a continuously evolving environment.

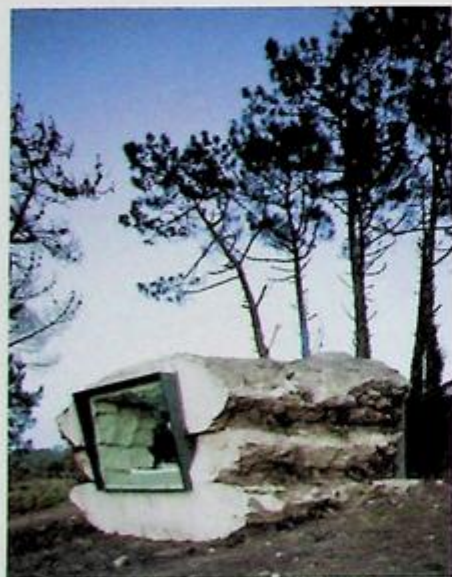

In Laxe, Spain, in 2010, Studio Ensemble constructed the Truffle—a mass of space that emerged from its environment. A hole was dug and subsequently filled with bales of hay, with the existing

earth serving as formwork into which the concrete was poured. As the concrete hardened and the earth was scraped away, the hay was slowly consumed by a cow, revealing the space within.

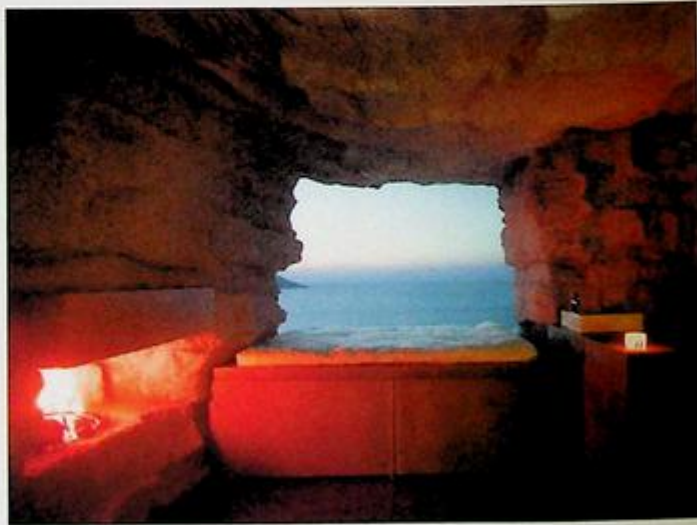



The enclosing wall of Hanil Visitors Center & Guest House in South Korea, completed in 2009 by BCHO Architects with Mark West of CAST, registers the trace of

the fabric-lined formwork that was used to construct it. The concrete takes on a surprising fragility, as if, like a curtain, it is about to sway in the wind.

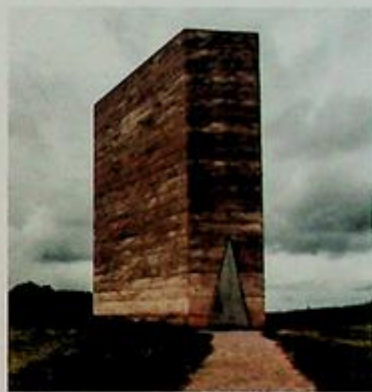

The inner space of the Bruder Klaus Field Chapel by Peter Zumthor in Wachendorf, Germany (2007), was created by burning away the locally forested spruce trees that had been arranged in a

teepee formation upon which the concrete was layered. Their textured residue bears witness to the farmers' use of local materials to construct this modest chapel.

inform the characteristics of the architecture.

For example, the dimensions of plywood panels that compose the formwork of a poured-in-place concrete wall are permanently inscribed, as measure and as texture, onto the surfaces of the wall that they have formed. The plug holes that served to distance the plywood surfaces into which the concrete is poured, and that are either left open or subsequently plugged, provide yet another clue as to its process of coming into being, adding another scale of measure and texture to its surfaces. Similarly, a wall might be constructed of a series of individual metal components where the potential for incremental geometric mutation and variation is inherent to the wall's fabrication. The computational and fabrication systems necessary to both conceive of and manufacture each component are traced within the wall's scalelike surfaces as well as its responsive geometries.

## CRAFT

The act of building can be understood as the result of a process, one that through a series of steps produces the finished work. While drawings typically serve as the instruction manual for the construction process and operate as intermediaries between the designer and the finished work, the equipment, tools, and methods that form and assemble the materials are essential to the characteristics of the finished work. The characteristics—physical, cultural, and economic—of the site in which the work is constructed and the methodologies of local building practices can provide a unique specificity that clearly situates a work within a particular context.

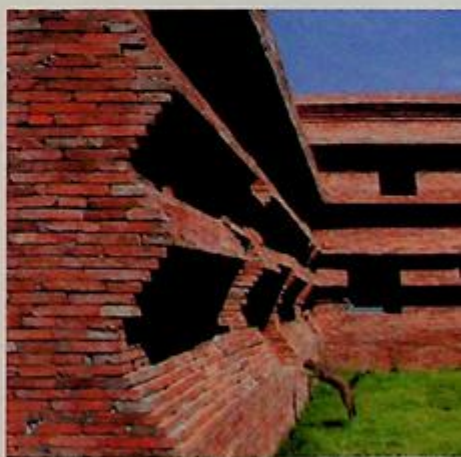

The walls of the 2011-13 Kantana Film and Animation Institute, designed by Boonserm Premthada of Bangkok Project Studio in Nakhon Prathom Province in Thailand are built of bricks handmade from the

surrounding paddy fields. The stepping of each brick transforms the massive wall into an undulating curtain full of light and shadow, punctuated by openings that reveal its thickness and mass.



Beginning with an abstracted doric column, Michael Hansmeyer's *Sixth Order* installation at the 2011 Gwangju (South Korea) Design Biennale explores a subdivision process where inherent formal charac-

teristics are individually tagged and then assigned specific behavioral parameters. The result generates an ornamental system of endless variation and complexity, yet one that retains a sense of overall order.

## DIGITAL FABRICATION

Digital fabrication generates form directly from computer drawings, enabling increasingly complex forms to be constructed. Designs and details are developed using specific computer software that is compatible with various types of fabrication machinery. These drawings are then transmitted to machines that subsequently fabricate the forms. This fabrication can occur at multiple scales and with extremely precise detail and dimensional tolerances.

Furthermore, while industrialization introduced an efficiency that depended on the repetition of both assembly and fabrication, the development of computational design and fabrication processes brings an equal efficiency to the mass production of differentiated elements, where standardization is no longer necessary for either material or economic optimization.

And not all fabrication processes are initiated within architecture. Techniques of fabrication often expand the characteristics of an existing technology that might have initially been intended or limited to a particular (and perhaps nonarchitectural) application, making material and structural discoveries that were previously untapped. While the technology remains embedded within the work, these technological "misuses" can often produce surprising results that expand an existing technology's potential.

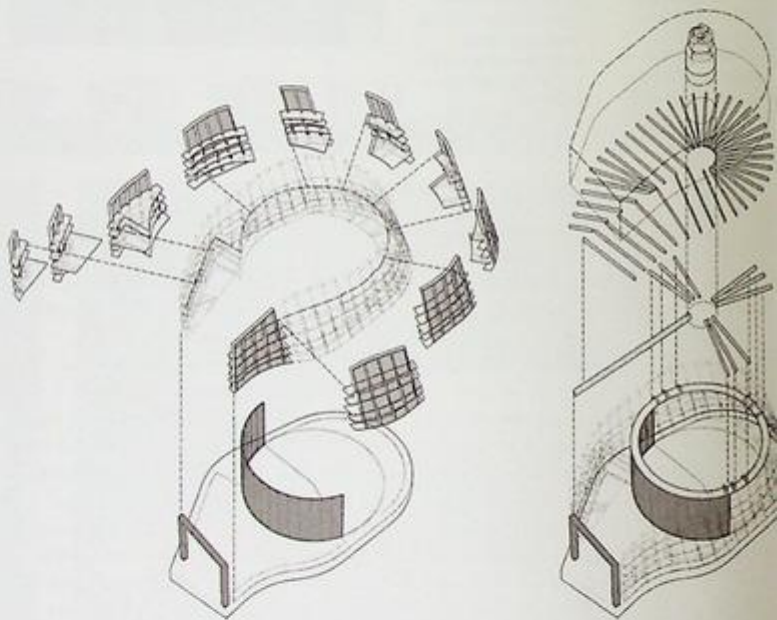

SHoP Architects' *Camera Obscura*, completed in Greenport, NY, in 2005, is an early example of a project constructed entirely from digitally fabricated components. Each material

system—whether it be the wood cladding or the metal panels or the steel connector plates—necessitated a unique fabrication technology, which was then subsequently assembled on site.

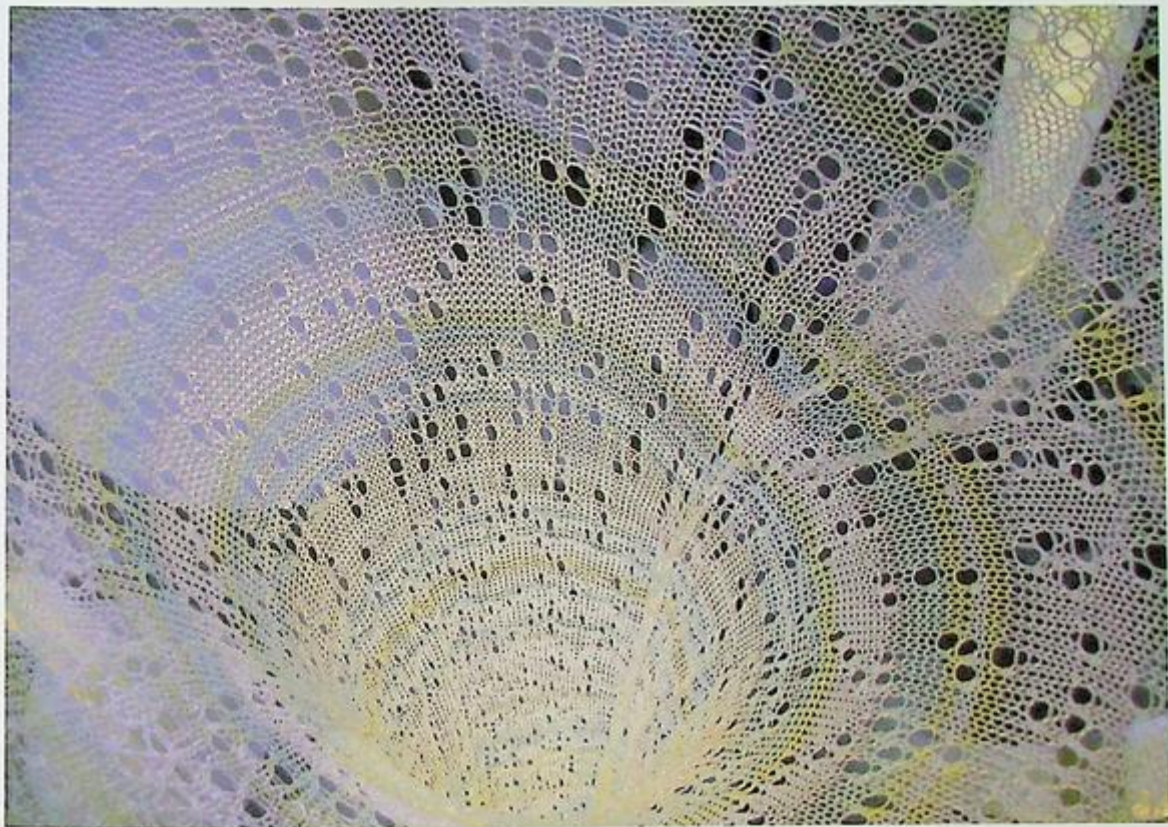

Jenny Sabin's *myThread* pavilion, exhibited in 2012 at the Nike Stadium in New York City, deploys textile-based technologies to weave reactive and photoluminescent threads into a gauzelike fabric. A skeleton of aluminum rings stretches the fabric into spatial tubes that

weave the pavilion into the surrounding space. The scale at which the textile is deployed, along with its reactive capabilities, introduces new and surprising characteristics to a familiar technology—this is no longer a sweater.

An architecture of prefabrication is often conceived as a mobile architecture, one that can either be moved or reassembled, or one that touches lightly on the land, minimally disturbing the context to which it has been brought.

# 25

## prefabrication

**Prefabrication often begins with a specific set of performance criteria that leads to an idealized solution.**

As a boat is fabricated in a shop and then introduced to water, a prefabricated architecture is simultaneously *site-less* and *site-ed*. It is constructed away from its site and subsequently brought to its site, either as an entire module or as a kit of parts that can be assembled upon arrival. It is often made of standardized parts or modules



Studio Ensemble's 2007 Music Tower for Berklee School of Music in Valencia, Spain, proposes a system of prestressed concrete beams, of the scale and profile more typically associated with infrastructural projects (such as bridges and overpasses).

The beams are brought to the site and stacked into place, producing a dense structural skin that both supports its interior floors and allows for cantilevers that create enormous voids of suspended exterior piazzas.



John Entenza, the editor of *Arts and Architecture*, wrote in the 1945 announcement of the magazine's case study house program, "The house must be capable of

duplication and in no sense be an individual performer." Pierre Koonig's 1959-60 Case Study House #22 is an example of a project that, while designed for a very

specific site, was constructed of standardized steel and glass components that could be recombined and deployed on a very different—and less extreme—site.

that can be repeatedly (mass-) produced or it can appropriate existing already-made components that have not necessarily been fabricated explicitly for architecture. A prefabricated architecture is one that is often conceived as a mobile architecture, one that can either be moved or reassembled, or one that touches lightly on the land, minimally disturbing the context to which it has been brought. Technological experimentation and ease of assembly are often motivated by a site's remoteness or difficulty of access, a need to quickly expedite shelter in a time of crisis, or the ability to incrementally expand over time through accretion of additional modules or assemblies.

### Standardization

In his foreword to the 2008 MoMA exhibition catalog *Home Delivery: Fabricating the Modern Dwelling* (page 7), museum director Glenn Lowry writes that "mass customization [will] trump mass standardization." And while, certainly, there is a paradigm shift under way concerning the definition of standardization in light of emerging digital technologies, where the production of identical parts is no longer a prerequisite for the efficiencies typically associated with standardization, *optimization* (as defined by the speed of production, minimum waste, and reproducibility) remains one of its most identifiable characteristics.

The scale of "standardized" components can range from a brick, a plywood panel, a 2-inch x 4-inch (5 x 10 cm) wood stud or a steel beam, to a room or even an entire building. All depend on repetition, expansion or aggregation to construct something larger than itself. It is a unit of measure that is embedded in the material (or space, or process) that not only facilitates duplication but also brings a form of logic to the constructive process.



Prefabricated 1.00 m (f) x 0.20 m (h) x 0.28 m (w) (1.09 yd x 8 in x 11 in) concrete troughs are stacked bearing and space-defining walls of the 2004 Casa Pentimento in La Morita, Quito, Ecuador. The archi-

itects Jose Maria Saez and David Barragan conceived a universal system where each prefabricated module can serve alternately as planter, storage unit, or bookshelf, while wooden planks slipped between each course serve as stair, table, or chair.

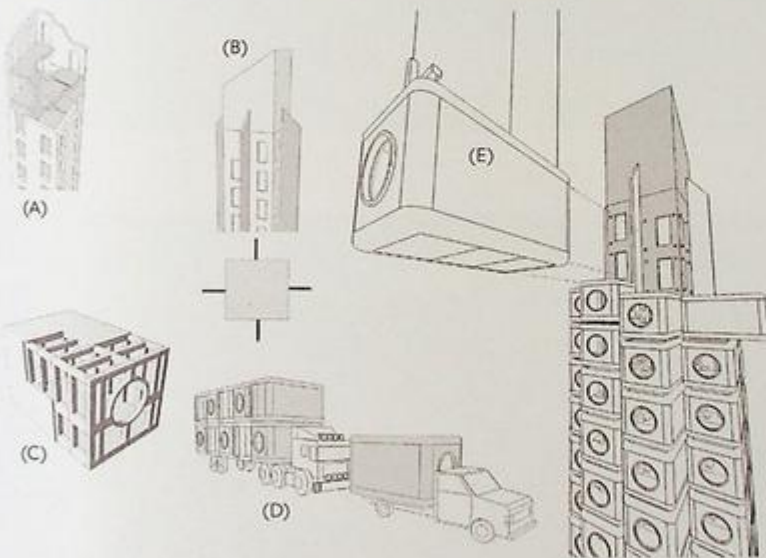

The Nakagin Capsule Tower in Tokyo, Japan, designed in 1972 by Kisho Kurokawa consists of 140 individual living capsules cantilevered from two concrete cores. While these cores are built on-site and contain the building's main infrastruc-

tural elements (stairs, elevators, utilities, and so on), the ~100 square-foot (30 sq m) steel modules are fabricated off-site and individually bolted to the concrete core—they were designed to be replaced every twenty-five years.

The elevator shafts were surrounded by a reinforced concrete spiral staircase, enclosed in the lift-formed concrete stair shaft. These stairs were usable throughout the construction process (A).

The service risers were, in fact, exterior fins on the lift shafts, eventually concealed by the attached capsules (B).

The capsules were prefabricated in a shipping container factory. They are welded, lightweight, steel truss boxes clad with galvanized ribbed

steel panels, rust-preventative paint, and a weatherproof plastic with an estimated twenty-year life span (C).

Large trucks transported the capsules 280 miles from the assembly plant to the outskirts of Tokyo where they were individually loaded onto smaller trucks (D).

The capsules were lifted by crane and bolted to the lift core with four high-tension bolts, and all were attached within thirty days (E).

### Sitelessness

Prefabrication often begins with a specific set of performance criteria that leads to an idealized solution. While usually developed independent of a specific physical site, the manner in which a prefabricated project is transported to a site, the way in which the work is eventually situated on a site, and how it might engage a site's environmental and programmatic factors can have an enormous impact on the initial design parameters. This expanded context for a prefabricated work suggest that there be a certain adaptability built into the work, that it have embedded within it the potential for local modification (legs that adjust, panels that operate) or incorporate adaptive components that allow for an eventual expansion through the addition of additional bays or components. A prefabricated architecture is often entirely independent of site but, necessarily, deeply adaptive to it.



Albert Frey and A. Lawrence Kocher's 1931 Allied and Arts Industries exhibition house *Aluminaire* was entirely manufactured from existing new materials. Here, form was developed independent of site, with lights that simulated daylight recessed into ceilings and projected

from window frames. Innovative building materials and construction technologies were used to propose an affordable architecture that could be produced in a factory setting and subsequently erected on any site in only ten days.



Difficult access to this remote Icelandic site necessitated that the 1999 construction of this summerhouse, by Óli Mathiesen of Gláma Kim Architects, occur off site. The dimension of the transporting truck and the weight of the overall structure were critical

parameters of the design process. Using standardized materials of corrugated metal (recalling the Icelandic houses of the early twentieth century) and an interior lining of plywood panels, it is through its precise dimensions that it has the ability to bring measure and scale to its endless landscape.



Shipping containers are transformed into occupiable space through Spillman Echle Architekten's 2006 design for Freitag's Zurich showroom. Units that were designed according to a distinct set of dimensional and material parameters are now reused in an entirely new context, where high fashion now rubs up against industrial grit and demonstrates both the company and architect's commitments to sustainability and recycling.



Yona Friedman's (Untitled) Bridge proposes a spatial infrastructure that has the ability to undergo infinite incremental change through the multiplication and densification of the basic component units that populate its megastructure.

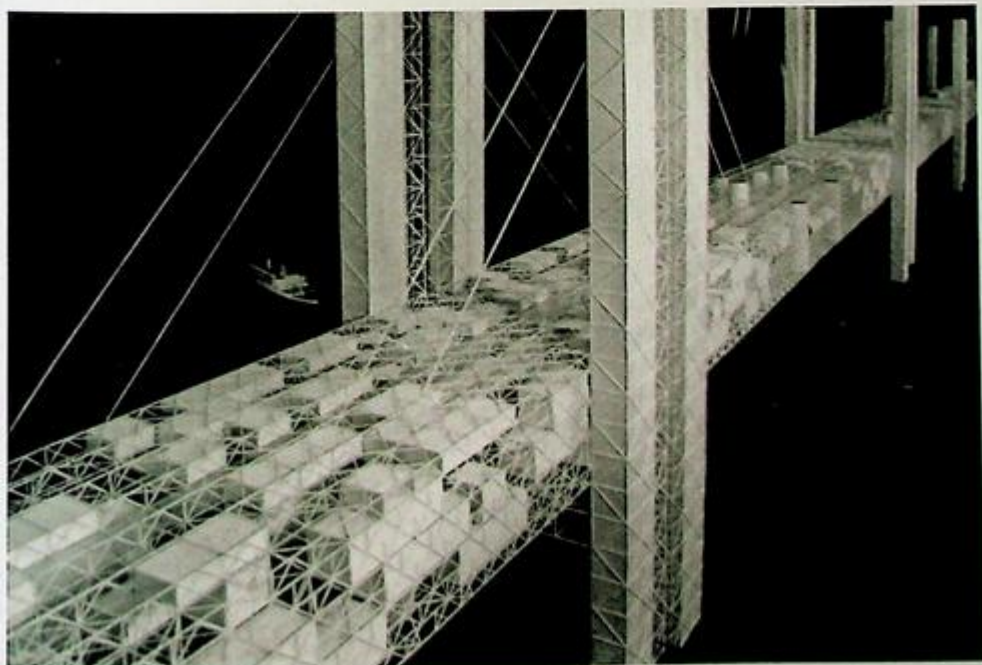

### Sitelessness

Prefabrication often begins with a specific set of performance criteria that leads to an idealized solution. While usually developed independent of a specific physical site, the manner in which a prefabricated project is transported to a site, the way in which the work is eventually situated on a site, and how it might engage a site's environmental and programmatic factors can have an enormous impact on the initial design parameters. This expanded context for a prefabricated work suggest that there be a certain adaptability built into the work, that it have embedded within it the potential for local modification (legs that adjust, panels that operate) or incorporate adaptive components that allow for an eventual expansion through the addition of additional bays or components. A prefabricated architecture is often entirely independent of site but, necessarily, deeply adaptive to it.



Albert Frey and A. Lawrence Kocher's 1931 Allied and Arts Industries exhibition house *Aluminaire* was entirely manufactured from existing new materials. Here, form was developed independent of site, with lights that simulated daylight recessed into ceilings and projected

from window frames. Innovative building materials and construction technologies were used to propose an affordable architecture that could be produced in a factory setting and subsequently erected on any site in only ten days.



Difficult access to this remote Icelandic site necessitated that the 1999 construction of this summerhouse, by Óli Mathiesen of Glama Kim Architects, occur off site. The dimension of the transporting truck and the weight of the overall structure were critical

parameters of the design process. Using standardized materials of corrugated metal (recalling the Icelandic houses of the early twentieth century) and an interior lining of plywood panels, it is through its precise dimensions that it has the ability to bring measure and scale to its endless landscape.





Shipping containers are transformed into occupable space through Spillman Echle Architekten's 2006 design for Freitag's Zurich showroom. Units that were designed according to a distinct set of dimensional and material parameters are now reused in an entirely new context, where high fashion now rubs up against industrial grit and demonstrates both the company and architect's commitments to sustainability and recycling.

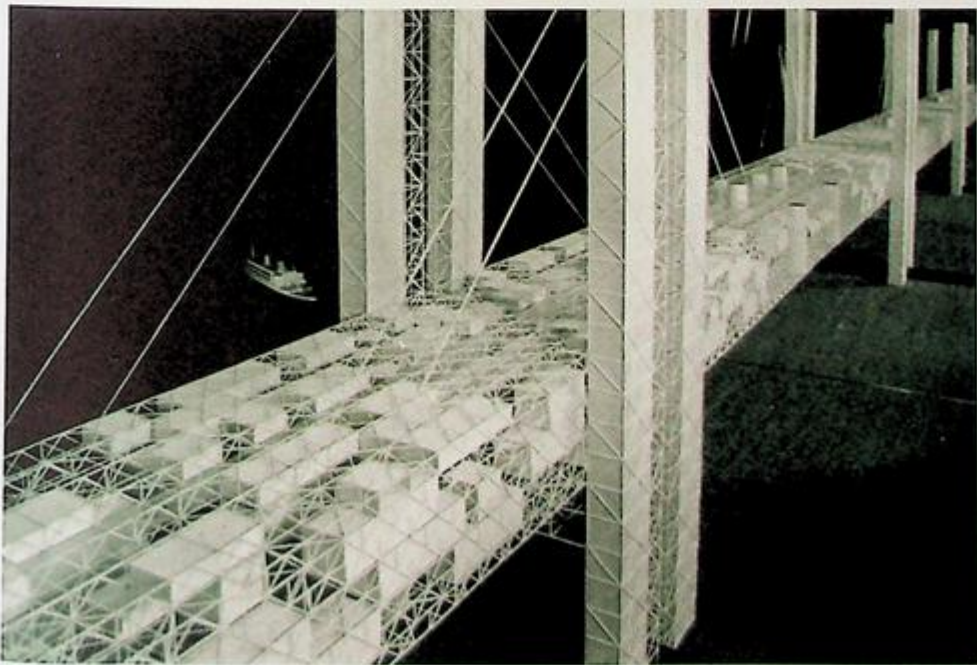

Yona Friedman's (Untitled) Bridge proposes a spatial infrastructure that has the ability to undergo infinite incremental change through the multiplication and densification of the basic component units that populate its megastructure.

Presentation drawings are intended to stand in for the form and the experience of an eventual, constructed work.

# 26

## presentation

**A presentation will amplify the most important readings of a work, directed toward a specific audience.**

The presentation drawing or model represents the conclusion of a particular phase of a design process. Once the design process is complete, a presentation drawing or model does not serve as a set of instructions to construct the work but, instead, as a device that embodies and communicates the most important ideas,

BIG's (Bjarke Ingels Group) 2011 competition presentation drawing for Europa City, a new commercial center near Paris, France, realistically and emphatically presents the underlying concept of the work: the fusing together of

urban block and topographic landscape into an enormous earthwork that collects retail, cultural, and recreational programs—a modern medieval city presented from above within the context in which it is located.



Frank Lloyd Wright's 1936 colored-pencil and pastel perspective of Edgar J. Kaufmann's house, Falling Water in Mill Run, Pennsylvania, gives us a very real sense of the final work. The use of perspective

looking up from the falls reinforces the primary understanding of the house both as an extension of its rural landscape and as a series of Cartesian planes superimposed and hovering above it.



Hugh Ferriss's delineations advertised the buildings to the consumers for whom they were intended. This 1929 moody nighttime image of the Chanin Building in New York City designed by Sloan & Robertson was a real estate marketing tool. A silhouette

that emphasized the building's mass, light, and shadow with very little attention to detail, the drawing intentionally presents a building full of mystery, waiting to be inhabited—the luminous star emerging from the city below.

the critical characteristics, of the work. And while it often documents a work whose intention is to be materialized, it can also present a body of speculative ideas—in other words, it can be an end in and of itself.

#### Audience

A presentation takes into consideration its audience or the context within which the presentation will be read and understood. An architectural competition jury is distinct from a fund-raiser, which is distinct from a client presentation, which is distinct from a museum exhibition. Each forum has unique criteria through which the work will be considered, criteria through which the architectural concept must be framed. The presentation will inevitably amplify

a particular reading of the work that is most important to be communicated to a particular audience.

#### Documentary

Presentation drawings and models can be documentary and serve to explain, to demonstrate, the project. They are intended to stand in for the form and the experience of an eventual, constructed work. For example, a perspective might demonstrate to a client the experience of what it's like to occupy the building or what will be seen through the architectural lens of the building's skin. Or a site model might show the building's mass and scale in the context of its surrounding context—how tall or how bulky it is in relation to its neighbors.

(continued on page 213)

# The Projections of Zaha Hadid

In a strict reading of the terms, *presentation* conveys ideas that may have not yet been materialized but that are conceptually determined. In contrast, *representations* denote the “presenting again” of an idea that may already exist in another medium such as photography or life drawing, or the progression of an idea that is in the process of coming into being.

Architectural drawings, images, and models are presentations of constructions prior to their being built. Photorealistic renderings seek to collapse presentation into reality, masking the unsettling gap between. Alternatively, architects can exploit the power of architectural presentations by heightening the distinctions between realism and presentation, destabilizing expectations and understandings of the world to come. Within the discourse, most architectural presentations privilege not the construction yet to come but the conceptual framework and ideas that have informed the design process. Their role is often to seduce the audience into a specific understanding of the work.

Zaha Hadid's work explores the immense power of architectural images to be both presentations of a new world to come as well as the visual documentation of the theoretical structure of *images understood as representations of ideas*. Hadid built her reputation as an architect by dispensing with the obligation to present architecture according to rules of construction, choosing instead to construct striking and unexpected presentations of her projects as *she would have us see them*. In her drawings for the Peak, a 1981 competition for a social club high above Hong Kong, Zaha Hadid demonstrated a project that lacked any overt concern for tectonics, gravity, structure, enclosure, or façade, organized instead by the underlying rules of the presentation



Zaha Hadid: The Peak Leisure Club, Hong Kong, 1982-83



Zaha Hadid: Cardiff Bay Opera House, Wales, UK 1994-96

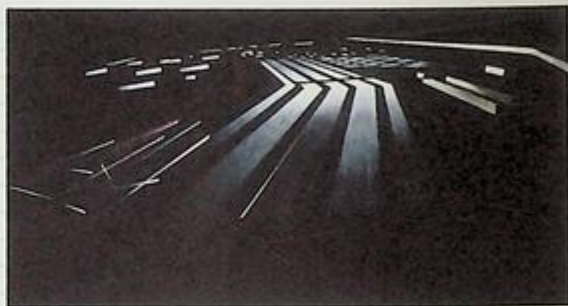

Zaha Hadid: Hoenheim-Nord Terminus and Car Park, Strasbourg, France, 1998-2001

technique deployed—perspectival drawing and oblique projection. The Peak and Hong Kong were cast in representational capitulation with the logic of her design, as if the city would be entirely remade through the lens of the competition presentation.

Zaha Hadid's presentation drawings and models become complicit in the exploration of their architectural ideas. Her work is not simply *illustrated* through perspective, but it is spatially *transformed* by perspectival presentation, conflating the design with its presentation. By pursuing the explorative potential of presentation over the tectonics of building, Zaha Hadid's work has often

opened up an unsettling gap, exemplified early in her career by the controversy over the Cardiff Bay Opera House: Her winning presentation was never built, doomed by misperceptions regarding the capacity of the drawings and images to be realized.

These early paintings and drawings prefigured her future built works. While the Vitra Fire Station and IBA Housing demonstrate the constructive ambitions of her early perspectival drawings, the Hoenheim-Nord Terminus and Car Park convincingly merge presentation with the final project. Oblique angles of the building solidify in concrete the explorations of drawings, while the

entire parking surface is rendered as a large canvas, presenting the systems of the transportation hub to the user. In Zaha Hadid's recent work, the development of digital technologies has enabled the visualization and subsequent construction of complex spatial conditions. Yet, as presentation succumbs to the seduction of photorealism, it paradoxically erases the tension once held in her earlier presentations: that of a didactic tool for imagining what we are about to experience.

—David J. Lewis (*LTL Architects; Parsons, the New School for Design*)



Alexander Brodsky and Ilya Utkin's 1987 competition-entry drawing, entitled *Bridge over a Precipice in the High Mountains*, constructs a magical glass chapel impossibly teetering on the

brink of the abyss. Here, the drawing operates as simultaneous metaphor and critique of a relentlessly banal state of contemporary architectural production and thought in Russia.

### Evocative

A presentation can be more conceptual and suggest an intention of a potential work, an evocative image that envisions a future world or what architecture could possibly be. In the hands of architects like Giovanni Battista Piranesi or Lebbeus Woods, these drawings and models can take the form of an architectural manifesto—a speculative position that encourages debate and often critiques the contemporary views on architecture and the city, imagining a world free of the material, structural, and political conventions with which architecture is bound. Their strength often lies in their ambiguity and their ability to suggest rather than explain.

### Media

The media of presentation serves to reinforce the architectural concept. While collaged material will often carry with it the meanings and textures embedded in the fragments that are appropriated into the collage, it is the process of overlaying multiple "voices" in the presentation (styles, materials, and scales) that can reinforce an architectural dialogue fundamental to the concept being presented. Video animations or "walk-throughs" place the audience within the work but can also present a temporal experience that was critical to the development of the architectural idea. While computer-generated images can introduce an uncanny reality, they can demonstrate with great precision and detail the responsive and often environmentally interactive dimension that informs the final forms and geometries.



Alexander Brodsky and Ilya Utkin's 1987 competition-entry drawing, entitled *Bridge over a Precipice in the High Mountains*, constructs a magical glass chapel impossibly teetering on the

contemporary society. The collages that they produced to envision this new world were populated with people imported from contemporary and popular magazines. Ron Herron's *Tuned Suburb* collage, produced for the 1968 Milan Biennale, proposed a "Poplar Pak" of imported

technologies that might invigorate a banal suburban landscape. The convincingly invented "existing" suburb is populated with background drawings of amusement park structures and foregrounded with collaged figures of everyday life.



Superstudio's 1969 photomontage "The Continuous Monument: An Architectural Model for Total Urbanization" begins with a photograph on which a drawing is subsequently overlaid. The shift in both technique and scale

reinforces a visionary scenario of a distinct world defined by its monumental scale and abstracted vocabulary, one that proposes a future order superimposed over a messy and obsolete past.

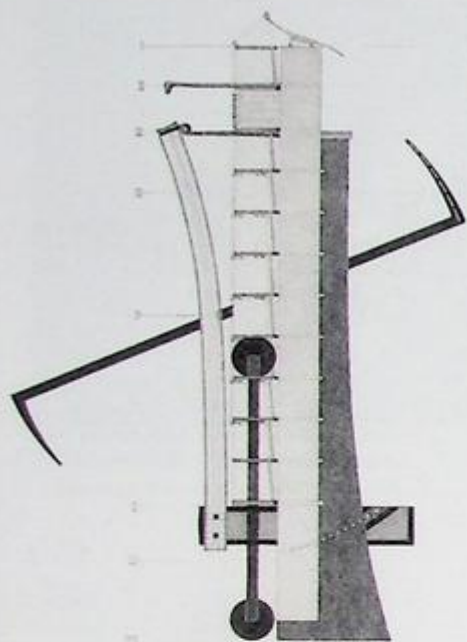

The Telamon Cupboard of Ben Nicholson's 1986-1990 Appliance House exaggerates the prosaic repository for everyday detritus into an (only partially) accessible domestic instrument. The

precise pencil drawings demonstrate the cabinet's structure, hinges, knobs, mechanisms, and operations, while the collages suggest the materialistic density for which they are intended.

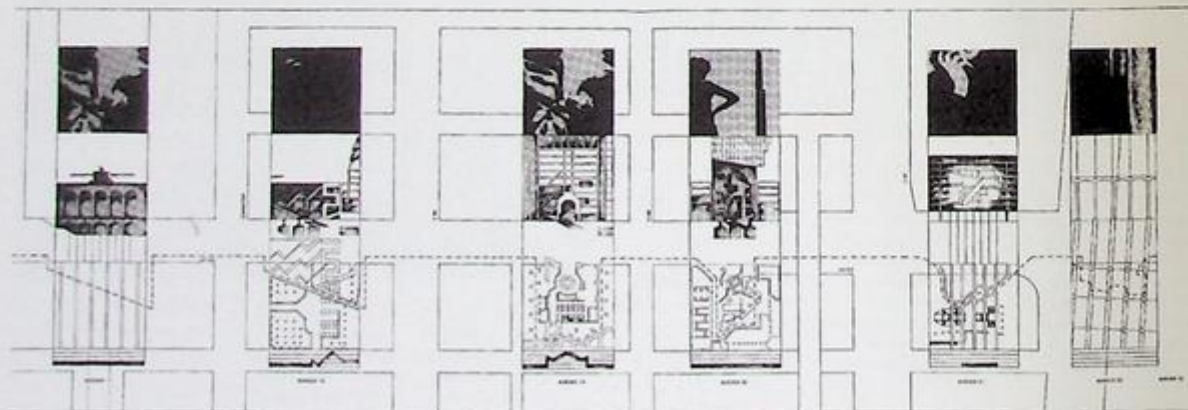
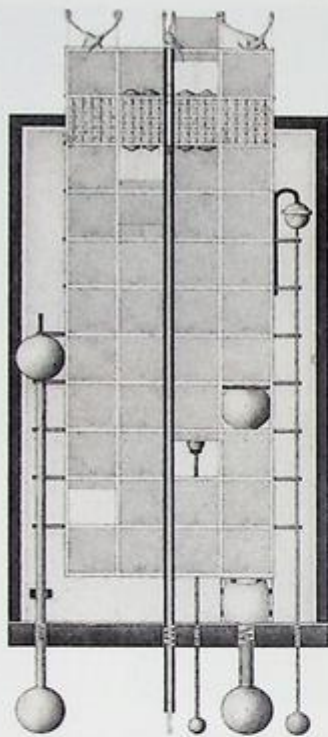

Buildings and cities are intrinsically static, bound by material and by gravity. Yet the drawings of Bernard Tschumi's 1976-81 Manhattan Transcript project present an

alternative view, a city of relationships between spaces and their use, between form and program. The drawings leave behind more singular representations of space and

urban form and instead borrow freely from filmic conventions such as the jump cut, the montage, and the splice. Here, photographs, architectural drawings, and

motion diagrams, together, construct urban storyboards that fuse the physical with the ephemeral, the permanent with the fleeting.



C. J. Lim's collage drawings construct visual narratives—dreamlike landscapes that intertwine the real and the fictional through hybridized drawings and models. In his proposal for a Sky Transport for London, he pays homage to the cartoonist Heath Robinson's "crazy contraptions." Here, he lifts and transforms London's

underground transportation system into a floating infrastructural network—a "sky-river" for both commuters and recreational enthusiasts alike. Ink drawings serve as context for pop-up paper models that reinforce the dialogue between the real and the imagined, the familiar and the strange. Battersea, London, UK, 2007

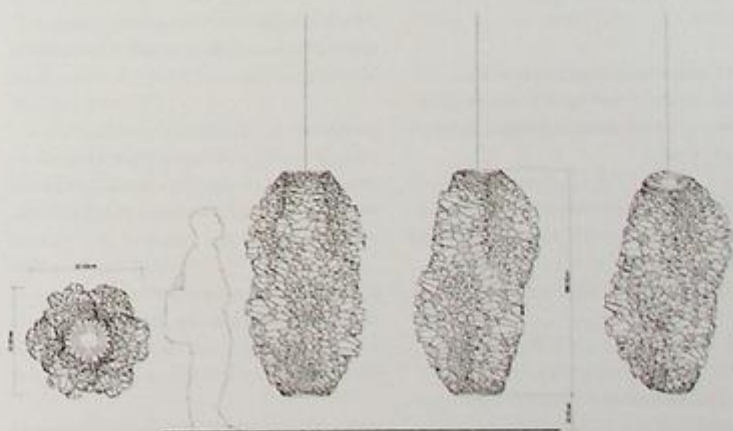

Andrew Kudless's drawings for his 2012 Chrysalis III structure required the use of particular computer software to generate a complex barnaclelike surface of unique shapes. The undulating

surface of 1,000 digital cells is suspended from an underlying body, with each cell competing for spatial real estate as they compress and expand three dimensionally into their final state.

# Glossary

**abstraction** a translation that condenses a complex form or concept to a fundamental figure or principle

**anamorphic** distorted when viewed from most positions, but normalized when seen from a specific point of view

**axis** an imaginary line that connects a range or sequence of spaces or objects.

**axonometric** a constructed drawing on the oblique in which a plan view is kept undistorted, and vertical surfaces are projected upward or downward.

**brise soleil** a "sun-breaker," is a device—usually appended to a structure—intended to control the penetration of sunlight.

**chiaroscuro** the relationship between light and dark, generally established through contrast

**context** the situations—formal, temporal, climatic, and so on—in which a building finds itself, and that will inevitably affect its perception

**cornice** a horizontal projection, often emphasizing the top of a building, the upper boundary of a segment of a façade, or the ceiling of a room

**defamiliarization** the process of construing something that is normally very familiar to be something unfamiliar in order to promote new observations or fresh understandings

**dialogical** participating in a discursive exchange, whereby meaning is expanded, exchanged, and renewed through the engagement of one or more other voices or artifacts; the opposite of monological, in which only a single voice can be perceived

**eclecticism** the deliberate combination or merging of various styles, expressions, or doctrines

**elevation** an architectural drawing that provides the measured documentation of one side or flank of a structure, with no perspective distortion

**enfilade** a series of spaces connected along an axis or line, generally through a range of doorways

**façade** a building's face, it is a structure's most public visage; buildings can have more than one façade, especially if they front on multiple venues.

**familiarization** a process whereby something that is unknown is represented in terms of one or more things that are known

**loggia** an open, exterior gallery, usually at ground level, through which people might circulate

**membrane** a thin structure or layer that separates two conditions of differing spatial characteristics, functions, temperatures, and humidity

**mimetic** exhibiting a characteristic that resembles in some manner the characteristic of another entity

**perspective** a simulated three-dimensional view, generally constructed from a specific vantage point along a horizon, with one or more vanishing points toward which surfaces appear to converge

**pilaster** a rectilinear suggestion of a column, usually emerging from the surface of a wall; occasionally used to refer to a half column, which is semicircular in plan as it engages a wall

**plan** an architectural drawing that represents the parts of a building, a complex of buildings, or a city, looking downward from a horizontal slice generally taken at eye level (in building plans) or from an indefinite position above a city or complex

**poché** the less consequential aspects of a building or city that usually serve as background or supportive material for the more significant aspects of the building or city

**precedent** something that has come before and that is evoked in the production of something new

**rusticated** a surface (often at the base of a building) composed of large masonry blocks with a rugged texture and rough joinery; or alluding to such a surface

**section** an architectural drawing that reveals what can be understood when an imaginary vertical slice is taken through a building, garden, or city, usually suggesting the vertical relationship of spaces

**scale** a relationship of size between one entity and another; in architecture, human scale refers to the relationship between a body's dimensions and range of motions and the architecture designed to specifically accommodate these dimensions

**site** the physical location in which a building is to be located, possibly including those nearby features that shape its views, approach, and configuration

**space** a definable volume of emptiness that can be occupied, or that otherwise establishes the range across which an observer perceives enclosure

**trope** an aspect of language in which something is used to stand in for something else with which it has some association

**void** an indefinite emptiness

# Bibliography

Sources in **bold** are recommended as general introductions to architecture. Numbers in brackets [ ] indicate chapters to which the texts refer.

- Addington, Michelle, and Daniel L. Schodek. *Smart Materials and New Technologies for the Architecture and Design Professions*. Oxford: Architectural, 2005. [10]
- Cook, Peter. *Drawing: The Motive Force of Architecture (Architectural Design Primer)*. Chichester, England: John Wiley & Sons, 2008. [3]
- Doxiadēs, Kōnstantinos Apostolou. *Architectural Space in Ancient Greece*. Cambridge, MA: MIT Press, 1972. [11]
- Evans, Robin. *The Projective Cast: Architecture and Its Three Geometries*. Cambridge, MA: MIT, 1995. [23]
- Forster, Kurt W. "Schinkel's Panoramic Planning of Central Berlin." *Modulus 16*. Charlottesville: University of Virginia, 1983. 62-77. [11]
- Giedion, S. *Space, Time, and Architecture: the Growth of a New Tradition*. Cambridge: Harvard UP, 1954. [11]
- Goethe, Johann Wolfgang von. *Goethe's Theory of Colours: Translated from the German*. Trans. Charles Lock. Eastlake. London: Murray, 1840. [13]
- Hejduk, John, with Kim Shkapich (editor). *Mask of Medusa: Works, 1947-1983*. New York: Rizzoli, 1985. [20]
- Herzog, Jacques. "Conversation Between Jacques Herzog and Theodora Vischer." Gerhard Mack. *Herzog & De Meuron 1978-1988*. Basel: Birkhäuser, 1997. [10]
- Holl, Steven. *The Chapel of St. Ignatius*. introduction by Gerald T. Cobb. New York: Princeton Architectural Press, 1999. [13]
- Kahn, Louis I. *Louis Kahn: Essential Texts*. Ed. Robert C. Twombly. New York: WW. Norton, 2003. [21]
- Kepes, Gyorgy. *Language of Vision: With Introductory Essays by S. Giedion and S.I. Hayakawa*. Chicago: P. Theobald, 1944. [11]
- Le Corbusier, Jean-Louis Cohen (introduction), and John Goodman (translation). *Toward an Architecture*. Los Angeles, CA: Getty Research Institute, 2007. [3]
- Lobell, John. *Between Silence and Light: Spirit in the Architecture of Louis I. Kahn*. Boulder: Shambhala, 1979. [13]
- Mohsen Mostafavi and David Leatherbarrow. *On Weathering*. Cambridge: MIT Press, 1993. [9]
- Moos, Stanislaus von. *Le Corbusier, Elements of a Synthesis*. Cambridge, MA: MIT Press, 1979. [13]
- Norberg-Schulz, Christian. *Existence, Space, & Architecture*. New York: Praeger, 1971. [11]
- Otto, Frei. *Occupying and Connecting: Thoughts on Territories and Spheres of Influence with Particular Reference to Human Settlement*. Ed. Berthold Burkhardt. Stuttgart: Edition Axel Menges, 2009. [23]
- Pérez-Gómez, Alberto. "The Space of Architecture: Meaning As Presence and Representation." *Questions of Perception: Phenomenology of Architecture*. San Francisco, CA: William Stout, 2006. [11]
- Pevsner, Nikolaus. *An Outline of European Architecture*. Baltimore: Penguin Books, 1960.** [Introduction]
- Ramsey, Charles G., and Harold R. Sleeper. *Architectural Graphic Standards*. Hoboken, NJ: John Wiley & Sons, 2007. [4]
- Rasmussen, Steen Eiler. *Experiencing Architecture*. Cambridge, MA: MIT Press, 1962.**
- Rowe, Colin, and Robert Slutzky, commentary by Bernhard Hoesli. *Transparency*. Basel: Birkhäuser Verlag, 1997. [11]
- Rüegg, Arthur. *Le Corbusier—Polychromie architecturale*. Basel: Birkhäuser Architecture, 2002. [13]
- Samuel, Flora. *Le Corbusier and the Architectural Promenade*. Basel: Birkhäuser, 2010. [14]
- Sandaker, Bjorn N., Arne P. Eggen, and Mark R. Cruvellier. *The Structural Basis of Architecture*. 2nd ed. Hoboken: Taylor and Francis, 2013. [8]
- Sherwood, Roger. *Principles of Visual Organization*. Philadelphia: M.C. De Shong, 1972.** A later version is also occasionally available: *Principles and Elements of Architecture*. Los Angeles: School of Architecture, University of Southern California, 1981.
- Shklovsky, Viktor. *Theory of Prose*. Trans. Benjamin Sher. Elmwood Park, IL, USA: Dalkey Archive, 1990. [17]
- Soltan, Jerzy. "Architecture 1967-1974." *Studio Works 5*. New York: Princeton Architectural Press, 1998. [4]
- Straaten, Evert van, and Theo van Doesburg. *Theo van Doesburg: Painter and Architect*. The Hague: SDU, 1988. [13]
- Summerson, John. *The Classical Language of Architecture*. Cambridge: M.I.T. Press, 1963. [Introduction]
- Thompson, D'Arcy Wentworth. *On Growth and Form*. Ed. John Tyler Bonner. Cambridge: Cambridge UP, 1961. [23]
- Todorov, Tzvetan. *Mikhail Bakhtin: The Dialogical Principle*. Minneapolis: University of Minnesota, 1984. [15, 17]
- Zevi, Bruno. *Architecture as Space: How to Look at Architecture*. Trans. Milton Gendel. New York: Horizon, 1974. [11]

# Contributor Directory

3Gatti  
3gatti.com  
131 (bottom, left & right)

David Adjaye Associates  
adjaye.com  
97 (top, left & right)

Alejandro Aravena Arquitecto  
alejandraravena.com  
70 (middle, right); 163

Allied Works Architecture  
alliedworks.com  
25 (bottom, left & right)

Amateur Architecture Studio  
chinese-architects.com/amateur  
66 (top)

Anathenaeum of Philadelphia  
philaathenaeum.org, 184 (top)

Archigram  
archigram.net, 213 (bottom, left)

Architekturbüro Ernst Gisellbrecht  
gisellbrecht.at  
152 (top & middle, left & right & bottom, right)

Archivo Histórico José Vial  
Armstrong  
Escuela de Arquitectura y Diseño,  
Pontificia Universidad Católica de  
Valparaíso  
ead.pucv.cl, 198 (top)

Diego Arraigada Arquitectos  
diegoarraigada.com  
53 (bottom, right)

ARX Portugal Arquitectos  
arx.pt, 24

Atelier Bow Wow  
bow-wow.jp, 57 (top)

Barkow Leibinger  
barkowleibinger.com, 85-86

Beinecke Rare Book &  
Manuscript Library, Yale University  
beinecke.library.yale.edu  
129 (bottom)

Bibliothèque nationale de France  
bnf.fr, 141 (bottom)

Bjarke Ingels Group  
big.dk  
154 (top, left & right); 210 (top)

Mario Botta Architetto  
botta.ch  
128 (middle, top & middle, bottom)

Alexander Brodsky, 42; 213 (top)

Canadian Centre for Architecture  
cca.qc.ca, 162 (bottom)

Centraal Museum, Utrecht  
111 (bottom, left)

Chicago History Museum  
chicagohistory.org, 183 (top)

CODA  
co-da.eu, 63 (bottom, left)

Code: Architecture  
code.no, 129 (top & middle, left)

Cornell University, Department of  
Architecture  
aap.cornell.edu/academics/architec-  
ture, 15-17

Decker Yeadon LLC  
deckeryeadon.com  
96 (top, right, middle & bottom)

Diller Scofidio + Renfro  
dsrmy.com, 31 (bottom); 159

dosmasunoarquitectos  
dosmasunoarquitectos.com  
166 (bottom, right)

Eisenman Architects  
eisenmanarchitects.com  
53 (middle); 187 (bottom)

Ensamble Studio  
ensemble.info  
74 (top, left); 99 (middle & bottom);  
198 (middle, bottom, left & right);  
204 (top, left)

EPIPHYTE Lab  
epiphyte-lab.com, 62 (top)

The Estate of R. Buckminster Fuller  
buckminsterfuller.net, 191 (left)

Fondation Le Corbusier  
fondationlecorbusier.fr  
126, 147 (bottom); 187 (top)

Fondazione Aldo Rossi  
fondazionealdorossi.org  
10; 35 (top, left); 110

Fondazione Il Girasole  
61 (bottom)

Foreign Office Architects  
61 (top, right)

The Frank Lloyd Wright Foundation  
Archives, Avery Architectural &  
Fine Arts Library,  
Columbia University  
franklloydwright.org/about/Archives  
210 (middle)

Carlo Fumarola Architekt ETH  
crola.ch, 92 (top)

Fundación Anala y Armando  
Planchart  
fundacionplanchart.com  
34 (bottom, left)

Gigon/Guyer Architekten  
gigon-guyer.ch  
129 (top, right, middle & middle,  
right)

Grafton Architects  
graftonarchitects.ie  
70 (top, right)

Guerrilla Office Architects  
g-o-a.be, 166 (top)

Michael Hansmeyer  
michael-hansmeyer.com  
200 (top)

Herzog & de Meuron Basel Ltd.  
herzogdemeuron.com  
31 (top, right)

Steven Holl Architects  
stevenholl.com  
20; 35 (middle)

Höweler + Yoon Architecture  
hyaarchitecture.com  
123 (middle)

Inaqui Carnicero Architecture  
Office  
inaquicarnicero.com  
152 (bottom, left)

IwamotoScott Architecture  
iwamotoscott.com  
194 (right)

Jakob & MacFarlane Architects  
jakobmacfarlane.com  
87 (top, right)

Jarmund/Vignæs AS Arkitekter  
MNAL  
jva.no  
23 (top, right)

José María Sánchez Architects  
jmsg.es  
169 (bottom)

Kennedy & Violich Architecture  
kvarch.net  
96 (top & bottom, left)

Labics  
labics.it, 130 (bottom)

Louis I. Kahn Collection, The  
University of Pennsylvania and  
the Pennsylvania Historical and  
Museum Commission  
design.upenn.edu, 175 (bottom); 176

LTL Architects  
ltlarchitects.com  
35 (top, right)

Machado and Silveti Associates  
machado-silveti.com, 13 (top)

Massimiliano Fuksas Architetto  
fukkas.it, 71 (top, right)

Matsys  
matsysdesign.com, 215 (bottom)

Richard Meier & Partners  
Architects LLP  
richardmeier.com, 14; 127 (top)

Metro Arquitetos Associados  
metro.com.br, 68

Morger Degelo Kerez Architekten  
94 (top, right)

Morphosis Architects  
morphosis.com, 29; 30

Musées de Strasbourg  
musees.strasbourg.eu, 122 (middle)

The Museum of Modern Art  
moma.org  
31 (top, left); 63; 122 (bottom);  
168; 213 (bottom, right)

MVRDV  
mrvd.nl  
177 (middle, left & right & bottom)

Nacasa & Partners Inc.  
nacasa.co.jp  
23 (middle & bottom)

Netherlands Architecture Institute  
nai.nl, 167

Ben Nicholson, 214 (top)

Paulo David Arquitecto Lda  
171 (bottom, left)

Pezo von Ellrichshausen/  
Mauricio Pezo & Sofia von  
pezo.cl, 70 (middle, left)

Eugenius Pradipto  
designboom.com  
97 (bottom)

Preston Scott Cohen, Inc.  
pscohen.com, 35 (bottom)

Richard Nickel Archive, Ryerson and  
Burnham Archives, The Art Institute  
of Chicago  
artic.edu, 171 (top)

Ronald Feldman Fine Arts, Inc.  
feldmangallery.com  
213 (top)

Royal Institute of British Architects  
Library Books & Periodicals Collection  
architecture.com  
113 (bottom); 192 (bottom)

Jenny Sabin  
jennysabin.com, 61 (top, left); 201

Shigeru Ban Architects  
shigerubanarchitects.com, 75; 76

SHoP Architects  
shoparc.com  
163 (top & middle); 200 (bottom)

Simón Vélez/DeBoer Architects  
deboerarchitects.com, 97 (middle)

Spaceshift Studio  
spaceshiftstudio.com, 199 (bottom)

Studio 8 Architects  
studio8architects.com, 215 (top)

Studio Granda  
studiogranda.is, 54 (top, right); 159

Trahan Architects  
trahanarchitects.com, 195

Bernard Tschumi Architects  
tschumi.com  
155 (top, left); 169 (top, left & right);  
214 (bottom)

UNStudio  
unstudio.com  
32 (top); 55 (top, right); 193

Zaha Hadid Architects  
zaha-hadid.com  
25 (top, left & right, middle);  
130 (top, left); 211; 212

# Photographer Credits

Photographs courtesy of the authors with the exception of the following:

Courtesy of 3Gatti, 131 (bottom, left & right), Travis J. Aberle, 120 (middle, right), Courtesy of Allied Works Architecture, 25 (bottom, left & right), Luis Ferreira Alves, 170 (top), ©Pirak Anakayawachon/Spaceshift Studio, 199 (bottom), Archivo Histórico José Vial Armstrong Escuela de Arquitectura y Diseño, PUCV, 198 (top), Gianluca Aresta, ITS LAB—1 Think Sustainable Laboratory, 71 (middle, left), ©Pétur H. Armannsson, 110 (middle, left), ©Anna Armstrong, 119 (middle, left), ©Arnauld Duboys Fresney Photographe, 160 (top, left), ARX Portugal Arquitectos, 24, Atelier Bow Wow, 57 (top), Peter Bardell, 123 (top, left), Barlow Leibinger, 85, David Barragan, 205 (top, left, middle & right), Joaquim Barros, 146 (top, right), Bednorz-Images, 182 (top, right), Courtesy of Benjamin Benschneider, 18 (right), Bernard Tschumi Architects, 155 (top, left); 169 (top, left & right); 214 (bottom), Jordan Berta, 174 (top, left), ©Hélène Binet, 212 (top, right), Courtesy of Bjarke Ingels Group (BIG)/big.dk, 154 (top, left & right); 210 (top), Cameron Blaylock/cameronblaylockphoto.com, 115 (bottom), Ignacio Borrego, Néstor Montenegro, Lina Toro/dosmasuno arquitectos/Photo: Miguel de Guzmán, 166 (bottom, right), Courtesy of Mario Botta, Architetto/Photo: Alo Zanetta, 128 (middle, top), Mario Botta, Architetto, 128 (middle, bottom), From Robin Boyd, Kenzo Tange, New York: Braziller, 1962, 182 (bottom), Alexander Brodsky, 42, Burçin YILDIRIM, 22 (top, right), Burnham Pavilion in Chicago's Millennium Park, 2009, ©UNStudio, 191 (bottom), Burnham Pavilion in Chicago's Millennium Park, 2009, UNStudio/©Christian Richters, 193 (top), Chalmers Butterfield, 140 (top, left), Barnabas Calder, 175 (top), Canadian Centre for Architecture, 162 (bottom), Ibaqui Carnicero/I. Via A. Viseda, 152 (bottom, left), ©Lluís Casals, 54 (top, left), Celtus, Creative Commons, 186 (top, right), Centraal Museum, Utrecht, 11 (bottom, left), Evan Chakroff, 66 (top), Shu Chang, 136 (left), Hong Ji Chen, 199 (top, right), Kimberley Chew, 17, Chicago History Museum, 183 (top), Justin Chu, 15 (middle), Justin Clements, 69 (top, left), Courtesy of CODA, 63 (bottom, left), Code: Arkitektur AS, 128 (middle, left), Wayne Copper, Cornell University, 50 (top, left), Cornell University, Department of Architecture, 15 (bottom); 16, ©Conor Cotter, 75 (top), Nils Petter Dale, 23 (top, left), ©DeBoer Architects/Simón Vélez, 97 (middle), Courtesy of Dia Art Foundation/Photo: John Cietti, 149 (bottom), ©Didier Boy de la Tour, 76 (top, right), ©Diego Arraigada Architects and Johnston Marklee, 53 (bottom, right), Digital scan from printed map (no copyright information, recto or verso), printed in Denmark by Permill & Rosen-gren c. 1957, in collection of Beinecke Rare Book & Manuscript Library, Yale University, New Haven, CT, 129 (bottom), Courtesy of Diller Scofidio + Renfro, 31 (bottom), Drawings: Mikhail Grinwald, 34 (top); 94 (top, left), Drawing from *Arabian Antiquities of Spain*, by James Cavanagh Murphy, 1816; reproduction by Kroch Library, Cornell University, 182 (top, left), Drawings: Anh K. Tran, 69 (middle, right); 81 (bottom); 104 (right); 177 (top); 178 (right); 179 (top & middle); 184 (bottom); 186 (top, middle), Ludovic Dusuzau/Elementa, Tadeuz Jalocha, 163 (bottom, right), Courtesy of Eisenman Architects, City of Culture of Galicia, study model, 1999, 53 (middle), Courtesy of Eisenman Architects, 187 (bottom), Courtesy of Pezo von Ellrichshausen, 70 (middle, left)

©Courtesy of Ensemble Studio/ensemble.info, 99 (middle & bottom); 198 (middle, bottom, left & right); 204 (top, left), Courtesy of EPIPHYTE Lab, 62 (top), Jonathan Esslinger, 163 (bottom, left), The Estate of R. Buckminster Fuller, 191 (left), Marloes Faber, 10 (top, right), Courtesy of Per Olaf Fjeld, reproduced from *Sverre Fehn: The Pattern of Thoughts*, 22 (top, left & middle), Fondation Le Corbusier, 126; 147 (bottom); 187 (top), Fondazione Il Girasole/Angelo e Lina Invernizzi, 61 (bottom), Foreign Office Architects, 61 (top, right), ©David Franck, 32 (bottom), The Frank Lloyd Wright Foundation Archives (The Museum of Modern Art/Avery Architectural & Fine Arts Library, Columbia University, New York), 210 (middle), Frederick C. Robie Residence, Chicago, IL, 1906-1909, Frank Lloyd Wright, architect, Richard Nickel Archive, Ryerson and Burnham Archives, The Art Institute of Chicago, Digital File #201006\_120118-014 © The Art Institute of Chicago, 171 (top), Yona Friedman, 207 (bottom), Andrew Fu, Cornell University, B.Arch, 2014, 94 (middle & bottom); 128 (bottom), Carlo Fumarola/crola.ch, 92 (top), Fundación Anala y Armando Planchart, 34 (bottom, left), Aurelio Galletti & Flora Ruchat/Drawing: Anh K. Tran, 170 (bottom), Genesis by David Adjaye for Design Miami, 2011, 97 (top, left & right), ©Gigon-Guyon/Gigon/Guyon Architekten/Photo: ©Henrik Helfenstein, 129 (top, right, middle & middle, right), ©Giselbrecht, 152 (top & middle, left & right & bottom, right), Paola Giunti, 143 (top, right), Eileen Gray Archive/Photo: Eileen Gray, 153 (left, top & bottom), Juan David Grisales, 162 (top), Guerilla Office Architects, 166 (top), Wojtek Gurak/bywojtek.net, 99 (top); 130 (top, right), ©R. Halbe, 85 (middle), ©2013 Duyi Han, 69 (middle, left), William Harbison, 204 (bottom, left), ©Ron Herron of Archigram/Ron Herron Archive, 213 (bottom, left), Herman Hertzberger, 13 (bottom), ©Herzog & de Meuron, 31 (top, right), Detail of drawing by Thomas Holme, Library of Congress, 184 (top), Courtesy of Höweler + Yoon Architecture, 123 (middle), Arthur Huang, Jarvis Liu/Miniwiz, Ltd., 63 (top), Li Kwan Ho Felita, 174 (bottom), Hugh Ferriss Architectural Drawings and Papers Collection, Avery Drawings and Archives, Columbia University, 212 (bottom), FG-SG Architectural Photography, 53 (top), Figure from *Architectural Space in Ancient Greece* by Constantinos A. Doxiadis, published by MIT Press, 102 (top), Leonard Finotti, 92 (bottom), Thomas Flagg, 107 (top), flickr.com/photos/marinanina/2068310964, 111 (bottom, right), Courtesy of Kenneth Frampton, 69 (bottom), *Flagellation of Christ*, by Piero della Francesca, collection Galleria Nazionale delle Marche, Urbino, Italy, (public domain), 105 (bottom), ©Gustavo Frittegotto, 53 (middle, bottom), Photo: Masako Fujinami, 154 (bottom), Carol M. Highsmith, *This is America!* Library of Congress Collection, 77 (bottom), ©Eduard Hueber/archphoto.com, 95 (middle & bottom), *In the public domain*, 84 (top, right); 102 (bottom); 185 (bottom, right); 186 (bottom); 190 (bottom), Donald Ingber, 191 (right), IwamotoScott Architecture, 194 (right), Joelle Lisa Jahn, 131 (top), Jakob & MacFarlane Architects/R. Borel Photography, 87 (top, right), Tadeuz Jalocha, 163 (bottom, left), Aris Jansons, 143 (bottom), Jarmund/Vignasnes AS Arkitektur MNAL, 23 (top, right), Xavier de Jaurégui, 123 (bottom), Mitchell Joachim, Maria Aiolova, Melanie Fessel, Emily Johnson, Ian Slover, Phil, Weller, Zachary Aders, Webb Allen, Niloufar Karimzadegan, 63 (bottom, right), José María Sánchez Architects, 169 (bottom)

Taleen Josefsson, 185 (top), Deuk Soo Jung, 47, Tad Jusczyk, 115 (top, left), Drawing: Mia Kang, 153 (top, right), Aya Karpink, 103 (bottom, left), Emil Kaufmann, "Three Revolutionary Architects" in *Transactions of the American Philosophical Society*, Vol. 42, Part 3, p. 545, 1952, 141 (bottom), Ros Kavanagh, 70 (top, right), Joseph Kennedy, 135 (bottom), ©Kennedy & Violich Architecture/kvarch.net, 96 (top & bottom, left), Yongkwon Kim, 199 (top, left), Florestan Korp, 160 (middle & bottom, left & right), Andrew Kovacs, 39, ©Yoshinori Kuwahara, 148 (top), Natalie Kwee, 33 (bottom), Labics, 130 (bottom), Ryan Lancaster, 115 (top, right), ©Andreas Lechtape, 121 (right), James Lewicki, 111 (top), Paul Lewis, Marc Tsurumaki, David Lewis, Alex Terzick, 35 (top, right), Licensed by SCALA/Art Resource, NY, 28 (left), ©C. J. Lim/Studio 8 Architects, 215 (top), Tiffany Lin, 66 (bottom, left & right), Arwen O'Reilly Griffith, 43, ©Jeff Lodin, 41, *Lorus International*, 22, 178, 142 (top), Louis I. Kahn Collection, The University of Pennsylvania and the Pennsylvania Historical and Museum Commission, 175 (bottom); 176, Lanfranco Luciani, 71 (top, left), Mark Lyon, 114 (bottom), Machado and Silvetti Associates, 13 (top), Massimiliano and Donata Fuskas, Architects/Photo: Moreno Maggi, 71 (top, right), Arni Sv. Mathiesen, 206 (left & right), ©2012 Matsys, 215 (bottom), Mitsuo Matuoka, 121 (middle), Creative Commons, 142 (middle), ©Stephen McCathie, 75 (bottom), Ken McCow, 120 (top), Stefano Abbadesse Mercanti, 71 (bottom), José María Lavena Merino, 74 (top, right), Metro Arquitectos Asociados, 68, Enric Miralles and Carme Pinós, 28 (right), Leonard Mirin, 161 (bottom), Mobius House, 1995, UNStudio/© Christian Richters, 55 (bottom, right), Rafael Moneo, 134 (bottom, left), Photo by Michael Moran, 113 (top), Morger Degelo Kerez Architekten, 94 (top, right), Courtesy of Morphosis Architects, 29; 30, ©Musées de Strasbourg/IM Bertola, 122 (middle), ©The Museum of Modern Art/Licensed by SCALA/Art Resource, NY, 31 (top, left); 122 (bottom); 168; 213 (bottom, right), Courtesy of MVRDV, 177 (middle, right & bottom), Courtesy of MVRDV/Photo: © Robt Hart, 177 (middle, left), Nacasa & Partners Inc., 23 (middle & bottom), Leo T. Naegele, 148 (bottom), Jonathan Dietrich Negron, 105 (top), Netherlands Architecture Institute, 167, Ben Nicholson, 214 (top), Courtesy of Nike, 201 (bottom), ©Allen Nolan, 46, ©Nicole Nuñez, 86 (bottom), Victor Oddó, 70 (middle, right), Ken Ohyama, 158 (left), Ziver Olmez, 154 (middle), Courtesy of Orfeus Publishing, reproduced from *Sverre Fehn: Samlede Arbejder*, 21 (right); 23 (bottom), John Ostlund, 183 (bottom), Larisa Ovalles, 118 (top, left), Mia Ovčina, 15 (top), Cristobal Palma, 70 (top, left), ©Paulo David Arquitecto Lda, 171 (bottom, left), James Pelletier, 194 (left), Pier Luigi Nervi Project Association, Brussels, 77 (top), From Giovanni Battista Piranesi, *Le Carceri d'Invenzione*, Rome, 1761, (public domain), 120 (middle, left), Karel Polt, 142 (bottom), Eduardo Ponce, 66 (middle, right), Neil Poole, 190 (top, left), ©Eugenius Pradipto, 97 (bottom), ©Matthias Preisser/matthiaspreisser.ch, 94 (top, middle), Preston Scott Cohen, Inc., 35 (bottom), Printing kept at the public library of Varese. This reproduction was realized by the Municipal Administration on the occasion of the ceremony for the Unesco's certificate registration of the site, 55 (top, left), Private Collection, 10 (top, left), psmod.com.org, 206 (top, right), Wajeha Qureshi, 115 (top, middle), Mahuqur Rahman/Arlington, Virginia, 134 (top)

Reproduced from Bernard Rudofsky's *Architecture without Architects*. Wulf-Diether Graf zu Castell Munich/Reim, 56 (bottom). Reproduced from Klaus Herdeg's *Formal Structure in Indian Architecture*, (1967), 54 (bottom). Reproduced from Philibert de l'Orme, *Architecture de Philibert de l'Orme ... Oeuvre entiere contenant onze livres, augmentée de deux ...* Kroch Library, Cornell University, (public domain), 192 (top, left & right). Reproduced from Thomas L. Schumacher's *Surface and Symbol: Giuseppe Terragni and the Architecture of Italian Rationalism*, drawing #31, 34 (bottom, right). Reproduced from Spazio, Vol. 3, No. 6, December 1951–April 1952, 12. Reproduced from Spazio, Vol. 7, December 1952–April 1953, 11: 104 (right). Courtesy of Richard Meier & Partners Architects LLP, 14: 127 (top). ©Siobhan Rockcastle, 62 (bottom); 79. Courtesy of Ronald Feldman Fine Arts, New York/feldmangallery.com, 213 (top). Richard Rosa, 40. ©Corinne Rose, 86 (top, left & right). Aoiie Rosenmeyer, 112 (bottom). ©Eredi Aldo Rossi, 35 (top, left). Aurélien Le Rou, 141 (top, right). Royal Institute of British Architects Library Books & Periodicals Collection, 115 (bottom); 192 (bottom). Andy Ryan, 120 (bottom). Jenny Sabin, 61 (top, left); 201 (top). Mikaela Samuelsson, 155 (top, right). Saranago, Pedro/Mãe D'Água, Lisboa, Portugal, 2012, 146 (bottom, right). Nathaniel Saslfsky, 121 (left). From Ottavio Bertotti Scamozzi, *Le*

*fabbriche e i disegni di Andrea Palladio*, Vicenza, 1796: Kroch Library, Cornell University, (public domain), 106 (right). From Karl Friedrich Schinkel, *Sammlung architektonischer Entwürfe: enthaltend 148 Kupfer-Tafeln mit erläuternden Text*, Potsdam, 1841–1843; Kroch Library, Cornell University, (public domain), 107 (bottom). Chris Schroerer-Heiermann, 199 (top, middle). Michael Schroeter, 190 (top, middle). Scott Schultz, 66 (middle, left). ©Kyle Schumann, 50 (bottom). Michael Schwarting, 206 (top, left). Davide Secchi, 149 (top). Seier + Seier, 178 (left). Courtesy of Shigeru Ban Architects, 76 (left). Courtesy of Shigeru Ban, Architects/Photo: ©Hiroyuki Hirai, 76 (bottom, right). SHoP Architects, PC, 163 (top & middle); 200 (bottom). Sigurður Sigurjónsson, 159 (bottom, left). ©Petr Smidek, 56 (top). ©Margherita Spiluttini, 91; 95 (top). Courtesy of Steven Holl Architects, 20: 35 (middle). Still Life, c.1952 (oil on canvas). Morandi, Giorgio (1890–1964)/Private Collection/The Bridgeman Art Library, 119 (bottom). Francis Strauven, 45. Studio Granda, 54 (top, right). Subdivided Columns, Michael Hansmeyer, 2010, 200 (top). Matthew Sweets, 204 (bottom, right). Ida Tam, 159 (top). 182 (middle). Roland Tännler, 207 (top). Photo: Taxiarchos228, 174 (top, right). Team Leader: Dana Cupkova, Design Team: Monica Alexandra Freundt, Andrew Heumann, Daniel Quesada Lombo, Damon Wake/Photo:

Andrew Heumann, 33 (top, right). Team Leader: Dana Cupkova/Design Team: Monica Alexandra Freundt, Andrew Heumann, Daniel Quesada Lombo, Damon Wake, Consultant: William Jewell, Ph.D., 33 (top, left). ©Teatro Regio Torino/Photo Ramella & Giannessi, 143 (top, left). Mari Tefre/Global Crop Diversity Trust, 57 (bottom). Skylar Tibbitts, 153 (bottom). Janice Tostevin/jhtostevin@ntlworld.com, 140 (bottom). Trahan Architects, 195. Anh K. Tran, 140 (top, right). Turismo FVG ph Fabrice Gallina, 190 (top, right). Courtesy of UNStudio, 32 (top); 55 (top, right). Omar Uran, 159 (middle). Mauricio Vioto, 74 (bottom); 78; 81 (top); 106 (left); 122 (top). From *Visionary architects: Boullée, Ledoux, Lequeu*, Catalogue of an exhibition held at the University of St. Thomas, 1968, (public domain), 141 (top, left). ©Rajesh Vora, 60 (top). Jarle Waehler, 129 (top, left). ©Michael Webb, 112 (top). Kathy Wesselman, 119 (top, left & right). Julian Weyer, 71 (middle, right). Wikipedia, 38 (left); 69 (top, right); 192 (middle). Allison Wills, 146 (left). Duncan Wilson, 128 (top). ©Decker Yeadon LLC/deckeryeadon.com, 96 (top, right, middle & bottom). ©2010 Sophie Ying Su/sophieness.com, 119 (middle, right); 204 (top, right). Zaha Hadid Architects, 25 (top, left & right, middle); 130 (top, left); 211; 212, Lisa Zhu, 147 (top). Giorgio Zucchiatti, 110 (bottom)

## Index

- Aalto, Alvar, 110, 177  
 Abierta, Ciudad, 198  
 Acropolis, 78  
 Adaptive Component Seminar (2009), 33  
 Adler and Sullivan, 166  
 Adier House, 176  
 Agrarian Graduate School of Ponte de Lima, 137  
 Allied and Arts Industries, 206  
 Altes Museum, 107  
 Aluminaire, 206  
 analysis  
 abstraction, 14–15  
 coauthorship, 16  
 components, 14  
 diagramming, 15  
 intermediary devices, 15–17  
 interpretation, 15–17  
 precedent, 10, 13  
 project givens, 10  
 Ando, Tadao, 121  
 Appliance House, 214  
 Arc de Triomphe, 38, 147  
 Arch, B., 17  
 Arch of Augustus, 38  
 Arp, Hans, 122  
 Arts Center (Portugal), 171  
 Asplund, Erik Gunnar, 186  
 Astaire, Fred, 142  
 Astana National Library, 154  
 Athenium, 127  
 Auditorium Building (Chicago), 166  
 Autodesk Inc., 153  
 Automobile Museum (China), 131  
 Bacardi Rum bottling plant, 80  
 Bagsvaerd Church, 178  
 Bamboo Garden, 160  
 Bandel, Hannskar, 115  
 Barlinthaug Consult, 57  
 Barragan, David, 205  
 Barragan, Luis, 122  
 Barrière du Trône, 142  
 Batay-Csorba, Andrew, 194  
 BCHO Architects, 199  
 Behnisch, Gunther, 74  
 Behrens, Peter, 183  
 de Beistegui Penthouse, 147  
 Belvedere, 71  
 Berkel, Ben van, 32, 55  
 Berklee School of Music, 204  
 Berlin Chair, 111  
 Bernini, Gian Lorenzo, 12  
 Bete Giyorgis, 69  
 Bijvoet, Bernard, 114  
 Bissegger, Peter, 115  
 Blanc, Patrick, 149  
 Boa Nova Tea House, 51  
 Bo Bardi, Lina, 71, 127  
 Bocconi University, 70  
 Bordeaux House, 39–40  
 Bordeaux Law Courts, 140  
 Borromini, Francesco, 10, 12, 135  
 Bos, Caroline, 32  
 Botta, Mario, 128  
 Boullée, Etienne-Louis, 141  
 Bourges, Romain de, 104  
 Braghieri, G., 35  
 Brandhorst Museum, 121  
 Brazilian Museum of Sculpture, 67  
 Bremerhaven 2000 competition, 85  
 Brown Derby restaurants, 140  
 Brown, Frank, 175  
 Bruder Klaus Field Chapel, 199  
 Burgo Paper Factory, 77  
 Burnham, Daniel, 193  
 Burnham Pavilion, 193  
 Burri, Alberto, 66  
 Bus Rapid Transit system (Brazil), 162  
 Café Aubette, 122  
 Caffè Pedrocchi, 136  
 Casa das Artes (Arts Quay), 68  
 CaixaForum gallery, 149  
 Calatrava, Santiago, 81  
 Camera Obscura, 200  
 Campidoglio, 137  
 Candela, Felix, 80  
 Carabanchel housing project, 61  
 Cardiff Bay Opera House, 212  
 Carnicero, Iñaki, 152, 175–176  
 Carpenter Center for the Visual Arts, 44  
 Carré d'Art, 185  
 Carthage section, 34  
 Casa da Musica (Portugal), 99  
 Casa das Historias Paula Rego, 56  
 Casa Das Mudias, 171  
 Casa del Fiasco, 34, 87  
 Casa del Popolo, 87  
 Casa Gilardi, 122  
 Casa Girasole (Sunflower House), 61  
 Casa Malaparte, 128  
 Casa Pentimento, 205  
 Casa Polli, 70  
 Case Study House #22, 204  
 CAST, 199  
 Castelvecchio, 115  
 Castle Hedingham, 13  
 Castle of Prague, 137  
 Cenotaph for a Warrior, 141  
 Center for the Advancement of Public Action, 50  
 Center for the Arab World, 123  
 Centre Georges Pompidou, 131  
 Cha, Jae, 47  
 Chanin Building, 210  
 Chapel at MIT, 118  
 Chapel of St. Ignatius, 119  
 Chateau, Pierre, 69, 114  
 Chemetoff, Alexandre, 160  
 Chew, Kimberly, 17  
 Chicago Tribune office, 113  
 Chiesa Nuova, 135  
 Chinati Foundation, 154  
 Chirico, Giorgio de, 10  
 Chrysalis III, 215  
 Church of Santa Maria, 104  
 Church of St. George (Ethiopia), 69  
 Church of the Light (Japan), 121  
 Church of the Sacred Heart (Prague), 143  
 City of Culture of Galicia, 53  
 City of Refuge, 166  
 concept  
 flexibility and, 20, 23  
 ideas compared to, 20  
 material models, 24  
 overlays, 24  
 parti diagram, 24  
 relief models, 24  
 sketches, 23–25

thumb nail sketches, 23–24  
Congress Hall, 10  
context  
environmental context, 56–57  
ephemeral context, 54–56  
extreme variability, 56  
historical, 56  
infrastructural context, 53–54  
layers, 53  
material, 50  
narrative, 55  
networks, 54  
physical context, 50, 53  
scale, 50  
site, 53  
space, 53  
tradition, 55  
weather, 56  
Cortona, Pietro da, 105  
Cretto, 66  
Crown Hall, 183  
Cruveller, Mark, 79  
Cupkova, Dana, 53  
Cushicle, 112  
Dalbet, Louis, 114  
Danish Design Center, 15  
datum  
axis, 170  
grid, 170  
horizon, 170  
mass, 170  
space, 169  
surface, 166, 169  
David, Paolo, 171  
Debord, Guy, 129  
defamiliarization  
accident, 148  
appropriation, 147  
decontextualization, 148  
extension of awareness, 149  
operations, 147–148  
poetics, 149  
reception, 148–149  
receptivity, 148  
recontextualization, 148  
subversion, 147–148  
wonder, 148  
De Maria, Walter, 149  
Désert de Retz, 141  
Design Miami 2011 fair, 97  
Destailleur, François-Hippolyte, 204  
Dia Foundation, 149  
dialogue  
addition, 136  
contrast, 136  
enrichment, 136  
indexing, 137  
redirection, 136  
scales of, 137  
Doesburg, Theo van, 122  
Doges Palace, 134  
Dominus Winery, 92  
Double Chimney House, 57  
Doxiadis, Constantinos, 102  
Duganne, Jack, 30  
Dürer, Albrecht, 185  
Dymaxion House, 191  
Dynamic Façade, 152  
Eames, Charles, 185  
Eames, Ray, 185  
East River Waterfront Esplanade, 163  
EatMe Wall project, 33  
EcoARK, 63  
Eggen, Arne, 79  
Einar Jonsson House, 50  
El Camino de Santiago, 126  
El Greco Congress Center, 134  
Entenza, John, 204

environment  
energy, 62  
holistic view, 62  
instrumentation, 60–62  
materials, 62  
passive instrumentation, 60  
recycled materials, 62  
remediation, 62  
responsive instrumentation, 60, 62  
static instrumentation, 60  
sustainable environments, 62–63  
Epi-phyte Lab, 62  
Erechthelion, 78  
e-Skin project, 61  
Europa City, 210  
Eyck, Aldo van, 45  
fabrication  
craft, 199  
digital fabrication, 200  
dilling Water, 210  
Fehn, Sverre, 21–22, 98  
Fencing Academy (Rome), 11  
Ferris, Hugh, 210  
Fiat automobile factory, 112  
Fibonacci series, 190  
Fiorentino, Mario, 71  
Fleisher House, 176  
Fong, Steven, 111  
Formal Structure in Indian Architecture exhibition, 54  
Forster, Kurt, 107  
forum of Pompeii, 179  
Fosse Ardeatine, 71  
Foster, Norman, 154  
Francesca, Piero della, 105  
Frederick C. Robie House, 171  
Freedom Trail, 158  
Freitag, 207  
Freundt, M., 33  
Frey, Albert, 206  
Friedman, Yona, 207  
Füeg, Franz, 90  
Fuks, Massimiliano, 71, 98  
Fun Palace, 162  
Galfetti, Aurelio, 170  
Galician Center of Contemporary Art, 51–52  
Gallaratese II Housing, 10  
García-Abril, Antón, 74  
Gateway Arch, 115  
Gehry, Frank, 142  
Genesis pavilion, 97  
geometry  
Boolean operations, 193  
building information modeling (BIM), 195  
complexities, 193–194  
constructive solid geometry (CSG), 193  
descriptive geometry, 192–193  
golden ratio, 190  
networks, 194–195  
numbers, 190  
parametrics, 193–194  
variability, 194  
German Pavilion (International Exhibition, Barcelona), 148  
Giedion, Sigfried, 103  
Giorgio Martini, Francesco di, 186  
Glama Kim Architects, 206  
Glass House, 155  
Global Seed Vault, 57  
Goethe, Johann Wolfgang von, 121  
Gogol, Nikolai, 141  
Goldenberg House, 176  
Gothenburg Town Hall (Sweden), 186  
Grand Canal (Venice), 169  
Gray, Eileen, 153  
Greek cross, 176  
Green Negligee, 62

grids  
proportions, 186–187  
reference, 185–186  
rhythm, 186  
tartan grid, 186  
Guarini, Guarino, 104  
Guggenheim Museum, 128  
Gwangju Design Biennale, 200  
Habitat '67, 174  
Haesley Nine Bridges Golf Club House, 76  
Hakozaki Interchange, 158  
Hamar Bispegaard Museum, 98  
Hangar 16 (Spain), 152  
Hanil Visitors Center & Guest House, 199  
Hannover Merzbau, 115  
Harris, Kerensa, 30  
Hays, K. Michael, 183  
Heatherwick Studio, 94  
Hedmark Cathedral Museum, 22  
Hejduk, John, 167–168  
Hemeroscopium, 74  
Henan province, 56  
Hendrix, Jimi, 140  
Herdeg, Klaus, 54  
Herron, Ron, 213  
Hertzberger, Hermann, 13  
Herzog, Jacques, 31, 41, 91–93, 95, 149, 174  
Heumann, A., 33  
Hoenheim-Nord Terminus and Car Park, 212  
Holl, Steven, 20, 35, 119–120  
Holme, Thomas, 184  
Homeostatic Façade System, 96  
House II, 187  
House in Djerba, Tunisia, 13  
House in Pound Ridge, 14  
Hringbraut & Njardagata, 159  
HSBC Building (Hong Kong), 154  
Hutton, Sauerbruch, 121  
IBA Housing, 212  
Icelandic turf house, 60  
Ihida-Stansbury, Kaori, 61  
IIT, 183  
infrastructure  
anticipatory networks, 161  
circulatory networks, 161  
context, 53–54  
cultural networks, 160–161  
evanescent, 160  
physical, 158, 160  
scales of engagement, 160  
system armatures, 158, 160  
Ingber, Donald, 191  
Integral Urban Project, 159  
International Exhibition (Barcelona), 148  
Ito, Toyo, 20, 23  
Ivernizzi, Angelo, 61  
James Corner Field Operations, 159  
Jappelli, Giuseppe, 136  
Jewell, W., 33  
J. Mayer H., 32  
Johannesson, Sigvald, 107  
John F. Kennedy Airport, 140  
John Nichols Printmakers, 29  
Johnson Museum (New York), 69  
Johnson, Philip, 118, 155  
Johnson Wax Headquarters, 77  
Judd, Donald, 154  
Kahn, Louis, 123, 175–176, 179  
Kahn's Dominican Sisters, 179  
Kantana Film and Animation Institute, 199  
Karkkainen, Maija, 21  
Kaufmann, Edgar J., 210  
Kepes, György, 103  
Kiefer, Technic Showroom, 152  
Kimbell Art Museum, 123  
Kocher, A. Lawrence, 206  
Koenig, Pierre, 204

- Kolbe, Georg, 148  
 Koolhaas, Rem, 39  
 Kudless, Andrew, 215  
 Kufferman, David, 195  
 Kulve, Thor ter, 160  
 Kunsthal, 40  
 Kunstmuseum, 94  
 Kurokawa, Kisho, 205  
 Kursaal Auditorium and Congress Center, 113  
 KVA, 96
- Landscape Formation-One, 130  
 Largo de João Franco, 160  
 Laser Machine and Tool Factory, 85  
 Laurenz Foundation, 93  
 Lavis, Fred, 107  
 Leatherbarrow, David, 95  
 Le Corbusier, 34, 44, 47, 103, 117, 118, 119, 126, 147, 166, 187, 190  
 Ledoux, Claude-Nicolas, 45, 142  
 Le Fresnoy Art Center, 169  
 Leite Siza, Álvaro, 53  
 Lequeu, Jean-Jacques, 84, 141  
 Lewis, David J., 16, 212  
 Libera, Adalberto, 128
- light  
 chiaroscuro, 121  
 color, 121–122  
 distortion, 121  
 instruments, 122  
 perceptual color, 122  
 spatial transformation, 118, 121  
 symbolic color, 121  
 textures, 118
- Lim, C. J., 215  
 Lincoln's Inn Fields, 43  
 Lin, Maya, 134  
 London Design Festival, 75  
 Loos, Adolf, 115  
 Louisiana Sports Hall of Fame Museum, 195  
 Lower Roadway (New Jersey Route 139), 107  
 Lowry, Glenn, 204  
 LTL Architects, 35, 212  
 Lucia, Andrew, 61  
 Lu Wenyu, 66
- Mãe D'Água Amoreiras Reservoir, 146  
 Maison Carrée, 185  
 Maison de Verre, 69, 114  
 Manhattan Transcript, 214  
 Mardel, Carlos, 146  
 Marklee, Johnston, 53
- mass  
 additive processes, 66  
 characteristics, 70–71  
 density, 70  
 gravity, 70  
 processes, 66, 69  
 subtractive processes, 69
- materials  
 acoustic, 94  
 assembly, 98  
 bamboo, 97  
 behaviors, 94–96  
 characteristics, 90, 94  
 constructive processes, 97–98  
 cultural indices, 99  
 detail/jointure, 98  
 environmental changes, 98  
 indices, 99  
 manufacturing methods, 97  
 models, 24  
 nanotechnologies, 96  
 permeability, 94  
 phenomenal characteristics, 90, 94  
 program indices, 99  
 responsiveness, 95  
 site indices, 99  
 smart materials, 96  
 textures, 94  
 weather and, 95
- Mathiesen, Öli, 206  
 Matté Trucco, Giacomo, 112  
 MAXXI Museum of XXI Century Arts, 25  
 Mayne, Thom, 29–30, 194  
 Melville, Herman, 12  
 Memorial Sloane-Kettering Cancer Center Lobby, 35  
 Memorial to the Martyrs of the Deportation, 171  
 Mendes da Rocha, Paulo, 67–68  
 Method Design, 195  
 Metrocable San Javier, 159  
 Metropol Parasol, 32  
 Meuron, Pierre de, 31, 41, 91–93, 95, 149, 174  
 Michelangelo, 11, 28, 84, 137, 190  
 Mies van der Rohe, Ludwig, 11, 31, 148, 183  
 Milan Biennale, 213  
 Millcreek Apartments, 176  
 Milwaukee Art Museum, 81  
 MINIWIZ, 63  
 Mirador (Spain), 177  
 Miralles, Enric, 28  
 Möbius House, 55  
 Modulor 2 proportioning system, 190  
 Mollino, Carlo, 143  
 MoMA (Museum of Modern Art), 63, 168, 204  
 Monastery of the Lima Refóios, 137  
 Mondrian, Piet, 111  
 Moneo, Rafael, 54, 113, 134  
 Monville, Françoise Racine de, 141  
 Morandi, Giorgio, 119  
 Moretti, Luigi, 11–12, 104  
 Mosque-Cathedral of Córdoba, 182  
 Mostafavi, Mohsen, 95  
 Moura, Souto, 56
- movement  
 amplification, 130  
 attenuated, 128  
 continuous, 128  
 curating space, 126–127  
 dialogue, 130  
 filmic, 126  
 interface, 130  
 interrupted, 129  
 narrative, 127  
 parallel sequences, 131  
 processional, 126  
 random, 129  
 sequence, 128–129  
 simultaneous sequences, 131  
 theatrical, 127
- Munich Olympic Stadium, 74  
 Murphy, James Cavanah, 182  
 Museum and Park Kalkriese, 129  
 Museum for Roman Artifacts, 54  
 Museum of Graffiti, 98  
 Musical Studies Center (Spain), 99  
 Music Faculty (Austria), 32  
 Music Tower (Berklee School of Music), 204  
 myThread pavilion, 201
- NAi Collection, 167  
 Nakagin Capsule Tower, 205  
 National Congress of Brazil, 179  
 Nationale-Nederlanden, 142  
 National Music Centre, 25  
 National Tourist Routes (Norway), 129  
 National Veterinary Investigation Laboratory, 170  
 Negron, Jonathan, 105  
 Nelson-Atkins Museum of Art, 120  
 Nemesi Architeti Associati, 130  
 Nervi, Pier Luigi, 77  
 New Jersey Route 139, 107  
 New National Gallery, 183  
 New York Earth Room, 149  
 Nicol, F., 61  
 Niemeyer, Oscar, 179  
 Nike Stadium, 201  
 Ningbo Historic Museum, 66  
 Noll, Giambattista, 102  
 Noll Plan of Rome, 69  
 Nordic Biennale Pavilion, 22
- Nordic House, 110  
 Norman Foster + Partners, 185  
 Norwegian Glacier Museum, 21  
 "Nose, The" (Nikolai Gogol), 141  
 Notre Dame du Haut, 119  
 Nouvel, Jean, 123
- O'Donnell, Caroline, 63  
 Olmstead, Frederick Law, 161  
 Olympic Sculpture Park, 158  
 OMA (Office for Metropolitan Architecture), 39–40, 99  
 1111 Lincoln Road garage, 41  
 Orange Cube, 87  
 Oratory Complex of Saint Phillip Neri, 10  
 Oratory of the Filippini, 135
- order  
 aggregation, 178  
 hierarchy, 178–179  
 repetition, 174, 177  
 Östberg, Ragnar, 134  
 Otto, Frei, 74  
 Oudolf, Piet, 159  
 Ovalles, Laisa, 146, 147
- Palazzo Canossa, 84  
 Palazzo dei Conservatori, 137  
 Palazzo del Senatore, 190  
 Palazzo Ossoli, 12  
 Palladio, Andrea, 106, 175  
 Palmanova, 190  
 Pantheon, 122  
 Paper Bridge (France), 76  
 Parc de la Villette, 155, 160  
 parti diagram, 24  
 Party Wall, 63  
 Passage des Panoramas, 104  
 Passage Jouffroy, 104  
 Patriarch Plaza, 68  
 Pavilion for Vodka Ceremonies, 42  
 Peak Leisure Club, The, 211, 212  
 Pei, I. M., 69  
 Pelletier, James, 194  
 Penang Turf Club, 30  
 Penn, William, 184  
 Perot Museum of Nature and Science, 30  
 Perruzzi, Baldassarre, 12  
 Perugini, Giuseppe, 71  
 Pevsner, Nikolaus, 6  
 Pezo, Mauricio, 70  
 Phidias, 78  
 Piano, Renzo, 131  
 Piazza di Spagna, 46  
 Pingusson, Georges-Henri, 171  
 Pinós, Carme, 28  
 Piranesi, Giovanni Battista, 120  
 Pius Church, 90  
 Plečnik, Jože, 137, 143  
 POLLI-Bricks, 65  
 Pompeian house, 121  
 Pont du Gard, 76  
 Ponti, Gio, 34  
 Porch of the Caryatids, 78  
 Pousada Santa Marinha, 135  
 Prada Tokyo, 31  
 prefabrication  
 sitelessness, 206  
 standardization, 204  
 Premthada, Boonserm, 199
- presentation  
 audience, 210, 213  
 documentary, 210  
 evocative, 213  
 media, 213  
 Price, Cedric, 162
- program  
 bodies, dimensional accommodation of, 38  
 codes, 43–44  
 dimensional imperatives, 38, 41  
 empathy, 45  
 empirical aspect, 38, 41–44

- functionality, 42
- hybridization, 46
- innovative program, 45–47
- limitations as advantages, 46–47
- orientation, 43
- relational elements, 42–43
- Proyecto Urbano Integral (Integral Urban Project), 159
- Quadracci Pavilion, 81
- Quesada Lombo, D., 33
- Quinta da Malagueira, 159
- Quinta Monroy, 163
- Rahul Mehrotra Associates, 60
- Rapid Re(f)use: Waste to Resource City, 63
- Rendezvous at Bellevue, 141
- representation
  - analog drawings, 28, 31
  - digital drawings, 32–33
  - sketches, 28
- representations
  - animations, 35
  - axometrics, 34
  - elevations, 34
  - hybrids, 35
  - perspective drawings, 35
  - plans, 34
  - sections, 34
- Richard Rogers Partnership, 140
- Ricola-Europe production and storage hall, 95
- Ricola Warehouse, 91
- Rietveld, Gerrit, 111
- Robinson, Heath, 215
- Rocha, João Alvaro, 170
- Rockcastle, Siobhan, 62
- Rogers, Ginger, 142
- Rogers, Richard, 131
- Rolax Learning Center, 79
- Rome International Exposition, 10
- Rosa, Richard, II, 39–40
- Rowe, Colin, 103
- Royal Saltworks, 45
- Ruchat, Flora, 170
- Rughesi, Fausto, 135
- Saarinen, Eero, 115, 118, 140
- Sacro Monte, 55
- Saez, Jose Maria, 205
- Safdie, Moshe, 174
- Sainte-Marie de La Tourette monastery, 118
- Sala Suggia, 99
- Salvation Army Building, 166
- SANAA, 79
- Sánchez García, José María, 169
- Sanctis, Francesco de, 46
- Sandaker, Bjorn, 79
- San Giovanni dei Fiorentini, 11
- San Lorenzo, 84
- Sanmicheli, Michele, 84
- Sanne, Dyveke, 57
- San Paolo Apostolo, 71
- Santa Maria Church (Portugal), 110
- Santa Maria della Pace, 105
- Santa Maria do Bouro Convent, 135
- Santa Marinha Convent, 136
- Santini, Jan Blažej, 190
- São Paulo Museum of Art, 71
- Sasaki, Matsuuro, 23
- scale
  - body, 110, 112–113
  - interlocking scales, 115
  - multiple scales, 114
  - near and far, 113–115
  - perceptual body, 112–113
  - physical body, 110, 112
  - quotidian versus monumental, 115
- Scamozzi, Vincenzo, 106, 190
- Scarpa, Carlo, 115
- Schinkel, Karl Friedrich, 107, 183
- Schmarzow, August, 102
- Schröder House, 111
- Schwitters, Kurt, 115
- Sculpture Gallery, 118
- Seagram Building, 183
- Seattle Art Museum, 158
- Seed Cathedral, 94
- Self Assembly Lab, 153
- Sendai Mediatheque, 20, 23
- Serigraph, 29
- SESC Pompéia São Paulo Recreation Center, 127
- Shakespeare, William, 6, 142
- Shanghai Expo, 94
- Shklovsky, Viktor, 146
- Siamese Towers, 70
- Sirmitch, Andrea, 16
- Simmons Hall, 20
- Sir John Soane's Museum, 43
- Sixth Order, 200
- Siza, Alvaro, 110
- Siza Vieira, Alvaro, 13, 51–52, 159
- Skylar Tibbits, 153
- Sky Transport (London), 215
- Sloan & Robertson, 210
- Sloan, William, 107
- Slow House, 31
- Slutzky, Robert, 103
- Soane, John, 43
- Søderman, Peter W., 57
- Soft House, 96
- Soltan, Jerzy, 44, 47
- Souto de Moura, Eduardo, 135
- space
  - spatial illusion, 105–107
  - spatial zones, 104–105
- Spanish Steps, 46
- Specchi, Alessandro, 46
- Spillman Echsle Architekten, 207
- S. R. Crown Hall, 183
- Stevens, Wallace, 101
- Stone House, 91
- Stratasy, 153
- structure
  - beams, 79
  - columns, 77–78, 81
  - domes, 80
  - elements, 77–80
  - hybrids, 80
  - slabs, 79–80
  - space, 81
  - space frames, 80
  - trusses, 79
  - vaults, 80
  - walls, 77
- Study of Fortifications Number 27, 28
- Superstudio, 213
- surface
  - interfaces, 87
  - perception, 84, 87
  - performance, 87
- Sydney Opera House, 192
- Taeuber-Arp, Sophie, 122
- Taipei International Flora Exposition, 63
- Tange, Kenzo, 182
- Tata Institute of Social Sciences (TISS), 60
- Távora, Fernando, 135, 136, 137
- Teatro del Mondo, 110
- Teatro Olimpico, 106
- Teatro Regia, 143
- Technology Center (Catholic University), 70
- Tempe à Pailla, 153
- Temple of Diana, 169
- Temporary Housing Shelter (Onagawa), 76
- Terragni, Giuseppe, 10, 34, 87
- Terreform ONE, 63
- Thermal Baths, 66
- T-House, 95
- Ting, Selwyn, 29
- Tokyo Metropolitan Expressway, 158
- Tolo House, 53
- Tour Total, 86
- Town Hall (Reykjavík), 54
- Town Hall (Stockholm), 134
- Trajan's Market, 130
- transformations
  - implied, 153–154
  - literal, 152–153
  - perception and memory role, 154
  - programmatic, 153
  - smart materials, 153
  - temporal, 152
  - theme, 154
  - topological, 152–153
  - variation, 154
- Trenton Jewish Community Center Bath House and Day Camp, 175, 176
- Trinità dei Monti, 46
- Trombe walls, 60
- tropes
  - expressive tropes, 143
  - hyperbole, 142
  - irony, 142
  - metaphors, 140–141
  - metonymy, 141
  - operative tropes, 143
  - personification, 143
  - types, 140–143
  - values and perceptions, 143
- Truffle, 198
- TRUTEC Building, 86
- Tsien, Billie, 50
- Tugendhat House, 11
- Tungneset rest stop, 129
- TWA Flight Center, 140
- Tyng, Anne, 175
- Ungers, Oswald Matthias, 142
- Ungers, Simon, 95
- Unité d'habitation, 190
- Utkin, Ilya, 213
- Utzon, Jørn, 178, 192
- Vairão parish, 170
- Vaux, Calvert, 161
- Verdeau, Passage, 104
- Vertical Garden, 149
- Vienna Hofburg, 50
- Vietnam Veterans Memorial, 134
- Vieu House, 53
- Vignola, Giacomo Barozzi da, 114
- Villa at Carthage, 34
- Villa Planchar, 34
- Villa Savoye, 103, 126
- Villa Schwob, 187
- Vitra Fire Station, 212
- Vitrahhaus, 174
- Wake, D., 33
- Wall Houses, 167–168
- Wang Shu, 66
- Warke, Val, 146, 147, 194
- Washington University Library competition, 176
- Wasserman, Jeff, 30
- Waterfront Greenway Park, 163
- Webb, Michael, 112
- Weiss/Manfredi, 158
- Wells, Jerry, 14, 105
- West, Mark, 199
- Whiteread, Rachel, 104
- Williamson, Jim, 146, 147
- Williams, Tod, 50
- Wills, Allison, 146
- Wolfsburg Cultural Center, 177
- Wright, Frank Lloyd, 77, 103, 128, 171, 183, 210
- Yang, Shu, 61
- Yeadon, Decker, 96
- Zenghelis, Elia, 39
- Zevi, Bruno, 103
- Zhu, Lisa, 147
- Zumthor, Peter, 66, 94, 199

## About the Authors

**Andrea Simitch** is an educator and an architect. She is the Director of the Bachelor of Architecture Program at Cornell University, and an associate professor with tenure. She has also served as Associate Dean of Cornell's College of Architecture, Art, and Planning, and as Director of Undergraduate Studies. She studied architecture at the *École Spécial d'Architecture* in Paris and received her B.Arch. degree from Cornell University in 1979. She began her teaching career at Cornell in 1983 and was the first female architect to be granted tenure in the Department of Architecture there. She teaches courses in architectural design as well as architectural representation and furniture design, with works by her students having been exhibited at the International Contemporary Furniture Fair in New York. She has taught extensively for Cornell in numerous international venues that include Europe, Central America, and South

America. She has been a panelist on the New York State Council on the Arts and a visiting professor at numerous universities including The University of Toronto, Rensselaer Polytechnic Institute, Tunghai University, and The University of Minnesota. She is also a principal of Simitch + Warke Architects, a collaborative practice with work that includes residential, commercial, and speculative projects. Her collages have been included in Joao Alvaro Rocha's monograph *Architectures*, and she has contributed several essays to the *Cornell Journal of Architecture*, most recently "Re-Collage" in number 8.

**Val Warke** is an associate professor at Cornell University's Department of Architecture, where he has been a department chair, a director of graduate studies, and the coordinator of the first year B.Arch. program. In addition to architecture, he is also a member of the graduate field of Fabric Science and Apparel

Design at Cornell. Previously, he was an assistant professor at Harvard University's Graduate School of Design. He has authored numerous essays on architectural design, criticism, and theory, which have appeared in journals such as *Assemblage*, *A+U*, *Cornell Journal of Architecture*, and *Harvard Design Magazine*, as well as in many monographs; and he has collaborated with Thom Mayne in writing the book *Morphosis*. Recently, his research has focused on genre theory, including issues of fashion, formalism, populism, reception, and various associations to literary theory and criticism, especially as related to the work of Mikhail Bakhtin. As a partner in Simitch + Warke, he has collaborated on the design of numerous projects and competitions from the scale of the house to that of the city. He received his B.Arch. from Cornell University and his M.Arch. from Harvard University.

## Acknowledgments

Few books are solitary events, and this one, especially, was a group effort. Everything began when Sheila Kennedy sent this project in our direction. Ashley Mendelsohn helped us get started, plotting the original maps so that we could trace a route. Mikhail Grinwald and Natalie Kwee were with us for the duration, and have done everything—

technologically and logistically—we couldn't possibly have done. Anh Tran, Caio Barboza, Mia Kang, and Mauricio Vieto provided significant assistance along the way. Special thanks are owed to Iñiqui Carnicero, Steven Fong, Michael Hays, David Lewis, Richard Rosa, Jenny Sabin, and Jim Williamson, who spiced the broth with their insightful

contributions. The Department of Architecture and the College of Architecture, Art, and Planning at Cornell generously supported this project with additional funding. And finally, we wish to recognize our colleagues, whose banter and observations can undoubtedly be seen percolating throughout these pages.

*The Language of Architecture* proposes that architecture functions in ways that are as complex and informative as any language system, capable of poetics and prosaics, of shouts and whispers, of diatribes and love letters.

Each of the book's twenty-six chapters—suggestive of the number of letters in the English alphabet—represents a principle of architectural design. These chapters are organized into eight sections that involve the basic elements of the design process, the substances that comprise an architectural project, the devices through which architecture communicates, and its general modes of production.

This is a visual resource for anyone interested in architecture, featuring the works of well-known architects throughout history, and referencing architecture from ancient times to present day, illustrating the basic tenets of design in the built environment. The text and visuals explain essential elements of architecture through the voices of practitioners and educators.

*The Language of Architecture* is the definitive resource on architecture design fundamentals.

Also available:

*The Language  
of Graphic Design*

978-1-59253-825-6



*Universal  
Methods of Design*

978-1-59253-756-3



*Design for Information*

978-1-59253-806-5

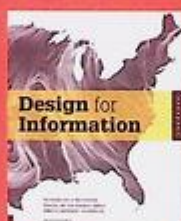

ISBN: 978-1-59253-858-4  
\$40.00 US | £30.00 UK | \$44.00 CAN  
Visit [QuartoKnows.com](http://QuartoKnows.com)

Follow us on     