

Building and construction materials

Flanders: land of bricks and mortar...

People say that Belgians are born with a brick sitting in their stomachs.

Yet, judging by the range of building materials featured in this publication, things may get a little cramped in the average citizen's digestive system, what with all the other materials Flanders has on offer.

These often are innovative products and construction technologies that are adaptable and responsive to the changing needs of home owners as to their comfort, safety, health and living environment or to the pressures on the built environment (energy efficiency, environmental sustainability...).

This sourcing guide offers an unrivalled product mix: aggregates, bricks, pavers, flags, roofing materials, precast concrete elements, steel building components, access flooring, cladding, fibre cement products, concrete formwork shuttering, drainage systems, reconstructed and engineered stone, composite concrete floors, hollowcore slab production equipment, masonry and concrete reinforcement...

By no means does this guide pretend to offer a complete and exhaustive listing of all Flanders-based suppliers of each of the products under review.

Not by far... In fact it is only meant to be a first "instalment" of what is bound to become your definitive guide to sourcing suppliers of high-performance building materials from Flanders.

Do check www.flanderstrade.com for regular updates and order your - fattened up - print version there.

Still not found what you are looking for, though? You require in-depth information on construction and building materials or technologies "made in Flanders" or would like to have more details on building-related partnering meetings?

At the end of this publication, both sections "*Meet the builders... at the building events in Flanders*" include details of construction-related organizations committed to providing you with the right answers and where to meet up with them.

Obviously, you may also rely on the solid foundations provided by Flanders Investment & Trade.

Flanders Investment & Trade

Flanders Investment & Trade

Flanders Investment & Trade, the agency appointed by the Flemish Government to play a pivotal role in its international economic policy, is well-positioned to be your reliable partner.

We can help you source quality suppliers, regardless of the sector in which you operate.

You may also call on us in your quest for partners for joint ventures, technology transfers and other partnership projects.

Or maybe you are looking to set up or expand operations in Europe?

For assistance in establishing production or research facilities, contact centres, logistics operations... in the heart of Europe, come and talk to us.

Or better still, have us come to you.

With over 90 offices worldwide we are bound to be conveniently located near you, wherever you are.

Pay a visit to our website and discover our worldwide network.

FLANDERS INVESTMENT & TRADE

Gaucheretstraat 90 | B - 1030 BRUSSELS

T +32 2 504 87 11 | F +32 2 504 88 99

info@fitagency.be |

www.flandersinvestmentandtrade.com





Building plastics

1. Skylights and rooflights

The *Skylux*[®] range of ATG-certified skylights is available in no fewer than 150 sizes and literally thousands of configurations, depending on its shape (square, round, curved, pyramid, etc.), set-up (single, double, triple-skin), materials used (PMMA or polycarbonate), glazing options (clear translucent, opal, or heat-shielding heatstop-skinned, super insulating (EP)).

Various base curb/upstand options are available (with an integral base curb, an adaptor curb, a permanent vent curb or a corrugated sheet curb...) and they can be fitted with various types of control mechanism (for use as a roof access hatch or for ventilation purposes).

Innovations: the *Cintramax*[®], *Skymax*[®] and *Skyvent*[®]) *SHE* rooflight range, designed for smoke and heat exhaust ventilation (SHE) applications, in compliance with the relevant Belgian NBN S 21-208 standard and forthcoming European fire-safety standards. The energy-efficient *EP* range combines double-skin glazing with an insulated curb, achieving a U-value as low as 1.2, in compliance with current energy conservation standards.

The *Skybeam*[®] tubular skylight system for flat and pitched roofs consists of a roof-mounted PMMA skylight, connected to highly reflective tubing and a ceiling diffuser, designed to maximize light transmission.

Integrated light fittings, ventilation and light-attenuating damper models are available.

The *Cintralux*[®] range of self-supporting, easy-to-install, low-profile barrel vault rooflights, comes in many glazing options (GRP, solid, multiwall, clear, opal, Coolgreen, double or triple-skin), as a fully built-up system with aluminium glazing bar support centres or as a carport kit.

The range also includes high-specification rooflights complying with EU safety regulations (prEN 1187 - fire testing on roofing systems) or the 1200 Joule body impact resistance standard.

The *Polyprofil*[®] range of weather and shock resistant, through-coloured roof edge trims, provides a professional finish to flat roofs covered with roofing membranes. *Evaco*[®] high-strength GRP composite gutters (square or half-round gutter profiles, corrosion and frost resistant, maintenance-free, with a broad range of accessories: brackets, stop ends, running outlets)

2. Conservatory glazing and roofing

Pergolux[®], a complete profile system for conservatory roof build-up on a timber batten or an aluminium frame support structure, glazed with twin to quad-wall acrylic or polycarbonate sheeting. *Clicksy*[®], *Climax*[®] and *Climalite*[®], fully built-up and self-supporting aluminium conservatory roof systems for various roof types (shed, gable...).



AG.PLASTICS QUALITY

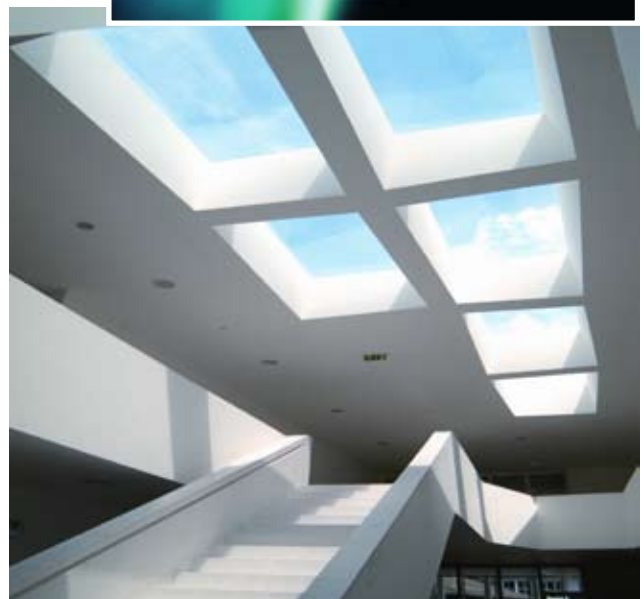
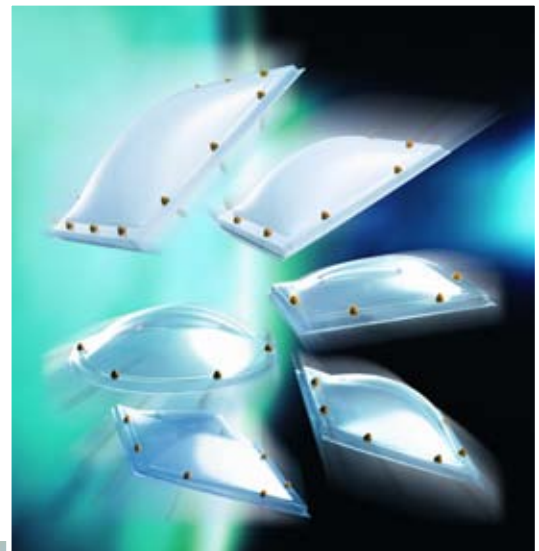

AG. PLASTICS

3. Translucent sheeting materials

Supercristal[®] brand of highly translucent GRP sheeting for flat and profiled in-plane rooflighting.

More... licensed distributor of translucent sheeting materials (single and multiwall polycarbonate and acrylic, PVCu, polyester) and polystyrene and of translucent PC cladding elements

® *Skylux*[®], *Skybeam*[®], *Cintralux*[®] (rooflights and barrel vault domes); *Polyprofil*[®] (roof edge trims) and *Evaco*[®] guttering; *Pergolux*[®], *Clicksy*[®], *Climax*[®], *Climalite*[®] (conservatory and veranda construction); *Supercristal*[®] (flat and profiled GRP sheeting).

🌐 Austria, Bulgaria, Croatia, Estonia, France, Germany, Greece, Hungary, Italy, Latvia, Lithuania, the Netherlands, Poland, Portugal, Slovakia, Spain, Sweden, Switzerland, UK, Ukraine

🇮🇪 Ireland, Denmark, Czech Republic, Slovenia, Serbia, Morocco, US, UAE

📍 Importers and distributors of building and roofing materials, specialist builders' merchant trade

🏠 Bau (Munich), Batimat (Paris), Bouwrelatiedagen (NL), Dach und Wand (Stuttgart), Industrie- en Projectbouw (Antwerp), Polyclose (Ghent), Novibat (FR)

🏭 *AG. Plastics* is a leading manufacturer and distributor of a vast array of building plastics. Leading the market not just in Belgium, but increasingly making a name for itself on foreign markets, it carries some of the largest stocks of glazing and building plastics in Europe.

Some of the prime innovative product developments are the *Heatstop*[®] heat-shielding technology, the patented decorative dome cap concealed fixing system, the smoke and heat evacuation (*SHE*) systems and the energy-efficient *EP* skylight range, with improved heat flow rate (U-value) and insulation level, conforming to the most stringent energy-efficient building standards.

The company's systems have been rigorously tested and come with authoritative, independent certification (ATG, CEPT, EN...,) and broad guarantee coverage (10 years on optimum translucence, up to 20 years for hail-proof properties).

Its commitment to high levels of customer service, delivery excellence and innovating product development has won the company numerous residential and commercial references for its day lighting systems.

🏠 Residential, public access, industrial, commercial and office buildings



AG. PLASTICS

Spinnerijstraat 100 | B - 8530 STASEGEM

T +32 56 20 00 00 | F +32 56 21 95 99

info@agplastics.com | www.agplastics.com

Lightweight precast concrete floors

The patented *Airdeck*® flooring system consists of a precast lattice girder permanent formwork, fitted with weight-saving polyprop airboxes, precision-positioned by robot in a roster-like fashion, acting as void forming hollow elements in the subsequent in-situ concrete topping and creating a robust monolithic concrete floor.

The *Airdeck*® system yields considerable advantages to multi-storey building schemes:

- It requires a lighter structural frame and fewer columns and beams by reducing the floor slab's self-weight by up to 35%, compared to regular precast concrete floors.
- It allows larger clear spans (up to 14m x 14m) and slender, but equally strong, concrete structures with maximum unobstructed floor space and exposed fair-faced soffits.
- It adapts to any layout and offers full architectural design freedom: slab sizes and shapes are factory-made to customer specification, with maximum dimensions up to 4m x 10m, 4 different overall floor heights (280 mm, 340 mm, 390 mm and 450 mm), with service openings for ducts, conduits and cabling or with the *Airdeck*® *Thermo+* fabric energy storage (FES) system embedded in the concrete core, a sustainable alternative for air conditioning.
- It allows up to 50% savings in overall construction costs and optimizes maximum available storey height due to a reduced overall finished floor depth.
- It achieves resource-effectiveness by reducing the use of raw materials (gravel and sand aggregates) and by using recycled/recyclable plastics in manufacturing the airboxes.
- It requires lesser volumes of poured concrete, reduces transport movements, allows for just-in-time deliveries and high-speed installation on site.

AIRDECK®

L I C H T G E W I C H T V L O E R E N



AIRDECK



Airdeck®, *Airdeck® Thermo+*



the Netherlands



Europe, Australia, New Zealand, the Philippines, Norway, Canada, Brazil, Singapore, China, Japan, UAE, South Africa



Precast concrete floor manufacturers, architects, specifiers and consulting engineering firms



As an exhibitor: Betondag (Brussels, Rotterdam), Beton-Tage (Neu-Ulm), Batibouw (Brussels Innovation forum on sustainable FES systems), Bouwbeurs Utrecht (participation by distributor)
As a trade visitor: Construtec (Madrid), The Big 5 (Dubai)



The *Marmorith Betonindustrie* company has traded in the precast concrete industry for 40 years, particularly as a leading manufacturer of precast concrete floors.

A pioneer of sustainable aggregate replacement or reduction schemes for the concrete industry, the company combined its unrivalled in-house experience as a precaster with a constant drive for innovation to design, develop, engineer and manufacture (on a purpose-built, fully-automated manufacturing line) the innovative *Airdeck®* lightweight flooring system.

The system is KOMO-certified by KIWA (NL) and has been successfully specified for an ever-growing list of prestigious national and international reference projects: University College (Utrecht-NL), Virga Jesse Hospital (Hasselt-B), Shell International Chemicals New Technology Centre (Amsterdam-NL)...



Multi-storey project market: residential (high-rise buildings, lofts...) industrial and commercial (office space, car parks...), public utilities (residential care homes, healthcare and educational facilities...)

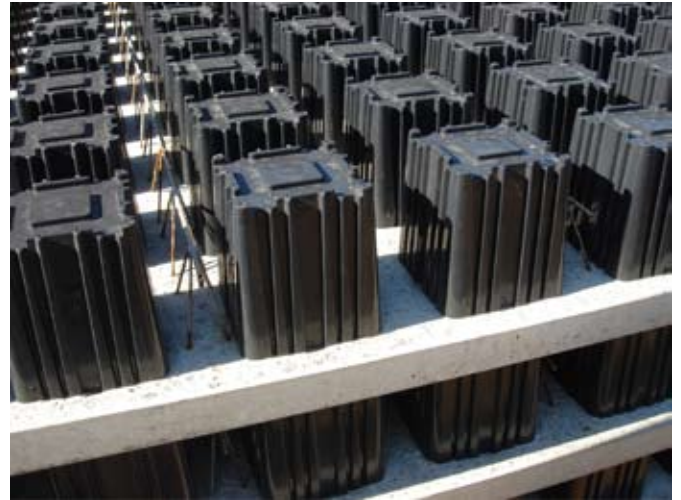

AIRDECK

Molenweg 41 | B - 3530 HOUTHALEN

T +32 476 57 23 40 | F +32 11 45 39 52

airdeck@bouwteamhouben.be | www.airdeck.be

ALCOTILE - GV PRODUCTS



Tile-effect lightweight steel roofing panels

Alcotile lightweight roofing tilesheets are suited for all types of roofs down to 7° pitch. Apart from their outstanding performance characteristics, like exceptional durability and weather resistance, low maintenance, ease of installation and reduced on-site labour, inhibiting moss and lichen growth..., the major advantage *Alcotile* panels have over competing roofing materials (clay or concrete rooftiles) is their reduced weight: weighing a mere fraction of traditional rooftiles (5 to 7 kg/m², depending on panel type), they allow for lighter roof substructures.

As a result, they are ideally suited for reroofing jobs, flat-to-pitch conversions and over-roofing cladding applications and do not require any preparatory demolition work of existing roof coverings with tiles, slates, profiled sheeting or waterproofing membranes.



total top tile!



Deck cores to all sheets are made of high-quality alu-zinc alloy coated steel sheet with a 0,5 mm thickness and are given a UV and weather-resistant surface coating (pearl or satin finish) on a standard array of 10 appealing colours: grey, red, terracotta and brown (natural or rustic finish) and green and black (high-gloss finish).

Non-standard, factory-approved colours are available on demand.

Broad range of complementary accessories in matching shades and finishes: eaves and barge flashings, bargeboards, translucent tiles, angle ridges, barrel ridge and end caps, gas flue and venting tile elements, valleys...



Alcotile, Alcotile Plus, Alcozinc, Romatile



Austria, Belgium, France, Germany, Italy, Spain, Switzerland, the Netherlands, USA



Czech Republic, Denmark, Estonia, Finland, Ghana, Hungary, Latvia, Liberia, Lithuania, Norway, Russia, Sierra Leone, Sweden, Turkey, UAE

Apart from the classic *Alcotile* tilesheet, the range further includes the *Alcozinc* tilesheet (made of 100% pre-weathered zinc), the *Alcotile Plus* sheet, with innovative twin deck core panel build-up and improved sound-proofing properties and the latest addition, the 2006 *Romatile*, a mediterranean-look Roman rooftile.

The entire range holds Belgian technical ATG agrément (ATG 06/2693) and is covered by a 30-year warranty.



ALCOTILE - GV PRODUCTS



Builders' merchants, roofing materials wholesale trade, specialist roofing contractors, specifiers, architects, project developers...



Batimat (Paris), Internationale Bouwbeurs (Utrecht), Batibouw (Brussels; participation by approved dealers and contractors)



Drawing on over 20 years' experience as a Benelux distributor in the lightweight roofing materials business, in 2004, *GV Products* decided to launch into manufacturing its own *Alcotile*-branded line of tile-effect roofing panels. Its state-of-the-art factory, equipped with up-to-the minute cutting, pressing and powder-coating technology, now has an annual manufacturing capacity of 900 000 tilesheets. Since manufacturing started, *Alcotile* roofing systems have been successfully applied in new-build and refurbishment schemes across Europe and beyond (like the *Alcotile* reroofing project on the Liberian president's residential mansion). Another high-profile reference is *GV Products*' sole supplier status of "own-label" lightweight tilesheets to the globally operating *Onduline* roofing materials group.



New build and refurbishment schemes in residential, private housing and commercial project markets



ALCOTILE - GV PRODUCTS

Bilzersteenweg 43 | B - 3770 RIEMST

T +32 12 44 14 44 | F +32 12 44 14 45

info@alcotile.be | www.alcotile.be



Precast structural concrete building elements

Included in the portfolio are: precast concrete foundation or footing elements, beams, columns, stairs, inner leaves, wall panels, stadia elements, balcony units and a wide range of bespoke structural precast concrete units up to 25m and 30-tonne size limits.

The company has also developed a number of innovative, factory-manufactured, built-up systems like the *Comfort Wall®* panel, consisting of a precast concrete outer leaf with an interior drywall plasterboard lining, ready for final decoration.

This system provides a rapid and cost-effective building solution for any construction scheme (even low-energy building concepts): manufactured in a quality-controlled factory environment with just-in-time delivery to site for swift erection, the system comes with preformed door and window apertures, services openings and preinstalled utilities and ducting, reducing on-site labour and follow-on trades.

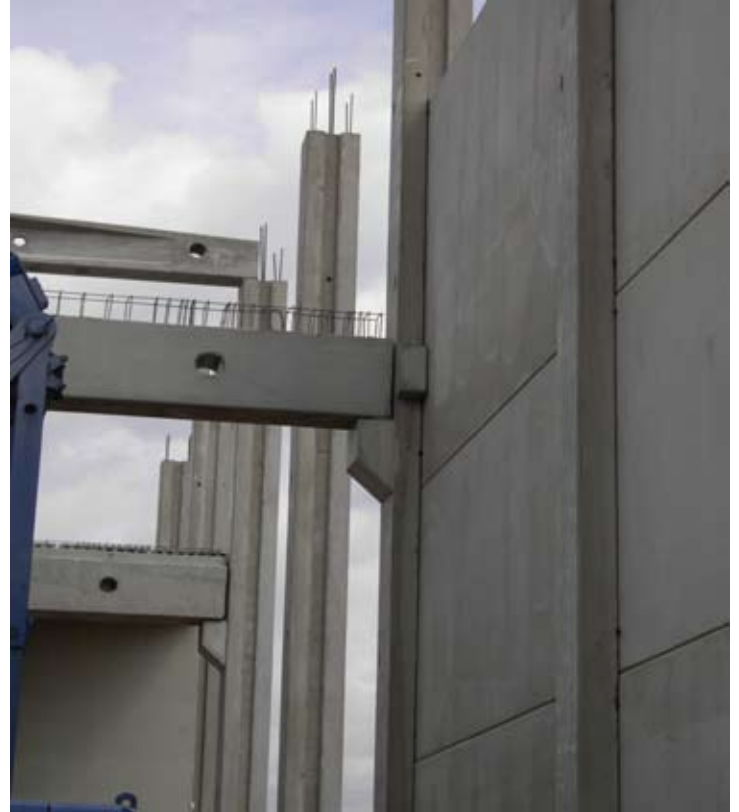

ALTAAN

PREFAB BETON



France, the Netherlands, Luxemburg



China, Vietnam



Building contractors



Regular trade visits to: Bauma and Bau (Munich), Internationale Bouwbeurs (Utrecht)...



Drawing on 20 years of expert experience as a precaster, *Altaan Beton* has developed into a leading supplier of structural precast elements for industrial, commercial and residential construction applications.

From the earliest design stages of the most complex projects, an in-house expert team liaises with architects, consulting engineers and main contractors in order to devise the best possible engineering solution.

The company boasts numerous finished reference projects as trusted supplier of structural precast elements to major building contractors, operating internationally on commercial, industrial and other high-profile building and engineering projects.



Altaan Beton is a member of *Flanders Concrete* cluster of concrete processing companies (www.flandersconcrete.com).



Residential, industrial and commercial projects (utilities, road building, hydraulic engineering...)

ALTAAN

Siemenslaan | B - 3650 DILSEN-STOKKEM
T +32 89 65 13 30 | F +32 89 65 13 31
info@altaan.be | www.altaan.be



Light expanded clay aggregates

The range includes:

- lightweight bulk aggregates, available in a wide variety of pellet shapes (granular, mixed or crushed), sizes (0/2, 0/4, 2/5, 4/8, 4/10, 8/16) and densities (300 kg/m³ up to 750 kg/m³);
- structural lightweight concrete, screeds and insulating subscreeds;
- manufactured spin-off building products: lightweight insulating concrete blocks for structural building and a range of other lightweight concrete products: beam- and-block roofing and flooring systems, precast concrete chimney sections, refractory concrete products and mortar, sound-absorbing walls, prefab elements...
- Lightweight backfillings for civil and hydraulic engineering applications (road building, water management...)



Argex, Topargex, ArgeMIX



Germany, France, UK, Benelux



Market development effort ongoing in: Ireland, Greece, Portugal, Spain, Turkey, Bahrain, Qatar, UAE, Scandinavia...



The ready-mixed and precast concrete industry, major builders' merchants wholesale trade



Batibouw (Brussels), Betondag (Brussels and Rotterdam), Archipro (Liège-Belgium), Industrie-en Projectbouw (Antwerp)



For over 40 years now, the Argex company has produced high-quality expanded clay aggregates. Every day, about 1,000 tonnes of clay is conveyed from the company-owned quarry to its purpose-built plant operating Europe's largest rotary kiln for the manufacture of the lightweight pellets (maximum annual capacity: ½ million m³).

Ideally located at the intersection of the Antwerp ring road and the river Scheldt, the company exports about half of its total output from its own quayside ship loading facilities.



Argex expanded clay aggregates offer a number of undisputed benefits over competing materials: an environmentally-friendly, all-natural material, utterly lightweight, with proven thermal and acoustic insulating properties, high compressive strength, hardwearing, fire-resistant and rot-proof.

Its applications, featuring mainly in the construction and the horticultural industries, are astoundingly versatile: as a weight-saving building material, a structural or non-structural aggregate for concrete and screed, as a material used for backfilling, in stormwater soakaway, infiltration and attenuation systems, in biological water treatment plant, soilless plant cultivation or for landscaping purposes (as a substrate aggregate, a drainage or moisture-retention material in urban green areas, sporting grounds, green roofs, roof gardens...)

Stringent quality and performance monitoring in compliance with ISO 9001-2000 guidelines, product accreditation (CE, KOMO, Dutch Construction Materials Decree, Weihenstephan Horticultural Research Institute standards).

Various pack and delivery modes: bagged and palletized, in big bags, tanker truckloads for swift delivery on site or full or part shiploads.

Comprehensive technical support, continuous R&D effort and innovative product development: e.g. *Argex*-based sustainable water management solutions or the pumpable ready-mixed lightweight concrete, successfully tested in a laboratory environment by the Belgian Building Research Institute and on various pilot building sites).

Many site references across Belgium, the Netherlands and France of *Argex* products in a broad array of applications.



New build or refurbishment projects in both the residential and non-residential construction markets, civil and hydraulic engineering.



ARGEX

Kruibeeksesteenweg 227 | B - 2070 ZWIJNDRECHT
T +32 3 250 15 15 | F +32 3 250 15 00
info@argex.be | www.argex.be

BEKAERT BUILDING PRODUCTS



Steel fibre and wire-based reinforcement products for the construction industry

Comprehensive portfolio of proprietary steel fibre and wire-based reinforcement products for the construction industry, including:

Dramix®, high-performance steel fibres for reinforcing concrete (cast in-situ and precast) used in the following applications:

Flooring: industrial and jointless floors, suspended floors-on-piles, fluid-tight floors and composite metal decks.

Housing : foundation slabs, screeds, floors exposed to moderate loads, cellars, various concrete foundation designs (strip, trench fill, piling...)

Heavy-duty pavements exposed to intense traffic overrun and high impact (quaysides and container stacking areas, aircraft pavements, runways, taxiways, access roads, road building and rehabilitation...)

Precast concrete elements: wall panels, pipes, pre-fabricated transformer cabins, garages, stormwater tanks, inspection chambers, prestressed concrete beams...

Tunnelling applications: shotcrete final linings, segmental linings (TBM)



The CE-marked **Murfor®** masonry reinforcement provides an optimum crack control solution, both technically and economically, for loaded brick and blockwork. It improves the masonry's structural performance and substantially reduces crack patterns. **Murfor®** fully complies with Eurocode 6 (masonry structures) and Eurocode 8 (earthquake-resistant structures).

Murfor® is embedded into the bed joints of the brickwork, increasing the overall compressive and tensile strength levels within the masonry wall, its bonding properties and its resistance to cracking, brought on by dimensional changes in the brickwork (load-induced movement, bending or shear, creep and foundation settlement, vibration...).

Murfor® is typically used in ring beams, brickwork lintels, cavity walls, strengthening unbonded masonry, absorbing concentrated loads and stresses, soil pressure, exposure to lateral wind loads and differential settlements. It also extends spacing between movement joints and increases the in-plane and out-of-plane behaviour of infill walls.

 **BEKAERT**
better together



BEKAERT BUILDING PRODUCTS



Wire-based reinforcement products for the wet trades:

Stucanet[®] galvanised steel wire lath carrier for rendering and plastering of internal and external walls with gypsum, cement and lime mortars;

Widra[®] corner reinforcement beads for external renders;

Armanet[®]: reinforcement mesh for repairing cracked brickwork, as a plaster carrying support for external wall insulation systems;

Poutrafil[®] welded wire studs used for constructing structural frames for light walls, ceilings and arched construction elements;

Bitufor[®] road reinforcement system, consisting of flexible woven steel netting, mesh track combined with a slurry sealing membrane. **Bitufor**[®] increases the loadbearing capacity of under-designed flexible roads and provides effective control of reflective cracking in pavements, making it ideally suited for heavy-duty road reinforcement or rehabilitation and for overlay resurfacing of existing concrete and asphalt-surfaced roads.



Dramix, Murfor, Stucanet, Widra, Armanet, Poutrafil, Bitufor



Worldwide presence



Continuing technological leadership and worldwide marketing effort



Concrete manufacturers, general building contractors, precast concrete industry, engineering firms, specifiers, architects, importers, specialist distributors



Bekaert Building Products is a "fixture" at all major construction fairs of global renown



In selected applications of its two core competences, advanced metal transformation and advanced materials and coatings, *Bekaert* develops a vast array of high-tech products, systems and services for customers in various sectors. The company is a genuine global player, with 70 production plants worldwide generating sales of € 3,1 billion, employing 17 000 people in 120 countries.

The company's building products division manufactures and markets a hugely varied range of proprietary steel fibre and wire-based reinforcement products for the construction industry. All of its advanced specialty building products are made to the most stringent technical building standards and regulations, are rigorously tested and bear multiple certification by the most authoritative national and international certifying bodies.

The company is unremittingly committed to a policy of R&D and solutions-driven innovative product development, in close partnership with customers in the global construction industry, which it provides with comprehensive technical, engineering and commercial support.

Its dedicated, multi-language website features an unparalleled amount of downloadable technical data sheets, manuals, calculation tools, reference project testimonials...



Industrial and logistics building construction, public works and utility projects, housing...



BEKAERT BUILDING PRODUCTS

Bekaertstraat 2 | B - 8550 ZWEVEGEM

T +32 56 76 69 86 | F +32 56 76 79 47

Catherine.Deprez@bekaert.com | www.bekaert.com/building

BELTRAMI



Natural stone wholesale

Huge standard range of granite, marble, slate, basalt, limestone and sandstone varieties for interior and outdoor applications: flooring, tiling, cladding, kitchen worktops, office desktops, vanity units, hard landscaping, paving, kerbing, patio areas, pool surrounds...

The multiplicity of stone formats include slabs, tiles, paving stones, pavers, cobblestones, strips, cladding elements, random lengths, insets, skirtings/plinths, palissades..., available in a broad standard range of dimensions (with some varieties even allowing custom dimensions) and a common standard 20-30 mm thickness.

Beltrami tiles are calibrated to thickness and come in an unparalleled choice of both traditional surface finishes (sawn, diamond-sawn, honed, polished, bush-hammered, chiselled, brushed, flamed, tumbled, hand- or machine-cleft, split-faced...) or with a special "artificially aged" finish (antico, brossato, rustico, sablino, satino, versailles vieux manoir, enostyl-antiqued...).

Uniquely innovative are the *Beltraline* range of thin calibrated tiles (just 10 to 17 mm in section), adhesive-fixed onto an existing floor or a screed substrate or used for wall tiling, the *Beltralinea* range of flooring and wall cladding strips, the appropriately-named *Woodstone* line, capturing the wood grain look of parquet flooring, the easy-to-apply *Stoneskin* cladding elements, consisting of polyester resin bonded strips of natural stone, providing a true-to-nature dry stonewalling effect along or Beltrami's appealing *Garden* outdoor range.

Complementary range of ancillary products and consumables: admixtures, adhesives, jointing materials, coating, cleaning, maintenance and protection agents...

More: *Trafficstone* engineered conglomerate stone tiles for indoor applications



Beltrami, Beltraline, Beltralinea (Stoneskin, Woodstone, Garden), Trafficstone



UK, Benelux, Germany, France



Poland, Ukraine, Estonia, Latvia, Lithuania, Russia



Batimat (Paris), Budma (Poznan), Coverings (Orlando), Interbuild (Birmingham), Kamien (Wroclaw), Marmomacc (Verona), Mosbuild (Moscow), Natural Stone Show and Tile and Stone Show (London), Nordbat (Lille), Stone + Tec (Verona)



Beltralinea Ardesia Nera Stoneskin (project by Conix Architects)



Beltralinea Woodstone Wenge

BELTRAMI



Tile retailers, paving and flooring contractors, builders' merchants, stonemasons' cash&carry outlets, importers/distributors, stone fabricators, landscapers, interior designers



In just over 20 years, the Beltrami company has grown into a widely respected natural stone wholesaler with a proven reputation as an innovator and prime promotor of natural stone as a timeless architectural building material



Internationally, the company has gone from strength to strength, with buoyant exports and 4 sales offices (UK, Poland, the Netherlands, Italy) currently in operation.

Tremendous stock levels are held at its 2 Belgian warehouses, covering a total of 30 000 m² - with some extra stocking capacity at its UK branch – and shipped across Europe by its fully-owned logistics fleet, guaranteeing tight delivery schedules.

Stringent quality monitoring: Beltrami products are ethically sourced from screened suppliers (local quarry operators, stone fabricators...) across the globe (Italy, Spain, Portugal, France, China, Brazil, Vietnam, Iran...) and subjected to rigorous testing : e.g. the entire outdoor range bears the CE mark and has been tested to European standard requirements EN 1341, EN 1342, EN 1343.

True to its well-earned reputation as an innovator and a promotor of exciting new natural stone finishing solutions, the company is as regular as clockwork when it comes to introducing newly-sourced materials, novel finishes and innovative formats (Beltraline, Beltralinea Woodstone, Stoneskin, Garden...)

Furthermore:

- top-of-the-line stone-processing machinery and tile finishing equipment and an impressive showroom with the entire Beltrami stone range on view, showcased to its best advantage;
- regular commissions and competitions organized for architects, interior designers, contractors... specifying new Beltrami products for their projects;
- comprehensive technical guidance: 7-language website, containing highly informative product literature, downloadable technical data sheets, product specification, detailing aids and selector tools, reference projects, electronic newsletter...



Residential and commercial projects: interior design, fitting out, flooring, cladding, hard landscaping...

BELTRAMI

Politieke Gevangenenstraat 40 | 8530 HARELBEKE

T +32 56 23 70 00 | F +32 56 23 70 02

info@beltrami.be | www.beltrami.be



Beltralinea Antalya Cream - cleft



Natural stone agglomerate paving flags

Natural stone agglomerate paving flags for outdoor hard landscaping applications (driveways, terraces, stairs...)

All of *BJA's* flags (with a standard size of 400 x 400 x 40mm) have proven anti-soiling properties, are low on maintenance, frost and skid resistant, seal-coated and come with a non-fade guarantee.

Available in a range of colours (up to 21 hues for its main *Granitolux* brand) and finishes (round, brushed, sandblasted, acidified, slate-textured), they also allow diverse laying patterns (e.g. circle packs allowing a 1 to 6-ring circular design with squaring-off and bonding-in kits for easy installation within a surrounding paving design).

More... complementary array of hard landscaping elements (garden edgings, outdoor step paving, planters, garden lighting posts, mailbox pillars, paving supports, graded jointing grouts...)



Granitolux, Structuro, Cirko & Carré, Grindo



The Netherlands, France, Germany, Luxembourg, UK, USA, Switzerland



Ireland, UK, Austria, Denmark, Sweden, Switzerland, US, Japan



Agents operating in the gardening and landscaping part of the market, specialist wholesale trade (garden centres, builders' merchant trade...)



Nordbat (Lille)



Drawing on 30 years' experience, *BJA* has developed an encompassing portfolio of natural aggregate paving slabs, ¾ of which are destined for export.

Backed by a rigorous quality monitoring policy, the company's highly-skilled staff operates state-of-the-art stone-processing equipment, converting prime-quality aggregate blends into high-quality tiles with embedded natural stone chips, adding



aesthetic appeal to traditional, conservation and contemporary landscaping schemes alike.

Extensive complementary product array of matching garden and patio products; made-to-measure product development is a definite option.

Swift and efficient order and delivery service from a vast stock, excellent record of technical and commercial support provided to customers and specifiers.

Member of the Flanders Concrete cluster of concrete-processing companies (www.flandersconcrete.com)



Residential, domestic and light commercial applications



BKA

Brabantsestraat 21 | B - 3570 ALKEN

T +32 11 31 22 37 | F +32 11 31 64 88

info@bka.be | www.bka.be



Suspended ceiling systems for the project market, to be clad with a choice of interchangeable tiles and fully integrated lighting modules

Ceilux's two ceiling systems (Lay-in and Clip-in) open up the possibility for architects to indulge their creativity. This manufacturer's concept centres on the key words of choice, simplicity and mobility.

Depending on the suspension system chosen architects are offered a choice of (pre-powder coated thermo galvanized steel or thermally shaped plastic) tiles:

- 585 x 585 mm Lay-in drop panels (optionally perforated);
- 585 x 585 mm Lay-in stretch tiles (optionally installed with a white or black insulation mat);
- 600 x 600 mm or 300 x 1200 mm Clip-in tiles (optionally perforated). All perforated panels are provided with an acoustic membrane, tested in accordance with ISO 354-1985.

Complementary to the above range are the (identically sized) panels with integrated (pre-cabled) lighting modules covering various lighting needs. Whether we are talking direct lighting, basic lighting, wallwash or accent lighting, it suffices to simply insert the plug into a pre-installed socket.

Mobility is a major forte of *Ceilux's* systems. If the function or interior of a room changes over time, the tiles and lighting modules can simply (& cheaply) change position, without the need to have the suspension system adapted.

Ceilux's ceiling systems are also applicable for walls. Edge finishing profiles are available for all applications.

Ceilux

Benelux, Poland, Russia, Dubai...

Israel, Lithuania, UK, Saudi Arabia, Sweden, Norway, Ireland

Importers, wholesale trade

Nordbat (Lille), Architect@Work (Courtrai-Belgium), Bati-bouw (Brussels)

Since its start-up in 1998 *Ceilux* has invested in project related support services, which in turn has boosted the company's commitment to innovative design and installing techniques.

As a result *Ceilux* now boasts an impressive list of references within Belgium, as well as customers in the United Arab Emirates, Russia, Poland, France and the UK.

Project market: offices, commercial areas...



CEILUX

Vloedstraat 10/4 | B - 8800 ROESELARE
 T +32 51 20 75 07 | F +32 51 20 27 02
www.ceilux.com | info@ceilux.com



Self-levelling cementitious sub-floor smoothing compounds and floor screeds

The extensive range of cementitious powder and water-based compounds and screeds by *Cemart* are used for the following applications:

- as an underlayment for levelling and smoothing out the subfloor and allowing it to be covered by various types of floorcoverings;
- as an attractive decorative floor finish (*Cemstyle* range) in stylish interiors and settings of contemporary design

Self-levelling screeds are effortlessly flow or manually applied to any thickness ranging from 1 to 50 mm, depending on the type of compound and its application. The screed range comes with a broad array of complementary coatings, sealants or admixtures, providing them with improved mechanical and chemical resistance properties (quick drying, wear, scratch and skid resistance or to acid and chemical attack, heavy vehicular overrun, impact, fibre-reinforced... or with specific aesthetic surface characteristics (coloured toppings, extra smooth finish...)

More... cementitious floor finishing coatings, patching mortars and concrete repair mortars



Cemdure, Cemfort, Cemtop, Cemstyle, Cemfix, Cemcoat, Cemcolour, Cemprime



UK, Iceland, Ireland, Bulgaria, Czech Republic, the Netherlands, Sweden...



France, Italy, Germany, the Baltic States...



Distributors, builders' merchant wholesale trade, DIY retail trade (for patching mortars and concrete repair mortars range only)



Foreign trade fair participation envisaged (Futurallia-FR)



Drawing on 20 years of combined technical experience in the manufacture and application of self-levelling floor screeds, *Cemart's* rigid quality monitoring, durability testing and constant drive for innovation and product improvement has earned it preferred supplier status of cementitious flooring solutions in an ever-growing number of high-visibility industrial, commercial and residential building and refurbishment projects.



Public utilities, the industrial, commercial and residential markets

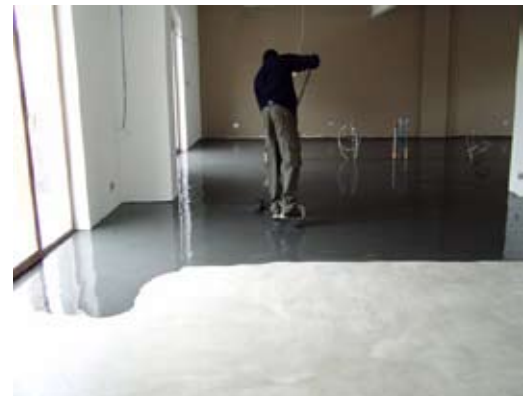

CEMART

Maatheide 76e | B - 3920 LOMMEL
 T +32 11 52 51 10 | F +32 11 52 51 09
 info@cemart.be | www.cemart.be



Modular concrete panel shuttering systems

Design, manufacturing, marketing/hiring of modular concrete panel shuttering systems (for wall, column, beam shuttering, slab formwork, precast and architectural concrete...);
 Custom shuttering moulds for precast concrete formwork;
 Turn-key shuttering projects.



Cometal (Alcom, Bimet, Cicom, Altor, Horad)



The Netherlands, Luxembourg, Ireland, France, with occasional exports to other markets



Ongoing marketing effort in the Netherlands and a number of other European countries



Trade intermediaries: distributors, rental firms
 End-users: concrete and structural building work contractors, manufacturers of precast concrete elements



Bauma (Munich), Matexpo(Courtrai-Belgium), Betondag (Brussels), Betonvakdagen (Gorinchem-the Netherlands)



Since it introduced its patented light-weight modular aluminium shuttering system in 1984, *Cometal* has made a name for itself as the sole Belgian manufacturer of innovative concrete shuttering systems, supplying a broad range of standard and bespoke shuttering systems and moulds for precast and on-site casting.

Major assets:

Fully-owned and independently operated manufacturing plant, in-house R&D, system development, engineering and manufacturing, allowing for highly-specified customized commissions;

Innovative product development and regular prototype roll-outs: e.g. the unique *Bimet* steel wall shuttering system for seamless architectural concrete, allowing a top grade "high construction flair" surface finish in line with the most stringent technical requirements on surface assessment of concrete (NEN 6722)

Service delivery excellence: close early-stage involvement in high-profile engineering projects, comprehensive technical on-site support, proven expertise as a reliable rental services provider, endorsements from an ever-growing number of international concrete engineering and construction firms;



Structural building work in both the residential housing and the industrial and utility infrastructure markets (industrial and office buildings, civil engineering, road building, bridges, tunnels, water-retaining structures...)



COMETAL

Industrieweg-Noord 1129 | B - 3660 OPGLABBEEK
 T +32 89 81 99 00 | F +32 89 81 99 33
 info@cometal.be | www.cometal.be

Shuttering systems for precast and in-situ concrete formwork

- Modular panels or full steel shuttering systems for fair-faced concrete structures;
- Adjustable circular full steel shuttering panels;
- Column formwork in various cross-sections (rectangular, square, circular, oval, adjustable, ...);
- Battery moulds for series of walls, columns and beams;
- Precasting beds : fixed, lifted by overhead crane or hydraulic tilting tables;
- Moulds for precast concrete stairs and landings (in both standard and bespoke configurations)
- Tunnel formwork shuttering systems;
- Carousel and long-line precast systems (fully- or semi-automated production plants);
- Moulds for precast railway sleepers;
- Specialist custom-made formwork for e.g. lighthouse shafts, IV joists, abutments, piers, retaining walls, heated shutters for pipe foundations, electric substations...

Some of the high-precision formwork for precast and cast-in place jobs are available in a modular or pre-assembled set-up, with full steel or timber panelling, with or without hydraulic steering/tilting devices, proprietary formwork accessories, preformed services apertures, access ladders...



Construx



Belgium, Luxemburg, The Netherlands, Ireland



UK, France, UAE, India, Thailand, Vietnam, Mexico



Companies operating in the precast concrete industry and in-situ concrete formwork contractors



Betondag (Brussels/Rotterdam), Bauma (Munich), Matexpo (Courtrai -Belgium)



Ever since it was set up, some 5 years ago, the *Construx* company has grown into a trusted supplier of specialist formwork and shuttering systems, tailored to the most exacting needs of concrete formwork contractors and the precast industry.



CONSTRUX

Backed up by unparalleled know-how of both on-site concrete formwork construction and precast techniques, a dynamic team of experienced and highly-trained draughtsmen, engineers, welders, mechanics and service operatives... systematically manages to design, develop and manufacture fully-customized formwork solutions for contemporary concrete building, allowing unfettered designer flexibility in compliance with latest technical requirements and standards.

Through early stage project involvement, the company boasts an excellent service delivery track record and features as a valued partner with a number of leading players in the concrete business, both precast and ready-mixed. Some high-profile commissions:

Column boxes for on-site use (by Ballast-Nedam-NL)
Precast housing manufacturing plant (by Kooi-NL),
precast column boxes (by Haitsma-NL), production line for fair-faced wall elements (by Prefadim-BE), adjustable column boxes for on-site use (by Van Laere, BE), precast stair moulds (by CRH-BE and McNamara-IE), full steel shuttering panels (by Treacy Builders-IE), complete filigree slab production carousel (by C.F.Structures-IE);

Member of the Flanders Concrete cluster of concrete-processing companies (www.flandersconcrete.com)

Industrial and project markets



CONSTRUX

Centrum Zuid 2411 | B - 3530 HOUTHALEN
T +32 11 63 60 60 | F +32 11 63 60 61
info@construx.be | www.construx.be



Hollowcore slab production lines

Reinforced hollowcore floor slabs barely need introduction: they currently are a widely favoured choice for construction, providing high-strength, adaptable and cost-effective wide-span structural flooring solutions, with the additional benefits of swift on-site erection, excellent fire resistance and acoustic performance and ease of finishing...

Damman Croes has made it its mission to build just the machinery required to allow the cost-effective mass-production of high-quality hollowcore floor slabs. Its highly-automated hollow core production plant operates in a continuous manufacturing process, featuring raw materials handling, batching plant with high-precision dosing, microwave sensor-driven moisture control equipment, feeder hoppers delivering concrete onto casting beds, with concrete divider unit mounted atop, and overhead lifting clamp cranes.

The high level of automation allows output capacities of up to 150m²/h, requiring just two operators.

Fully-computerized process and quality controls, featuring remote-controlled diagnostics and problem-solving supplier assistance, along with real-time dynamic visualisation of the entire manufacturing process, from monitoring the raw materials flow through to the finished product: high-quality, no camber hollow core elements.

These are available in up to 8m slab lengths, 130, 170 and 210 mm depths and 60 cm width and with a smooth, coarse or textured surface finish.

All slabs are manufactured to exact length specifications, so no cutting-to-size is required.

Also included in the range are complete stationary concrete batching plant, equipped with the proprietary *Damman-Croes* planetary 300 to 4500-litre concrete mixers, concrete mixing plant for the precast and ready-mixed concrete industry, concrete crushers for aggregate recycling.

More... High-capacity crackers and flakers for the oil mill, animal feed and breakfast cereals industries



DAMMAN-CROES



Damman-Croes



France, Austria, Czech Republic,
Ireland, United Kingdom...



Eastern Europe, Middle East, Mexico



Operators in the hollow core precast
industry



Big 5 Show (Dubai), Bauma (Munich),
Betondag (Brussels)



With a company history going back
as far as 1872, *Damman-Croes* has
diversified over the decades into one
of its current core businesses, that
of manufacturing equipment for the
ready-mixed and precast concrete
industries, a particular line of busi-
ness in which it now boasts over 20
years of frontline experience.

Highly-skilled in-house engineer-
ing, software development and
design team, top-notch 3D CAD and
state-of-the-art manufacturing and
machining equipment, up-to-the
minute technology watch, continuous
optimization of the manufacturing pro-
cess, customer-specific innovations, full
technical and commercial support and
excellent service delivery.

Environmental concern: crushing, recon-
ditioning and recycling of demolition
concrete aggregate



Industrial markets only



DAMMAN-CROES

Spanjestraat 55 | B - 8800 ROESELARE

T +32 51 20 43 43 | F +32 51 20 93 74

info@dammancroes .be | www.dammancroes.be



Solid timber sectional buildings

Included in the company's offering are the following building types: houses and residential villas, log homes (chalet and bungalow-style), English-style outbuildings, garden conservatories, pool-houses, car ports, garages, stables and barns, sheds, gazebos, community buildings and clubhouses.

Central to the company's building concept are the unique solid timber wall beams (available in 56, 69 and 90 mm thicknesses, with a unique double or triple interlocking system,) factory-made to a high level of prefabrication (with linings, membranes, pre-cut cabling ducts, incorporated services, external joinery...), with various finishing options, both interior (dry-wall plasterboard or solid wall panelling) and exterior (brick-cladding or insulated timber sidings)



The Netherlands, Germany, Portugal, Croatia



Croatia, France, Germany, Italy, the Netherlands, Portugal, Spain



Professional trade intermediaries (contractors, architects, property developers...) with a profound technical sales knowledge of prefab solid timber construction and the ability to organise and coordinate the entire completion of a dwelling (from foundation work to detailed fitting out)



Batibouw (Brussels), International Building Fair (Zagreb)



The *De Backer* company was established back in 1979 as a mainstream carpentry, but it soon diversified into its current line of business as a designer, manufacturer and contractor of solid timber sectional buildings. With an annual average of 300 such houses designed and built,



DE BACKER

the company has market leadership in Belgium. Over the years, it has been securing ever-increasing business volumes abroad.

Design flexibility: besides the extensive range of standard building designs (with a number of fully-finished properties available for viewing at its showhouse facility), the company's professional design and engineering department, operating in a top-notch CAD-CAM environment, also develops a broad range of architectural concepts and building types on a bespoke basis.

Stringent quality monitoring of all materials used: first-grade kiln-dried, Scandinavian, pressure-impregnated, thermally treated sidings and roof components, ATG certified timber construction concept and impregnation technique, thermal insulation requirements complied with (standard spray foam floor insulation, high-insulation glazing...)



State-of-the-art timber engineering and machining: CNC sawing, planing, routing, impregnating ...*De Backer* also caters for the growing self-build business, with local contractors buying a shell construction package to their specification and completing and detailing it themselves under the company's supervision.



Residential, recreational and community amenities



DE BACKER

Winkelaar 1 | B - 2240 ZANDHOVEN
T +32 3 464 04 40 | F +32 3 464 04 41
info@debacker.be | www.debacker.be



Precast concrete components for the railway, utilities and civil (hydraulic) engineering industries

Rail products: prestressed concrete sleepers and crossing bearers, light rail/tramway sleepers, level crossing panels, cable troughs and trackside drainage channels;

Civil and hydraulic engineering products: box culverts (of varying section diameters), retaining walls, cable troughing channels and gullies, shore defence piling and embankment base reinforcements, stormwater drainage channelling sections, soakaway systems...



The Netherlands, France



UK, CEE countries, Northern Africa, China, Vietnam



National railway operators, railway engineering companies, hydraulic and sewerage engineering contractors



Bauma (Munich),
Matexpo (Courtrai-Belgium),
World of Concrete (Las Vegas),
SAIE (Bologna)



Set up in 1951, the *Beton De Bonte* company today prides itself on decades of experience in the design and manufacture of precast concrete components for the rail, civil and hydraulic engineering industries.

Apart from its comprehensive standard range of factory-engineered speciality precasts, the company also offers an impressive array of custom-built construction elements for general civil engineering purposes.

Backed by professional in-house engineering, top-of-the line mould-making, welding and casting units and laboratory testing facilities, the company achieves the highest manufacturing standards, satisfying even the most demanding of customers.

It is hardly surprising therefore that the company should feature as an accredited supplier of concrete components to Belgian, Dutch and French national railway network operators (*NMBS, NS, SNCF*) and major infrastructure management companies and contractors (*Infrabel, ProRail,*



BETON DE BONTE

BAM, Strukton) for a number of high-profile national and international network enhancement and high-speed track development schemes.

In the hydraulic engineering area, custom-built components have been supplied to major world-class engineering companies (*Jan de Nul, Deme Group, Heijmans, CFE/MBG, CEI...*) on projects commissioned by various public utility companies and government agencies.

The company holds comprehensive product and quality assurance certification (compliance with ISO 9001, BENOR, KIWA, Dutch Construction Materials Decree), and is an accredited integrator of the most widely-used proprietary rail fastening systems .

Member of the *Flanders Concrete* cluster of concrete-processing companies (www.flandersconcrete.com).



Rail infrastructure, civil and hydraulic engineering



BETON DE BONTE

Sint-Annastraat 55 | B - 9250 WAASMUNSTER

T +32 52 47 33 20 | F +32 52 47 26 98

dbvh@debonte-vanhecke.be | www.debonte-vanhecke.be

BETON DE CLERCQ



Precast concrete elements...

... for a broad range of underground, above-ground and residential building applications.



Water harvesting and channelling

Catch basins up to 600 m³, manholes and inspection chambers, concrete pipeline systems and accessories, PVC-lined concrete piping, box culverts, embankment base reinforcement and revetment, waterway defense piling, cable troughing, stormwater harvesting tanks and drainage channelling sections, concrete gullies, concrete products for sustainable drainage and infiltration/attenuation systems, retaining walls...

Water and sewage treatment

Concrete precast elements for water treatment systems and fully built-up water treatment plant: oil and grease separators, sludge settlement tanks, washwater reuse systems, small-scale domestic wastewater treatment plant

Road paving and hard landscaping (domestic and public)

Block pavers and flags, kerbing, edge restraint units for roundabout layout, grass reinforcement pavers and flags, tactile and textured paving, road humps, median safety barriers, road restraint, traffic calming and flow management systems...

More... its affiliated *Structo* company is a prominent manufacturer of precast concrete bridge elements, hollowcore flooring systems, beams, trusses, columns... and other prestressed structural concrete elements (www.structo.be)



France, the Netherlands, Germany, Luxembourg...



Marketing channels sought throughout Europe, with a particular interest in Romania, Bulgaria



Civil, hydraulic engineering and road building contractors, water utility companies, environmental authorities...



BETON DE CLERCQ



Tedewest (regional trade fair geared at local government technical departments – Roeselare (Belgium) Regular trade missions to new EU member states



The *Beton De Clercq* company, tracing back its roots to 1898 is steeped in concrete manufacturing. Over the decades, this 4th generation concrete manufacturer, Belgium's pioneer in industrial concrete manufacturing, has evolved into a leading, multi-disciplinary specialist pre-caster, manufacturing a vast range of factory-engineered standard and bespoke precast concrete elements (up to 120 tonnes !) for engineering, environmental, road building and architectural landscaping applications.



Over the last decade, the company has moved increasingly into the environmental part of the market, wastewater treatment in particular. Its unwavering commitment to innovative product development in the area of sustainable and environmentally-sound engineering and water treatment and management practices, have earned the company twin eco-efficiency and innovation performance quality labels, awarded by the Flemish Government.



All of its systems have been successfully tested to meet the relevant building products regulations and bear comprehensive certification (BENOR, CE...).

A member of the Flanders Concrete cluster of concrete-processing companies, of the Belgian Febe trade association of precast concrete manufacturers and 2 of its constituent product associations, Febelco (concrete pipeline systems) and Febestral (pre-cast concrete paving installation contractors), *Beton De Clercq* features as a trusted supplier of high-specification environmental and structural precast elements to a number of major Belgian engineering, road-building and wastewater treatment companies



Residential, industrial and commercial projects (utilities, road construction, civil and hydraulic engineering...)



BETON DE CLERCQ

Steenkaai 111 | 8000 Brugge

T +32 50 31 73 61 | F +32 50 31 73 65

info@declercq-beton.be | www.declercq-beton.be

DE COENE PRODUCTS



High-performance internal doors...

...and doorsets (built-up units, consisting of a door frame and factory pre-hung door leaves), meeting a broad range of enhanced performance requirements:

- **fire-resistance** properties: swing, sliding, revolving, rebated, double or single-leaf fire doors and doorsets with 30, 60 and 120 min. fire resistance, successfully tested in accordance with the latest national and international fire performance standards and grading schemes (Benor-ATG, Rf), by independent third-party accredited test facilities (e.g. BOSEC, the Belgian Organisation for Security Certification);
- **acoustic** properties;
- **burglar and vandal-resistant** properties;
- **ballistic resistant (bullet-proof)** properties (certified by accredited Royal Military Academy laboratories);
- **X-ray and radiation-shielding** properties;
- **vapour and water-barrier** properties;
- any of the above "**combined-performance features**" doors and doorsets... (some lines even come in an "armoured" version)...



Brussels Berlaymont Building

More... veneered decorative panels for the furniture and interior fitting-out industry, along with a proprietary line of **office furniture**



DF 30, DF 60 and DF 120 (fire door range), *DCA* (acoustics range), *Security and Falcon* (burglar-resistant range), *H24U* (burglar/anti-ballistic) *Niagara* and *Sauna* (vapour and water-barrier range)



Belgium, Luxembourg, Germany, France, UK, the Netherlands



Denmark, Portugal, Norway, Finland, Lithuania, Rumania, Slovenia, Hong Kong



Specialist builders' merchants, stocking a range of "special performance doors", fire door installers, architects and specifiers, property developers and managers, approved inspectors, professional joinery trade...



Batibouw (Brussels)



Bruges Concert Hall

DE COENE PRODUCTS



The *De Coene Products* company traces back its earliest origins to 1888 as a renowned arts and crafts workshop. Following the Brussels *Innovation* department store blaze in 1967, the company changed tack and resolutely moved into the professional fire safety business. Nowadays, it leads the Belgian market and ranks among Europe's prime players within the high-performance doors manufacturing industry. On a daily basis, hundreds of high-specification doors and doorsets are turned out from its 23,000 m², state-of-the-art production site, backed up by an in-depth know-how, an innovative product development drive and a comprehensive technical support package to all parties involved in the enhanced-performance doors business.

Customers are provided with the added benefit of sourcing high-performance door solutions from 1 single manufacturer, who - beside a vast standard range - also supplies bespoke door systems for a variety of configurations in the most challenging projects. These are just some of the company's most high-profile references: the Brussels Berlaymont building and European Parliament, Belgocontrol, Radisson SAS Hotel, Bruges Sofitel Hotel, Lisbon Sheraton Hotel, Bruges Concert Hall...

True to its proven reputation as an innovator, *De Coene Products* develops products and systems, in line with - stringent EN standards and regulations. Apart from the tried-and-tested performance level of its overall portfolio, the company also sets great store by the products' aesthetics, as most series are available in a choice of decorative facings and finishes...



Both project, commercial and residential areas of application: hotels, apartments, office buildings, hospitals, care homes, clean rooms, swimming pools, wellness centres, schools, arts centres...



Belgocontrol (Brussels)



Boarebreker residential care home (Ostend)



European Parliament (Brussels)

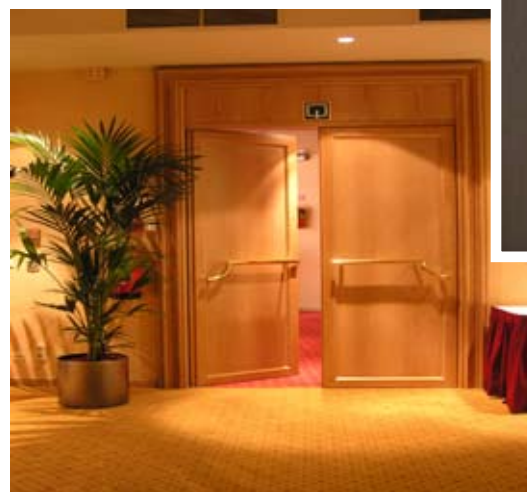

Bruges Sofitel hotel



DE COENE PRODUCTS

Europalaan 135 | 8560 GULLEGEM

T +32 56 43 10 80 | F +32 56 43 10 90

info@decoeneproducts.be | www.decoeneproducts.be

DE NEEF CONCHEM



Structural waterproofing chemicals for above and underground structures

(concrete construction joints, basements, vaults, cellars, potable water basins, tunnels, tanks, dams, sheet piling, underground transport systems, sewers and sewage treatment plants, subterranean storage areas, multi-storey car parks, bridge decks...)

Preventative waterproofing: cementitious waterproofing coatings and liquid/spray-applied elastomeric membranes, coatings, waterstops, sealants, resins, admixtures, "hydro-active" mastics and rubbers (blocking water seepage by swelling when in contact with water), expansible sealing strips (e.g. Bentoject®, involving a combination of a bentonite-filled synthetic rubber outer skin and an inner injection hose, later to be injected with resin dispersions and/or micro-fine cement grouts).

Remedial waterproofing: single and 2-component PUR, polyacrylate and Polyurea-based (injection) resins.

Soil and rock stabilization, consolidation and support: filling voids, cracks, crevasses, curtain and blanket grouting, curtain injections, chemical containment, geogrids...

Repair and protection against deterioration of reinforced concrete or masonry structures: cementitious waterproof mortars, grouts and renders, epoxy resins for crack injection, epoxy adhesives, slurry coating, bridge deck overlay systems, carbon fibre laminates, geosynthetic materials...



Hydro-Active Grouts

Swellseal



Hydro-Active Grouts, Tacss, Elastopack, Gelacryl, Multigel, Sealfoam, Afterswell Rockstab, Aquatek, Omnitek, Multitek, Denepox, DenePur EM, Bentorub, Bentoject, Swellseal (3V, 8V, Mastic), Infiltra-Stop, SIS, Re-Injecto, Carficom Colflex...



Europe, US, Asia



Australia, Greece, Poland, Serbia, Montenegro, FYR Macedonia, Bosnia-Herzegovina, Kuwait, Oman, Qatar, North Africa, Far East



Importers, distributors with a proven experience as building chemicals distributors, structural waterproofing, specification professionals (architects, planning authorities, major general contractors, engineering companies and specialist applicators)



Regular presence at international trade events specializing in tunnelling, underground construction, hydraulic engineering...: Betondagen (Brussels), World of Concrete (US, Mexico), Trenchless Construction events, Rapid Excavation & Tunnelling Conference & Exhibition (RETC)...

DE NEEF CONCHEM



Looking back on 35 years of frontline experience as a manufacturer of specialist preventative and remedial waterproofing construction chemicals, De Neef Conchem, with manufacturing plants in Belgium, Spain and the USA and fully-owned branches in 15 countries across Europe, Asia and the US, has resolutely developed into a top-ranking global player setting the industry benchmark for professional and high-specification waterproofing. Using information from its broad international customer base, the company has been able to put to market a truly impressive range of speciality chemicals and accessories, exported globally to over 50 countries.



This solutions-driven approach has led to a host of innovative product improvements and developments: e.g. the *Swell-seal* slow-swelling sealing strips, available in various dimensions and profiles (flat, square, circular) and in varying degrees of expansibility (from 3 to 8 times its original volume) or the *Colflex HN* ready-to-use sealing membrane for high-dilatation joints.

Comprehensive patent coverage, manufacturing and product certification (ISO 9001-2000, CSTB France, German AbP, NCTRCA...), with a growing number of its flagship products tested against EN 1504 and ETAG 005 EU standards and CE-approved.

Among the many international reference projects in which De Neef Conchem products have been specified to ensure vital waterproof integrity, these are just some of the most prestigious ones: Vieux Canal Saint Martin and the Seine Embankment stabilisation (Paris), Beijing National Grand Theatre, London Discovery Docks, El Obour Power station (Egypt), Jakarta former Presidential Residence, KCRC East rail extension, Che Kung Mi Station, Kowloon train station, Singapore Suntec City, Ponte de Lima motorway tunnel (Portugal), Oslo Underground extension, Toulouse Underground construction, Iséables Protection Civile Centre (Switzerland)...

Well-designed and highly informative multilingual website (some of them market-dedicated by international De Neef associate companies), featuring full literature on core products (resins, membranes and cementitious grouts), downloadable technical datasheets, application instructions, security guidance notes, detailing documents, specification aids, multi-lingual corporate newsletter...

The company also provides the broadest technical assistance -on and off-site- to all parties involved in waterproofing specification procedures through training, regular on-site demos, an on-line technical reference library... It also implements an integrated policy of recycling raw materials and waste, along with its affiliated company, De Neef Chemrec, specialized in solvent and fluid chemicals recycling.

It is also a key supplier of a number of innovatively recycled building materials (building boards, grass slabs and decorative panels) to the Belgian Recyhouse project, aiming to encourage the reuse of secondary building materials.



Project market in civil engineering, industrial, commercial and public works: tunnelling, dam building, sewerage systems, earth moving, mining, underground construction...

DE NEEF CONCHEM

Industriepark 8 | B - 2220 HEIST-OP-DEN-BERG
T +32 15 24 93 60 | F +32 15 24 80 72
www.deneef.eu | conchem@deneef.eu

DE RYCK DECORATIVE STONE PRODUCTS



Decorative reconstructed stone products (brick or natural stone appearance)

The vast array of stone veneer and brick slip cladding for indoor and outdoor use provides a high-quality, lightweight alternative to genuine brickwork or natural stone finishing. The replicated stone range is available in a broad choice of textures, patterns, colour shades (as much as 50) and auxiliary products (adhesive and pointing mortars, sealant finish coatings...)



Murok, Granulit, Interfix, Interock



Worldwide to about 20 countries, European markets mainly



UK, the Middle East, Turkey...



Importers and distributors of building materials, professional builders merchants



Batimat (Paris), Batibouw (Brussels), Bau (Munich);
Cevisama (Valencia), Cersaie (Bologna) (participation by importer)



In-house design, manufacturing and product range development;



Stringent quality control: best-quality raw materials used only (the purest sand varieties, the whitest cements and other natural aggregates (quartz, sea-shell slivers...))

Comprehensive marketing support package: showroom display units, technical support manuals...



B2B: building materials wholesale supplying the professional market (layers, contractors...);
B2C: non-professional end-users (DIY market)

DE RYCK DECORATIVE STONE PRODUCTS

Herentalsebaan 440 | B - 2100 ANTWERPEN

T +32 3 320 82 09 | F +32 3 322 81 33

info@deryckdecorativestone.be |

www.deryckdecorativestone.be





Quartz engineered stone panels

Diresko Stone is a compound stone of high-quality natural stone aggregates (quartz or granite chippings, silica sand), suspended in a resin bonding agent.



Not only do *Diresko Stone* slabs faithfully replicate genuine granite and marble varieties, which makes them a great alternative option to “the real thing”, they also feature a number of outstanding technical properties with regard to their:

- compressive and bending strength (the use of quartz yields it up to 4 times more strength);
- scratch resistance;
- water absorption and frost/thaw resistance;
- resistance to impact, corrosion and chemical attack exceptional colour consistency;
- optimum size tolerance performance.

Due to its excellent durability, it can be used in a broad scope of applications in some of the most exposed environments: kitchen worktops, bathroom vanity units, shower and fireplace surrounds, interior and exterior wall cladding, terraces, stairs, floor and wall tiling,

Diresko Stone slabs are available:

- in a standard 140cm x 300cm size;
- in 12, 20 and 30mm thicknesses;
- in 3 surface finishes (antico, honed or polished to a high gloss);
- in no less than 26 standard colour patterns (bespoke colours can be negotiated for agreed minimum quantities).

Diresko Stone

Australia, Cyprus, Germany, France, Ireland, Israel, the Netherlands, Portugal, UK, Ireland

Far Eastern countries, CEE countries, Northern Europe



DIRESCO



Architects, stonemasons, kitchen and furniture manufacturers, cabinet makers, project developers, contractors



Batibouw (Brussels)



The *Diresco* company boasts a purpose-built factory with cutting-edge manufacturing equipment and a daily production capacity of 2500m² of compound stone slabs, an in-house laboratory and R&D department, well-trained operatives, an expert network of distributors, able to meet the tightest delivery schedules and offering international customers comprehensive technical and commercial support.

Diresco Stone is a food-grade material, manufactured from prime-quality raw materials, using patented state-of-the-art vacuum vibrocompression technology.



Both project market (hotels, public buildings, hospitals), commercial and residential markets



DIRESCO

Industrieweg Noord 1134 | B - 3660 OPGLABBEEK

T +32 89 85 69 44 | F +32 89 85 38 16

info@diresco.be | www.diresco.be



Rotational moulding

The comprehensive product portfolio includes: septic tanks, rainwater storage tanks, small-scale water treatment systems, grease-skimming tanks, rainwater harvesting systems, PE and PVC manholes, deep inspection chambers and a patent-protected services and ductwork connection system.

A broad range of accessories, auxiliary fittings and supplies are available for all systems on offer.

More... chemical-resistant LLDPE barrels, red-and-white New Jersey barriers, karting lane barriers (preferred supplier status with some of Europe's major kart racing circuits)

France, the Netherlands, Rumania

France, the Netherlands, UK

Major importers and wholesalers of building materials, the builders' merchant trade, contractors of residential dwellings

Batibouw (Brussels) as an exhibitor and other building-related trade shows as a regular trade visitor

Set up originally in 1992, *DS Plastics* has developed over the years into one of Belgium's major players on the rotational moulding market, tapping into the vast know-how of its staff, using highest-grade raw materials (LDPE and HDPE) and top-class tooling and moulding equipment and manufacturing a broad range of hollow plastic products that comply with all applicable standards, regulations and performance requirements (CE, EN, BENOR, ATG...).

DS Plastics' product development effort is focused on environmentally sustainable schemes (wastewater treatment and surface water management and recycling solutions). The company has vast expertise in custom rotational moulding commissions and pursues a comprehensive warranty policy.

Project market and private residential market



DS PLASTICS

Moorstraat 25 B | B - 9850 NEVELE

T +32 9 280 78 80 | F +32 9 280 78 89

sales@dsplastics.be | www.dsplastics.be



Flexible high-speed industrial doors

Prime characteristics:

- Door panels made of a heavy-duty PVC-coated curtain;
- High opening speeds (up to 3m/s for some models);
- Crash-forgiving and fully self-repairing, impact-resistant, tear-free;
- Optimum safety for users: no rigid parts or bottom bar allowing the door panel to effortlessly drape around any obstacle in its way;
- Tight sealing, providing a perfect barrier against draught, humidity, noise, dust...;
- Resistant to high winds;
- Broad standard range of small, medium to large size dimensions up to 11 x 5,5m, other measures custom-made.

Dynaco's indoor and outdoor range of high-performance industrial doors are applied in various industries, each with their own specific requirements regarding hygiene, security, environmental and climate control and traffic flow intensity: cargo handling, airfreight distribution and transshipment areas, pharmaceutical and healthcare, retail, automotive and logistics industries, cold storage and refrigeration...

Proprietary *Dynaco* brands:

- outdoor range: *Power, All Weather*;
- indoor range: *D-311, D-313* and *Compact*;
- special purpose: *FM2, Cleanroom* and *Emergency Exit*

Worldwide (Europe, Japan, US, Asia)

Worldwide marketing effort ongoing

Distributors of industrial doors, materials and dock handling equipment, loading bay systems

Batimat Paris), International Garage Door Exposition (Las Vegas), R + T (Stuttgart), Factory Automation (Hannover), Swissbau (Basel), Secura (Brussels)

For *Dynaco*, the door onto the global market swung open back in 1987, when founder and current chairman, Benoit Coenraets, designed a revolutionary flexible high-speed roll-up, roll-down and reseal-type industrial door.

Now, 20 years later, the company ranks among the world's top 3 companies in the industry with over 60,000 doors installed worldwide.



DYNACO EUROPE

The product is manufactured in Belgium, Japan and the US and is sold in over 50 countries. The company was awarded the Belgian Royal Export Award for global trade performance in 2000.

Constant R&D and application-specific innovative product development (e.g. improved fire-resistance, sound insulation, aesthetic finish for high-visibility areas...);

Worldwide patent-protected, *Dynaco* systems fully comply with CE and all applicable EN regulations.

Numerous references and preferred supplier status with worldwide customers of international renown across various industries: Brussels International Airport, Coca-Cola, Centre Leclerc, Daimler Chrysler, Hipercas, Hydro Aluminium, the Madrid Underground, Makro, Onyx...

The company maintains a highly-informative and multilingual website.



Non-domestic, industrial and services markets

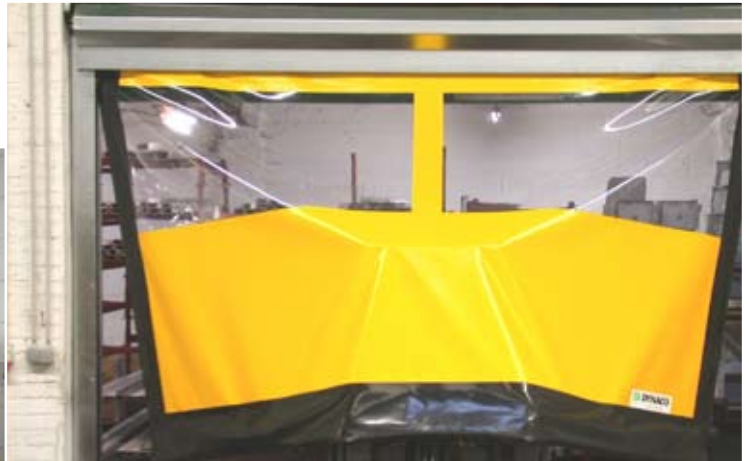

DYNACO EUROPE

Waverstraat 3 | B - 9310 MOORSEL

T +32 53 72 98 98 | F +32 53 72 98 50

info@dynacodoor.com | www.dynacodoor.com



Eternit

Fibre cement (FC) cladding and building boards

1. FC Cladding

Common features to all cladding materials in the extensive *Eternit* portfolio are their durability, fire-safety, dimensional stability, colour-fastness, weather resistance and the fact that they are environmentally sound, lightweight, easy to handle, work and install and low on maintenance.

They are made of high-grade raw materials, using the most advanced manufacturing equipment in a comprehensively quality-controlled factory environment and have a 10-year durability guarantee.

All cladding materials have their own distinctive aesthetic appearance and are designed to meet any project-specific technical requirements occurring in residential, commercial, institutional or utility building schemes.

Indoor and outdoor applications range from smaller building parts (soffit, fascia...) to large-scale cladding projects (high-rise buildings) or in demanding environments (tunnels, operating theatres, food-processing plants, sanitary facilities...)

The range comes :

- in many formats (strips, panels, façade slates) including cut-to-size to customer specification;
- with a variety of fixing methods, visible or invisible, with glue, rivets, screws or various decorative fixings elements on wooden battens or a metal substructure;
- in a wide choice of standard colours and surface finishes (smooth, fine granular, mineral enamel coated or wood grain textured), transparent and through-coloured...

Some of the brands taking centre stage in the Eternit cladding range are *Multiboard*®, *Sidings*®, *Glasal*® and *Eter-Color*®.

Multiboard®: a versatile cladding panel with a discreet granular finish or *Multiboard Soffits* for finishing small building elements.

Sidings®: weatherboarding strips, with a cedar wood texture or smooth finishing. *Glasal*® NT, a double-compressed, steam cured, rigid fibre cement sheet that is scratch resistant with a smooth coated surface.

Eter-color®, a through-coloured cladding panel.

2. FC Building boards

Range of high-performance FC building boards, suited for a variety of structural covering applications, both indoor and



ETERNIT

outdoor, providing special properties with regard to fire, damp, mould or impact resistance, e.g. as underroof wind-screen, rainscreen panel or backerboard for rendering, surface coatings or other finishes (tiles, brick slips...)

More... other construction materials are supplied by one of 80 *Etex*-affiliated companies: FC roofing slates, FC corrugated sheets and metal profiled sheeting, clay rooftiles, concrete tiles, natural roofing slates, ceramic floor and wall tiles, vinyl floor coverings, fire-protection and high-temperature insulation materials...



Eternit (corporate brand) *Sidings*, *Multiboard*, *Glasal NT*, *Eter-Color*... (cladding brands);
Eflex, *Eter-Board MD/HD*, *Eter-Backer MD*, *Eterspan*, *Menuiserite*, *Bluclad*, *Masterclima*... (building board brands).



Europe



Ongoing market development effort across Europe



Cladding range: architects, consulting engineers and/or distributors, agents, importers;
Building board range: builders' merchants and DIY chains.



Sales presence at most major European building and construction fairs (participation by agent or distributor)



The *Eternit* company is a part of the Belgian *Etex Group*, the world's largest manufacturer of fibre cement building products and a leading supplier of high-quality building materials and systems. With 100 years of industry knowledge and manufacturing experience, the company now operates globally, with 80 subsidiaries across 39 countries.

Over the decades, *Eternit* has built an unparalleled reputation for product quality and service excellence.

The company is ISO 9001-2000 certified and also holds ISO 14001 certification for its environment management system, testimony to its commitment to sustainable manufacturing.

All of its products are rigorously tested and meet the most stringent international standards as regards performance and durability. The company's understanding of the needs of designers and installers alike, backed up by comprehensive technical support, confirm its role as a preferred supplier of cladding and roofing solutions to the international construction industry.



Implementing a dynamic product innovation policy, *Eternit* continues to develop high-performance FC roofing and cladding systems, promoting them as architectural design elements enhancing the built environment.



Residential, institutional, commercial and public utilities projects

ETERNIT

Kuiermansstraat | B - 1880 KAPELLE-OP-DEN-BOS
T +32 15 71 74 25 | F +32 15 71 74 49
export@eternit.be | www.eternit.be



Precast industrial concrete floor slabs



Eurodal



The Netherlands, France and Germany



The Netherlands, France and Germany



Distributors, agents, architects, consulting engineers and specifiers



Industrie- & Projectbouw (Antwerp), Matexpo (Courtrai-Belgium), Demomat (Mons-Belgium)



The family-owned *Eurodal* company started manufacturing industrial concrete floor slabs back in 1982. Through continuous research and innovative product development, it soon developed into a prime provider of industrial flooring.

Its ground-supported 2m x 2m standard-sized floor slabs are cast at its fully-automated, state-of-the-art manufacturing plant.

The movable and re-usable *Eurodal* slabs are ideally suited for temporary industrial flooring needs. They have a broad scope of application in industrial and commercial environments (parking areas, storage and warehousing, loading bays, access pathways, civic amenity sites...), providing a high-quality, cost-effective alternative to competing flooring materials like on-site poured concrete, block paving or asphalt.

On-site labour time is reduced - our specialist installation team typically tackles as much as 1000 m² a day - ensuring minimum production downtime during installation and ready availability for surface traffic. The company also offers comprehensive rental and leasing options.

Continuous product improvement and innovation: broad choice of colours and surface patterns/textures, allowing an aesthetic use in domestic hard landscaping, liquid-proof or permeable variants available (e.g. for sustainable drainage schemes).

Trusted supplier across various industrial branches to customers of international renown. Member of the Flanders Concrete cluster of concrete-processing companies (www.flandersconcrete.com).



Mainly industrial project markets, but gaining ground in urban and residential development projects.

Eurodal



Industrial Flooring Solutions



EURODAL

Industrieweg 14 | B - 2280 GROBBENDONK

T +32 14 50 05 91 | F +32 14 51 72 10

eurodal@eurodal.be | www.eurodal.be

EUROPE TWIN TILE



Lightweight metal roofing and cladding tilesheets and slates

A revolutionary, lightweight alternative to traditional clay or concrete roof tiles.

The patented *Twin Tile* system is an all-in-one "tile-effect" roofing panel (8 tiles to one panel), comprising a double 0,3 mm deck core of zinc aluminium galvanised steel, bonded by a polymer foil barrier and with a high-quality proprietary powder coating finish.

The system is suited for all roof types with pitches from 5° to vertical and comes in 6 standard colours/patterns, with other RAL colour shades available on demand

Apart from the original *Twin Tile* line itself, the range includes a number of follow-on materials:

- *Ecotile* (single sheet tile, available in either 0,3 or 0,5 mm thicknesses);
- *Thermo Twin Tile*: PUR insulated roofing tile-sheet (R value: 2,544);
- *Metal Slate*: available in 3 different dimensions (20/20, 30/30 and 37.5/37.5 cm), suited for roof pitches from 15° to vertical.

While offering the appearance of traditional clay or concrete roof tiles, the *TwinTile* system features a number of advantages over traditional roofing (and cladding) materials: lightweight (a fraction of the weight of traditional roof tiles) but sturdy, unbreakable and vandal-resistant, reduction in roof structure (e.g. no tiling battens required with *Thermo Twin Tile*), ease of installation, hidden fastening, reduced labour costs, low maintenance, proven noise reduction properties, high-quality scratch and UV resistant powder coating, meeting ISO 9001 requirements...

Twin Tile, Eco Tile, Thermo Twin Tile, Metal Slate

The Netherlands, Germany, UK, Austria, France, Slovenia, Russia, Iran, Nigeria, Cameroon

Any international trade lead will be followed up, particularly those from Russia, Slovenia and Africa (Morocco, Sudan, Libia, Senegal...)

Agents, importers, distributors of building/roofing materials, builders' merchants, DIY chains, major building contractors, architects, consultant engineers, construction project managers



EUROPE TWIN TILE



Interbuild (Birmingham), Big 5 (Dubai), Batimat (Paris)



Mr. Dominique Smeets, current CEO of the *Europe Twin Tile* company, once a Thatcher himself, introduced his revolutionary *Twin Tile* roofing concept in 1998, to instant international acclaim.

The company now features among the major players in the lightweight metal roofing business for both new-build, refurbishment and re-roofing projects.

The patented system is backed up by the development of innovative follow-on products (e.g. the thoroughly-tested *Thermo Twin Tile* with improved insulating properties), new colour shades and patterns...

Comprehensive choice of accessories, tools and ancillary fittings (ridge caps, fascia boards eaves trim boards, ventilation units...)

Stringent quality monitoring and third-party certification: ISO 9001 certified proprietary high-grade powder coating, exclusively developed by a major international coatings supplier, used on the entire *Twin Tile* range, providing improved UV resistance and long-term colour stability.



All products are ATG approved, with BBA certification assessment ongoing.

In-house team of trained professionals providing expert advice and hands-on technical support on and off-site;

Comprehensive guarantee coverage: 30 years' warranty against weather-proof failure.

Residential market mainly, with light commercial to industrial applications (to a lesser extent)



EUROPE TWIN TILE

Nijverheidslaan 1528 | B - 3660 OPGLABBEEK

T +32 89 81 25 84 | F +32 89 81 25 82

info@twintile.be | www.twintile.be



FRP composite materials for internal and external strengthening of concrete and other building products (rock, soil, masonry and wood)

The FRP range includes:

1. glass-fibre (GFRP) and carbon (CRFP) rebars for internal, non ferrous reinforcement (specialist application: soft eye openings for TBM launching and exit shafts...);
2. externally bonded CFRP and GFRP sheets and laminates for external concrete reinforcement of beams, slabs and columns;
3. steel and synthetic fibres for internal concrete reinforcement (instead of conventional rebar or steel mesh reinforcements for use in precast and on-site casting...);
4. specialist GFRP anchors, rock bolts, dowels and soil nails for strenghtening tunnels, quayside walls and dockyards, unreinforced masonry buildings (consolidation, rehabilitation, retrofitting).



Due to their non-ferrous nature, FRP reinforcements offer a unique alternative to steel-based reinforcements: crack and shrinkage-resistant, excellent impact and fatigue resistance, no corrosion (even in marine environments, desalination plants, chemical industry), lightweight but high-strength, magnetic transparency (suited for MRI wards, airport control rooms, transformers, electronic testing facilities....)



Fortfiber, Aslan, Fibril, Fortresin



Europe and the Middle East



Ongoing worldwide marketing effort pursued



Designers, architects, engineers, specifiers, specialist concrete contractors...



The Big 5 Show (Dubai)



As a trusted partner to some of the world's most prominent manufacturers of composite materials for internal and external concrete reinforcement, *Fortius* has made a name for itself as a preferred supplier of the best available alternative reinforcement techniques to a number of high-profile engineering projects, both new build and rehabilitation. It provides comprehensive technical support, design and specification assistance to designers, engineers, consultants and owners.



Fortius is a member of the Flanders Concrete cluster of concrete-processing companies (www.flandersconcrete.com) and key supplier of all fibre reinforcement solutions to the Belgian *Concrete House* project, pioneered and promoted by a team of Belgian architects.



Project market mainly

FORTIUS

Grasbos 50 | B - 3294 DIEST
 T +32 13 32 68 73 | F +32 13 32 68 74
info@fortius.be | www.fortius.be

HULLEBUSCH



Manufacturer and distributor of “antiqued” and modernist natural stone products

Sourced from trusted and reliable suppliers across the globe, the vast *Hullebusch* range of natural stone varieties includes limestone, marble, Belgian bluestone, sandstone...



Beaumaniere *rustica* finished

Apart from a huge standard range of slabs, floor tiles, cladding panels and strips... the company also supplies bespoke building and fitting-out elements like kitchen worktops, bathroom vanity units, shower and fireplace surrounds, pool edge coping stones...

Hullebusch natural stone products come in a varied range of surface finishes, suited to the requirements of any architectural project in settings ranging from the antique and traditional to the sleek minimalist.

Surface finishes include: sawn, honed, veccario, cottage, roulato, style romano, Soignies style...



HULLEBUSCH master in stone



Europe, US, Canada, Russia, Kuwait, Japan, Australia, New Zealand



Worldwide marketing effort ongoing



Natural stone importers, distributors and resellers, project developers



Exhibiting at and/or frequent trade visits to both specialist events: Stone+Tec (Nuremberg), Natural Stone Show (London), Marmomacc (Verona), Natuursteen (Apeldoorn), Coverings (Orlando), Surfaces (Las Vegas)...
...and general construction fairs: Batibouw (Brussels), Batimat (Paris), Budma (Poznan)...



Gris Foussana - honed finish

HULLEBUSCH



3 decades of stone-processing tradition and know-how within the family-owned, 2nd-generation *Hullebusch* company has developed the company into what it now is: one of the most highly respected European suppliers of “antiqued” natural stone with overseas sales continually on the up.

The company operates two production units (one for slabs and antiqued tiles and one for bespoke natural stone designs), equipped with state-of-the-art processing machinery. It has extensive storage facilities, holding a wide range of stock, a broad sample of which is on view at its lavishly stocked showroom.

In a permanent bid to develop and innovate its product portfolio, *Hullebusch* is constantly scouring the globe for exclusive natural stone varieties, which it expertly converts into gloriously finished detailing elements, suited to any architectural scheme.

A good working relationship with contemporary architects and designers and early-stage project involvement further enables the company to regularly launch new product varieties (e.g. the *Aegean Pebbles*, *Natural Cubics* or the stylishly contemporary *Matchstick* or *Mediterranean* collections) or to introduce new hues (gris *Foussana*, *Casablanca grey*, *Cream de Sintra*, *Topaz Dune*...) or surface finishes (*Veccario*, *roulato*, style *Romano*, *Soignies style*...)



Dorsaf *Soignies style*-finished



Residential and commercial projects



Belgian bluestone - style *Romano* finish



Kitchen worktop topaz dune honed

HB
HULLEBUSCH
master in stone

HULLEBUSCH

Brugsebaan 4a | 8850 ARDOOIE

T +32 51 46 78 67 | F +32 51 46 78 71

info@hullebusch.com | www.hullebusch.com



Bitumen roofing shingles

The comprehensive product portfolio consists of the following shingle types: from the time-tested and widely applied basic standard range, the “upgraded” range of shingles with a higher bitumen content and thicker fibreglass felt, the laminated double-layer ones, the self-adhesive shield shingles, through to the high-performance premium range of improved, APP modified bitumen shingles.

The shingle range is available in 4 shapes (square butt, hexagonal, beaver’s tail and diamond-shaped), in about 60 attractive colour shades and a number of accessories (sealants, corrosion-resistant nails, proprietary underlay materials, matching valley sheets, roof and ridge vents, premanufactured hip and ridge capping shingles).

Designed to suit the demands of any roofing scheme, to meet the needs of professional installers and DIY enthusiasts alike and to provide a long-lasting weatherproof aesthetic roof finish, bitumen roof shingles are a fitting alternative to traditional roofing, boasting several unmistakable advantages: lightweight and hard-wearing, offering design flexibility and highly compatible with a variety of pitched roof situations (from 20° to vertical), high resistance to colour fading, great sound insulation properties and a cost-effective pricing structure.

Proprietary IKO brands (*Superglass, Armourglass, Victorian, Diamant, Cambridge, ArmourShield, BiberShield, DiamantShield and Monarch*)

Europe, Asia, Africa, Australasia

CEE countries, Turkey

Importers and distributors of roofing/building materials, professional timber building manufacturers, major builders’ merchants, DIY operators

Roof Expo (Ghent, Belgium), Dach&Wand (Köln), Batimat (Paris)

Belgian-based *IKO Sales International* was set up in 1972 as the European HQ of the Canadian IKO company, a global leading manufacturer of bituminous roofing and waterproofing products and prime worldwide exporter of bitumen shingles.



IKO SALES INTERNATIONAL

The company is Europe's sole manufacturer of bitumen shingles, producing an impressive range of top-quality bitumen shingles for the European and Asian markets.

Drawing on over 50 years of shingle manufacturing know-how of its parent company, on its own dynamic R&D, product innovation and development effort and state-of-the-art technology, the company now sets the trend in shingle roofing design with regular additions to the product range (development of designer shingles, colour and shape variation).

Stringent quality monitoring: high-grade bitumen on a fibre-glass tyre basis, ISO 9001/2000 certified manufacturing to the EN-544 standard (of which the company helped lay the foundations), high-quality, ceramically coated granulate finishing, multiple independent third-party certification and product approval, unparalleled warranty coverage, compliance with all relevant international safety requirements

Outstanding service level evidenced by worldwide references in a broad range of roofing projects in domestic, utility and commercial environments

Well-designed and informative website, containing technical details and fixing instructions, along with e.g. the *Roofviewer* interactive shingle selector tool and the *Roof Estimator* tool for calculating material quantities



Residential and project markets

IKO SALES INTERNATIONAL

I.Z. Ravenshout 3815 | B - 3945 HAM
T +32 11 34 01 20 | F + 32 11 34 01 30
iko@iko.be | www.iko.be



Line drainage and channelling systems for surface water

Other drainage-related systems, components and accessories (access/manhole covers and gratings in ductile cast iron, cast aluminium, galvanised or stainless steel, gullies, decorative floor and shower drains, MDPE, HDPE and PVC deep inspection chambers, systems for small-scale wastewater treatment and stormwater management (water storage tanks, grease traps, septic tanks)



Stora-Drain (polymer concrete range) and *Stora-Fonte* (ductile iron range)



The Netherlands, Luxembourg, France, UK, Ireland, Portugal, Italy, Greece, Cyprus, Czech Republic, Poland, Ukraine, Russia



Ongoing marketing effort in the Scandinavian countries, the CEE countries and North Africa



Distributors, agents, DIY chain store operators and builders' merchants wholesale



Pollutec (Lyon) and further participation in a number of prime European construction trade fairs, either as a trade visitor or an exhibitor



Since 1979, *Imcoma* has manufactured and put to market a broad standard range of high-intercept drainage systems. With 60% of production destined for export, the company is the leading provider of drainage solutions on the European market.

The entire drainage range is available in pre-sloped or constant depth versions, with various grating options, with load resistance ratings from A15 to F900 or as a combined kerbing and drainage system...

Applications therefore range from light domestic, medium urban commercial or industrial to the most heavy-duty drainage environments (garden, poolside, patio, driveways, pedestrian areas, parking lots, service areas, motorways, airports, docklands, port quaysides, transshipment areas.... The entire *Stora* portfolio is fully certified and complies with the most stringent quality and performance requirements (ATG, KOMO, EN regulations).

Strong R&D, design and (custom) engineering performance: line drainage catchment and retention calculation software, turnkey drainage schemes, research into new materials, intensive customer product training provided



Both the domestic residential consumer market and the public as well as the private projects market



IMCOMA

Zwaarveld 32 | B - 9220 HAMME
 T +32 52 499 899 | F +32 52 470 776
 info@imcoma.com | www.imcoma.com

IMPERBEL - DERBIGUM



Waterproofing products for flat roofs and civil engineering structures

Broad range of high-performance, glass fibre and polyester-reinforced polymer modified bitumen waterproofing membranes, providing long-term durability (documented by independent research institutes), great dimensional stability, excellent puncture and tear resistance, fire safety (external fire exposure and propagation), UV stability...

Also included in the range are base sheets and vapour control barriers, liquid application products for use with Derbigum membranes (cleaners, substrate preparation primers, cold bonding adhesives, mastics, sealants, protective coatings...), accessories (cant strips and flashings, roof edge profiles, rainwater outlets, decorative seam profile strips) and application tools and equipment (e.g. the innovative Spraygun cold adhesive application equipment or the Mac Max engine for automated fast-track waterproofing of large surfaces, e.g. structural bridge deck waterproofing).

Derbigum membranes (made by the Imperbel company) are used in multi-layer built-up, as well as in single-layer roofing systems - owing to their double reinforcement and outstanding performance characteristics - and allow various methods of application like torching or heat-welding, cold adhesive (spray-) application, mechanical fixation or by no-flame application on buildings with an increased fire and/or explosion risk.

Derbigum's technological leadership and hefty investment in research and development regularly results in such groundbreaking product launches as the innovative Derbigum Brite membrane, which, with its 76% solar reflecting colour-fast white acrylic surface, provides a roof with enhanced visual appeal, improved thermal performance and substantial energy savings. Another Derbigum innovation with ecology in mind is the Derbisedum prevegetated complete green roof solution.



Yamaha Motor Distribution (Schiphol-NL)



Derbigum SP-FR, Derbicolor, Derbigum Arte, Derbigum Brite, Derbisedum, Derbigum AR, Derbibond S, Derbiseal, Derbisilver, Derbimastic S, Derbiprimer S, Derbiprimer GC...



Worldwide



Austria, Australia, Bosnia-Herzegovina, China, Croatia, Cuba, India, Japan, Russia, Serbia, Slovenia, Ukraine, Vietnam

IMPERBEL - DERBIGUM

Lomé covered market (Togo)



Architects, specifiers, general contractors, roofing contractors, roofing materials importers, specialized distributors in building materials

Batibouw (Brussels), Batimat (Paris), Swissbau (Basel), Construmat (Barcelona), Renovatie- en Onderhoud (Den Bosch), Budma (Poznan), Construct Expo (Bucharest)



Kuala Lumpur Petronas Towers (Malaysia)



From humble beginnings in 1932 as a family-owned manufacturer of bituminous mastics, Imperbel has over the decades won increasing worldwide recognition as a leading manufacturer of premium waterproofing membranes. With a marketing presence across Europe, the US, Africa and Asia, the company's 3 manufacturing sites - two in Belgium, 1 in the US - turn out some 17 million m² of *Derbigum*-branded membranes and 9 million kg of liquid waterproofing products.

At present, over half a billion m² of building surfaces the world over have been expertly covered with *Derbigum* membranes.

Derbigum-Imperbel boasts pioneering experience in the field of sustainability: not only are its membranes fully recyclable, with no toxic chemicals added and water-based or low-solvent glues for cold bonding applications, but the company has successfully operated many years of zero waste and energy-efficient manufacturing (e.g. through the in-house developed integrated recycling system and its "16% CO₂ emission reduction by 2012" scheme). Part of the range is particularly suited for energy-efficient and environmentally-sound applications (insulation and solar relectiveness, improved thermal performance, rainwater harvesting, green roof build-up, durable roofing solutions, with a documented

20 to 30-year longevity, comprehensively tested by independent third party research institutes across Europe.

The company has an ISO 9001 quality assurance management system in place and was also awarded ISO 14001 and EMAS certification for its environmental management system. Other accreditations and approvals include: CE mark, ATG (B) FM (US), US Energy Star (US), BBA (UK), UL classification, external fire exposure ratings (B Roof t1/t2/t3)...

The company's multiple prize winning membranes (UK Flat Roofing Association product excellence award, 2006 Batibouw Innovation Award nomination...), have been specified in scores of prestigious waterproofing projects around the world: the US White House, Daewoo Tower (Warsaw), the Yamaha EU Distribution Centre (Schiphol), Usinor Dunkirk, Norske Skog, SAS Stockholm head office, the Lomé covered market, Petronas Tower (Malaysia), the Swiss Lehnen Viaduct...

Its dedicated, multi-lingual website features a broad array of marketing tools, guidance notes, technical datasheets, a reference library... on behalf of architects, specifiers, contractors and home-owners. Its global competence centre provides approved roofing contractors and mechanics from all over the world with specialist technical training on the latest product innovations and expert application techniques.

Warsaw Daewoo Tower



New-build, reroofing of roof refurbishment applications in residential, commercial, industrial building and civil engineering waterproofing projects

IMPERBEL - DERBIGUM

Bergensesteenweg 32 | B - 1651 LOT

T +32 2 334 87 00 | F +32 2 378 14 69

infoint@derbigum.com | www.derbigum.com

IMPERPLEX

imperplex

Protective anti-soiling and anti-graffiti coatings...

... with repellent properties against water, moisture, grease and other oil-based pollutants for use on concrete, masonry, natural stone floors, walls and other porous building surfaces



Imperplex (Colourless, Wax, N.E., Pro, Inject, Floor & Stone, Pro-Stone & Floor



Exports to about 20 (mainly European) markets (The Netherlands, France, UK, Ireland...)



Ongoing marketing effort throughout Europe



Distributors, importers, wholesalers, builders' merchants



Regular trade visits to international trade fairs focused on construction and finishing



Over 30 years' experience in developing and marketing colourless protective coatings (both sacrificial and permanent) for the building industry; Boasting product endorsements from leading Belgian blue limestone quarries/processors *Carrières du Hainaut* and *Pierre Bleue Belge*, the *Imperplex* company offers a broad array of products, thoroughly lab-tested, site-trialled and reported on by various building research institutes, certifying bodies and cultural property preservation centres: BBRI (BE), CEBTP (FR), ICCROM (IT);

Preferred supplier of specialty coatings to numerous high-profile building projects, both national and international

- Teatro Nacional de Catalunya : white marble coated with Pro-Stone & Floor



Residential (consumers, end-users) and specialist contractors' markets

IMPERPLEX

Mechelsestraat 121 B-1 | B -3000 LEUVEN
T +32 475 73 12 15 | F +32 16 23 50 13
info@imperplex.com | www.imperplex.com



INTER-MINERALS



Minerals and crushed natural stone aggregates

Vast array of hundreds of mineral and crushed natural stone varieties, available in an astonishing range of colours, degrees of hardness (according to the Mohs hardness scale), particle sizes (ranging from 0-1mm up to 16 mm diametres, depending on the variety) and pack formats (bulk-delivered or packed in big bags, full or part truck or shiploads...)

More... high-quality glass aggregates in various colours, shape and finish options for use in decorative precast concrete products

Inter-Minerals aggregates are primarily used by the (precast) concrete and asphalt industries, incorporating them in their own finished products: fair-faced precast concrete elements for cladding or flooring, street furniture, block or flag paving, liquid applied flooring, terrazzo or stone carpet resin flooring, reconstituted stone products, decorative plaster and render finishes...



France, Germany, the Netherlands, Poland, Rumania, Russia, UK



UAE, China, Vietnam



Companies operating in the (precast) concrete and asphalt business
For large-scale projects: early-stage liaison with architects, designers and other parties involved in the specification process



As an exhibitor: Big 5 Dubai, CPI (Bonn, Berlin), Betontage (Ulm) Infratech (Rotterdam), worldwide ICCX events;
As a trade visitor: Internationale Bouwbeurs (Utrecht), Bauma and Bau (Munich), Batimat (Paris), Stone +Tec (Nuremberg).



Drawing on 30 years of experience, the *Inter-Minerals* company now ranks prominently as a major supplier of customized speciality aggregates to numerous leading European players in the precast concrete business, helping them to add value and improved aesthetic appeal to their own product range.

Excellent logistics: apart from a German subsidiary, the company operates a trimodal transshipment site in the port of Brussels with quayside crange, mechanical handling equipment, additional processing equipment (for crushing, sieving, washing, drying and packing), covered warehousing and open-air storage facilities, with large stocks of high-quality, CE certified aggregates with full technical specifications sheets.

Permanent quality and supply-chain monitoring: all graded aggregates are sourced from a global network of reliable international quarry operators, governed by long-term supply arrangements. Sample dispatches are swift and deliveries invariably accurate.



Industrial B2B market



INTER-MINERALS

Beenhouwerstraat 1 | B-2830 WILLEBROEK

T +32 3 886 53 90 | F +32 3 886 07 99

info@interminerals.com | www.interminerals.com



Single-ply EPDM membranes...

... for any structure where waterproofing is key: flat roofs, guttering, terraces and balconies, basements, ponds, water buffering reservoirs, sealed tanking, compost storage areas, facade weathersealing and cladding, structural damp and waterproofing, cavity drainage...

Apart from EPDM, PVC and TPO-based membranes (both standard-sized and in bespoke, project-specific dimensions) and a broad choice of accessories, detailing units, ancillary items and application tools for all material types on offer, the I.R.S product range also includes specialist membranes for roof designs with enhanced properties: green roofs, water harvesting roofs, energy roofs with incorporated photovoltaic systems...



Carlisle, Tridex, Mastersystems, Tiplon, Evalastic, Flexsom-Solvay, Securitan, Hertalan, Dow, Index, Orcatec, Pondliner



Italy, France, Austria, Finland, Germany, Norway, Czech Republic, Sweden, Switzerland, Hungary, the Netherlands, Poland, Denmark, Luxembourg, UK



Europe



Importers and distributors of roofing materials, major (industrial) roofing contractors, hydraulic engineering companies, garden centres, builders' merchants



Batibouw (Brussels), Agriflanders and Green Expo (Ghent), Industrie- en Projectbouw (Antwerp), Architect@Work (Courtrai), Futurallia (France)

I.R.S
waterdicht.be



I.R.S WATERDICHT



Since its set-up in 1995, I.R.S – short for International Rubber Systems – has been instrumental in introducing EPDM as a high-grade roofing material onto various European markets.

Partnered with major global suppliers of single-ply EPDM membranes like Carlisle SynTec, Solvay-Alkor Draka, Dow, Hertel, Alwitra...), the company now markets 12 top-ranking EPDM brands across Europe.

Drawing on its supplier companies' frontline manufacturing experience and its own distribution know-how, the company, currently leading the Benelux market with annual sales totalling over 1 million m², also prides itself on a long reference list of successfully finished waterproofing projects across the European mainland.

IRS closely involves in its suppliers' product development and marketing policies and consistently focuses on stringent quality controls, product improvements and innovations (e.g. the labour-saving PRE-TAPE range of tape-bonding EPDM membranes with factory-prefit splicing tape for sealing at joints).

The company's product range is covered by no less than 7 Belgian ATG accreditations, besides a range of other internationally recognized approvals (KOMO, BBA, DIN...) with products often exceeding requirements set by various STM standards referring to EPDM single-ply membranes. Its comprehensive guarantee scheme offers above standard warranty coverage.

The company provides all parties involved in waterproofing with comprehensive customer services: a complete, interactive and well-designed website, full technical support, project calculation and design assistance, product detailing tools, a dedicated training facility with on-site training sessions and follow-on courses on single-ply EPDM application procedures...



Roofing and (structural) damp and waterproofing applications: industrial, commercial, residential, civil and hydraulic engineering, public access buildings, monuments...



EPDM membrane factory-fitted with pre-tape splice

IRS WATERDICHT

Europalaan 73 | B - 9800 DEINZE
T +32 9 321 99 21 | F +32 9 371 97 61
info@irs.eu | www.epdm.eu



Structural insulating sandwich panels and doors

Applications for the *Isocab* portfolio range across various industries with rigorous demands on temperature control (maintaining ambient, chill and freezer conditions), hygiene, humidity, dust control...: chilled and frozen food industry, food/meat-processing, catering and hospitality, industrial (and residential) building and construction...



Specialist applications include large freezer warehouses (up to 40 m eaves height) and indoor ski slopes, with successfully finished projects in Belgium (Comines and Peer), Spain (*Xanadu* - Madrid), France (Amneville) and Dubai (*Ski Dubai*, the world's largest indoor snow park and ski resort).

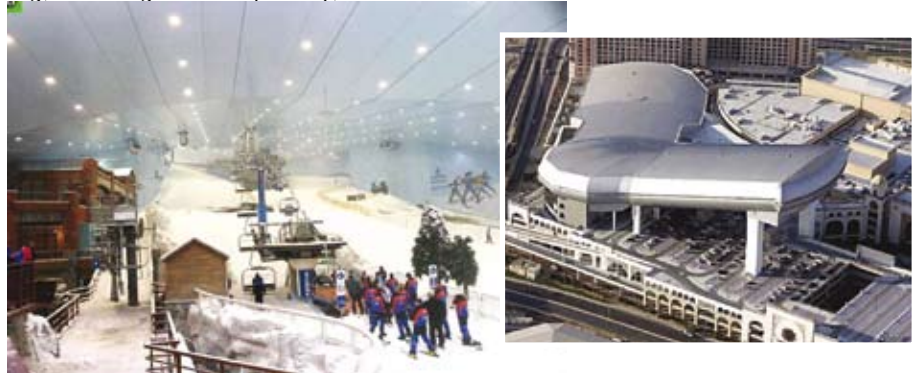

Featuring in the *Isocab* product range are:



- the *ISO* and *Minibox* ranges of structural sandwich panels for modular build-up of cold storage rooms, chambers and walk-in coolers. Constituent panels consist of an insulating PUR or PIR core material between two facings, double tongue-and-groove interlocking, foamed-in cam locks, allowing easy assembly, dismantling, enlarging, even relocating cold storage units in a broad range of design options;



- fully-engineered, insulated doors for ambient, chill and freezer applications: hinged doors, sliding doors, revolving doors, double-action swing doors... Easily incorporated in all modular storage solutions by *Isocab*;



- structural insulated wall and roof panels for industrial purposes (available in 2 to 19 m lengths and a 40 to 200 mm thickness range, catering for any thermal insulation requirement);



- single-ply metal profiled sheets for vertical wall cladding and roof decking applications (cold and warm roof build-ups, soffits...);
- a broad range of aluminium and steel accessories, ancillary equipment and fittings for a superior hygiene performance level



More... modular clean rooms (through its subsidiary company *Retan*) and low-cost prefabricated housing construction system for fast-track building schemes





Continuous R&D has consistently led the company to present innovative additions to its product range, like the *FC* panel series with hidden fixing, panels with “enhanced properties”, e.g. the *Isoguard* panel for applications in aggressive environments or panels with improved fire behaviour (up to 3 hours’ fire resistance for the *Decaroc* mineral wool core panel or the new PIR core panel, tested against European EN13501 standards and offering 37 to 68 min fire resistance).

® *Isocab and Retan Products*

🌐 Worldwide

👤 Turkey, Lebanon, UAE, Russia, Vietnam, Iran...

📍 Cold storage industry, food processing, any industry with a cold storage requirement, building contractors, architects, specifiers

🏭 Industrial project market



Regular exhibitor at some of the world’s largest building and “refrigeration-related” trade fairs: Batimat (Paris), Big 5 (Dubai), IKK (Hannover and Nuremberg), Seafood Processing Europe (Brussels), Meat & Fresh (Courtrai), Industrie- en Projectbouw (Antwerp), Int’le Bouwbeurs (Utrecht), 3C (Birmingham), Medtec (Stuttgart), CFIA (Rennes), Contaminexpo (Paris)...



Set up back in 1973, *Isocab* originally started manufacturing small to medium-sized cold storage rooms. Over the years, it gradually broadened the scope of its activities and diversified into the industrial arm of the refrigeration business.

The company’s frontline experience in the structural insulated panel business, combined with a continuous investment effort, a drive for product innovation, an outstanding service level, a strong commitment to sustainable manufacturing, early involvement in all project stages (from design, engineering, manufacturing through to the actual installation on site) has eventually turned *Isocab*, now part of the *Thyssen Krupp* group of companies, into an unrivalled player in the European insulation industry with worldwide sales.



All *Isocab* products, systems and services are designed, built and supplied to comply with ISO 9001 performance criteria and with the latest national and international building standards.

ISOCAB

Treurnietstraat 10 | B - 8531 BAVIKHOVE
 T +32 56 73 43 11 | F +32 56 73 43 22
 isocab@isocab.be | www.isocab.be

ISOLAVA



Plasterboards and plaster blocks for non-loadbearing internal applications (partition and infill walling systems, linings and ceilings...)

Apart from a comprehensive standard offering of plasterboards and plaster blocks (the latter with interlocking tongue-and-groove edge detail for ease of construction), the Isolava range also includes specialist wallboards with specific performance characteristics in the areas of thermal and acoustic performance, moisture resistance and fire protection: the Belgisol insulating laminate, consisting of a foam or mineral fibre-based insulation material bonded to a wallboard panel or the cementitious tile backing Aquapanel board, providing high levels of moisture resistance in wet indoor areas. Complementing the range are the easy-to-assemble metal frame construction system and a full line of accessories for drywall and suspended ceiling applications.

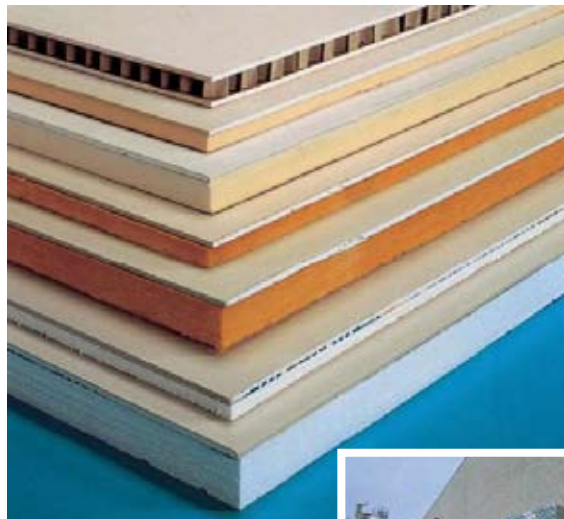

Major proprietary brands: Isomur, Hydromur (plaster blocks), Belgips, Knauf (plasterboards), Belgisol (insulated thermal laminates), Aquapanel (cement boards)



70% of production exported to France (incl. DOM-TOM), Germany, Iceland, Ireland, the Netherlands



Ireland, Iceland



Builders' merchants, DIY chains, architects and product specifiers, contractors, project developers



Afbouwexpo (Den Bosch), Nordbat (Lille), Artibat (Nantes), Batibouw (Brussels), along with a number of regional construction-related trade fairs in Belgium

ISOLAVA

The Isolava company, set up back in 1967 and now part of Knauf Gips KG, one of Europe's leading building materials manufacturers, operates 2 highly-specialized plants in Belgium, manufacturing plasterboards and plaster blocks.

Some of the company's prime assets are:

- innovative product development in close partnership with specialist drywalling contractors;
- stringent quality monitoring, comprehensive product and system certification (KOMO, NF, DIN, ISO 9002, ATG), rigorous testing, both in-house and by independent third-party accreditation bodies (KIWA, CSTB, Otto Graf Institut, Eurosym);
- Logistic excellence for timely deliveries both to warehouse and on site, large stocks maintained of plaster blocks, boards and accessories allowing single bulk consignments to customers;
- Ongoing commitment to minimum environmental impact and sustainability (successful recycling and reuse scheme for contractors' plasterboard and plaster block waste, maximum use made of recycled materials within the manufacturing process of new products, optimum use of synthetic gypsum, a by-product from coal-fired power stations, board paper liner made of recycled materials, transport to plant of raw materials by tanker vessel, carrying the equivalent of 2400 tank truckloads annually).

Isolava is also a key supplier of innovatively recycled building materials (partition wall and ceiling boards) to the Belgian Recyhouse project, aiming to encourage the reuse of secondary building materials.



Isolava products and systems are widely specified on residential and non-residential new-build and refurbishment projects: housing, office and industrial buildings, hotels, healthcare accommodation



ISOLAVA

Ooigemstraat 12 | B - 8710 WIELSBEKE
T +32 56 67 44 01 | F +32 56 67 44 59
info@isolava.be | www.isolava.be



Designer heating systems...

... radiators wrapped around pillars, rounding corners, wall- or trench-mounted, recessed or free-standing, with casings made of wood, copper, natural stone conglomerate, shaped as a herringbone, or as a floral bas-relief and made of... concrete.

Let's face it: it is hard to remain one's usual objective self when trying to capture the essence of Jaga's exceptional range of heating: they're radiators, definitely... but with a difference, surely ?

The impressive Jaga array centres around 3 main ranges :

Energy Savers sustainability range (*Knockonwood, Strada, Linea Plus, Mini, Mini Canal...* series)

Low-H₂O radiators, requiring a mere 1/10 of water volume of traditional steel panel radiators, an extra 12% energy saving, substantially cutting back CO₂ emissions (as much as 1 tonne per dwelling!) and providing a constant and perfectly-controlled heating output and optimum indoor comfort.

Eyecatchers range (*Taboe, Iguana, Geo, Accolade...* series)

The radiators included in this range are true works of art, genuine gems, developed with a keen eye for detail, painstakingly designed, engineered and developed into "strikingly inconspicuous" elements of charm, blending elegantly into any setting, traditional or contemporary minimalist...

The latest addition to this range, successfully launched at the 2007 Milan Design Fair, is *Heatwave*, a wall-mounted heating "objet d'art" made of fair-faced polymer concrete and shaped as a baroque flower design. Its modular build-up allows a combination of up to 6 heating elements to make up a custom-sized, extraordinarily decorative radiator.

Top Performers range

Central to this range of compact radiators is a winning combination of Jaga's advanced low H₂O heat exchanger technology and its equally revolutionary DBE (Dynamic Boost Effect) technology of intelligent, dynamic, microprocessor-controlled miniature thermal activators, resulting in slim, but astoundingly powerful radiators, providing a 9 times faster temperature delivery and uniformly spread room comfort.

The *Oxygen, Brise* and *Clima Canal* series are multi-purpose low H₂O radiator units, which fully integrate heating, cooling and indoor climate ventilation.

They comply with the latest EU guidelines on energy performance and indoor climate regulation, as with the EN442 standard governing "radiators and convectors".



Corporate brand: *Jaga*

Branded ranges: *Top Performers, Energy Savers, Eyecatchers*

Series: *Taboe, Iguana, Geo, Accolade, Oxygen, Brise* and *Clima Canal, Knockonwood, Strada, Linea Plus, Mini, Mini Canal...*



The Netherlands, Russia, Australia, Spain, Cyprus, Poland, Azerbaijan, Norway, Armenia, Sweden, Georgia, Lithuania, Greece, Portugal, Lebanon, Bulgaria, New Zealand, Croatia, Slovenia, Hungary, Estonia, Iceland, Latvia, Romania, Ukraine...



Eastern Europe and former CIS countries, USA, Canada



Architects, consulting engineers, project developers, real estate investment companies



Presence at all major HVAC- or building-related tradeshows: Bouwbeurs (Utrecht), Batibouw (Brussel), Climatización (Madrid), ISH (Frankfurt), Construmat (Barcelona), BAU (Munich), Interbuild India (New Delhi), Americana (Montreal), Aquatherm (Moscow), M&E Building Services Event (London)...



JAGA



Set up back in 1962, only in the last 2 decades has the Jaga company developed in earnest into an accepted industry standard in heating, with a raft of innovatively designed heating solutions to its name, some of them enjoying iconic status.

“Jaga, the radiator factory”?
An understatement, if ever you saw one...

Jaga clearly has no intention to be known as just another heating manufacturer, more as a culture, one of creativity, combining innovative technologies, materials, manufacturing techniques and product lines providing better, faster, cleaner, healthier and environmentally-conscious heating solutions.

Invariably, the company brings the design element into a concept as straightforward as heating. So, expect no cold, mass-produced heating appliances, but heart-warming, aesthetically pleasing works of art. Furthermore, Jaga also pursues a consistent corporate policy of social responsibility, sustainability, eco-efficiency and environmental awareness.

Jaga's Experience Lab, where virtually any climate condition can be simulated and experiments are conducted, involving new and eco-friendly technologies, also features as a unique venue for visitors to experience at close quarters Jaga's high-tech heating solutions and for engineers, designers and creative minds to interact, float new design concepts, exchange artistic ideas, to discuss innovative technologies, applications, business opportunities...

Jaga's heating solutions have won an increasing number of specifications in prestigious projects like the Moscow Federation Tower, Telefonica HQ (Madrid), Russian Presidential Palace, the Strasbourg European Parliament Building, the Budapest Grand Hotel Royal, Aufschalke Football Stadium (Gelsenkirchen), Forum Palace (Vilnius), Lighthouse Office Building (Prague), Riga Airport (Latvia)...

Some of Jaga's designs have made it to permanent museum collections and have won scores of prestigious design awards.

Among its prize-winning creations are Iguana, Strada, Geo, Knockonwood, Linea Plus with prestigious nominations and awards to their name: IF Design Award, IF Top 10 Design Award, Design Plus Award, Design Top 100 Manufacturers Award, Paris Trophée du Design, European Community Design Prize, VIZO tri-annual Design Competition. The company also won the 2002 Flanders Lion of the Export Award for best export performance.

The company's visionary approach to establishing a creative economy leads it to involve in a variety of sponsorship activities and creative networking events (e.g. Burning Man Festival, Jaga Mood Factory, Jaga Creativity Award...), commissions to promising as well as established creative minds, who are given maximum designer freedom.

Dedicated websites, teeming with information:

www.theradiatorfactory.com

www.jaga.tv

www.jagareferences.com

www.jagaexperienclab.com

www.uchronians.org



Commercial residential and institutional projects, large-scale office buildings (especially glass-fronted ones), multiple housing projects or high-end part of single-housing market

JAGA

Verbindingslaan z/n | B - 3590 DIEPENBEEK

T +32 11 29 41 11 | F +32 11 32 35 78

export@jaga.be | www.theradiatorfactory.com

Canal Compact under-floor

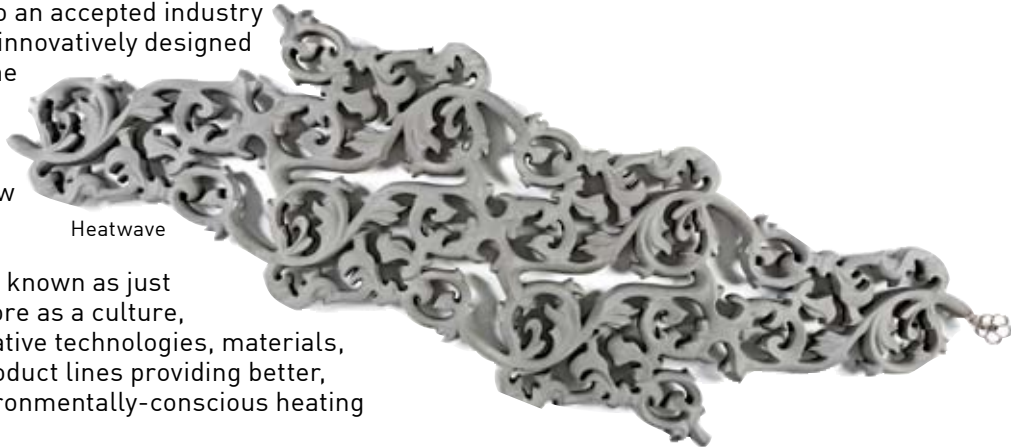

Knockonwood free-standing



JANSEN PRODUCTS

MEMO

Raised access flooring...

...consisting of a grid of proprietary adjustable pedestals - catering for various finished floor heights - and a range of flooring panels of varying construction design: panel core materials are either high-density chipboard, calcium sulphate or with a fully steel- encapsulated core. Panels are available with aluminium or steel sheet underside coverings and a wide range of factory- applied finishes: melamine-coated, vinyl, pvc, lino, carpet, timber or laminate flooring, rubber or any other finish available in conjunction with raised access flooring...

All panels achieve the highest building performance levels regarding fire resistance, acoustic properties, point load strength and electrical conductivity...

Standard panel size is 600mm square (with custom sizes available on demand), with thicknesses ranging from 38 down to 28 mm. Comprehensive range of optional factory accessories and ancillary fit-out items (precut access apertures, floor terminals, pass-through units, grummetts, vented panels...)

The versatility of a *Jansen Products* flooring system allows it to be successfully integrated in newbuild and refurbishment projects in many areas of application: general office areas, computer and switchrooms, server farms, laboratories, hospitals, clean rooms, conference rooms, exhibition halls, atrium spaces, reception and storage areas...

More... *Gipso-plus* factory-engineered, preformed drywall plasterboard elements for interior decoration (milled corner profiles, lighting coves, mouldings, columns...), including the patented *TC-90* steel-reinforced prefab corner profile and the *DK-1* plasterboard element with integrated reinforcement edging profile

Jansen Products, Gipso-plus

35 countries worldwide (Europe, CEE countries, Far East)



®

🌐

JANSEN PRODUCTS



Worldwide marketing effort ongoing or under way in UAE, US...



General building contractors, specialist flooring and fitting-out contractors, architects, developers of large-scale and medium-sized property projects, consulting engineering firms



Big 5 (Dubai), Mosbuild (Moscow), Interbuild (Birmingham), Construmat (Barcelona), Bau (Munich), Bautech (Berlin)



Drawing on 30 years of frontline experience as a fitting-out contractor, the *Jansen Products* company, part of the Belgian vertically-integrated *Jansen Group* of specialist building contractors, has evolved into a major international provider of flexible, cost-effective, high-quality raised flooring solutions for the new build and refurbishment markets.

Backed by unparalleled technical savvy, cutting-edge manufacturing equipment, comprehensive design assistance and early-stage project involvement through to the turnkey completion of the property, the company is fully committed to the highest quality standards: precision construction, dimensional accuracy, rigorous laboratory-testing of all raw materials and end products, all of which fully comply with the stringent British PSA/MOB standard and with the harmonized European EN12825 specification requirements on raised access flooring.

Impressive portfolio of successfully completed projects: Exaltis-La Défence (Paris), Presidential Press Centre (Russia), Rondo 1 (Poland), IBM UK, Capricorn Tower (UAE), Euroblok 2 (Brussels)... are just some of the showpiece property development schemes featuring Jansen Products' systems



Project markets

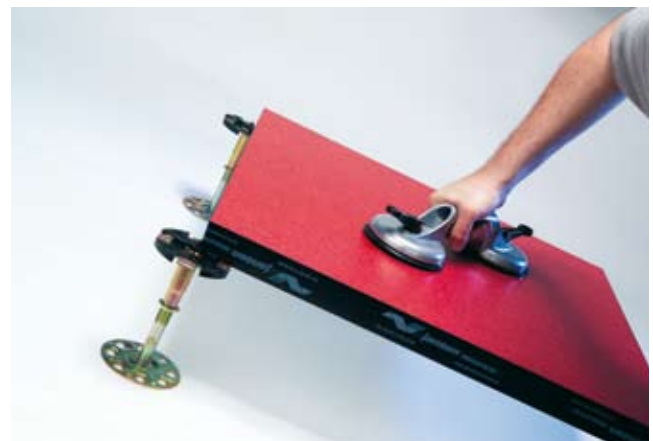

JANSEN PRODUCTS

Fabriekstraat 4 | B - 3670 MEEUWEN

T +32 11 79 33 00 | F +32 11 79 33 01

info@jansenproducts.be | www.jansenproducts.be



Precast structural concrete components

1. lattice girder concrete composite floor units
2. twin-walled concrete panels incorporating lattice girder reinforcement

The *Kerkstoel 2000+* crosswall/slab construction system consists of a permanent formwork of precast concrete floor and twin wall panels in conjunction with an insitu ready-mixed concrete topping and filling.

It is a tried and tested construction method, offering factory accuracy and speed of on-site erection, reducing on-site labour levels and concrete casting programmes, and therefore improving cost-effectiveness.

Optimum customization: all panels are made-to-measure to suit any architectural design specifications.

Available in a broad range of custom dimensions, with cast-in conduits, recesses, pre-installed service entries, door and window-shaped formwork, with a fair-faced finish or ready for any subsequent decorative finish the panels achieve high levels of structural, thermal, fire, acoustic and aesthetic performance.

Kerkstoel, Kerkstoel Beton

Belgium, the Netherlands, Luxembourg, France, Spain, UK, Ireland

UK, Ireland, Denmark, Norway, Sweden, Finland, Switzerland

Major civil engineering companies, general contractors and industrial building contractors

Interbuild (Birmingham)

Set up as far back as 1902 as a local contractor and builders' merchant, *Kerkstoel 2000+* has developed into one of Europe's leading manufacturers of precast concrete components, drawing on a vast experience and know-how, constant investment in innovation and state-of-the-art manufacturing equipment.

All components are manufactured to the most rigid quality standards (ISO 9001:2000, BENOR, KOMO);

Comprehensive technical support: early involvement in design and specification process, detailed layout drawings, just-in-time delivery, on-site coaching...;



KERKSTOEL 2000+

Preferred systems supplier to a number of challenging residential and commercial engineering schemes, both at home and abroad: e.g. a number of UK projects by Laing O'Rourke (London Imperial College, Newcastle Freeman Hospital, the Liverpool Paradise Project, with no less than 22,000 m² of precast walls and 100,000 m² of floor units supplied!) and some high-profile Irish property developments like the Belgard Square shopping mall and 382 apartments and the Maynooth scheme, involving 191 apartments and a mall as well;

The company's subsidiary, *Kerkstoel Beton*, is an accredited supplier of (specialty) concrete and other cementitious products (mortars, screeds, dry grouts...)

Residential/domestic housing: division walls, external walls, cross walls, outer face walls, staircases, lift shafts...



Industrial and civil engineering (storage facilities, tunnels, retaining walls, underground parking areas, water-retaining structures (cellars, reservoirs, swimming pools, water treatment plant...)



KERKSTOEL 2000+

Industrieweg 11 | B - 2280 GROBBENDONK
T +32 14 50 00 31 | F +32 14 50 22 48
info@kerkstoel.be | www.kerkstoel.be

Precast concrete products...

... for a variety of construction purposes:

- **drainage:** gullies, sewage pipes (reinforced or non-reinforced), manhole sections and inspection chambers, attenuation basins...;
- **road/motorway construction and hard landscaping:** street paving blocks, roadside kerbing, road restraint and traffic management systems...;
- **hydraulic engineering:** sea walls for coastal protection, bridge face walls, precast concrete revetment and sheet piling elements for channel linings, shore protection, slope stabilisation and embankment reinforcement;
- **transport and utilities:** tramway level crossing panels, street lighting poles and phone masts, transformer huts, turnkey garage units.



France

UK, Algeria

Agents, consulting engineers, local government procurement agencies

As a trade visitor: Bauma (Munich), Batibouw (Brussels), Batimat (Paris)

As an exhibitor: Matexpo (Courtrai-Belgium), Tedewest (Roeselare-Belgium)

Lithobeton is a second-generation, family-owned company, boasting over 60 years' experience in the precast concrete business. Over the years, it has developed into one of Belgium's leading manufacturers of factory-engineered precast products for use in a broad range of construction and civil engineering applications.

At its 2 production sites, a comprehensive standard range of speciality products is manufactured, complying with the latest technical standards and meeting the most stringent quality assurance requirements (e.g. BENOR product certification). The company also operates a design service for special bespoke precasts of all types and manufactures them to customer specification.

This flexibility, combined with a vast manufacturing experience, has won the company solid references and preferred-supplier status with public utility companies, civil and hydraulic engineering contractors, public transport operators...

Member of the Flanders Concrete cluster of concrete-processing companies (www.flandersconcrete.com)

Mainly project market (utilities and public works)

LITHOBETON

Kanaalstraat 18 | B - 8470 SNAASKERKE
T +32 59 27 60 60 | F +32 59 27 65 03
info@lithobeton.be | www.lithobeton.be





Custom-built concrete mixing and batching plant

Versatile range of high-capacity concrete plant, entirely designed and built in-house to the most exacting technical standards, specific site requirements and specifications from customers operating in the ready-mixed and precast concrete industries and concrete civil engineering contractors, undertaking airport, motorway and tunnelling projects (for jobsite pouring).

Some of the major operational benefits offered by a *Mengco* plant are its modular design and construction, allowing swift transport, shipment, rapid on-site erection, easy configuration of additional processing units and maintenance.

The range comes with a choice of mixer types, various discharge outputs (ranging from 20 up to 480 m³ depending on the plant type), various transit-mixer truck driveway options or batching facilities, types of aggregate feeder systems, mains or generator-powered, "winterised" or adapted to other inclement climatic conditions...

Only premium-quality materials are used, guaranteeing reliable, long-life operation of the equipment: quality steel aggregate bins, broad range of corrosion-resistant coatings, up-to-the-minute technology incorporated in all plant designs (microwave moisture measuring systems, high-accuracy weighing equipment, full diagnostic and follow-up trouble-shooting tools ...), computerized process controls, all allowing highly-automated, single-operator control.

More... Specialist minerals batching plant for environmental and soil stabilisation applications (Bentonite, Trisoplast)



Europe, Middle East, Russia, US



Global marketing effort ongoing



Companies operating in the precast and ready-mix concrete industries Concrete civil engineering contractors involved in projects, requiring on-site batching and mixing plant



Drawing on over 90 years of specialist experience, expertly supported by a well-resourced, in-house R&D team and a highly-skilled technical drawing department, *Mengco* now is internationally valued for its reliable concrete batching and mixing plant by numerous international customers, featuring some of the world's leading suppliers of ready-mixed concrete (Italcementi, Holcim, Hanson, Tarmac...) and on some quite high-profile airport expansion projects (Heathrow, Gatwick, Schiphol, Moscow, St. Petersburg). Member of the Flanders Concrete cluster of concrete-processing companies (www.flandersconcrete.com)



Industrial and civil engineering markets



MENGCO



MENGCO

IZ Klein - Gent Atealaan 38 | B - 2200 HERENTALS
 T +32 14 28 20 20 | F +32 14 23 16 35
info@mengco.be | www.mengco.be

METROTILE EUROPE



Lightweight steel roofing panels (“tile, shingle or shake-effect”)

MetroBond®



Compared to the traditional roofing materials the look of which they strikingly recreate, Metrotile tilesheet panels provide lightweight strength and durability, featuring a number of undeniable benefits: weight-saving (just under 7kg/m²), they allow easy hidden dry-fix installation, while at the same time saving transport, storage space and reducing on-site labour. They are also UV, fire and weather resistant (even in the harshest weather conditions: heat, frost/thaw, wind lift), inhibit moss and algae growth and require hardly any maintenance.

All Metrotile panels are formed from 55/45 aluzinc alloy coated high-grade steel with a 0,45 mm or 0,9 mm thickness - i.e. the 900 range for vandal proof strength -, covered with a 100% acrylic resin basecoat embedded with natural rock granules and a clear acrylic overglaze. Apart from a stone-coated surface finish, smooth prepainted versions are also available.

Widely used in new-build roofing projects and roof refurbishment jobs alike, including reroofing, over-roof coverings, flat-to-pitch roof conversions..., Metrotile lightweight roofing panels allow architectural design freedom on all types of roof-build-up, from vertical cladding down to 15 or 10° pitch roofs, depending on the type of tile profile used.

In addition to its classical *MetroBond* and *MetroClassic* tile profile range, Metrotile also offers the mediterranean-style *MetroRoman* panel, the shake and shingle profiles (*MetroShake* and *MetroShingle*), which both closely resemble these traditional wooden roofing materials without the downsides of splitting, warping and increased fire risk. New to the range are the large-size “5 tiles by 4” *Multibond* panels. The entire product portfolio comes in a broad standard colour swatch, with additional factory-approved colours available to order).

Complementing the range is a vast array of over 100 accessories and ancillary items, custom-made and in perfectly matching finishes: trim tiles, ridges, bargeboards, flashings, hips and valleys, translucent tile panels, soil and vent tile adaptors, end caps...).

The product range is backed by an unparalleled 30-year weatherproof warranty and a documented 40-year lifespan. Metrotile products also hold multiple seals of approval (e.g. ATG, BBA, ITB Poland, ESR (US), CSTB, BRANZ appraised, DIN 4102 fire rating...), issued by a host of international certifying bodies.

More... easy-to-assemble steel structural roofing support system compatible with the entire Metrotile

MetroBond, MetroClassic, MetroRoman, MetroShake I and II, MetroShingle, Multibond



Ongoing consolidation of existing markets across Europe, the Middle East, CIS states and Africa



Marketing efforts initiated in a number of African, Middle Eastern and Asian markets with as yet untapped market potential (Egypt, Iraq, Tunisia, Libya, India...)



MetroShake®



MetroBond®

METROTILE EUROPE



Distributors of building materials and roofing, builders' merchants specializing in roofing materials



Regular sales presence at most major international construction fairs: Dach und Wand, Batimat, Bati-bouw, Bau, Mosbuild, Rebuild Lebanon... Regional-scope fairs exhibited at or visited by local business partners



Since production started at its Belgian purpose-built, ISO 9001 certified state-of-the-art manufacturing plant in 1998, Metrotile Europe, part of the Metrotile group of companies, which operates globally and has manufacturing plants in New Zealand, Belgium and the US, has made it to its current status as a leading manufacturer of high-quality lightweight roofing tilesheets.



MetroShingle®

Its outstanding export performance - achieved in just 10 years of existence - currently amounts to a hefty 98,5% of total output and is the result of a company policy mix, consisting of stringent quality control, constant product development, future-oriented investments in high-tech manufacturing equipment and process automation. The company's well-conceived international marketing concept combines a network of sole distributors of proprietary Metrotile products and independent multiple-brand distributors.

Backed by in-house know-how, R&D, tooling,



MetroRoman®



engineering and manufacturing skills and expert knowledge, shared with its associate companies overseas, the company puts into practice a market-driven policy of innovative product research and development.

Recent additions to the range include the 2005 Mediterranean *MetroRoman* tilesheet, the 2006 *Multibond* large-size panels, aimed at the modular park home or relocatable building markets, with other tile profiles forthcoming: large-size *MultiShingle* panel or the interchangeable *MetroShingle* line, targeted at the market segment of garden outbuildings). Equally innovating is the company's granular stone coating process with moss-growth inhibiting properties and its improved dual-component coating process.

The company's outstanding international trade performance has won it the 2005 *Golden Bridge Best SME Award* for its trade record on the UK market and a nomination for the 2006 *Flanders Lion of the Export Award* for Best Export Performance.

Metrotile Europe provides business partners and customers with comprehensive technical and commercial support. Through its Metro Consult international sales advisory team, consisting of all major business partners, the company promotes closer involvement in corporate decision processes, strategic development, R&D, innovation, marketing, product and service improvement, sustainability...

As many as 10 Metrotile business partners in key export markets all have multilingual dedicated websites, featuring comprehensive product literature for roofing contractors, architects, specifiers and home-owners.



MetroShake®II



Residential dwellings, commercial and public access buildings...

METROTILE EUROPE

Heesterveldweg 15 I.Z. Oost | B - 3700 TONGEREN

T +32 12 24 18 01 | F +32 12 24 18 02

info@metrotile.be | www.metrotile.be





Moulded clay facing bricks

Encompassing array of some 50 brick varieties in as many distinctive colour shades, each with a charmingly irregular shape, and a delicately sanded creased surface texture. Some standard brick types can be manufactured in up to 7 different sizes.

Using meticulously balanced mixtures of quality löss clay excavated from a nearby company-owned site, the *Nelissen* company's purpose-built, state-of-the-art manufacturing equipment simultaneously produces up to 5 shades of varying colour bricks in one go. The entire product range is CE-marked, conforms to the stringent EN 771-1 standard for clay bricks and carries the BENOR quality label ("F2 highly frost resistant"). The company operates an ISO 9001 certified quality monitoring system.

More... broad standard range of matching hand-moulded brick specials: brick slips, angle, cant, bullnose bricks, plinth, capping, pistol and bonding bricks (non-standard specials are made to order).

Nelissen Handvormgevelstenen

Czech Republic, Estonia, France, Germany, Ireland, Italy, Japan, Lithuania, the Netherlands, Poland, Sweden, UK

Ongoing international market research effort

Importers, distributors, agents, architects, specifiers, consulting engineers, contractors, (turnkey housing) project developers

Budma (Poznan), Nordbat (Lille), Building Partnering Days (the Netherlands - various venues), Batibouw (Brussels), BIS (Ghent), Bouwinnovatie (Hasselt), Batimoi (Marche-en-Famenne), Habitat (Liège, Ciney)

The 100% family-owned *Nelissen* brickworks started life way back in 1921. Currently, the company boasts an annual production capacity in excess of 150 million moulded facing bricks, with an average of 10,000 finished dwellings a year.

Innovative product development, resulting in regular releases of new brick varieties (e.g. the appealing *Rodruza* line of white and greyish shaded Westerwald clay bricks) or exclusives like the traditional *Baekelsteen*[®] brick series, with a precut joint, allowing variation in bond patterns.



NELISSEN

Facing bricks by *Nelissen* meet all building requirements for new build, restoration or extension and are specified both for external cladding and for masonry used as an internal finish.

Successfully finished reference projects, featuring:

- landmarks (e.g. the Yser Tower Great War Memorial, the Brussels Couckelbergh Basilica);
- football and sports stadiums (e.g. the Brussels King Baudouin stadium and the Anderlecht and Standard de Liège football stadiums);
- high-profile commercial and government buildings (e.g. Wijnegem Shopping Centre, Limbourg Province House...);
- a great many other building developments.

At the company's Brick Library, the entire brick range can be viewed on ceiling height masonry wall units and its well-crafted 4-language website features the entire product catalogue with comprehensive technical briefs and a handy masonry visualization tool with 6 colour mortar joint profile options.

Residential, public and commercial projects



NELISSEN

Kiezelweg 460 | B - 3620 KESSELT-LANAKEN
T +32 12 44 02 44 | F +32 12 45 53 89
info@nelissen.be | www.nelissen.be

NEOFIBRA



Extruded wood plastic composite (WPC) decking boards

This easy-to-install decking range is available in 5 nature-inspired shades, various section lengths, allowing single spans from 2 to 6 metres (longer sections available on demand) and a broad range of accessories: matching joists, proprietary mounting clips for hidden fastening, fascia boards and trim caps.



Decodeck (professional market) and *Xtradeck* (private market)



The whole of Europa and the CEE countries



Ongoing marketing effort throughout Europe, CEE countries and overseas

Decodeck range: importers, wholesalers, distributors supplying builders' merchants and the timber trade, the landscaping project market, architects, specifiers

Xtradeck range: DIY chains, garden centres



Batibouw (Brussels), Green Expo (Ghent-Belgium), Spoga+Gafa (Cologne)



The Decodeck-Xtradeck decking systems are the first of what is to become a range of innovative ecological WPC materials pioneered by the *Neofibra* company, part of the Belgian *Iplast* thermoplastics processing group of companies. Its decking range now boasts an impressive track record of numerous high-profile references throughout Europe.

WPC decking provides a great alternative to solid hardwood decks, offering the same glorious look and feel of naturally weathered wood, but scoring a number of benefits over it: no warping, rotting, splintering or cracking, low maintenance, no painting or staining required, lasting durability, resistant to moisture and insect damage, slip resistant

Comprehensive warranty coverage: 10 years against damage from rotting, splitting, splintering or fungal decay. An exceptional 5-year warranty is granted against excessive discolouring. The material was fiercely age-tested and exposed to accelerated weathering in a laboratory environment.

Environmental sustainability: *Decodeck-Xtradeck* boards are made of WPC, a well-balanced mixture of reclaimed waste wood and plastics (polyolefins), contain no toxic chemicals or preservatives, are fully recyclable at the end of their life-span and eventually contribute to halting deforestation.

Well-designed and highly-informative system-dedicated websites.



Professional/project and the private markets



NEOFIBRA

Roosevelttlaan 172-174 | B - 8790 WAREGEM
T +32 56 62 70 20 | F +32 56 62 70 29
info@decodeck.com | info@xtradeck.be
www.decodeck.com | www.xtradeck.com

NORDAL



Reconstituted garden paving flags

Nordal's product range includes:

the *Flagstone* paving range, available in 3 true-to-nature hues (blue stone, ocre and cream), in a combination of 3 sizes (440 x 440, 440 x 220 and 220 x 220 mm) for random laying or in a 2, 3 or 4-ring circular pattern with squaring-off kits and corner sections to blend the circle into a larger patio area;

Ton Pierre, available in 5 sizes (300 x 450, 450 x 450, 450 x 600, 600 x 600 and 600 x 900 mm) and in 2 premixed intricate random patterns, using either all 5 sizes of flags or just the 3 smaller ones;

Moon step paving: stepping stones, shaped as a partially eclipsed moon disk, ideally suited for pathway paving in colours matching the standard paving range

Pool-edge coping stones (curved, corner and straight sections) and poolside paving (cream-coloured)

Flagstone, Ton Pierre, Moon

The Netherlands, Germany, France, India

Austria, Denmark, Finland, India, Ireland, Norway, Sweden, Switzerland, UK

Builders' merchants wholesale trade, DIY chains, landscape architects and garden landscaping contractors...

Precious standard range of high-quality precast reconstituted garden paving, faithfully replicating genuine natural stone flags and stylish in both contemporary and traditional garden settings.

Customer-oriented and innovative product development: the *Moon* pathway stepping stones and the pool-edge coping stone range. Bespoke development of paving solutions for one-off hard landscaping schemes.

Detailed pattern outlines, laying and pointing instructions are included in every pack delivered.

Residential and light commercial applications

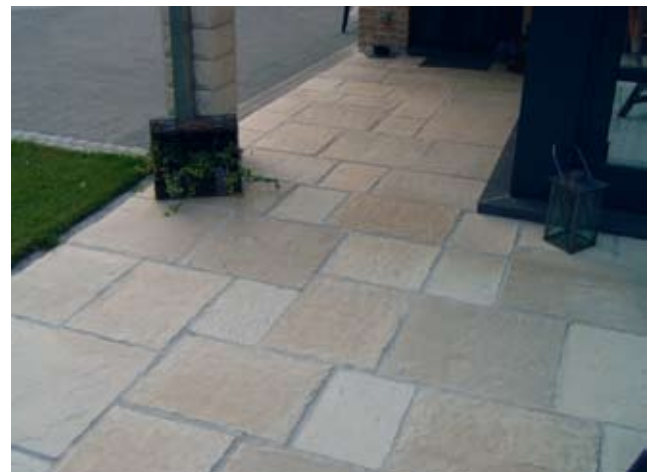

NORDAL

I.T. Kanaal Noord 1101 | B - 3960 BREE
T +32 89 70 48 18 | F +32 89 47 23 73
nordal@skynet.be | www.nordal.be



Reclaimed appearance facing bricks

Unique luxury range of 33 types of exclusive reclaimed appearance facing bricks, protected by a European patent and a registered trade name.

Specifying new bricks with a reclaimed appearance instead of genuine "reclaims" offers the advantage of them being manufactured to an established standard as regards strength, frost resistance, water absorption, colour-fastness..., whilst adding just as much style, individuality and character to a new-build, refurbishment or restoration project.

More... (genuinely) reclaimed bricks and custom-made natural stone architectural stonework (made of Belgian blue and French white limestone): hand-carved building ornaments, door and window surrounds, cantilever beams, copings, lintels, window sills, plaques, letter boxes...



Olivier company brand (along with a range of registered brick trade names eg. *Beers klompje*®, *Doornikse klinker*®, *Damse Abdijmoef*®, *Delftse Rijnvorm*®...)



the Netherlands



France, UK



Agents, importers, builders' merchants, architects, building and roofing contractors



Batibouw (Brussels), BIS (Ghent-Belgium), Nordbat (Lille), Internationale Bouwbeurs (Utrecht)



About 60 years of experience in the building materials trade and extensive know-how in brickmaking has turned Olivier into a household name in Belgium and the neighbouring construction markets.

Testament to a dynamic product development and customization policy, the company's cutting-edge manufacturing plant regularly turns out new simulated reclaimed brick varieties and its development-to-commission service allows customers to have their own type of brick made to their exact colour specifications.



OLIVIER

Part of the *Olivier* group of companies, involved in construction and civil engineering and incorporating companies as diverse as a brick manufacturer and distributor of clay roofing tiles, a builders' merchant, a specialist precast concrete manufacturer, a sheet-piling and underpinning contractor, a natural stone wholesaler and a company specialized in distressing and ageing natural stone;

The company runs 2 showroom facilities: one at the Belgian factory site and one at its sales office in the Netherlands (www.olivier-nederland.nl)



High-end residential projects (new-build, renovation and refurbishment)



OLIVIER

Izegemstraat 84 | B - 8800 ROESLARE-RUMBEKE
T +32 51 26 52 68 | F +32 51 26 52 67
olivier@olivier.be | www.olivier.be

High performance liquid-applied elastomeric PU waterproofing coatings

Waterproofing coatings for balconies, terraces and communal walkways:

multi-layer system curing to form a seamless waterproof membrane, consisting of a cold/liquid applied polyurethane-based waterproofing coating, with embedded glass-fibre reinforcement scrim and various finishing options: the Quartz screed surface finish, with premixed coloured quartz aggregate mixed into a transparent PU glaze coating or the Deco finish, involving a sealed decorative paint chip mixture or with a Tile Adhesive top coat ready to receive a tiled finish.

Prime advantages: ease of application (brush/roller or airless spraygun- applied without unnecessary disruption to the substrate), great performance characteristics: crack bridging, vapour permeable, skid and wear resistant, zero flame or heat application (reduced fire risk), aesthetic finish, longevity...Cold/liquid applied roof coating compounds, curing into a seamless, elastomeric, vapour permeable waterproofing for roof areas guaranteed to last for 10, 15 or 20 years before first maintenance.



Concrete repair and protection coatings: cementitious repair and smoothing mortars, high-performance anti-carbonation coatings based on the latest advanced technologies in polymer, fibre reinforcement, microsilica concrete and innovative cementitious materials

External wall protection and weatherproofing: broad range of elastomeric waterproofing coatings, crack bridging, hard-wearing and vapour permeable, fast-curing, providing anti-carbonation protection and resistance to acid attack, preventing the growth of moulds, fungi and algae, colour stable (plain transparent or decorative textured finishes)

Hygiene coatings for applications on to internal walls and ceilings in demanding hygiene-sensitive environments (healthcare, pharmaceutical industry, laboratories, clean rooms, food processing...). These surface coating systems are non-leaching and anti-microbial, crack bridging, easy to (pressure-)clean, resistant to abrasives and cleaning agents, vapour permeable and they tolerate thermal movement.

Asbestos encapsulation sealants...

Range of high-performance coatings for the in-place management of asbestos, either through impregnation/sealing or by encapsulation

...and fire-retardant coatings: these coatings boast the highest fire safety ratings to international standards and offer outstanding protection against fire propagation, chemical attack, moisture and aging degradation of the substrate along with an exceptional impact/shock resistance, by virtue of which they are widely used for both industrial and military purposes.



PENTAGON PLASTICS

® Balcony waterproofing: *Decothane Balcons (Deco, Clearglaze Kwarts, Tile Adhesive)*
Roof coating : *Decothane EC, Decothane SP, Decothane RR* (root resistant grade as part of a green roof system)

Concrete repair and external wall weatherproofing:
Monomix RM21, Decadex New, Monolastex (RE and 2000), Decothane Clearglaze Walls, Isoclad PCM, K154, K501
Hygiene coatings: *Steridex D, Sterisheen, Sterisept, Sterisheen Deco, PP Biowash, PP Biocleanse*
Fire retardation and asbestos encapsulation:
Firecheck, Fibrelock



🌐 Luxembourg, France, the Netherlands, Switzerland, Croatia, Czech Republic, Germany, Austria, Serbia, Montenegro, Slovakia, Hungary, Poland, Slovenia

👁️ Market consolidation and further marketing effort ongoing

👤 Waterproofing and speciality coating products specifiers, quantity surveyors, architects, agents, distributors, waterproofing, consulting engineers, contractors

🏛️ Nordbat (Lille), ISPE Conference (Zurich)

👤 Pentagon Plastics nv is part of the IOtech group, an association of four companies based in the UK, the US and Belgium. The latter is located in Nazareth is supported by an international network of agents and distributors in parts of the European mainland.

Since its foundation in 1974, Pentagon Plastics has left its mark on the professional waterproofing business as an established manufacturer of high-quality waterproofing systems for balconies, roofs and external walls, along with other technologically advanced coatings (hygiene, fire-retardant, asbestos containment).



The entire product range holds multiple certification, authoritative endorsement and gleaming test reports from various international test bodies (ISO 9001:2001, Belgian BUTGB/ATG, UK BBA, German MPA NRW, NORISKO and APSEL (France), ITB (Poland), EU ETAG 005, various public health authorities...)

Coupled with a vast amount of in-house expertise, the company's R&D team is driven by a problem-solving attitude, resulting in application-specific product development and improvements in some of the most demanding high-specification niche markets. The company also offers competent technical guidance and data sheets, detailed application techniques on-site assistance and professional training and other parties involved in the waterproofing or specialist coating business. Pentagon Plastics' products and systems have been globally specified by such companies of international renown as BASF, BBC,

Beck's, Carlsberg, ICI, Ford, Interbrew, Johnson & Johnson (Div. Janssen Pharmaceutica), KPN, Kraft Foods, Lactil, Pfizer, Renault, Shell, Sheraton, Volkswagen. the Birmingham National Exhibition Centre...

👤 The renovation, rehabilitation and refurbishment part of the residential, industrial and public utilities markets

PENTAGON PLASTICS

Venecoweg 37 | B - 9810 NAZARETH

T +32 9 381 65 00 | F +32 9 381 65 10

info@pentagonplastics.com | www.pentagonplastics.com

PLASTIVAN

MEMO Decorative wall and ceiling panels from UPVC: printed or laminated

Plastivan offers a broad range of plastic panels for use in homes as well as public utility facilities. These colour-fast panels are tough, long-lasting and suitable for damp rooms.

Plastivan's product lines of printed mouldings offer such choices as white high-gloss, ash woodgrain effect, brush painted style, marbled effect, etc.

The ranges of laminated panels cover an equally wide spectrum of patterns, a number of them with joining mirror strips.

Colour-matched finishing profiles are available for all ranges.

Plastivan's decorative cladding panels can be fitted using nails, staples, screws or glue, and are available in three lengths: 2.70 m, 4.50 m and 6 m.

More... UPVC gutter systems, internal window-sills, industrial profiles, roller shutters, external building products such as fascias, soffits and wood plastic composite decking

MEMO Batimat (Paris), Budma (Poznan), DIY (Courtrai), Interbuild (Birmingham)

MEMO Four decades of innovation and rapid growth have helped make *Plastivan* a European leader in the UPVC mouldings market, with branches in Belgium, France, England and Poland. Its subsidiary *Extrumat* is a metalworking company dedicated to the manufacturing of made-to-measure extrusion tools for PVC profiles, both for *Plastivan* and for third parties (contact through info@extrumat.com).

MEMO *Plastivan* products are distributed throughout Europe, Russia, Ukraine...

MEMO Wholesalers of PVC products, retailers of wood and building materials, DIY retailers and construction companies will be pleased to note that *Plastivan* takes special pride in operating a strict delivery scheme.

Plastivan boasts a comprehensive range of sales and marketing support products.

MEMO Residential and contract markets

PLASTIVAN



PLASTIVAN

Wanestraat 31 B - 8780 OOSTROZEBEKE
T +32 56 66 75 51 | F +32 56 66 91 18
info@plastivan.com | www.plastivan.com



Gypsum blocks for non-loadbearing internal applications (partitioning and infill walling)



The Promonta company offers an impressive range of solid gypsum blocks, factory-moulded with an interlocking tongue and groove edge detail, for accurate and seamless bonding. The range consists of three standard block varieties:

- the “regular” block type, available in a variety of thicknesses (ranging from 50 to 100 mm) and dimensions (including small-sized 18 kg building blocks, complying with stringent Dutch legislation on working conditions)
- high-performance blocks (like the *Promonta Heavy* high-density blocks for superior acoustic performance, enhanced surface hardness or increased overall strength) and
- the *Promhydro* water-repellent blocks with low humidity absorption, and therefore ideally suited for wet areas



Complementing the standard range, are special-shaped blocks (e.g. quarter-round blocks for spiral staircases and half-round fillet blocks for rounding off corners, cladding columns or other curved partitioning designs...) and a broad array of accessories and ancillary items (joint filler, finishing plaster, gypsum lintels, U-channel sections, damp-proof membrane sheeting, foam strip sealants...)

The *Promonta* solid gypsum block internal partitioning system provides unconstrained flexibility in internal design and in terms of future modifications to the interior layout of the dwelling.

The system also scores on various counts over alternative partitioning options (stud partitioning for instance). Among its most common benefits are: fast-track installation (3 standard blocks to 1 m³), a fair-faced surface factory finish, requiring no further decorative finish by follow-on trades, superior thermal properties, an excellent fire performance record (up to a 4-hour fire resistance for 100 mm blocks), outstanding

acoustic properties (especially when using the proprietary *Promagglo* blocks in a foam-insulated cavity wall set-up), great workability, easily cut and chased for incorporating services and ducting and providing a solid substrate for strong and reliable wall-mounted fixtures and fittings.



Promonta (Normal, Heavy, Promhydro, Curved, Promagglo acoustic range), Promontine and Superpromontine adhesive, Promolys finishing coat, Elasto WP12 flexible joint filler



Belgium, The Netherlands, Luxembourg, France (northern France mainly), United Kingdom, Ireland



Ireland, Portugal, Polen, India, Denmark, Switzerland, Libya

PROMONTA



Internationale Bouwbeurs (Utrecht), Afbouwexpo (Den Bosch), Interbuild (Birmingham)...



Professional construction market: contractors, architects, specifiers, builders' merchants cash&carry outlets, drywalling and fitting-out contractors



Industrial and residential buildings, public access buildings, hotels, healthcare facilities, care homes, office blocks, apartment buildings...



The Promonta company has a nearly 40-year pedigree in gypsum block manufacturing for non-loadbearing internal wall applications.

It has a rigorous quality monitoring scheme in place, both by in-house lab and independent testing and certification authorities (Belgian SECO-WTCB, Dutch KIWA...).

The entire *Promonta* product range bears comprehensive certification (CE mark in accordance with the European DIN EN 12859 Standard, Belgian ATG, Dutch KOMO, British BBA). The company pursues a consistent policy of innovative product development in close co-operation with its principal customers, drywalling specialists and fitting-out contractors...

The Promonta innovative partitioning solutions have been widely specified on a host of new-build and refurbishment projects by major Belgian, Dutch and British contractors: Besix, Louis Dewaele, Willemen, Dillen, CEI-De Meyer, Maes, CFE, Strabag, Strukton, Antwerpse Bouwwerken, T. Palm... Raab Karcher, Bouwcenter Group, Wouters Totaal Afbouw, De Bruyn Intergips... and AMEC, Laing O'Rourke, Countryside...

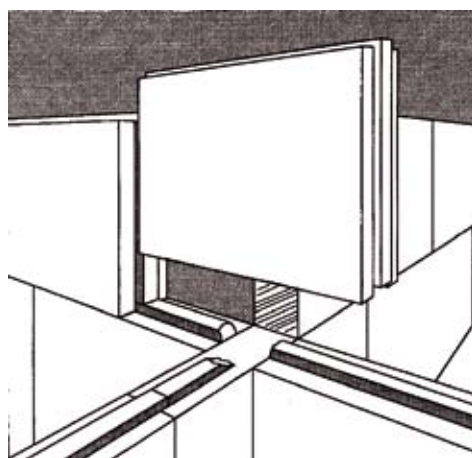

PROMONTA

Vaartstraat 6 - 8 | 2830 WILLEBROEK

T +32 3 886 58 25 | F +32 3 886 38 47

info@promonta.be | www.promonta.be

RECTICEL INSULATION



Thermal insulation boards (PIR and PUR)

The vast portfolio of thermal insulation boards made of polyurethane - PUR (*Eurothane®*) and polyisocyanurate - PIR (*Powerdeck®/Powerline®*) helps to enhance thermal performance requirements of floor, wall and roof constructions.



Main areas of application are:

- Floor insulation: for ground-supported or intermediate floors);
- Flat roof insulation: for warm flat roof designs on concrete deck or metal decks, underneath bituminous or single-ply waterproofing membranes. Also available: range of tapered insulation boards with varying slopes;
- Pitched roof insulation (sarking-type): *Powerroof®*;
- Wall insulation: for partial-fill cavity wall insulation (*Eurowall®*) and internal lining (*Eurothane® G*);
- Agricultural insulation: ceiling and wall insulation (*Eurothane® AL* and *Powerline®*) for agricultural buildings (storage rooms, sheds...).

These boards are cut to length to avoid thermal bridging.



Some outstanding characteristics these insulation boards have in common, are their excellent thermal conductivity levels, dimensional stability, high compressive strength, outstanding fire resistance performance (FM approval for the *Powerdeck®* range), light weight, extensive range of standard thicknesses, including cut-to-length (for agricultural insulation boards) and their ease of handling and cleaning.



Eurothane (BI-3, BI-3A, AL, G), Eurowall, Eurofloor, Powerdeck (F,B), Powerline, Powerroof



Sales presence in the Netherlands, France, Germany, UK, Ireland, Denmark and Poland



Ongoing strategic expansion and market consolidation in existing markets and continuing marketing effort in key target markets: Spain, Czech Republic, Denmark, Latvia, Lithuania, Turkey, UAE



Importers, distributors, major builders' merchants, architects and specifiers



Recticel Insulation is a regular exhibitor at major construction fairs: Bau (Munich), Batimat (Paris), Big 5 (Dubai), Budma (Poznan), BIS (Ghent), Architect@ Work (Courtrai), Industrie- en Projectbouw (Antwerp)



RECTICEL INSULATION



Recticel, the Belgian-based and stock exchange quoted multinational group of companies, has around 100 operations in over 25 countries throughout Europe, the United States and Japan.

The group manufactures and converts foam products for applications as diverse as bedding, automotive components, flexible foams and insulation materials. *Recticel* is definitely one of Europe's most prominent manufacturers of high-performance insulation materials. Production takes place at the company's plant in Wevelgem (Belgium).

The company operates an ISO 9001-2000 quality management system and boasts comprehensive product certification: CE mark on the entire product range, in compliance with the harmonised EN 13165 standard, additional EU-backed Keymark quality certification, ATG (B), BBA (UK) and FM (US) approval (on some ranges), the highest possible fire ratings (BS, Euroclass...).

The company sets great store by R&D and innovative product development, like the improved-formulation PIR foam "*Tau-foam by Recticel*", combining low weight, high compressive strength and outstanding fire-resistance properties, earning it specifications in a number of high-profile commercial roofing projects like the Bilbao Exhibition Centre (ES), Aldi (NL-FR-BE), Toyota (FR), Prologis (PL)...

Furthermore, the company is strongly committed to achieving the highest levels of sustainability with regard to both its product portfolio and its production technology.

Its dedicated website includes comprehensive product literature, technical manuals, thermal performance calculation aids, estimation and specification tools for insulation lay-out schemes...



The *Recticel* product portfolio caters for any thermal insulation requirements in public and private residential, commercial and industrial markets.

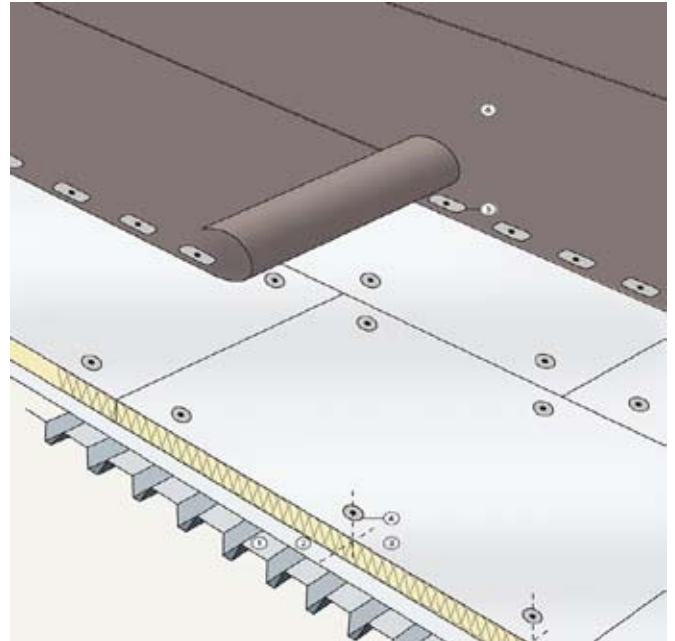

Powerdeck® on steel deck with mechanically-fixed waterproofing



RECTICEL INSULATION

Tramstraat 6 | 8560 WEVELGEM

T +32 56 43 89 20 | F +32 56 43 89 29

eurothane@recticel.com | www.recticelinsulation.com



Ventilation and solar shading systems

Ventilation systems

Renson ventilation systems deliver draught-free comfort by controlling the indoor air quality of a building.

Its vast range includes ventilators (surface-mounted on a window frame or glazed-in), louvres and continuous louver systems, transfer grilles, slot vents, extractor units... for a broad range of ventilation schemes and configurations: natural, mechanical/ powered systems and combined/hybrid systems, incorporating demand-controlled ventilation (governed by sensors measuring pollutants or humidity and occupancy levels)

Some lines are available with a number of additional properties for special applications: acoustic/sound absorbing, fire-resistant, burglar-proof, purpose-built supply and extraction vents for conservatories, heat recovery ventilators, as a combined all-in-one ventilation and solar shading system (e.g.

Screenvent® Mistral).

Solar shading systems

The external solar shading solutions prevent overheating, solar glare and provides a building with optimum natural daylighting. The range includes both solar screening systems and architectural louver systems, (e.g. the *Icarus®* or *Sunclips®* ranges for horizontal, vertically or inclined mounting, with fixed or adjustable slats, as a sliding screen...

By expertly combining the high-performance products from both its core lines of business, ventilation and solar shading, Renson designed and developed the *Healthy Building Concept*, an ecologically-sound climate control system, integrating thorough continuous background ventilation, night cooling, effective sun protection (and, for good measure, adding enhanced acoustic properties).

A case in point of this whole-building scheme is the company's Belgian head office, a landmark of contemporary design along the E17 motorway, designed and built entirely along the principles of healthy building and even removing the need for an energy-guzzling air conditioning system.

Proprietary company brand: *Renson®*
Some *Renson* system brands: *Screenvent®*, *Invisivent®*, *Linus®*, *C+®*, *Xtravent®*, *Silendo®*, *Airtop®*, *Sonovent®*, *Transivent®*, *Sunclips®*, *Icarus®*, *Loggia®*...



RENSON



Europe (Germany, France, UK, Italy, the Netherlands, CEE countries...) USA, , Australia, China



Spain, Portugal, Italy, Scandinavia, Baltic States, Russia and former CIS countries, Turkey, India



Distributors, builders' merchants, general contractors, window manufacturers, architects and specifiers



Batibouw (Brussels), Batimat and Equip'Baie (Paris), Bau (Munich), BIS (Ghent), Construmat (Barcelona), Fensterbau (Nuremberg), Interbuild (Birmingham), 100% Detail (London)



Since its set-up in 1919, the *Renson* company, a pioneer in natural ventilation, has consistently remained true to its mission: "to develop innovative concepts and products improving the indoor comfort, climate, air quality and overall living environment within buildings, whilst minimising energy demand".

With branches in France and the UK and a sales presence across Europe and beyond, *Renson* has secured European market leadership in its area of expertise, ventilation and solar shading solutions, and is widely considered the industry's standard. Its dynamic R&D department closely cooperates with authoritative European building research institutes, which consistently results in the development of a host of innovative systems and exciting new product launches in the area of sustainable building design and controls.

Its systems are in line with changing market trends and with ever more stringent building regulations and energy efficiency guidelines (like the Belgian EPB Energy Performance and Indoor Climate Regulation, setting a minimum energy efficiency standard for new and refurbished dwellings as from January 2006).

Apart from their proven functionality, *Renson* products and systems are also highly valued as an architectural design element in their own right and have been specified in numerous high-visibility architectural reference projects, both at home and abroad.

Its well-structured, multilingual website offers a host of product literature, technical system reports, detailing and designer aids, multi-purpose calculation tools...



New build and refurbishment schemes: domestic, residential, commercial, office environments...



RENSON

IZ 2 Vijverdam Maalbeekstraat 10 | B- 8790 WAREGEM

T +32 56 62 71 11 | F +32 56 60 28 51 |

info@renson.be | www.renson.eu

REYNAERS ALUMINIUM



Architectural aluminium solutions

Design, development, manufacturing and marketing of a broad range of architectural aluminium systems.

The portfolio can be broken down in the following product groups:

WINDOWS and DOORS

Central to this line is the Concept System® series, a unique modular system for aluminium joinery, consisting of a large choice of 2 and 3-chamber profiles, fully interchangeable and allowing easy assembly and various frame-vent combinations.

The range comes in various security classifications (burglar, fire, bullet proof), insulation features (with the CS 86 HI profile, featuring a Uf value of just 1.47 !), colours and styles (Functional, Renaissance, Softline or Hidden Vent or even a combined aluminium-wood window profile), allowing them to blend in to any architectural setting and providing an aluminium alternative to steel-framed glazing.

SLIDING SYSTEMS

Wide variety of high-performance sliding systems (fitted with sliding or "lift and slide" mechanisms on mono-, twin or triple track rails), available in a host of colours, designs, styles, insulation levels, dimensions (up to a staggering 6m width by 3m height)..., each system allowing optimum light incidence and creating an additional sense of space.

CURTAIN WALLING

Total façade and roof solutions designed for maximum daylighting in sloping vertical or curved glazing constructions.

The system accommodates all types of Reynaers doors, sliding systems and windows (hidden vent, turn-and-tilt, horizontal pivot) and other infills elements (in-plane photovoltaic panels, sandwich panels, vents...)

It also allows for various glazing alternatives: stick system, structural clamped, structural glazed, horizontal lining, cassette glazing or fully "unitised", pre-assembled systems for easy on-site mounting of large expanses of external (curtain) walling.



Variants available: fire proof profiles, (high-) insulated systems, slim line (with slender inner and outer sight lines), roof application units, aluminium-on-steel substructure sections...

Due to its slim sight lines - both to the inward and outward side - Reynaers' curtain walling can be detailed to any architect's brief for high-profile contemporary projects.

REYNAERS ALUMINIUM



CONSERVATORIES

Extensive range of insulated or non-insulated conservatory roof profiles (suited also for the construction of awnings and canopies).

The range of interior profiled sections comes in various individual styles (sleek Functional, Victorian-style Orangerie or the traditional Renaissance series). It also includes an extensive range of matching accessories (ventilation grilles, shading and screening, guttering, controls...) and can be combined with the entire Reynaers range of window, door and sliding systems.



Adjustable sunscreening with walkway

SUNSCREENING

Complete range of external solar shading solutions and architectural louvre systems with fixed or adjustable louvres, walkway shading applications..., preventing solar glare and overheating in glass-fronted and curtain-walled buildings.

PERIPHERAL SYSTEMS: *Cintro* profiles for arched spans, barrel vault rooflights or atrium glazing, ready to receive various types of glazing: laminated glass, polycarbonate, acrylic... Complementary range of railing and balustrade systems (open-front or glass-fronted), mounted insect screen systems, built-up and fully-glazed partitioning units (for patios, balconies, office partitioning...), swing entrance doors and shop front systems...

All Reynaers systems hold documented and authoritative technical approvals and test certifications, in accordance with the most stringent standards governing air and water tightness, wind loads, acoustic performance, thermal insulation, burglar resistance and other security-related issues. The company also provides for project-specific performance-testing (e.g. seismic testing for earthquake resistance)

The Reynaers range is available in over 400 quality colours and various finishes (gloss, matt-lacquered, anodised, scratch-resistant and low-maintenance Coatex® structure-lacquered, wood grain effect...), with various opening mechanisms, accessories and fittings...

More... Reynaers Aluminium has broadened its range of activities to other construction- and metalworking areas through a number of its partner companies: insulation of aluminium systems (Erap company), aluminium and



Cintro profiles for barrel vault rooflights

REYNAERS ALUMINIUM

stainless steel building products (Roval company), aluminium components, aluminium coating and surface treatment (Alural company)



Some of Reynaers' most successful branded ranges:
windows and doors: *Eco System* and *Concept System* (CS);
sliding systems: *Concept Patio* or *Thermo Patio*;
curtain walling: *CW 50* and *CW 60*
conservatories : *CR 120*, *PR 200*, *TR 200*
sunscreening: *BS 100/30/20*;
peripherals: *Cintro*, *Mosquito*, *RB 10*



Worldwide exports to over 55 countries, with branch offices in 26 countries (Austria, Bulgaria, China, Czech Republic, Slovakia, France, Germany, Hungary, India, Ireland, Italy, Latvia, Lithuania, Bahrain, the Netherlands, Poland, La Réunion, Romania, Russia, Slovenia, Spain, Sweden, Switzerland, Turkey, Ukraine, UK)



Priority markets targeted are the Middle East and Asia



Architects, specifiers, consulting engineers, contractors, project developers, real estate investment companies, professional aluminium fabricators and construction firms (windows, doors, façades, cladding)



All major international construction fairs throughout Europe: Bau (München), Internationale Bouwbeurs (Utrecht), Construmat (Barcelona), Batimat (Paris), Veteco (Madrid), GulfBid (Bahrain), Mosbuild (Moscow), Primus specialized building fairs (Kiev), Polyclose (Ghent)...



Reynaers Aluminium, established in 1965 and headquartered in Duffel (Belgium), features prominently among the top 5 premium European brands in high-quality architectural aluminium systems.

The company has an impressive track record indeed. Personnel levels and global sales to some 60 countries have increased 10-fold in the last 2 decades. Worldwide exports now account for ¾ of total turnover, which earned the company a nomination for the Flanders Lion of the Export Award in 2004, the very same year its current CEO, Ms. Martine Reynaers, was awarded the Manager of the Year Award.

Reynaers' leading position overseas is largely owed to its ability to adapt its business model and supply chain management to local market conditions on priority (target) markets, to act as a local player and the company's dynamic R&D and innovation drive.

The innovation effort primarily centres on the design, engineering and development of market-specific and non-standard architectural project solutions, improving the overall quality of its systems portfolio.

Some of key innovation issues the company addresses are: improved thermal and energy efficiency, security, acoustic performance levels, ease of on-site installation... (unitisation, off-site construction methods for structural aluminium modules...), enhanced aesthetic appeal, maximizing creative design freedom and infinite architectural expression...

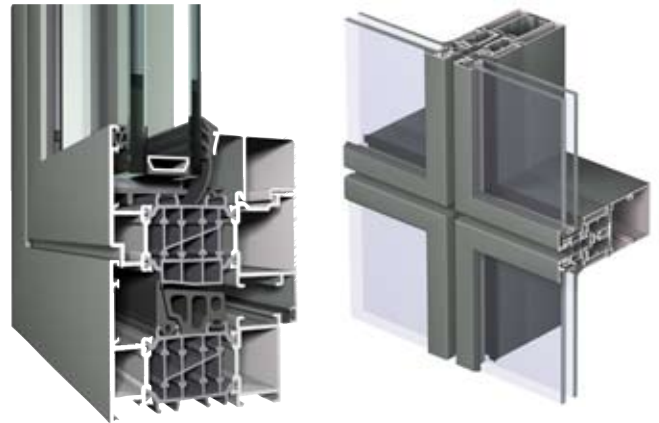

CS86-HI high-insulation profile CW 86-EF cassette glazing curtain walling



Doha Sport City Tower (Qatar)

REYNAERS ALUMINIUM

At the heart of the company's innovation strategy is the **Reynaers Institute** which acts as:

- an international knowledge and research centre, hosting test facilities for rigorous compliance-, performance- testing of all Reynaers systems developed (in the mock-up or prototype stages of development);

- a venue for basic and specialist training courses in processing, assembly, building techniques..., for product launches, demonstrations of up-to-the minute technologies, automated processing station equipment...;

- a meeting point and communication platform for all those involved in the aluminium construction process (suppliers, architects, specifiers, fabricators, contractors...).

In an attempt to bridge the gap between architectural education, the construction industry and the international architectural business scene, Reynaers Aluminium teamed up with all major Belgian Schools of Architecture and the globally renowned London-based architectural office Foster & Partners and launched the Reynaers Institute Award scheme in 2002 for aspiring architects.

Reynaers Aluminium provides its fabricator and contractor customers with a comprehensive support package, including technical and commercial training, tooling and equipment guidance, on-site assistance and an impressive range of dedicated proprietary software (drawing, calculation and tendering software, design and detailing tools, automated order lists, sunscreening parameter monitoring...)

Sustainable development policy: through research, innovation and product development, the company considerably contributes to a more sustainable architecture:

- by marketing innovative products with enhanced thermal performance properties, double-skin façade solutions and suncreening systems, improving a building's energy management, (passive) solar gain, comfort and indoor climate;
- by monitoring sustainable manufacturing and storage (e.g. by installing Belgium's largest 16,000 m² solar roof system on top of its latest warehouse extension, supplying up to 500,000 kWh of solar produced electricity a year), eco-friendly packaging and distribution processes (re-use of packing materials, no CFC or any other hazardous substance used in profile insulants, decentralised stock management and local marketing, thus reducing transport movements);
- by product development suited for improving a building's accessibility and comfort for disabled people;
- by fostering recycling and reprocessing of scrap aluminium as a secondary raw material;
- by effective talent management of its multi-ethnic workforce through training, coaching and competence development.

The company's 8-language website provides home-owners, fabricators, contractors, architects, specifiers... with invaluable technical information on all systems, on a host of successfully completed international projects, Reynaers solutions have been used on...



New build and renovation projects on both the private residential market and the project market (utilities, office and apartment buildings, hotels, shopping centres, department stores, public utilities and public access buildings, schools, hospitals...)



Test centre at the Reynaers Institute

REYNAERS ALUMINIUM

Oude Liersebaan 266 | 2570 DUFFEL

T +32 15 30 85 00 | F +32 15 30 86 00

info@reynaers.com | w ww.reynaers.com

ROLVAPLAST



Decorative wall and ceiling panels from UPVC: printed or coated

In line with its motto 'Rolvaplast – the panelling solution' this manufacturer offers an extensive choice of decorative claddings and matching finishing profiles:

- A great variety of regularly updated designs for both printed and coated panels, including woodgrain patterns, marbled effects, high-gloss panels, mosaic patterns... in a truly wide choice of colours. *Rolvaplast's* array of products includes a number of bevelled edged boards (including V-grooved three-panel sections).
- Depending on the type of claddings chosen, several sizes are available. Widths available are: 10 cm, 16.7 cm, 25 cm (predominantly) and 33.3 cm. Lengths available include: 2.6 m, 2.7 m, 4.5 m, 6 m and 7 m.

Rolvaplast's cladding panels can be fitted using nails, staples or glue. Noteworthy in this respect is the in-house engineered *duo-clic* system applied for some ranges.

All panels are suitable for 'wet room' use. Further features (applicable to some ranges) are: fire resistance rating class M1, anti-bacterial and/or insect repellent properties and lead-free composition.

More... *Rolvaplast* also manufactures UPVC window sills, decorative shutters, roll-down shutters, sidings and gutter cladding, as well as WPC (wood-thermoplastic composite) sidings and profiles for various uses.



Batimat (Paris), Interbuild (Birmingham), Swiss Bau (Basel)



Since its start-up in 1967 this family-owned company (with short communication and decision-making channels) has become a major European manufacturer of UPVC sections for the building industry and for DIY enthusiasts.

Some 80% of its turnover is export earned, with markets situated predominantly (but not exclusively) within Europe.

Rolvaplast has not only highly automated extrusion and coating lines, but also boasts its own R&D department (hence the patented *duo-clic* system).

Rolvaplast offers from stock a very diverse portfolio (in terms of colours, designs and sizes) of affordable quality panels. Tailored production for client specific needs is a definite possibility.

Although flexible in terms of design and manufacturing, *Rolvaplast* maintains strict delivery schedules. Product literature is available in various languages.



Residential market



ROLVAPLAST

Pelsestraat 1 | B - 9800 DEINZE
T +32 51 63 39 45 | F +32 51 63 56 82
info@rolvaplast.be | www.rolvaplast.be



Smoke control and fire compartmentation devices...

... inhibiting the spread of smoke, excessive heat or fire throughout a building, by automatically isolating areas of fire in HVAC ducting systems.



Rf-Technologies' vast passive fire protection range includes:

- fire dampers which, depending on their application, are suited for vertical or horizontal mounting in ceilings or walls, made of different structural materials (concrete, masonry, drywall partitioning), available in various dimensions, shutter types, rectangular or circular, with varying fire resistance ratings up to 240 min.), catering for various air flow rates (including high pressure...) and fitted with a variety of operation and control mechanisms (fusible-link-activated thermal release, remote-controlled, combined systems...);
- smoke control/extraction dampers and shutters against smoke leakage and propagation;



CW60 fire damper mounted in drywall partitioning

- fire-resistant valves, intumescent fire grilles and ventilation louvres to be fitted into fire-resistant walls and doorsets, providing up to 120 min. fire resistance;
- fire-stopping collars for piping, ducting, tubing, conduits and other service penetrations in compartment walls, floors and ceilings...;
- heat-resistant, fire-stopping, sealing and jointing materials (plasters, mortars, sealants, adhesives, insulating foams, strips, sleeves, fire stop pillows, fire-resistant building boards, built-up service and access hatches...).



Rf-Technologies



Belgium, the Netherlands, Luxembourg, France, Norway, Italy, Portugal, Bulgaria, Spain, Sweden, Rumania, Bulgaria, Finland



Germany, Poland, Slovakia, Slovenia, Russia



Distributors, architects, specialist fire protection specifiers, consulting engineers

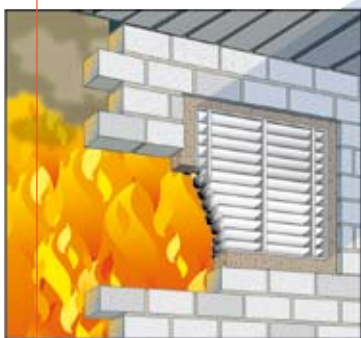
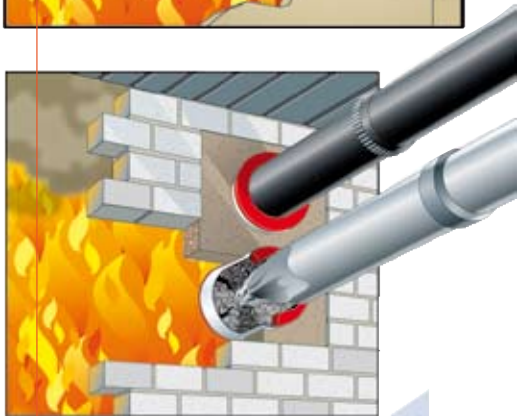
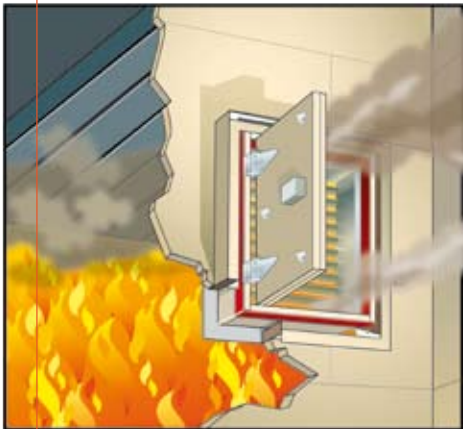

Mostra Convegno Expocomfort (Milan):
bi-annual participation



Since it was set up in 1985, Rf-Technologies (RFT) has definitely come of age in its core area of expertise: the design, development, engineering and marketing of high-performance systems for fire compartmentation and smoke control.

RFT has pursued a consistent policy of research and innovative product development (it was the first to introduce circular fire dampers) and worked its way into the highest echelons of the European passive fire protection industry.

Quality control and innovation:

RFT has an ISO 9001-2000 certified quality monitoring system in place. Both its in-house lab and various internationally accredited testing facilities have rigorously tested the entire product range, according to European CPD standards, governing fire resistance performance of "ducts, dampers, shutters..." (EN 13501-3, EN 1366...)

Moreover, its fire protection systems are backed up by a host of "glowing" assessment reports and performance approvals from authoritative international certifying bodies (e.g. Swedish SITAC, French NF).

Outstanding service record to customers: extensive technical support on and off-site, comprehensive product literature, professional design and installation guidance, aerodynamic calculation aid, quality screening, system upgrades throughout the lifetime of each individual fire safety project...

A member company of the Agoria Fire Technologies cluster of leading Belgian companies, involved in active and passive fire protection, RFT won the 2006 Trends Gazelle Award for outstanding regional business growth and competitive SME entrepreneurship.



Project market (public access buildings, office towers and high-rise building projects as a whole)

Rf-TECHNOLOGIES

Lange Ambachtenstraat 40 | B - 9860 OOSTERZELE
T +32 9 363 90 66 | F +32 9 362 33 07
info@rft.be | www.rft.be

SADEF



Pre-engineered steel building components (profiles, frames and entire building systems) for fast-track construction of residential and industrial steel buildings



Sadef



The whole of Europe



Middle East



Construction and engineering companies



Bau (Munich), Metapro (Brussels), Esef and Internationale Bouwbeurs (Utrecht), Tube (Düsseldorf), Construlan (Bilbao), Tektonika (Lisbon), Z (Leipzig), Euroblech (Hannover), Concreta (Porto), Big 5 (Dubai), Midest (Paris), Elmia (Jonköping), Metalexpo (Paris), Instrutec (Tallinn), Industrie- en Projectbouw (Antwerp)



Part of the leading Austrian steel-processing group *Voest Alpine*, Sadef boasts 60 years' expertise in design and manufacture of roll-formed steel sections.

Over the years, the company increasingly broadened its product range to include modular building components for fast-track structural steelwork (roofs, walls, floors), including cold-rolled sections (SIGMA, SIGMAplus, ZED, CEE (plus), SE-eaves beam and a standard range of assorted auxiliary products;

Exciting alternative to traditional construction materials and proven export potential: pre-engineered, modular, lightweight, swift delivery to site, easy assembly, even by moderately skilled personnel, material and operating cost savings, dismantlable and re-usable building components, highly-resistant to earthquakes and hurricane-scale winds, compact packaging, quick-time site erection plans supplied, use of local materials an option;

SADEF



SADEF

Stringent quality control: high-grade, hot-dipped galvanized steel sheet, certification and endorsement reports: ISO 9002, SOCOTEC (F), Ü-Zeichen (D), B certificate (PL), vast engineering know-how, in-house design team, state-of-the art machining, broad variety of surface finishes (zinc phosphated, e-coated, powder-coated), range of ancillary products (cleats, anti-sag bars...), some of it patented, like the flooring profile connection lugs);

Full project-related and customer-oriented support services package offered: early-stage project involvement and comprehensive engineering assistance from in-house engineering and development department, web-based 3D-CAD steelwork detailing, order specification and calculation tools available for all parties professionally involved in the project (architect, specifier, engineering firm, contractor);

Industrial / commercial and residential projects (emergency) housing, new build, refurbishments, storey extensions...]



SADEF

Bruggesteinweg 60 | B - 8830 GITS
T +32 51 26 13 94 | F +32 51 26 13 01
sales@sadef.be | www.sadef.be



SOPREMA



Bituminous waterproofing sheeting and other liquid-applied damp and waterproofing products

Broad-range of high-performance elastomeric (SBS and APP modified) bitumen waterproofing membranes with a composite polyester and/or glass-fibre-reinforcement, base sheets and vapour barriers.

for new-build, refurbishment reroofing or structural waterproofing of civil engineering structures or other specialist applications like root-inhibiting membranes for prevegetated green roofs.



Primary applications are in single-ply, multi-layer and fully built-up roofing schemes on various types of substrate (concrete, steel, timber...).

The range of membranes, some of which are available in a number of finishes slate or granule-coated, aluminium or copper-faced), allows for various application methods: torch-on, heat-welding, no-flame adhesive application, mechanical fixation or by *Macaden* automated installation (for waterproofing large roof areas, bridge decks, parking lots...)

The comprehensive range of membranes are further supplemented by an auxiliary array of primers, sealants, mastics, cold bonding adhesives, liquid waterproofing products, protective coatings..., all suited to the entire range of high-performance waterproofing solutions by Soprema.

Featuring among the successful product innovations are Flashing, a liquid-applied reinforced PUR resin-bitumen seamless waterproofing product, one-time winner of the Batimat gold medal for product innovation, the Paruvel solar reflective acrylic coating, Alsan Quick 500 balcony waterproofing, the Alsan 410 solvent-free waterproofing resin for indoor use... and many more.



SBS-modified range: *Sopralene (Optima, Techno, Monoflex, Techno Venti, Monoflex Venti, Stick C 40, Garden, Venti Stick C 40...)*; **APP-modified range:** *Sopragum (Optima, Techno, Garden...)*; **Vapour barriers:** *Sopravap (Alu 3, Alu Activa 1, Stick Alu TS, Stick A 15, C 15...)*; **Liquid PUR-elastomeric bitumen:** *Alsan Flashing...*



Scandinavia, Ireland



Ongoing market development and further consolidation of existing markets



Importers and distributors of building chemicals and waterproofing systems, roofing contractors, builders' merchants, architects and consulting engineers



No trade fair participation as yet, but frequent sales presence by partner companies at major international construction fairs

SOPREMA



Prevegetated green roof build-up by Soprema

Part of the French international SOPREMA group of companies, a world leader in the development and manufacture of class leading waterproofing products, with an annual production of 100 million m² of waterproofing membranes.

Most products in the Soprema range bear comprehensive technical agreement, approval and certification by a host of independent national and international test facilities and authoritative certification institutes, both across the EU and the US: CE (EU Building Products Directive), ATG-BENOR, BBA, BDA-KOMO, CSTB, FM, ASTM, ZUS, FMPA, FLL and DIN, BYGGFORSK, COBR and IBDiM, AENOR and MINER, Documento de Homologação (PT), AR, SKTC, SITAC, EMPA...

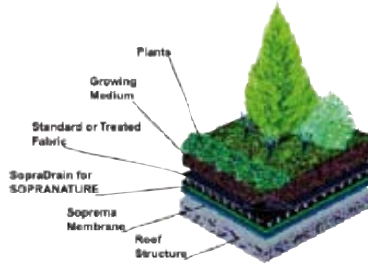

Soprema boasts preferred supplier status of high-performance waterproofing systems with some of the most exacting customers (owners, architects, specifiers...) on a host of prestigious high-profile buildings of varying architectural or engineering design, like the Strasbourg European Parliament Building, the London Jubilee Library, Shanghai Auchan Shopping Centre, Monaco Convention Centre, New York George Washington Bridge, Florida Island Adventure Theme Park, Hong Kong Science and Technology University, AVE high-speed railway viaduct (Spain), Singapore Grand Hotel Fullerton... to mention but a few.



Construction, civil engineering and environmental protection applications in industrial, commercial, institutional and residential projects



New York George Washington Bridge



San Francisco Int'l Airport expansion



Strasbourg EU Parliament

Singapore Fullerton Hotel



SOPREMA

Bouwvelven 5 | B - 2280 GROBBENDONK
 T +32 14 23 07 07 | F +32 14 23 07 77
 info@soprema.be | www.soprema.be



Specialty construction chemicals: sealants, adhesives and polyurethane foams

One of the very first manufacturers of PUR foams in Europe, *Soudal* now boasts quite an “expanding” portfolio of such foams on the international market, including gun and adaptor foams, 1 and 2-component and specialty graded foams (fire-rated, low-expansion, isocyanate-free...)

For many decades now, *Soudal* has also been setting the standard for professional sealing and bonding, with an unparalleled range of sealants and adhesives of varying composition (silicone, MS-polymer, PU, elastomeric, neoprene, acrylic, polybutylene, bituminous...) and suited for a variety of applications: roofing, waterproofing, weathersealing, structural glazing, flooring, sanitary fittings, decoration and finishing, car body repair work or in demanding fire-class or food-grade applications...

Its range also includes specialist accessories and complementary products like applicator tools, primers, cleaning agents, joint sealant and weathersealing tapes and strips...

The *Soudal* range is specifically designed to meet the needs of the most exacting customers in the building trade, the DIY retail sector and other branches of industry (transportation, automotive...)

Multiple product endorsement:
The fully ISO 9001 certified quality monitoring system the company has in place, vouches for the consistent premium quality of its product range, backed by independent third-party certification from both national and international testing and research authorities (ATG, KOMO, CSI, IFT, DIN 4102-B2, MTK, MPA, IVD...)

Corporate brand: *Soudal*®;
Product and system brands: *Silirub*®, *Soudaseal*®, *Soudafoam*®, *Fix-all*®, *Click & Fix*®

Worldwide exports to over 100 countries

Continuing worldwide marketing effort

Distributors, agents, wholesale builders' merchant trade, DIY chains, architects and



SOUDAL



Batibouw (Brussels), Batimat (Paris), Bau (Munich), Internationale Bouwbeurs (Utrecht), Building Fair (Zagreb), Construma (Budapest), Construmat (Barcelona), DIY (Courtrai- Belgium), Europarket (Maastricht), Polyclose (Ghent), Interbuild (Birmingham), Maja I (Riga), Mosbuild (Moscow), Practical World (Cologne), Turkeybuild (Turkey), Veteco (Madrid)



With over 40 years of pioneering experience in the trade, the *Soudal* company has over the decades developed into Europe's largest independent manufacturer of sealants, adhesives and polyurethane foams. It currently exports about 90% of its total output to over 100 countries across the globe.



Relying on extensive know-how on advanced bonding and sealing technologies, 3 fully-automated, state-of-the-art manufacturing sites in Turnhout (B), Leverkusen (D) and Ayrton (F) and supported by a dynamic sales presence in over 24 countries, the company is able to guarantee its global customers flexible batch-processing, fully-customized delivery options and market-specific merchandising.

No wonder that *Soudal* is an established household brand on DIY store shelves and a trusted supplier of specialist building chemicals to building contractors and other industrial customers worldwide

The company is strongly committed to R&D and innovative product development, resulting in frequent launches of "improved formulation" products (e.g. the first manufacturer-recommended sealant for self-cleaning glass, new user-friendly applicator tools (e.g. the patented *Click and Fix*® gun foam applicator or the gun-less *Fix all PressPack*), retail packaging make-overs for enhanced brand positioning...

Soudal's environmental concern has been clearly evidenced by its pioneering development and marketing of ecologically-sound building chemicals in line with the most stringent environmental standards (CFC-free products, isocyanate-free PUR foam...) or in fostering PUR and aerosol recycling schemes: PDR (D) and RECYPUR (NL).

Well laid-out and highly-informative multilingual (12-language !) website



Professional construction, consumer/DIY and industrial markets



SOUDAL

Everdongenlaan 18-20 | B - 2300 TURNHOUT
T +32 14 42 42 31 | F +32 14 42 65 14
info@soudal.com | www.soudal.com

Vitrified clay (VC) pipes and fittings for sewerage and drainage systems

Spigot/socket-jointed pipes for traditional open trench pipe-laying; Additional range of **fittings** (both VC and non-clay): tapered and adaptor pipes, bends, junctions (for laterals and off-takes), saddles, end caps flexible couplings, seals and (shrink) sleeves, connecting sockets...

Jacking pipes for trenchless installation of non-man entry size sewerage or drainage pipework and microtunnelling, involving minimal surface disruption. The range also includes composite jacking pipes, made up of an outer concrete pipe with an inner lining, consisting of either a VC pipe or *KeraLine*® tiling.

Inliner pipes for relining work on existing pipelines;

KeraLine® prefab lining sheets and **shells** made up of epoxy-bonded VC ceramic tiles for rehabilitating, redeveloping and relining deteriorated sewers, sump pits, catch basins, pump wells, tunnel linings and pipe beds.

Manholes, inspection and flushing chambers, channelling units, road and stormwater drainage gullies, discharge culverts, perforated drainage pipes...

More... auxiliary accessories and tools for cutting, laying, testing... VC pipework

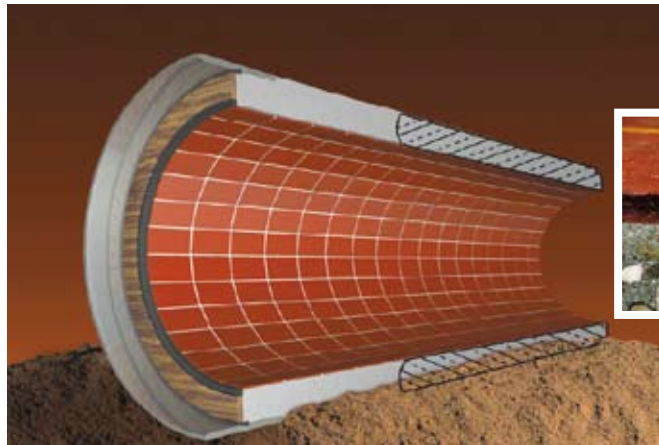

Steinzeug | Keramo



Europe as a whole, with Benelux, France, Germany, Poland, Czech Republic as priority markets; Other key markets include Australia and New Zealand, Egypt, the Middle East (Yemen, Saudi Arabia, Iran), Asia (Vietnam, Sri Lanka, Malaysia, Taiwan, Hong Kong, Singapore, Brunei

Bulgaria, Rumania, Hungary, Russia, China and Japan

STEINZEUG | KERAMO



Public environmental authorities, utility companies, wastewater services companies, leading contractors and engineering companies, consulting engineers, local marketing agents



No set schedule for trade fair participation, as attendance may vary according to ongoing marketing priorities. Regular sales presence at BAU and IFAT (Munich), Budma (Poznan), Trenchless Asia (Shanghai) and Middle East (Dubai)...



With roots going back as far as 1957, the *Steinzeug | Keramo* company has become an established household name as a globally trusted supplier of high-performance vitrified clay pipe materials for the construction, renovation and rehabilitation of drainage and sewerage pipelines. Over 90% of output generated by the company's 3 production sites - 2 in Germany and 1 in Belgium - is earmarked for worldwide export.

Vitrified clay has a number of unparalleled properties and intrinsic benefits over alternative pipe materials: it is an environmentally-sound and fully recyclable material, providing high-strength and durability, a prolonged service life, resistance to chemical attack and to high-pressure mechanical cleaning...



A policy of constant research and product development has led *Steinzeug | Keramo* to launch a host of innovative VC products, like longer-length and lower-weight pipes, inspection and flushing chambers, highly flexible joints and an unparalleled range of high-specification VC jacking pipes for trenchless installation...

The entire range of standard and customised VC pipes and accessories fully complies with - and often surpasses - the stringent requirements of EN 295, the EU regulation governing vitrified clay pipe materials and accessories. By the way, Keramo Steinzeug chaired the committee tasked with drafting the original EN 295 guideline.



Extensive range of services provided, from technical product specification support, drainage and sewerage design and lay-out assistance, comprehensive engineering advice, both off and on-site, hydrodynamic modelling tools...



Project market only (civil and hydraulic engineering)

KERAMO STEINZEUG N.V.

Paalsteenstraat 36 | B-3500 HASSELT

T +32 11 21 02 32 | F +32 11 21 09 44

info@keramo-steinzeug.be | www.steinzeug-keramo.com



1. Fibre cement (FC) products

• FC corrugated sheets

The SVK *Neptunus*[®] range of corrugated sheets has a number of definite advantageous properties: it is sturdy and durable, lightweight, vapour permeable, entirely waterproof, corrosion and fire-resistant. It also comes with an extensive array of fittings and accessories like ridges, eaves, closure pieces, flashings, bend sheets, barge boards, (ventilated) cranked crown sheets...

This 6-corrugations range is available in 8 colourfast finishes, anti-fungal coated, in lengths ranging from 1.25 up to 2.50 m. The sheets also have reinforcement strips, pre-cut mitring outlines and an anti-skid grid-like surface structure. The range fully complies with all technical and safety requirements for corrugated sheets (EN 494, BENOR, KOMO, NF, CSTB, BG-Prufzert, DIBT, DLG).

• FC slates for roofing and wall cladding

The *Montana*[®], *Ardonit*[®] and *Fasonit*[®] range encompasses a broad line of FC roofing and cladding slates, closely replicating the appearance of natural slate, with the additional advantage of being lightweight, durable, easy and economical to handle/install, preholed, available in as many as 8 different sizes and up to 6 colour shades (for some series). 5 shapes are on offer (rectangular, square and large-size square, beavers' tail with cut corners, diamond-shaped) and various surface (smooth or textured) and edge finishes (square or dressed edge).

A comprehensive range of fittings and accessories (ridges, vent systems...) complements the slates in full compliance with EN 492 product specifications for FC slates and fittings.

• *Ornimat*[®] FC cladding boards

This range of high-durability cladding for outdoor and indoor use is available in a choice of 20 standard matt enamel surface finish colours (with over 60 factory-approved RAL colours available on request...). The exclusive *Ornimat Design*[®] line comes in 6 colours with a metallic gloss finish. Size range: to customer specification (up to 3070 x 1220 mm)

• *Novex*[®] vapour permeable FC roof underlay

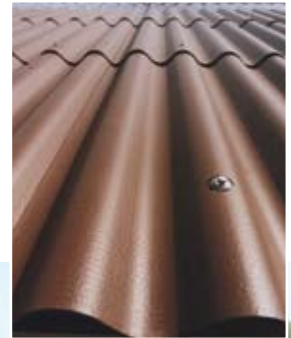

2. Fired clay products

- *Artisan*[®] range of 15 types of moulded facing bricks, each with their own characteristic colour shade, naturally textured surface and size range (some series can be had in as many as 5 different brick sizes, including brick slips);

- *Classico*[®] extruded wire-cut hollow bricks for structural masonry work;



3. Precast concrete products

- *Titan*® paving slabs with a reconstructed stone effect in various surface finishes (polished, blasted)
- *Gigant*® fair-faced concrete elements, custom-made in purpose-built moulds. Included in the range are cladding panels, precast balcony units, door and window sills, architectural ornaments (pediments, cornices...), all available in a broad range of high-quality factory finishes (exposed aggregate, polished, acidified, brick-faced or tile-clad, with two-sided finishes...)

More... licensed distributor of various building materials (clay pavers, roofing tiles, cavity wall insulation boards, drywall plasterboard panels, glass blocks, oil storage tanks)



SVK *Neptunus, Montana, Ardonit, Fasonit, Ornimat, Novex, Artisan, Classico, Titan, Gigant*



France, The Netherlands, Germany, UK, Ireland, Luxemburg, Denmark, Switzerland



Global marketing effort ongoing with particular emphasis on Japan (for the brick range) and the Scandinavian countries and new EU member states (Czech Republic, Estonia, Cyprus, Latvia, Lithuania, Hungary, Malta, Poland, Slovakia and Slovenia (for both the brick and fibre cement materials ranges)



Market approach may vary according to market targeted: Importers, builders' merchants, large building or roofing contractors, ... insofar as they cover a certain sales area and are able to stock full loads



Batibouw (Brussels), Nordbat (Lille), Innovatiegala Architect (Rotterdam), Green Expo (Ghent-Belgium)
Participation to other construction-related trade fairs is under consideration



Originally set up in 1905 as a small-scale brick works to become a pioneering manufacturer of fibre-cement products in 1923, SVK has over the years expanded and diversified its activities and developed into a leading European supplier of a broad spectrum of building materials with an unrivalled portfolio of fibre cement, fired clay and precast concrete products.

Backed by unparalleled know-how and workmanship, a century of manufacturing experience, cutting-edge manufacturing technology, an unrelenting quality control policy and comprehensive product quality certification from various independent international certifying bodies, a second-to-none service delivery record and an unparalleled warranty coverage, SVK has had its quality products widely specified for numerous prestigious international new-build or refurbishment projects.



Agricultural, industrial, public construction projects and residential housing development schemes



SVK

Aerschotstraat 114 | B - 9100 SINT-NIKLAAS

T +32 3 760 49 00 | F +32 3 777 47 84

info@svk.be | www.svk.be



Specialist technical building products for...

- **... preventive structural waterproofing:** expandable bentonite rubber swelling seals, waterstop joint ribbons, sealants and injection hoses for water-proofing of concrete construction joints

- **... remedial structural waterproofing:** PU and Acrylic-based injection resins (for injecting leaking cracks, fissures, voids... in concrete, soil stabilization), water-proofing against rising damp in masonry, crystalline concrete waterproofing grouts and admixtures, water-repellent coatings, ancillary equipment (dispensing systems, pumps, applicators)

- **... (patented) external CFRP reinforcement systems** for building structures (concrete, wood, masonry): uni- and multi-directional (boltable) carbon-fibre reinforced polymers (CFRP), technical textiles and composites, aramid fibres, resin-based coatings, adhesives, polymer-modified cementitious repair and patching mortars, fillers, epoxy injection resins...

- **Chemical-resistant industrial flooring** (PU-, epoxy- and vinylester-based, polyurea)

- **Geosynthetic leak-sealing membranes and waterproofing barriers** (reinforced geomembranes, containment bunds for transformers...)

- **Joint filler** fast-curing



PC® Bentostrip (T, Salt), PC® Injectra, PC® Leakinject, PC® 509 Acryl, PC® Cristal, PC® Hydrosilan, PC® Puraea, PC® CarboComp® (Plus, Sandwich), Enviromat®, MRC® 1500...



Europe, Middle East and Far East



Ongoing worldwide marketing effort pursued



Distributors, engineering offices, architects, specifiers, contractors of structural waterproofing projects



Bau (Munich), Bitumendag (B, NL...), Matexpo (Courtrai-Belgium), Ifest and Infratech (Ghent- Belgium), Green Expo (Courtrai), Pro-Vert (Marche-en-Famenne)



TRADECC



Set up in 1989, Tradecc arose from the Belgian ECC group of companies, steeped in about half a century of significant knowledge and specialist manufacturing and engineering expertise in technical building chemicals for structural waterproofing, surface coatings, external reinforcement and repair of industrial, building and environmental structures.

Tradecc's integrated approach, encompasses all business stages from research, design and development, manufacturing, engineering consultancy, contracting, through to sales and distribution.

This dynamic company policy has won Tradecc's broad international customer approval of its highly innovative and solutions-led range of high-tech building products.

The company currently operates a sales office in Bangkok and a Cairo rep office.

The company's innovative product range has been:

- extensively site-tested and expertly applied by its associated companies;
- documented by various test facilities and authoritatively certified by national and international accreditation bodies;
- holds a number of application-specific approvals (potable water approval, UK WRAS approval, compliance with VLAREM Flemish, environmental permit laws...);
- specified on notoriously demanding industrial, environmental and construction engineering projects.



Mainly project market applications in the chemical, industrial, environmental and construction industries (road building, hydraulic and civil engineering, marine construction, sewage treatment...)



TRADECC

Terbekehofdreef 50-52 | B - 2610 WILRIJK
T +32 3 828 94 95 | F +32 3 830 27 69
info@tradecc.be | www.tradecc .be



High-grade engineered wood products and sheet materi-

...for light-side interior outfitting and panelling applications:

- Post-formed laminate products for worktops, window sills, frames, desks, radiator covers...;
- 3-dimensional foiled furniture fronts and accessories;
- Sound-absorbing acoustic panels (e.g. for wall panelling, fixed and movable partitioning applications...);
- Sandwich panels with various core materials for indoor and outdoor uses (filling panels, partitioning, exhibition stand building, mobile home interiors...).

More... *Triplaco* is a member of *Lefevere Industries*, a vertically integrated group of companies, operating internationally and involved in manufacturing and marketing activities as wide-ranging as timber trading for the carpentry and joinery industry, audio and video furniture, loudspeaker cabinets through to thermoplastic parts for the automotive, audio, video and various other industries



Triplaco

France, the Netherlands, Germany, UK, Denmark, Japan, Czech Republic, Slovakia, the Baltic States, Hungary, Ukraine, Russia

France, the Netherlands, Russia, CEE countries...

Window manufacturers and professional builders' merchants

Interieur Bouw (Gorinchem-NL), Glassex (Birmingham), Fensterbau/Frontale (Nuremberg, Moscow), Architect@Work (Courtrai-Belgium)...

Over half a century's experience in developing, manufacturing and marketing a broad array of high-quality engineered sheet materials and panelling solutions;

Continued innovative product development drive (e.g. the acoustic panel range) and customization, resulting in comprehensive subcontracting expertise for a great many industrial customers of international repute;

Operating top-notch manufacturing and processing plant to the highest international quality standards; Fully-owned production and distribution centre in the Czech Republic

Project, utility and contract markets, as well as smaller-scale residential market applications



TRIPLACO

Generaal Deprezstraat 21 B - 8530 HARELBEKE
 T +32 56 22 62 17 | F +32 22 98 15
info@triplaco.be | www.triplaco.be

TRISLOT



Decorative stainless steel grilles, gratings and screens...

...typically consisting of a range of parallel triangular (wedge-shaped) surface profile wires (available in 10 different varieties), perpendicularly welded in an automated process on to support profiles/rods made of various stainless steel alloys. Slot apertures between surface profiles range from as little as 0.1 up to 10 mm, with a maximum 4 mm slot width meeting pedestrian traffic heelproof standards.

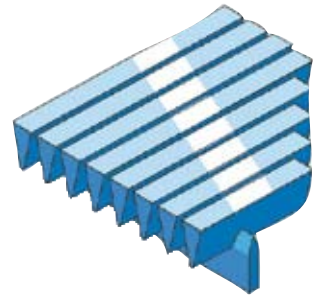

The supporting profiles/rods can be adapted to be self-supporting, depending on project-specific structural requirements (span, design loadings, required height...).

Derived from one of both basic shapes (flat or tubular/cylindrical), virtually any other shape or configuration can be manufactured to customer specification: flat screens, cylindrical screens, slot tubes or tubular grilles... in a variety of factory finishes: pickled and passivated (standard), bead-blasted, mechanically or electro-polished.



More... custom-made stainless steel elements for filtration and separation applications in the food and beverage, pharmaceutical, petrochemical, environmental... industries



Trislot® wedge grilles, *Lumicono* (outdoor lighting fixture)



Worldwide markets (serviced by the company's globally established sales force for its filtration and separation technology)



Worldwide marketing effort ongoing



Architect@Work (Courtrai-Belgium), Airport Build & Supply Exhibition and the Big 5 (Dubai), 100% Detail (London)



Architects, specifiers, consulting engineering firms specialising in major, high-profile projects (hotels, airports, public access buildings...)



 Trislot

TRISLOT



Trislot, once part of the Bekaert international steel wire company, has achieved global renown as a leading manufacturer of custom-made stainless steel elements for filtration and separation various industries.

Stainless steel features ever more prominently within contemporary architecture due to its outstanding structural characteristics and its sleek visual appeal.

Acting on this market trend, Trislot has successfully branched out into developing decorative stainless steel solutions for the high-profile architectural project market, which currently accounts for some 20% of the company's turnover.



The company's portfolio of bespoke architectural stainless steel features includes ventilation and airco grilles, stairway treads, pedestrian walkway gratings, banisters, handrails and balustrades, infill panels and partition walls, cladding, swimming pool or floor drain gratings, urban furniture, architectural lighting (e.g. the stylish *Lumicono*, a slender cone-shaped outdoor lighting column, *made by Trislot*) and a myriad of other architectural features, for both internal and outdoor use.

Trislot boasts proprietary state-of-the-art manufacturing and machining equipment (entirely in-house developed and purpose-built) and offers an outstanding quality of product and innovative designs to enhance the appeal of any architectural project.

The company allows architects and designers unconstrained creative freedom by pursuing a policy of comprehensive customisation, bespoke product development, a manufacturing service tailored to the most stringent project specifications, to the most rigorous site-measured dimensions or the customer's most challenging creative brief.

Trislot® decorative grilles, gratings and screens have met with approval from top-ranking international architects. These are just some high-profile international architectural projects on which *Trislot*® solutions have been specified: 'O' de Squisito houseboat (Dubai - airco grilles), Taj Hotel (Abu Dhabi - swimming pool gratings), Fairmount Hotel (Dubai - illuminated pillar cladding), Bodemuseum and Deutsches Historisches Museum (Berlin - ventilation grilles), Hotel Puerta America (Madrid - shower gratings), Amsterdam airport lounge (security fencing cover grilles), Museum of Islamic Art (Doha-Qatar), Charles de Gaulle airport S3 terminal (Paris), Heathrow Airport (London), European Court of Justice (Luxembourg)...



Given the high level of customization and the exclusive nature of its product portfolio, Trislot targets the highest end of the international project markets (residential, commercial and public)

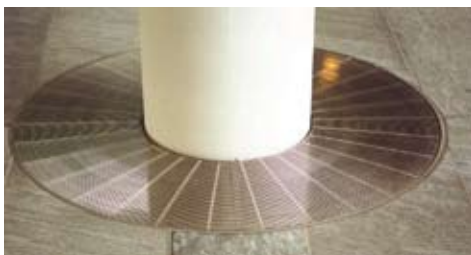
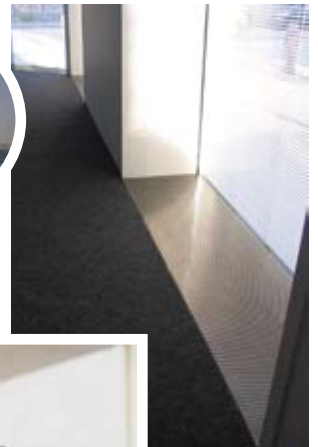

TRISLOT nv

Roterijstraat 134 | 8790 WAREGEM

T +32 56 62 72 22 | F +32 56 62 72 62

info@trislot.be | www.trislot.be | www.trislot-deco.com

URBASTYLE



Precast architectural concrete elements for civil engineering and road-building applications:...

... urban street furniture for external public spaces, bollards, planters, retaining walls, cycle racks, tree protection grids, benches and seating, road humps, hard landscaping items (pavers, tiles and slabs, pervious paving, kerbs, wall copings, pillar caps...) through to funerary landscaping elements (e.g. columbaria...)



Urbastyle



The Netherlands, France, UK, Germany, Austria, Luxembourg



Ongoing market development effort



The builders' merchant trade operating on the town planning and urban development markets



Bauma (Munich), Dag Van de Openbare Ruimte (Belgium, the Netherlands)



Many years' experience, extensive know-how and a state-of-the-art precast concrete manufacturing plant have made family-owned *Urbastyle* into a prominent player in the ornamental concrete business.

Its comprehensive product range has met with the approval of many specifiers in an ever-growing number of high-profile development schemes involving urban public spaces.



The entire range of fair-faced concrete elements is available in a broad variety of finishes and textures, including smooth marble or silk lustre, grit or sand-blasted, etched, polished or blended with wooden or stainless steel highlights.

The company pursues a dynamic innovative and creativity-driven product development and customisation policy: precision casting and cutting of bespoke shapes (even small batches), allowing tailor-made concrete furniture or hard landscaping items with corporate logo imprints or with incorporated signage, coat of arms etc., multi-coloured concrete, sustainable urban drainage systems...



Member of the Flanders Concrete cluster of concrete-processing companies (www.flandersconcrete.com)



Project market mainly (civil engineering, road building and landscaping of public spaces in a built environment)



URBASTYLE

Dammeers 41 | B - 9880 AALTER

T +32 69 67 26 26 | F +32 69 67 26 27

info@urbastyle.com | www.urbastyle.com

VALÉRON STRENGTH FILMS



High-performance strength films

Valéron® cross-laminated HDPE strength films have outstanding, mechanical properties, like unparalleled strength, great dimensional stability and an exceptional resistance to impact, tear, puncture and tear propagation, making them particularly suited for highly-demanding applications in the construction industry.



© Valeron Strength Films

Products bearing the “Valeron® Inside” label differentiate themselves from other products in durability, reliability and quality.

Valéron® based products are mostly used in cold applied, self-adhesive bituminous roofing and waterproofing membranes, cavity drainage and tanking membranes, weatherproof shielding and sheathing, peel-off floorboard protection, roof underlayments, sealing and flashing tapes, underfloor heating layout films, insulating heat-reflecting membranes (HRM), sewer rehabilitation liners...

More... Valéron® films are also widely used in a host of other applications across various industrial sectors: agriculture and cattle/poultry breeding, specialist packaging, visual communication and printing...



Valéron® (HDPE), Valcross® (LDPE)



Austria, Denmark, Finland, France, Germany, Italy, the Netherlands, Norway, Portugal, Saudi Arabia, Spain, Sweden, UK



CIS countries, Estonia, Latvia, Lithuania, Czech Republic, Croatia, Serbia, Slovakia, Slovenia, Hungary, Poland, Greece, South Africa, UAE



- Building products manufacturers (water and damp-proofing membranes, strength carriers, chemical barriers, protection layers...);
- Specialty packaging manufacturers (water vapour barrier, export packaging);
- Print media manufacturers (narrow web tags and labels for imaging and identification applications, wide web banner material).

VALÉRON STRENGTH FILMS



Batimat (Paris), Salon de la Prescription (Poitiers)

Founded in 1965 and since 2000 part of ITW, a US-based construction specialty products and tools group, *Valéron Strength Films* has made its mark as a major supplier of high-quality performance films for various industries.



Valéron® is produced according to a unique 3-step cross lamination manufacturing process, using 100% fully recyclable HDPE and doesn't require the addition of foreign chemicals to achieve its high performance. Therefore *Valéron®* is truly an environmental friendly product.

The *Valéron®* production process is ISO 9001-2000 accredited, with ISO 14000 certification currently applied for. Back since 1989 the company subscribes the *Responsible Care Programme*, committed to improving health, safety and the environmental performance within the Belgian chemical industry.

In line with its corporate policy of a dedicated application-driven market approach, a dynamic product development has consistently led to a number of innovations in the area of self-adhesive (barrier) membranes and improved sustainability products like surface-treated print media, solar heat reflecting films...

Leading global suppliers of hugely successful global brands in waterproofing (*Grace Construction, Henkel Polybit, Dörken*) or in solar heat reflecting films (*Apollo Energy Research*)... or in engineered wood-based panels (*Norbord*) rely on *Valeron® Inside* for their high-specification products.

Valeron® Inside-based products have been specified in some of the highest-profile building projects, like the indoor shooting range for the Beijing 2008 Olympics (heat-reflecting membranes), the 2004 Heathrow Terminal 5 or the 1999 Dubai Palm Island and the Burj Al Arab Hotel (structural waterproofing solutions)...



Project markets (industrial, public utilities...)



© Valeron Strength Films



© Valeron Strength Films



© Valeron Strength Films

VALÉRON STRENGTH FILMS

Nieuwmoersesteenweg 145 | B - 2910 ESSEN

T +32 3 670 07 30 | F +32 3 667 35 59

essen@valeron.com | www.valeron.eu



Facing bricks and clay pavers

The product portfolio currently includes about 65 different varieties of facing bricks and some 25 types of clay pavers.

All of the machine-moulded bricks and pavers come in a wide choice of colours, surface textures and finishes (smooth, waterstruck, sanded, creased, tumbled, with multi-shade tonal variations...)

Vande Moortel bricks and pavers are successfully used in a broad range of new-build, extension, refurbishment or restoration schemes (e.g. with its range of reclaimed appearance bricks, providing a frost-resistant alternative to historically used brick varieties)

Quality monitoring: locally quarried alluvial clay from the Scheldt estuary; all products comply with the most stringent technical standards set out by Belgian (BENOR quality label, Road Paving Specification Standards) and EU certifying bodies (CE, Construction Products Directive NBN EN771-1 and EN1344 for bricks and pavers) with regard to compressive strength, durability and frost resistance, mean size tolerances, soluble salt content...

Vande Moortel

Belgium, the Netherlands, Germany, the UK, France, Austria, Swiss, Japan, Czech Republic, USA, Russia

France, Germany, UK, Ireland, Poland, Russia

Importers, distributors, builders' merchants, architects/specifiers involved in detailing building materials...

Batibouw (Brussels), BIS and Green Expo (Ghent-Belgium), IBF (Brno)

The *Vande Moortel* brickworks is a company steeped in tradition: the ancestral brickworks was set up as far back as in 1864. Over the decades, it has evolved into one of the largest family-owned manufacturers of facing bricks and leading manufacturer of fired clay pavers with an annual manufacturing capacity of 60 million brick units.

New product development drive: extensive brick-making know-how, strengthened by state-of-the-art brickmaking equipment and advanced



VANDE MOORTEEL

manufacturing techniques result in frequent additions of new shades, surface finishes and shapes (e.g. the Dialogue line of purpose-developed novel and special brick types), regular additions to the brick and paver ranges (e.g. bricks for thin-joint glued masonry, new trendy colour shades to the Nature series or to the Linea line of ultra slender bricks, specially developed to create a delicate linear appearance in brickwork with thin or recessed jointing), introduction of new types of matching jointing materials (crushed rock fines)...

Environmental considerations:

Apart from clay being a natural and fully recyclable raw material, the company consistently invests in innovative production technology reducing the environmental impact of brickmaking and restoring depleted clay quarries into valuable landscape elements.

In the company's vast indoor showroom and outdoor exhibition area the entire bricks and pavers range are showcased on full-storey height masonry facades and full-size paving areas for prospective buyers to view in all their splendour.

Its well-designed website features, technical specifications reports, laying instructions and bond patterns, an interactive brick and paver selector tool aimed at architects/specifiers and an impressive number of national and international reference projects in residential, commercial and landscaping applications

Residential and project markets



VANDE MOORTEEL

Scheldekant 7 | B - 9700 OUDENAARDE

T +32 55 33 55 66 | F +32 55 33 55 70

info@vandemoortel.be | www.vandemoortel.be

VANDERSANDEN



Moulded facing bricks

The impressive catalogue, showcasing as many as 65 brick varieties, is split up into 5 distinctive lines, each including brick types with their own particular natural tonal variations, ranging from retro-moulded, reclaimed appearance bricks to more contemporary and architecturally challenging shades. A charmingly creased and delicately sanded texture is a feature common to all *Vandersanden* bricks, some of which are available in as many as 4 sizes, either standard or bespoke.

All top-quality bricks by the ISO 9002-2000 certified *Vandersanden* company have a high compressive strength, optimum frost/thaw resistance, are low on water absorption and show no efflorescence.

Backed by authoritative independent third-party quality certification (BENOR, KOMO, BSB, Baustoffüberwachung...), the entire brick range largely surpasses the most stringent national and international test requirements.

More... range of matching special shaped bricks and brick slips: angle bricks, bullnose bricks, cant bricks, coping and capping bricks, corner slips...



Finesse, Présence, Nostalgie, Attitude, Impulse



Europe, Japan



Worldwide marketing effort ongoing



Professional builders' merchant trade, architects, specifiers, contractors



Batibouw (Brussels), Nordbat (Lille), BIS (Ghent) and a number of Belgian regional trade fairs: Bouwinnovatie (Hasselt), Habitat (Liège) and Batirama (Tournai)



Drawing on a history in brick-making dating back 80 years, the *Vandersanden* company has managed to consolidate its market leadership in Belgium and made a name for itself as one of the leading manufacturers of top-quality facing bricks.

The company boasts some of Europe's most advanced brick manufacturing plants. 3 production facilities on Belgian

VANDERSANDEN

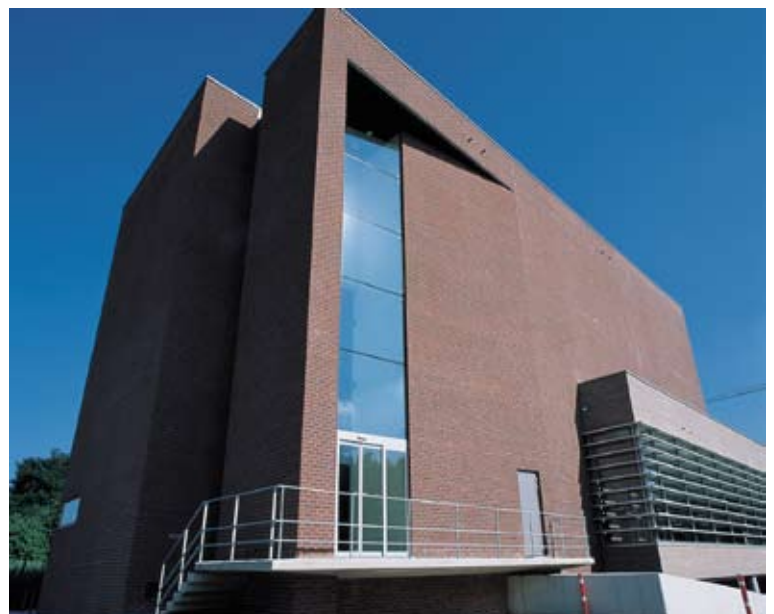

VANDERSANDEN

soil have a combined annual capacity of 265 million bricks, with 3 Netherlands-based factories (through the 2005 *Huwa-Vandersanden* joint venture) adding a further 200 million units.

Some 50 % of total output is destined for export across Europe and as far as Japan.

The company is committed to continued innovation and product development in response to changing customer demands across the construction industry, resulting in regular roll-outs of new brick types, colour shades and textures, suited for a wide variety of both new-build and refurbishment schemes.

The company is known for its unparalleled service and customer support, swift deliveries, implementing flexible manufacturing, professional advice, both on and off-site and a consistent customer-oriented, solutions-led approach, supported by extensive multilingual product literature.

Well-devised, multilingual website, featuring an encompassing database of finished reference projects, comprehensive technical guidance and a nifty interactive design tool, aimed at both architects and future home-owners, allowing various selection options as to the type of bricks, coloured pointing, bond patterns...

The company is committed to achieving high levels of environmental performance through the use of all-natural raw materials (some of them reclaimed), restoration projects for depleted quarry sites, state-of-the-art energy-efficient kilns and by operating sustainable packaging and emission reduction schemes (zero wastewater emission, flue-gas scrubbing...).

The company was granted the 2005 *FEMA* (Belgian Builders' Merchants Federation) Award and the 2006 *Trends Gazelle* award for outstanding business development and performance.

Both residential (private and public housing...) and non-residential projects (commercial and public buildings...)



VANDERSANDEN

Riemsterweg 300 | B - 3740 SPOUWEN (BILZEN)
T +32 89 79 02 50 | F + 32 89 75 41 90
info@vandersanden.be | www.vandersanden.be

Facing bricks

Terca branded, richly varied range of handcrafted and mechanical facing bricks and slip bricks, available in a myriad of different colours, textures and sizes and with the greatest quality guarantees.

This extensive selection opens up unlimited design opportunities meeting wishes, style and visions of architects, developers and planners. Terca bricks most successfully combine aesthetics, tradition and innovation.



Clay pavers

Under the same Terca brand name, Wienerberger also offers an extensive range of clay pavers in a large pallet of sizes, colors and finishes (creased, tumbled, sanded, contemporary or reclaimed appearance). Terca clay pavers are colourfast and highly valued for their lasting, natural beauty.

Innovatively, the range was developed to include the *Trendline* series of identically hued bricks and pavers, allowing a seamless, uniform look in brick building and paving projects.

Hollow bricks

Encompassing portfolio of various types of *PoroTherm* branded hollow bricks for use in various building types. Applications are in loadbearing cavity wall masonry or in non-loadbearing infills or partition walls. These bricks have excellent thermal and sound insulation, heat accumulation, fire resistance and moisture regulation properties.

Each type is available in different sizes, various compressive strength levels and insulation grades, for traditional mortar-bonded, tongue-and-groove or glued brickwork.

ArGeTon **ceramic cladding elements** are available in various colours (ranging from brick red, across glacier blue to pearly white), 4 standard lengths (more on a bespoke basis) and a choice of surface textures (smooth, varnished, brushed, grooved). *ArGeTon* cladding panels feature in numerous international high-specification architectural schemes, perfectly blending with other building materials used in contemporary architecture like glass, steel, aluminium,...



Clay roof tiles

With a 120-year pedigree to its name, *Wienerberger's* leading *Koramic* clay roof tile brand includes a vast array of roof tile designs (plain tiles, beaver tail tiles, pantiles, interlocking flat tiles and pressed tiles), sizes, in various color shades and surface texture finishes (natural, engobed, sanded, reduced, glazed, satiny, noble engobed).

All roof tile models come with a full array of complementary detailing products and fittings, including ridges, valleys, hips, ventilation tiles... All of them are covered by a standard 30-year frost-resistance warranty and bear comprehensive international product certification and quality approval.

Designed to cater for varying degrees of roof pitches (from as little as 10%), batten spacings and

WIENERBERGER

covering widths, *Koramic* roof tiles are ideally suited for many roofing and cladding applications in new-build, refurbishment or extension projects, matching any regional building requirement and tailored to any architectural roof design.



Terca, Porotherm, ArGeTon, Koramic



International manufacturing and sales presence across Europe and in the US



Ongoing strategic expansion and market consolidation in existing markets and continuing marketing effort in key export markets



Distributors, importers, developers, (landscaping) architects, builders' merchants, town planning officials...



Wienerberger is represented at all major international building events: Interbuild, Big 5, Batimat, Bygg Reis, Nordbat, Batibouw, Construmat...



Operating over 260 production sites in as many as 25 countries, *Wienerberger* is the world's largest producer of bricks and Europe's second largest manufacturer of clay roof tiles. It also holds a leading position on the European clay pavers market.

Some of *Wienerberger's* flagship products - in the hollow bricks, facing bricks and roof tile ranges - are made in one of its 20 Belgian plants.



Research and product development: driven by a close partnership with architects, developers, builders' merchants and local planners, the company implements a continued research and innovative product development policy, resulting in regular additions of new aesthetically enhanced, technically improved or environmentally sound products to the existing portfolio.

The company implements a policy of sustainability by improving the energy-efficiency of its manufacturing plants, by introducing emission-reducing environmental technologies, involving in redevelopment schemes of depleted clay mining areas and through successful R&D work on innovative products for sustainable construction schemes.

The company is set to maintain its quality leadership through continuous quality monitoring, marketing a product range fully compliant with the most stringent international building products regulations and offering its customers a service level that is second to none.

Its well-designed website features material selector tools, specification documents, technical data sheets and finished site reference material for both prospective home-owners and architects.



With the product portfolio being as broad as it is, both consumer and project markets are targeted with applications in new-build, refurbishment and conservation schemes alike.

WIENERBERGER

Ter Bede Business Centre | B - 8500 KORTRIJK

T +32 56 26 43 45 | F + 32 56 26 43 32

export@wienerberger.com | www.wienerberger.com

MEET THE BUILDERS...

Agoria Construction Products

Within Agoria, the 1400-member, multi-sector trade association for the Belgian technology industry, the construction products branch represents those 250 companies involved in the following construction-related lines of business: structural steel construction, metal joinery and furniture (industrial doors, curtain walling, solar screens, locks...) HVAC systems, lifts and escalators, heating and sanitary equipment, fire technologies, shelving and storage solutions, lighting, building plastics, electrical and electronic components or systems for the construction industry.

www.agoria.be

Aluminium Centre

The Aluminium Centre represents some 80 companies, either manufacturing, processing or applying/ incorporating aluminium. Its main aim is to promote the use and specification of aluminium(-based) products in a broad spectrum of applications by providing information, fostering innovation and encouraging technology transfer.

www.aluminiumcenter.be

Belgian Brickmakers' Association

The Belgian brickmakers' association promotes the design, detailing and specification of clay bricks and pavers in structural, architectural and landscaping applications across the construction industry.

www.baksteen.be

Belgian Building Research Institute (BBRI)

Research institute and leading centre of expertise performing scientific and technical research on behalf of its members (some 65 000 Belgian construction companies (general and specialist contractors, floorers, carpenters...) and supplies them with technical information, assistance and consultancy.

The institute performs contract research upon request of the industry and the authorities.

www.wtcb.be

Belgian Construction Certification Association (BCCA)

BCCA, partnered with government, is a specialist certification body for the construction sector, providing authoritative and impartial information and certification on the performance of building products and systems, processes and quality management schemes. It is also the Belgian accredited body with a mandate to issue the CE-marking.

www.bcca.be

BMP

The Belgian Construction Materials Manufacturers was set up to federate 14 Belgian trade associations, which –together– cover all kinds of construction materials and building products: precast concrete, wood and timber, bricks and fired clay products, building plastics, plaster, fibre cement, quarry and mining products, steel, glazing, ready-mixed concrete, bituminous waterproofing and mineral wool insulants.

www.bmpmc.be

BENOR-ATG

BENOR and ATG are 2 major (voluntary) Belgian product quality marks on construction materials. BENOR confirms their compliance with either the governing Belgian NBN or PTV (technical product specification) standards.

ATG (Technical Agrément) offers evidence of performance on one particular building product, manufactured by one particular company suited for a specific construction application. ATG labels are mainly affixed to building systems, construction products consisting of various components and to innovative building materials, for which dedicated product standards are yet to be issued.

www.benoratg.be

Bouwunie

Part of UNIZO - Flanders' leading inter-professional organisation, representing some 8500 independent entrepreneurs and small and medium-sized companies- Bouwunie (Builders' Union) is the representative umbrella organisation of 6 dedicated professional trade bodies including builders, carpenters, painters, plasterers, wiring, pipework and road works contractors.

www.bouwunie.be

Febe

Belgian trade association of precast concrete manufacturers and its 13 constituent product associations, covering structural precast concrete components, precast flooring, concrete block paving and kerbing, building blocks, architectural cladding, concrete pipeline systems...

www.febe.be

Febelhout

Belgian wood-processing federation, representing manufacturers of (engineered) timber construction elements (floors and flooring, structural timber trusses, joists, carpentry, sheets and wood-based board materials...), furniture, timber packaging and other finished/semi-finished products.

www.febelhout.be

MEET THE BUILDERS...

Feproma - Fema

The Feproma association represents over 50 of Belgium's major manufacturers of quality building materials, sold through the distribution network of Fema, the Belgian builders merchants' federation, representing some 200 companies involved in the building supplies market.

IWT

One of the tasks of IWT, the Institute for the Promotion of Innovation by Science and Technology in Flanders, is to facilitate the search of local enterprises for technological partners. On a European level it harbours IRC-Vlaanderen, a member of the Innovation Relay Centres network set up by the European Commission to facilitate innovative technology transfer throughout the EU.

www.iwt.be

Living Tomorrow

The Living Tomorrow project, currently in its 3rd edition, is basically a demonstration house, incorporating innovative building technologies, ideas and concepts into a real-life living environment (kitchen, home office, workspace).

These technologies are aimed at enhancing comfort and improving the quality of living, working, shopping... in the (near) future, with particular attention to sustainability (energy-efficiency, sustainability). Some 80% of the technologies on display are "near market". The Living Tomorrow 3 site also acts as a test bed for innovative companies to try out innovative products, systems and services on real-life visitors (and future consumers) and to seek feedback as to their acceptance.

VCB

The Flanders Building Confederation is the principal trade body representing the construction business in Flanders. Its 9000-company membership includes major international contractors, SME's and independent entrepreneurs alike, from all areas of the building trade: general contractors, public engineering companies, road builders along with fitting contractors and the finishing trades.

Among its 10 constituent trade associations are those representing general contractors, carpenters/joiners, wood plank flooring contractors, roofers, installers of suspended ceilings, partition walls and access flooring, roofing, glazing, flooring/tiling contractors, HVAC installers, electricians.

www.vcb.be

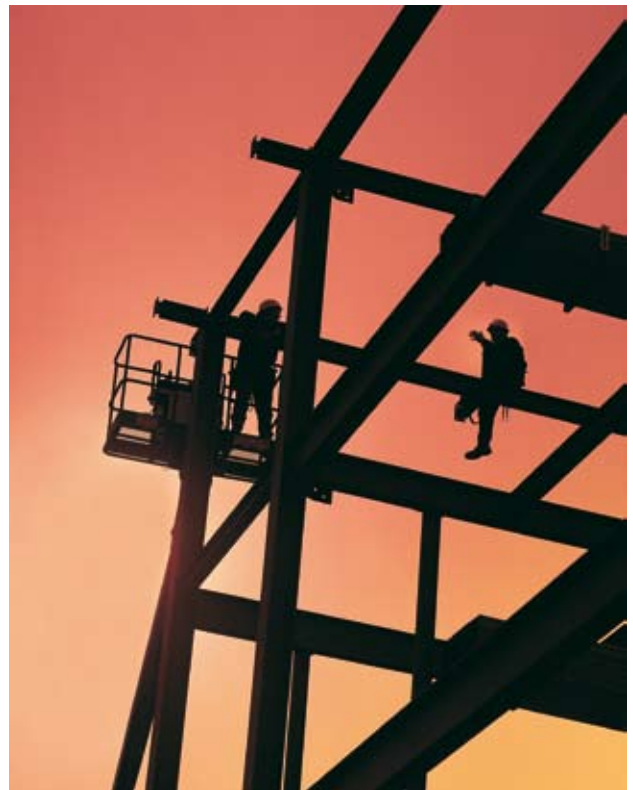

... AT THE BUILDING EVENTS IN FLANDERS

Architect@Work

Partnering event geared to architects, interior designers and consulting engineers.

www.architectatwork.be

Batibouw

International building, renovation and interior finishings fair

www.batibouw.be

Betondag

Leading annual partnering and networking event for those professionally involved in the concrete building business.

www.betondag.be

BIS (Bouw- & Immosalon)

Leading annual building fair in Flanders

www.bisbeurs.be

Green Expo

European trade fair for garden, landscaping, parks and public green spaces

www.green-expo.be

Industrie- en Projectbouw

Professional niche trade fair for industrial and utility construction

www.easyfairs.com

Interieur

International biennial for creative interior design

www.interieur.be

Matexpo

International bi-annual trade fair for machinery, equipment and technology for the construction industry, roadbuilding, recycling, public works schemes and industry in general.

www.matexpo.com

Prowood

Belgium's single-most important international trade fair aimed at manufacturers, importers and suppliers of various woodworking categories: from products for interior fittings (parquet, laminate) to wood finishing products, software systems, woodworking and treatment machinery, safety systems, boarding material and hardware for the furniture and construction industries...

www.prowood.fair.be

DIY

Annual trade fair for the home improvement market.

Product mix: interior decoration, electrical and sanitary installation, building materials, gardening supplies, ironmongery, wood and timber, power tools

www.diy-xpo.be



© Wienerberger

COLOPHON

Building and Construction Materials (SG5-07/07)

Responsible editor:

Koen Allaert, managing director FIT

Report researched and compiled by:

FIT Communications Department:

Renaat Van de Putte

Design, prepress and printing:

FIT Communications Dept.:

Lucienne Steenacker

All trademarks and photographic materials remain the property of their respective owners.

Cover pictures are courtesy of Argex, Vande Moortel and Kerkstoel 2000

Reproduction is authorized.

Source acknowledgement would be much appreciated.

This report does not claim to be an exhaustive directory of all Flemish companies involved in the sector under review.

Abidjan
Algiers
Athens
Atlanta
Bagdad
Bangalore
Bangkok
Barcelona
Beijing
Belgrade
Berlin
Birmingham
Bogota
Bordeaux
Bratislava
Bucharest
Budapest
Buenos Aires
Cairo
Casablanca
Chicago
Cologne
Copenhagen
Damascus
Dubai
Dublin
Edinburgh
Geneva
Guangzhou
Hanoi
Havana
Helsinki
Hong Kong
Islamabad
Istanbul
Jakarta
Johannesburg
Kiev
Kinshasa
Kuwait
Lille
Lisbon
Ljubljana
London
Los Angeles
Lyon
Madrid
Manila

Mexico City
Milan
Montevideo
Montreal
Moscow
Mumbai
Munich
Nairobi
New Delhi
New York
Nizhny Novgorod
Osaka
Oslo
Paris
Poznan
Prague
Riyadh
Rome
Santiago
São Paulo
Seoul
Shanghai
Singapore
Sofia
St. Petersburg
Stockholm
Stuttgart
Sydney
Taipei
Tashkent
Teheran
Tel Aviv
The Hague
Tokyo
Toronto
Tripoli
Tunis
Vienna
Vilnius
Warsaw
Zagreb
Zurich

