



Budapest University of Technology and Economics
Department of Construction Technology and Management

Construction Equipment Lifting & Transporting

Edited by: Dr. Zoltán A. Vattai

Budapest, 2010

Reconstruction of a roman crane

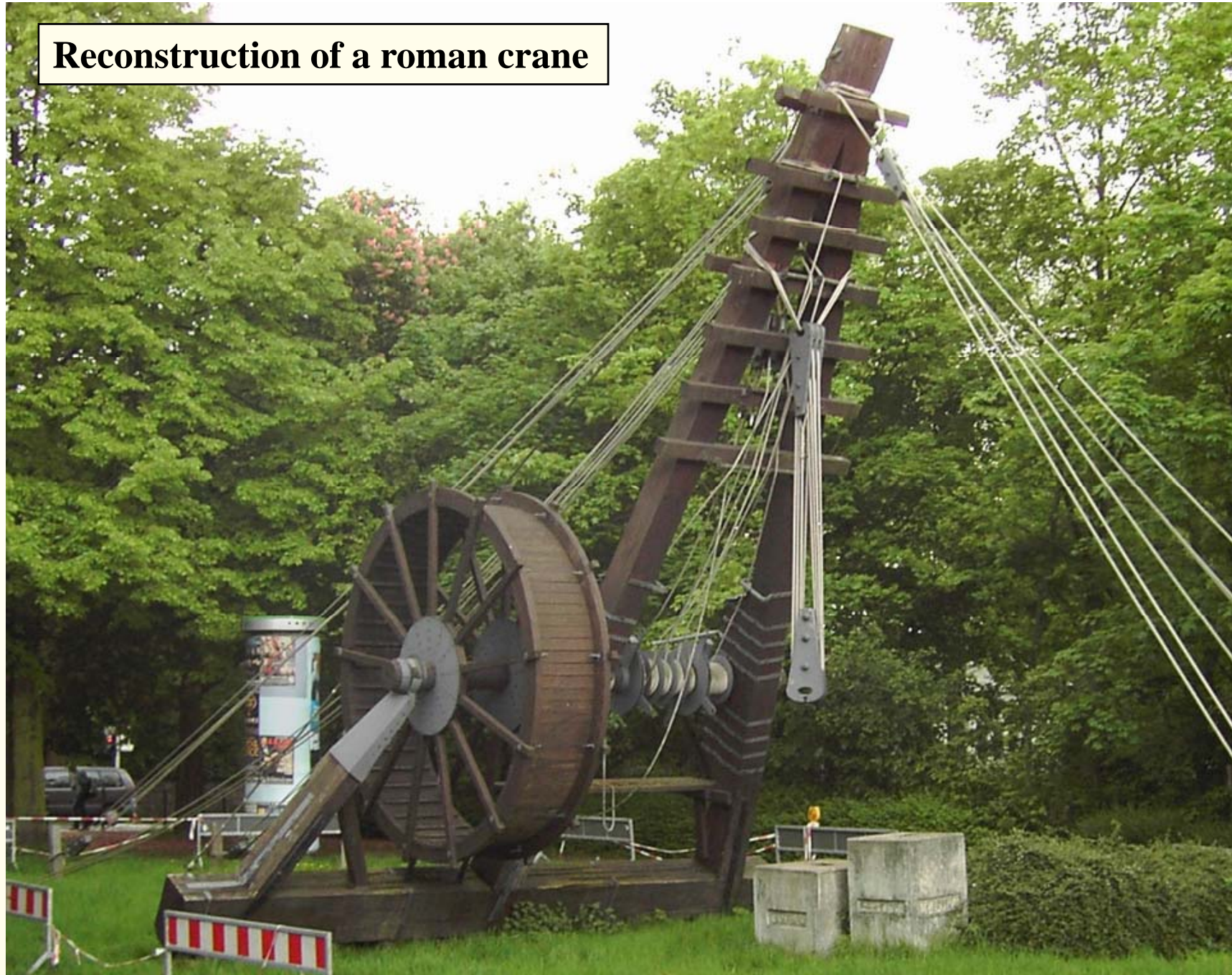



Reconstruction of the temple of Jerusalem



Treadle crane (Bruegel)

Roman Trispasos

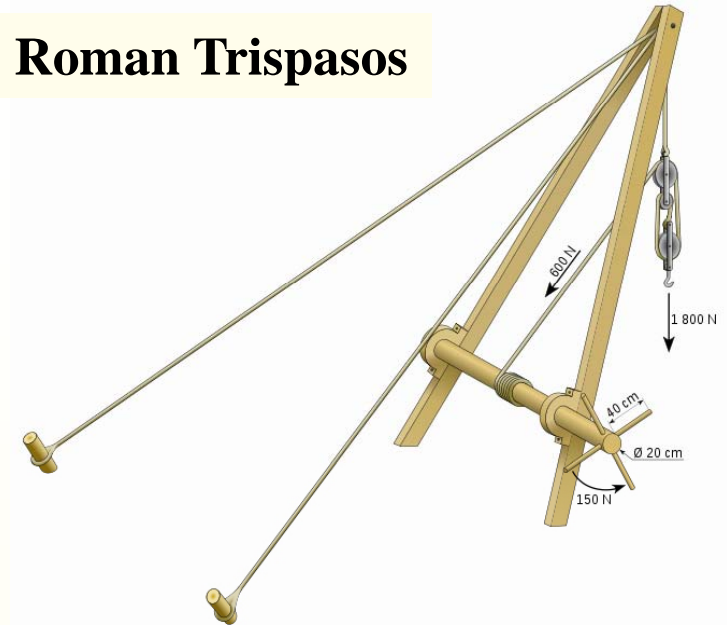

Roman Pentaspasos

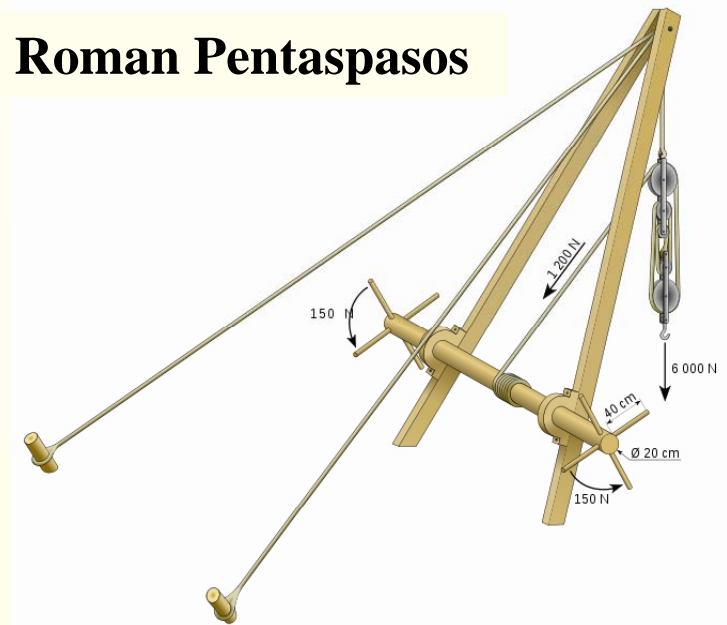

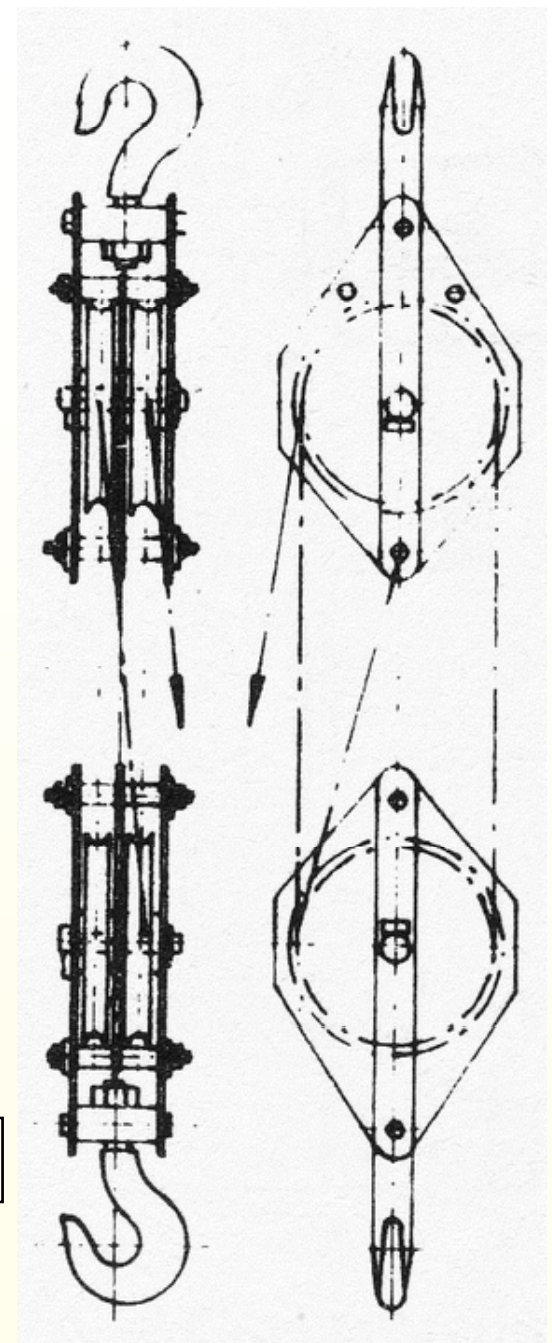
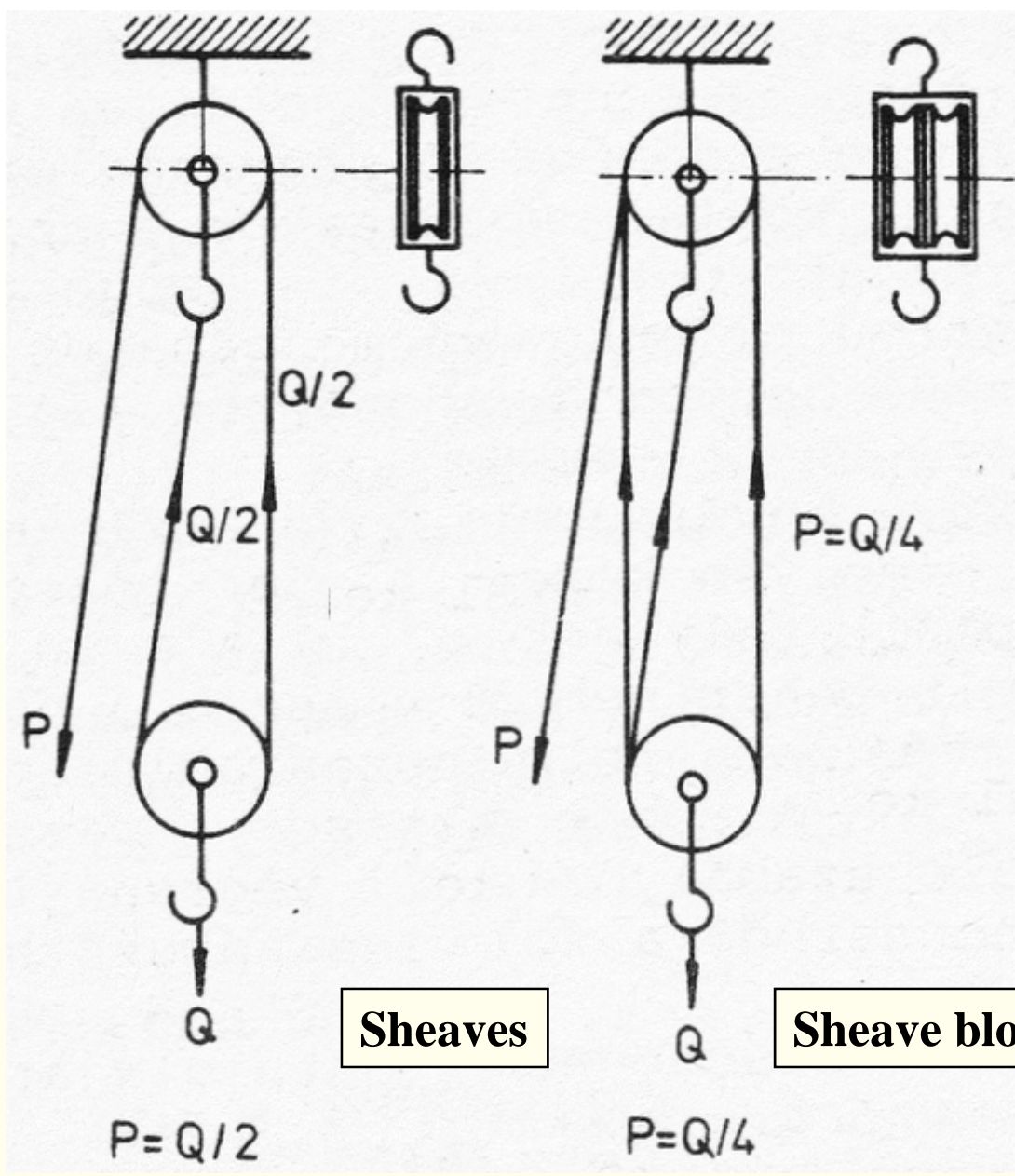

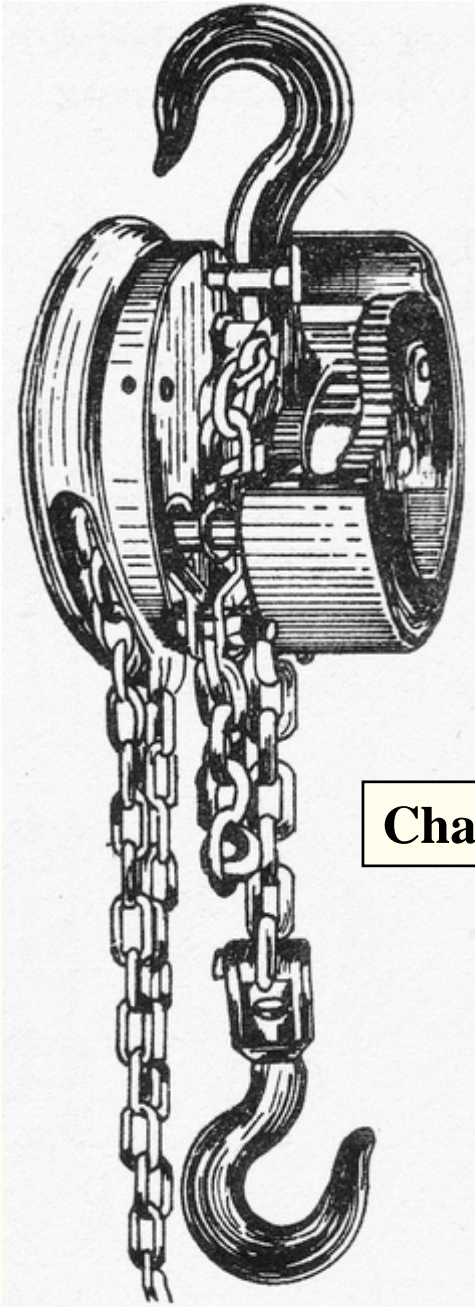

Chain pulley

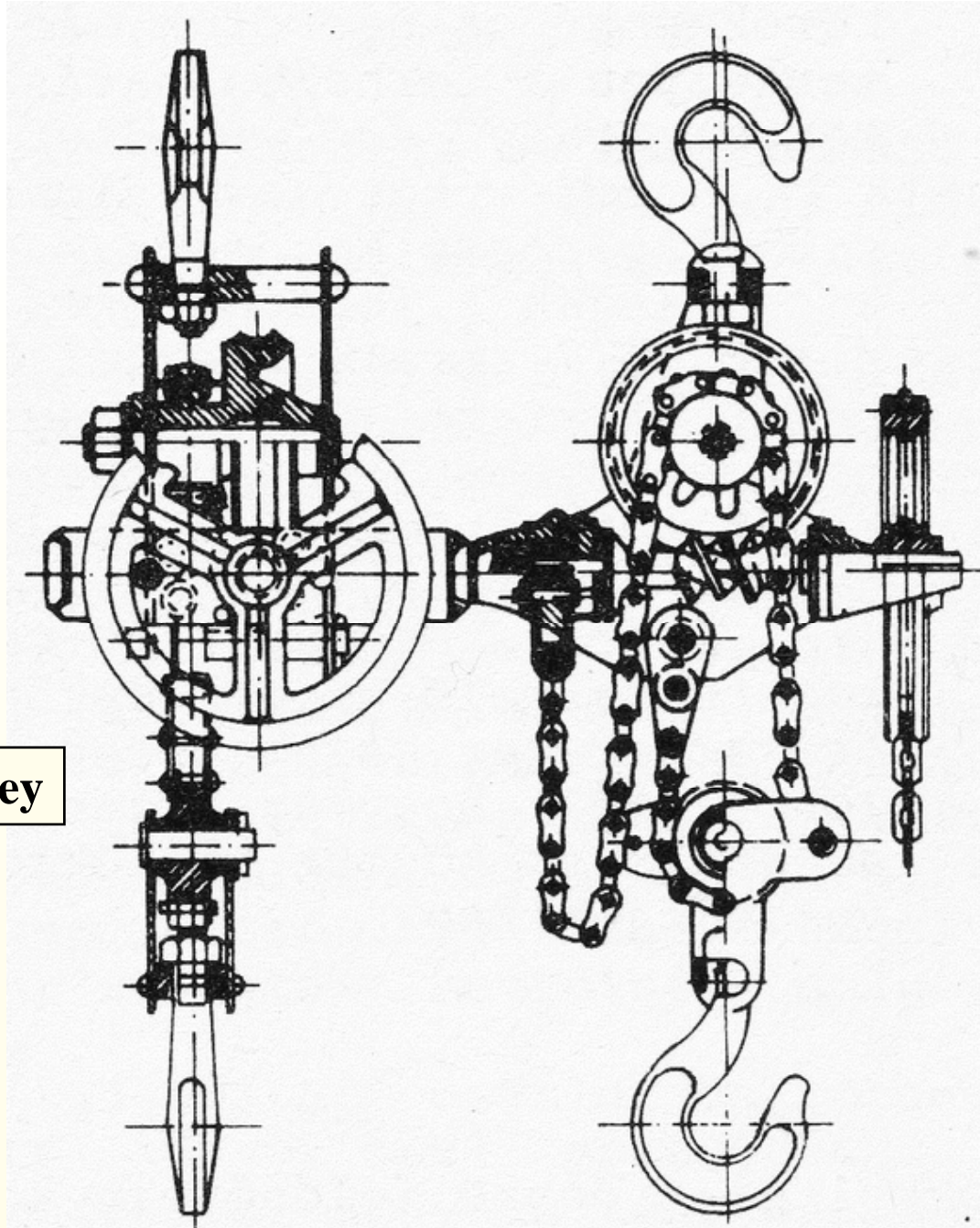

Manual winch

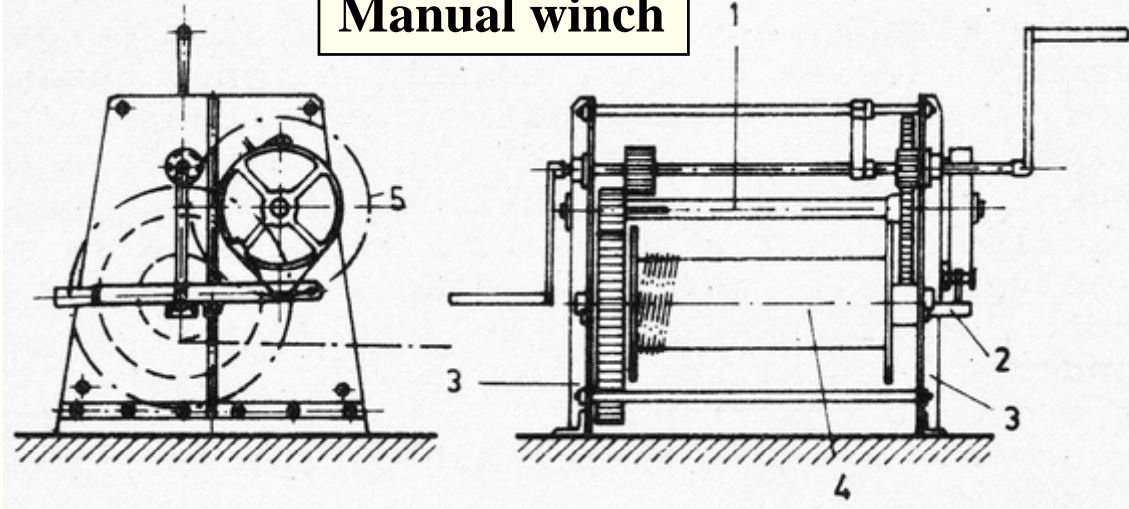

Machine winch

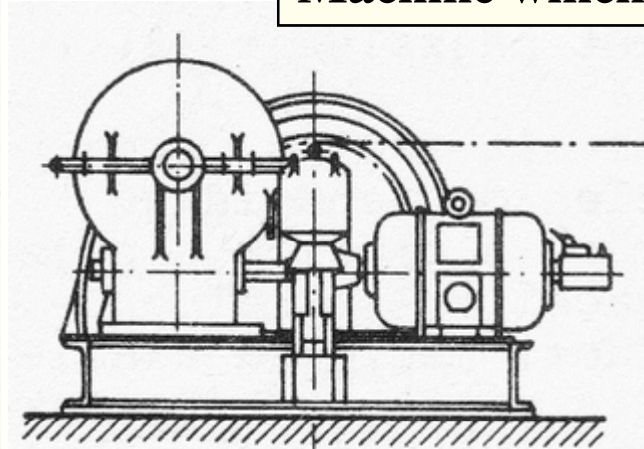

1. driving- and gear shaft
2. layshaft of the drum
3. fastening plate
4. draw drum

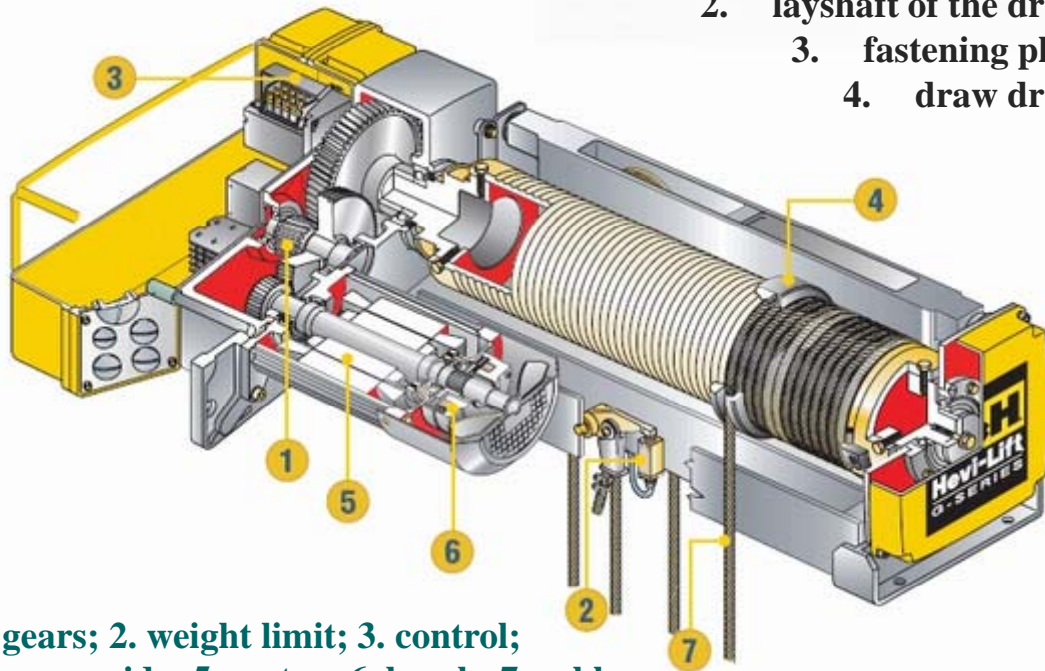

1. gears; 2. weight limit; 3. control;
4. rope guide; 5. motor; 6. break; 7. cable

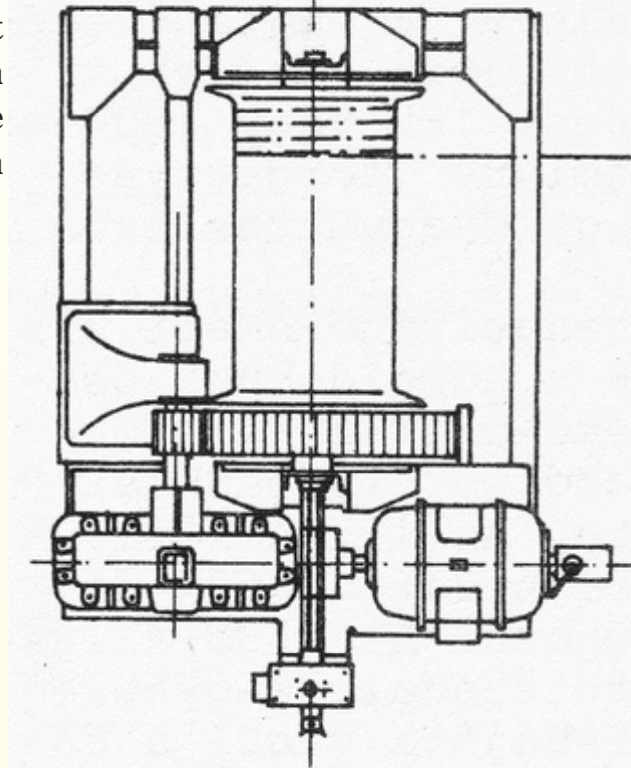

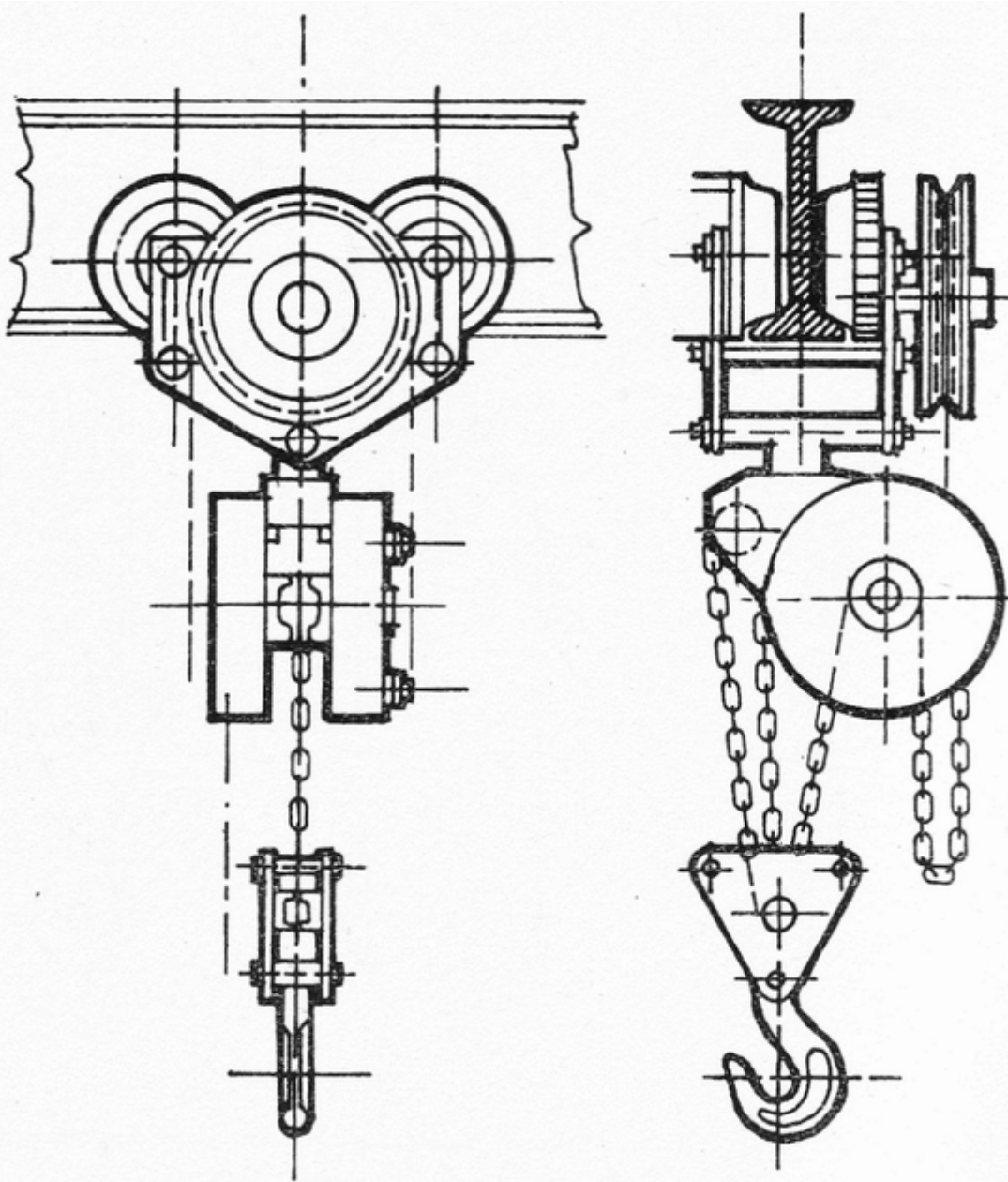

← Crane Crab

Gantry Crane

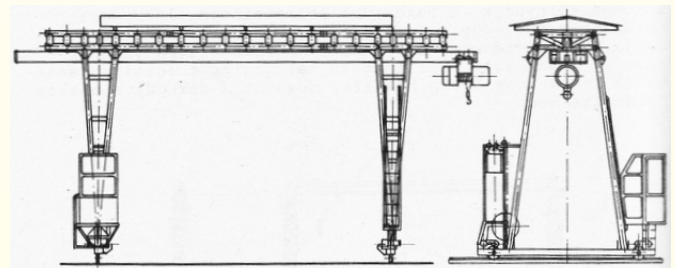

**rail mounted , two-cantilevered
Gantry Crane (Portal Crane)**

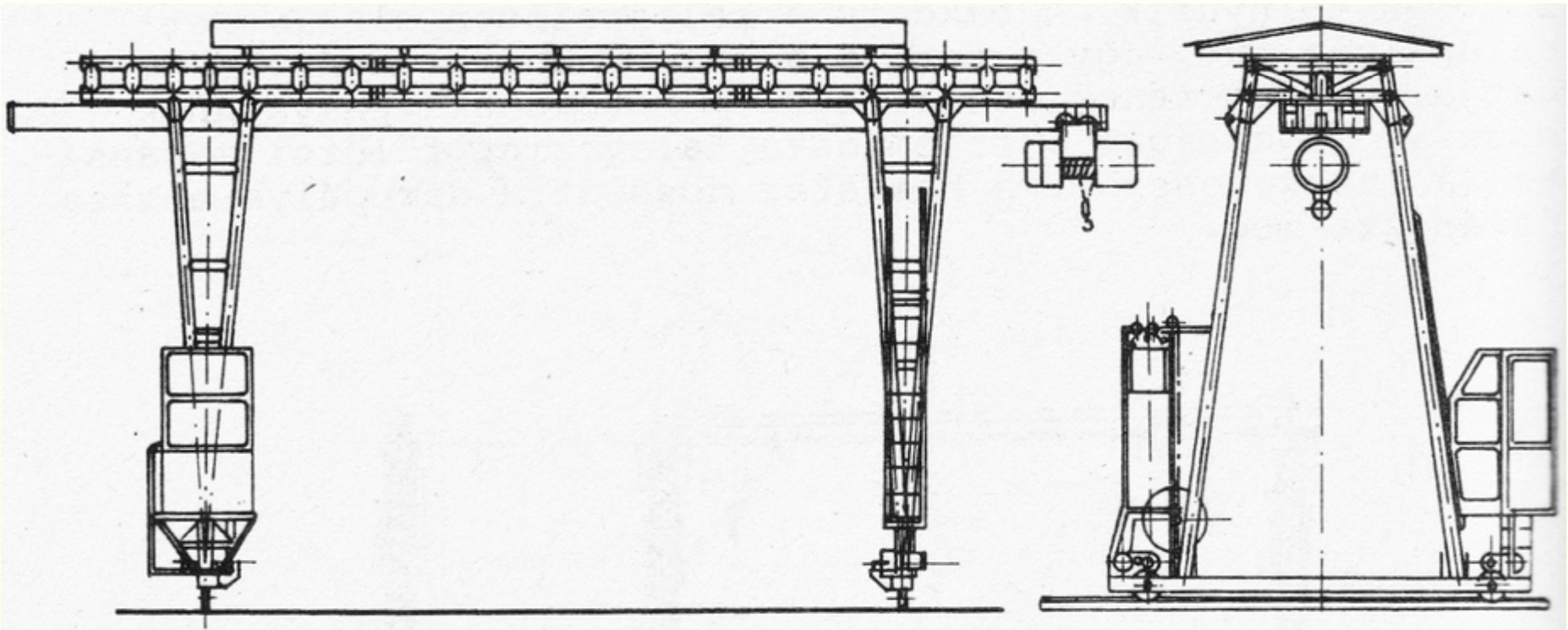

Cable Crane

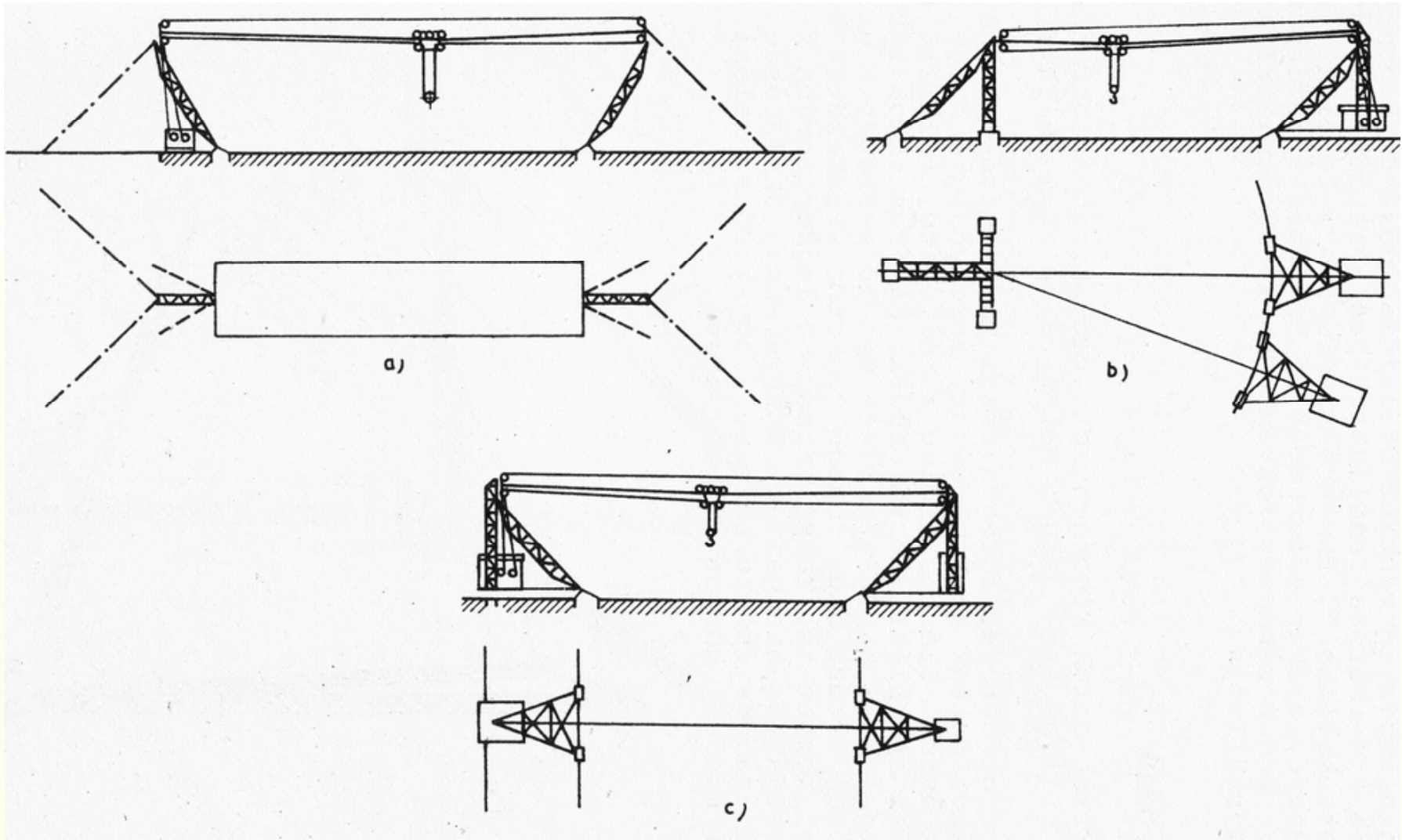

a. fix crane posts; b. fix post + curved rail mounted; c. parallel rails mounted

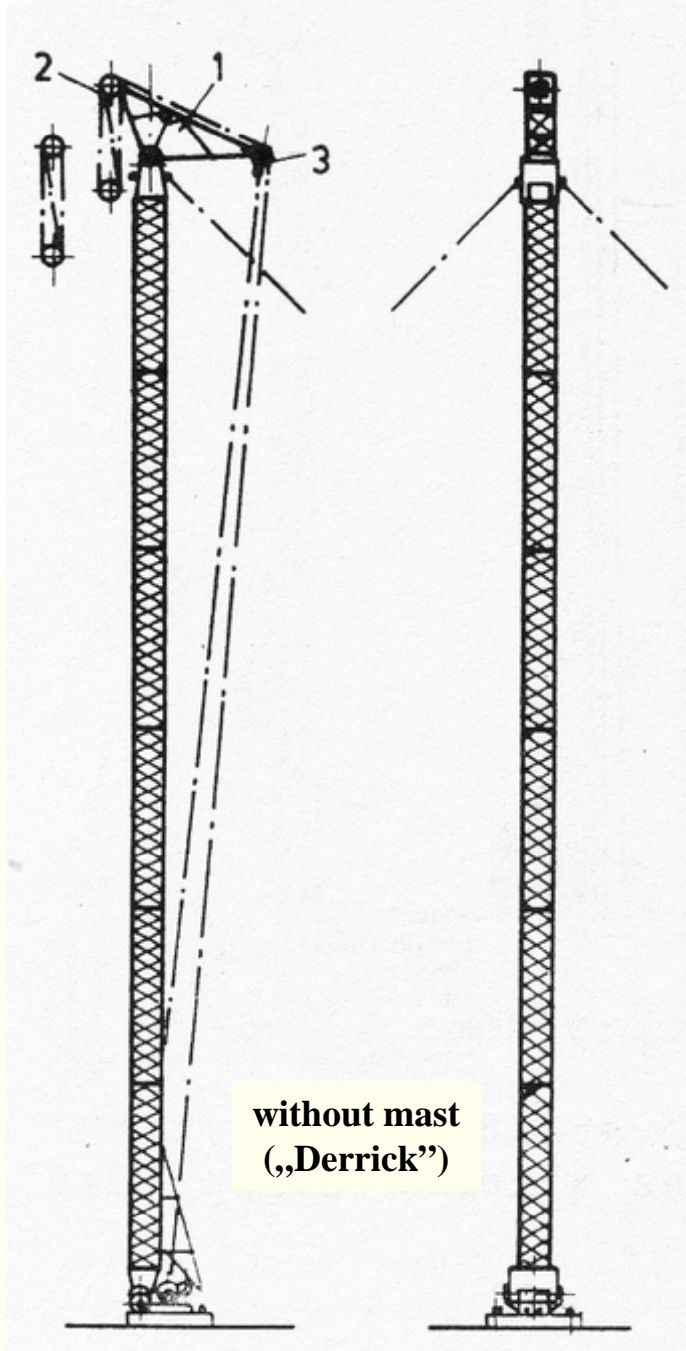

without mast
(„Derrick“)

Derrick Cranes

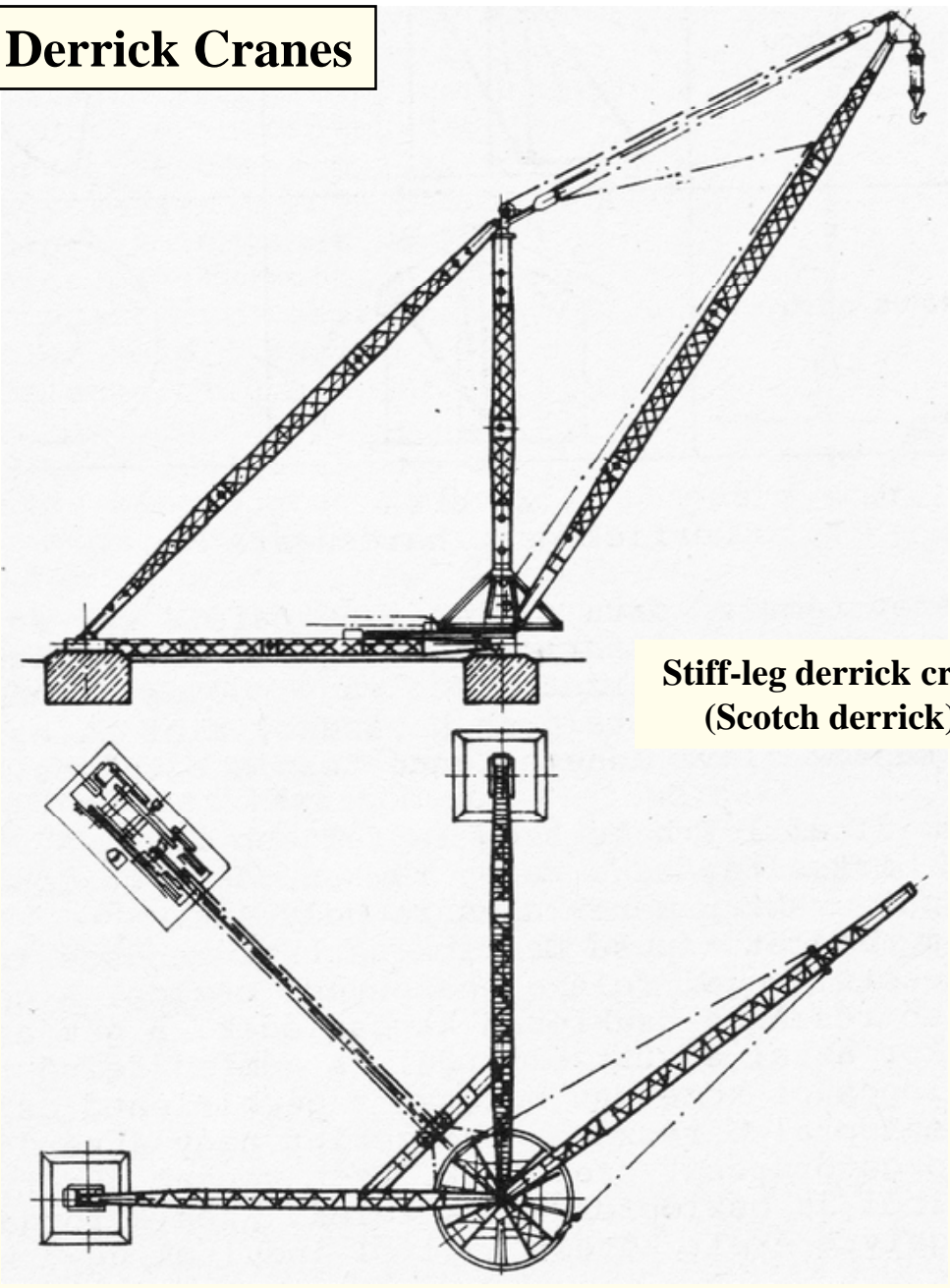

Stiff-leg derrick crane
(Scotch derrick)

Tower Crane

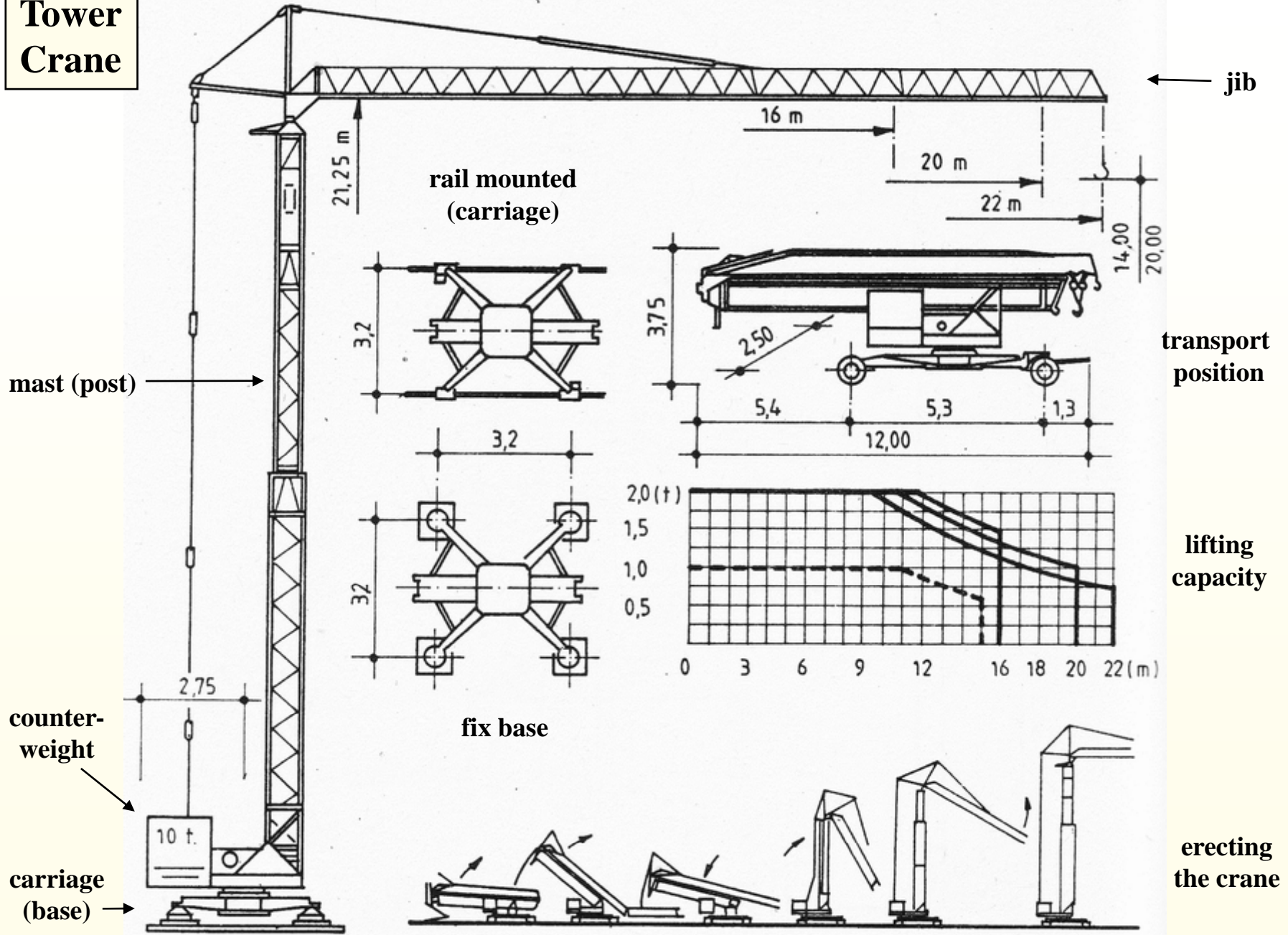

Tower crane carriage (bogie)

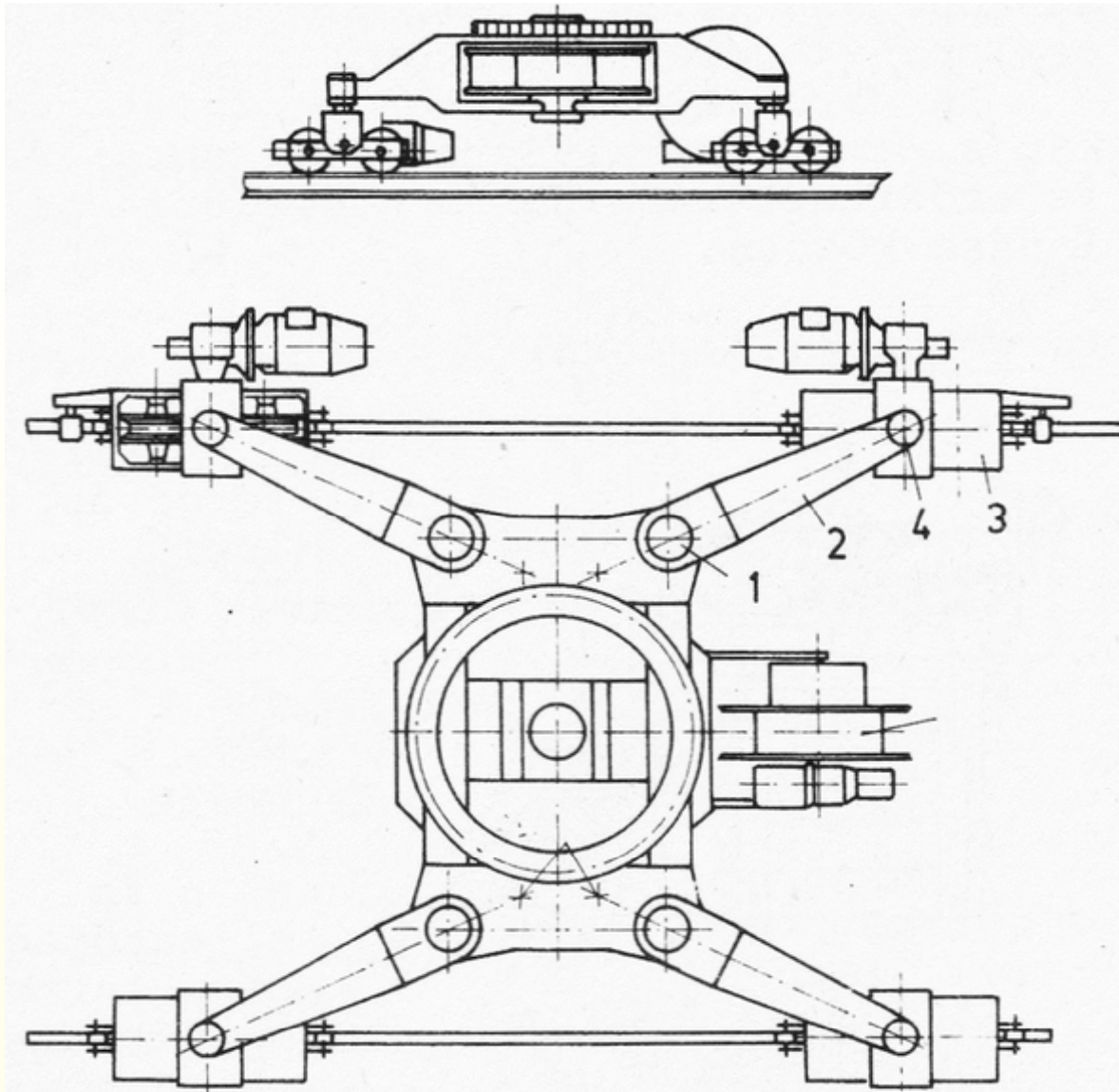

1. pivot; 2. box girder; 3. wheel-box; 4. king-pin

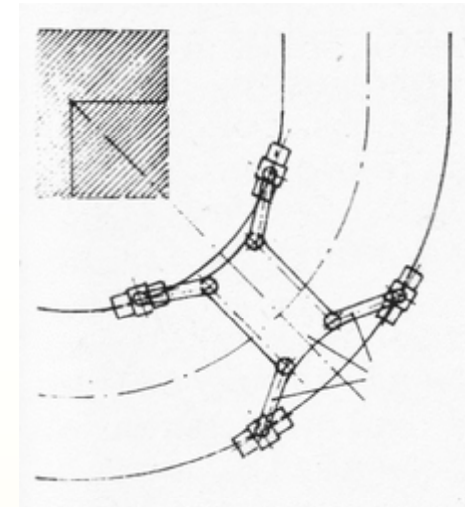

Grip break

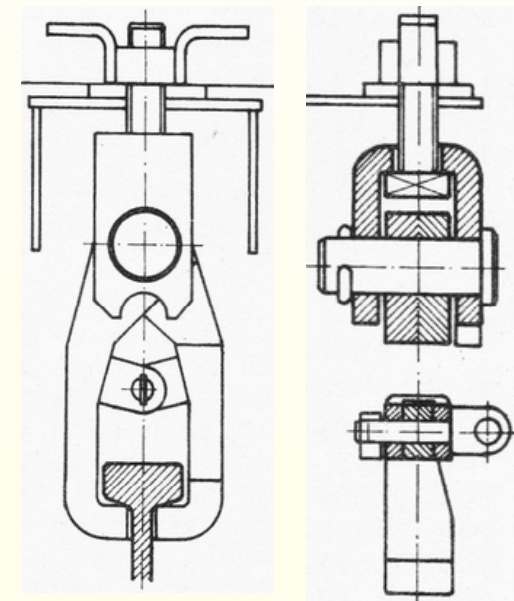

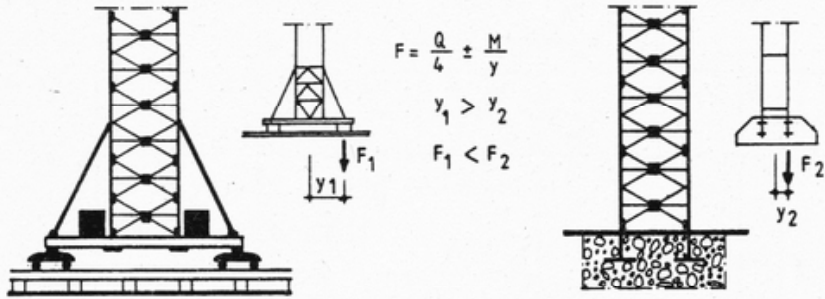

**Bases and
braces of
tower
cranes**

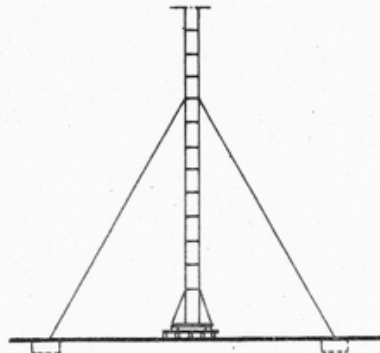
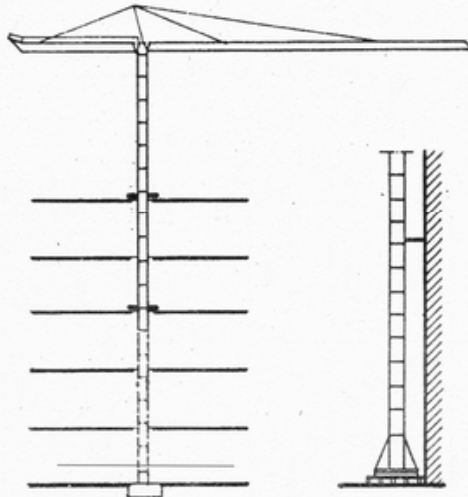
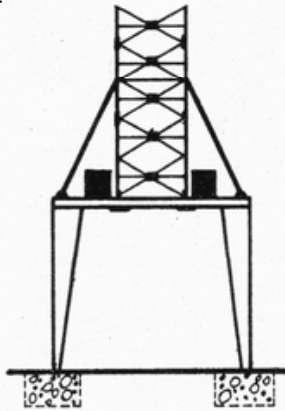

a-b. on trailer(s)

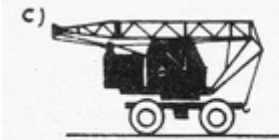
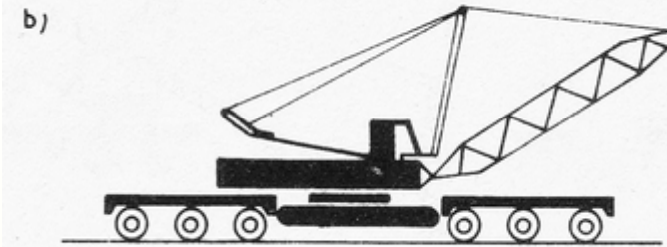
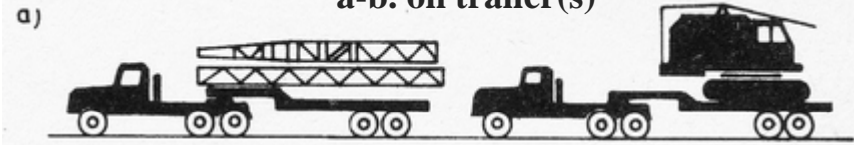

c. with folded boom

**Transporting
tower cranes**



d-e. with retracted boom

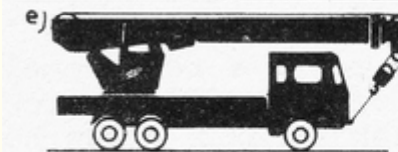

f-g. long vehicle (train)

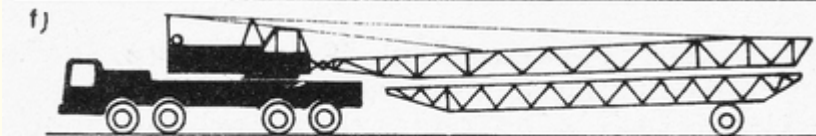

Calculating necessary hook-height (H)

Lifting capacities

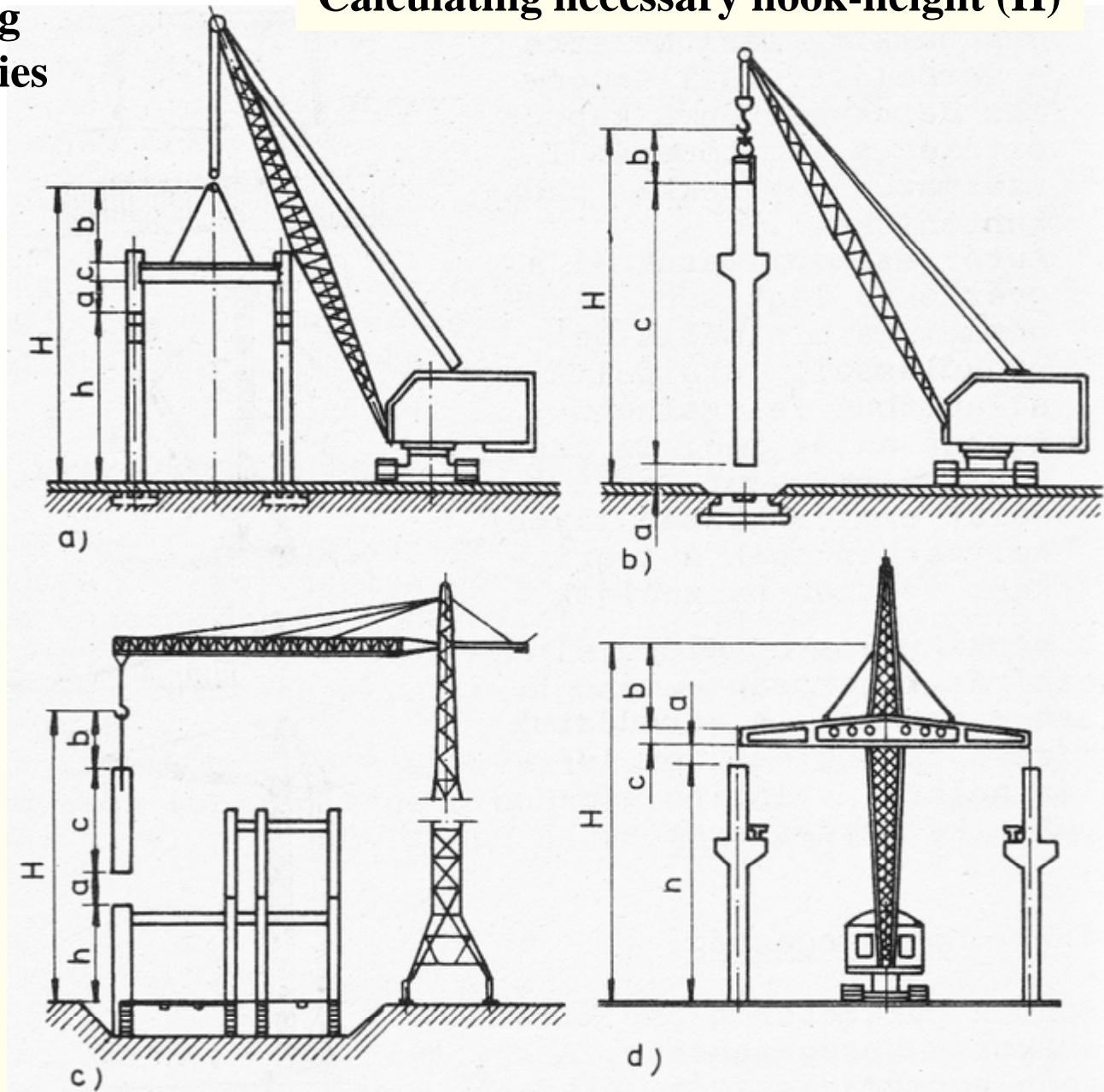
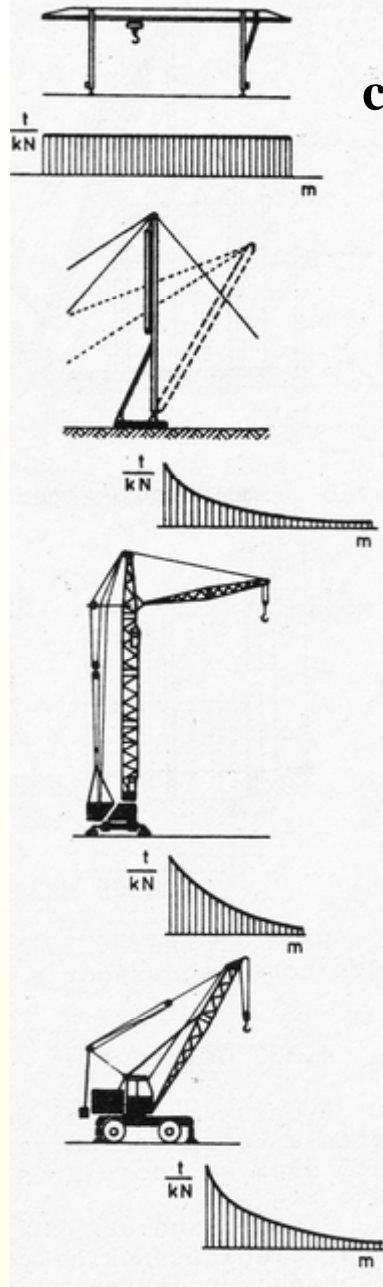

a. hogging; b. spreader height; c. member height; h. level of placement less level of crane footing

Climbing Crane

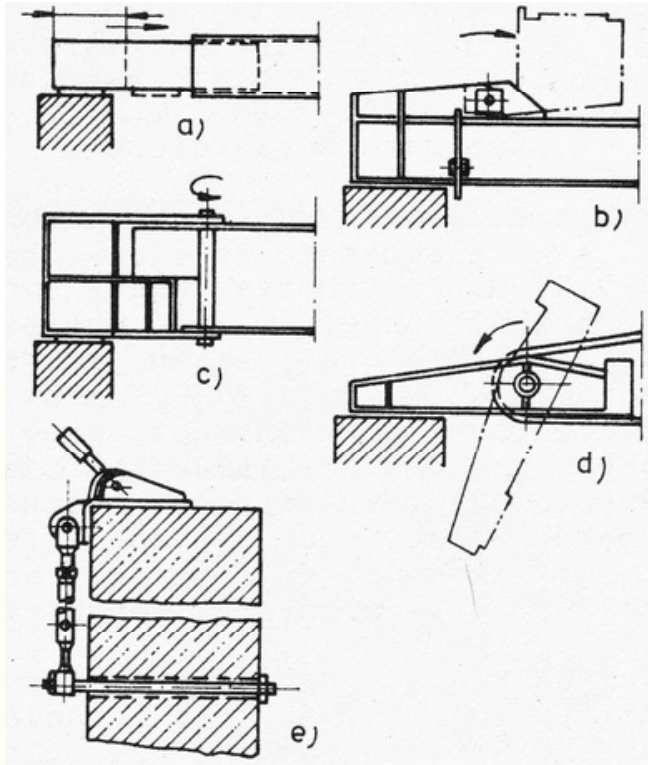

a-e. different types of bearings of climbing cranes

Load-bearing structure of the building must be designed for the weight and climb of the crane

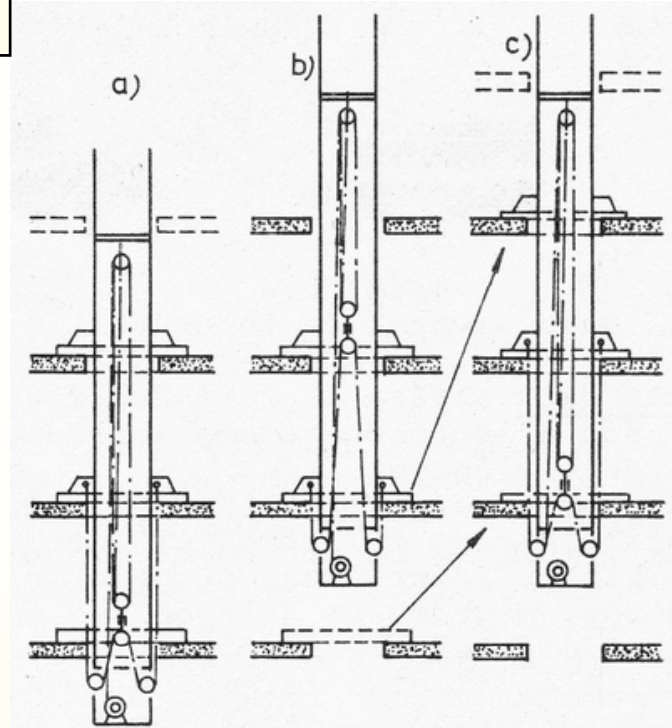

a. start position; b. climbing; c. preparation for next climb

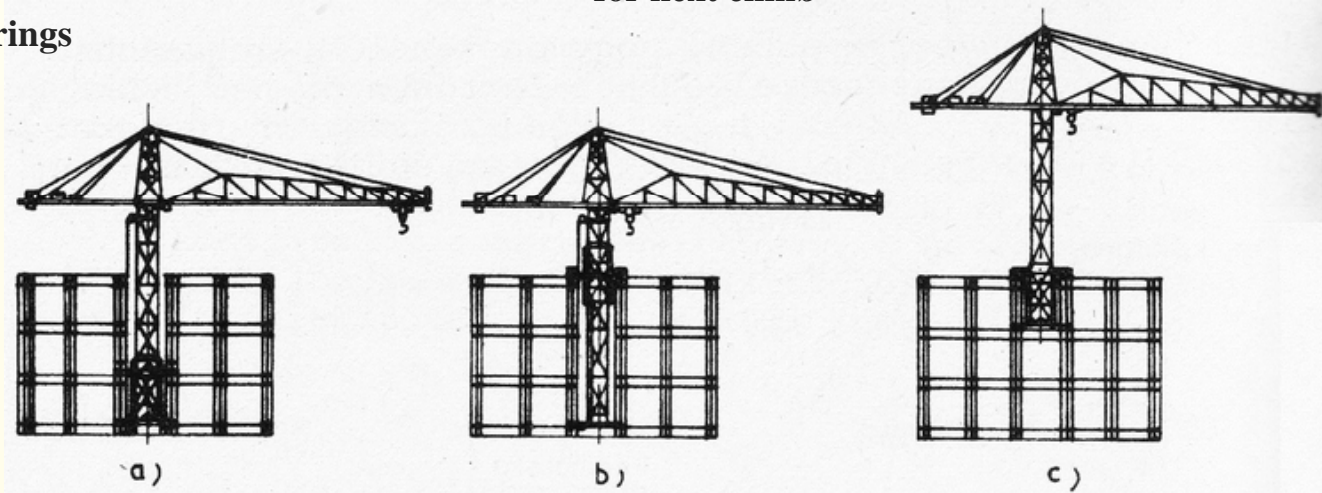

Telescopic Mast: a. start position; b. lifting bush; c. climbing and fixing

Airlift

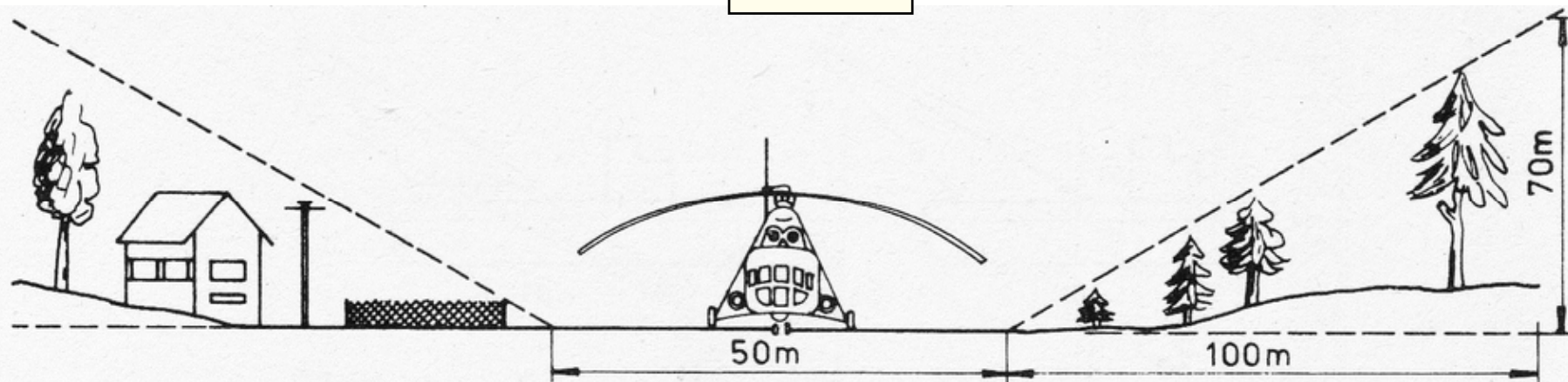

Necessary free landing (and take-off) zone

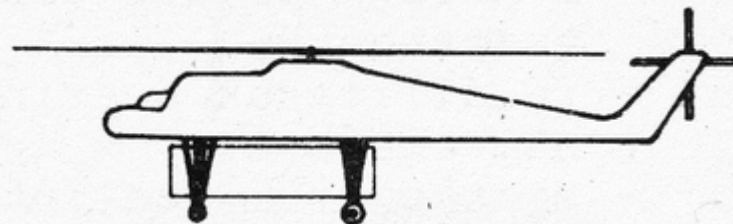
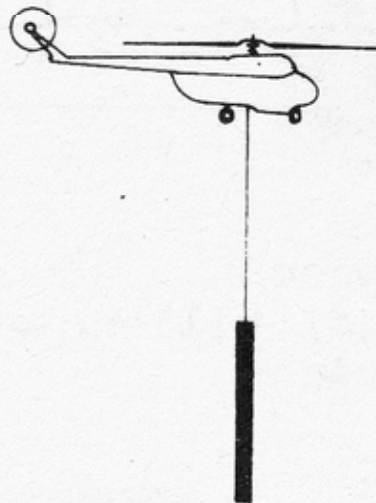
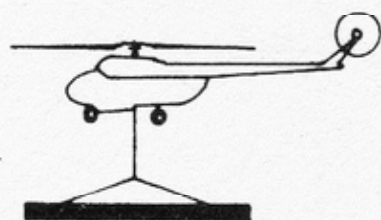

Load positions: hung on short rope, horizontally; hung on long rope, vertically; fixed to the shell body (or to legs)

**Railway
Crane**

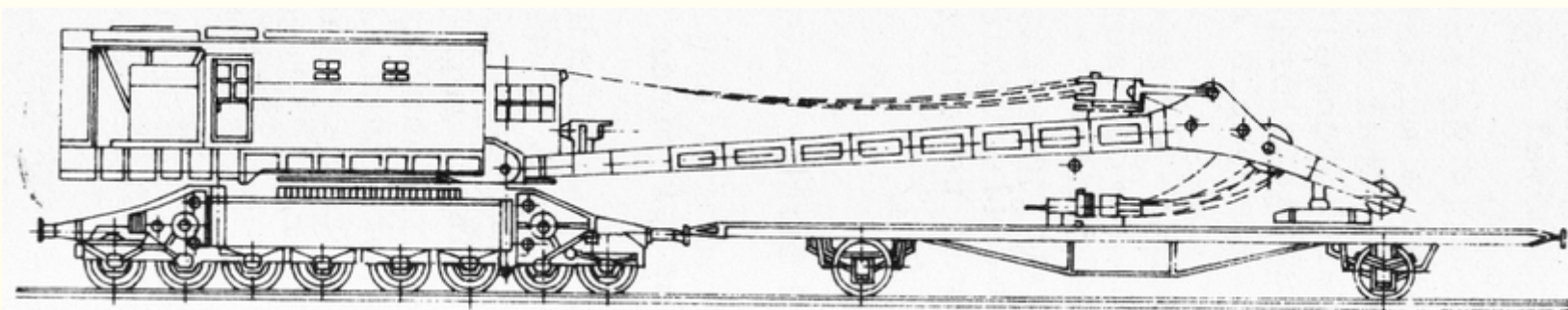
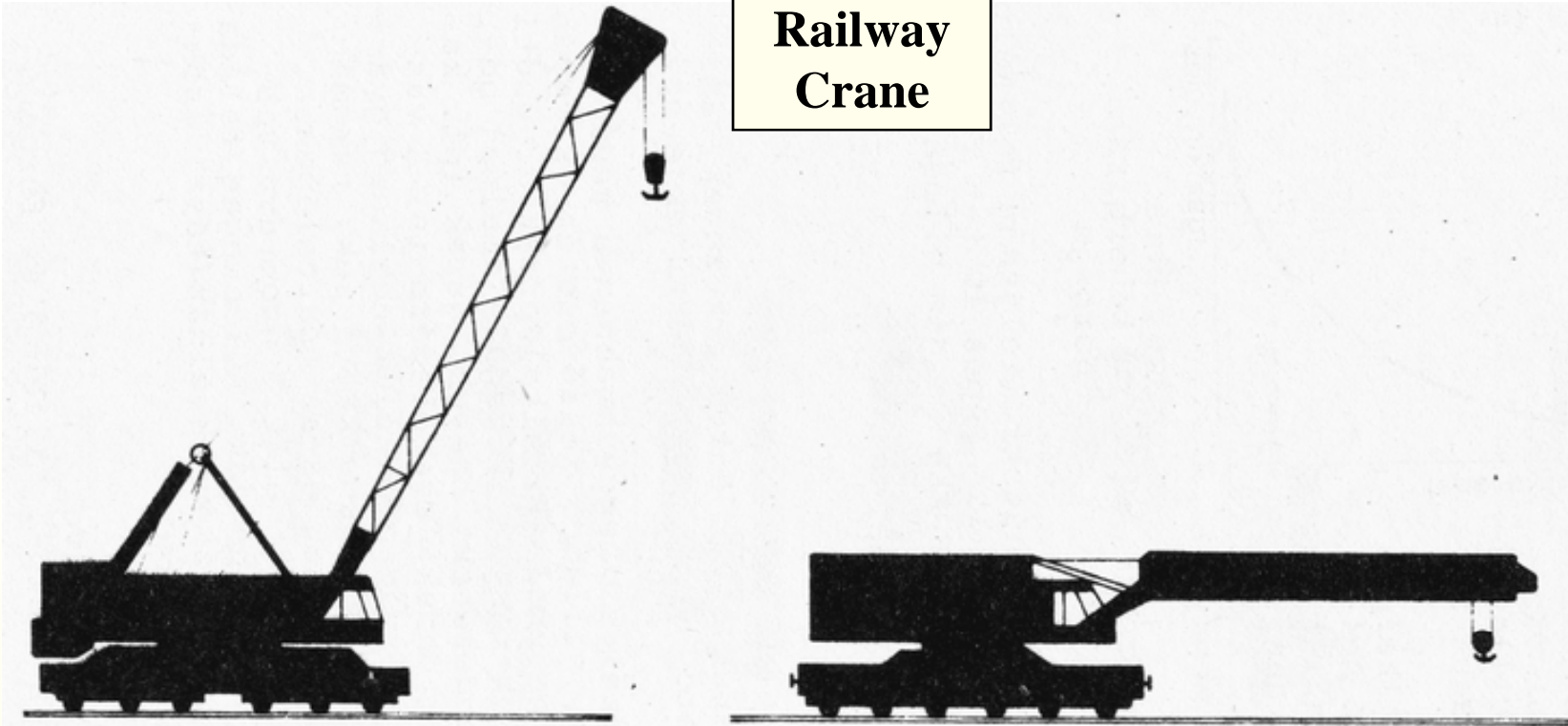

Railway crane in travelling (riding) position

Vehicle Crains

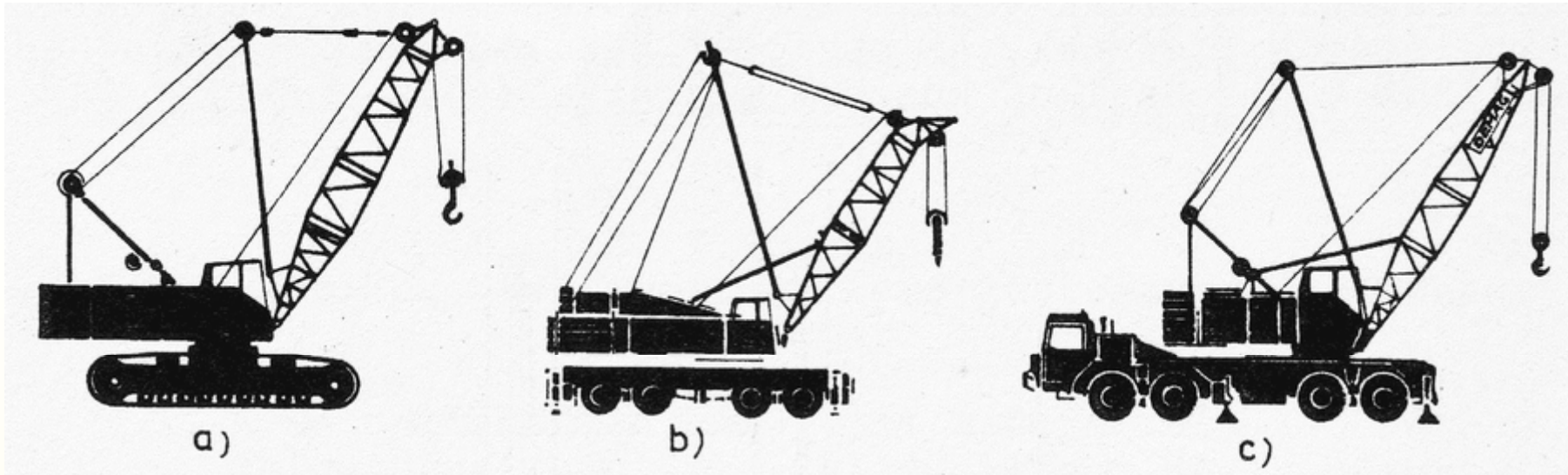

a. track mounted mobile crane;

b. wheel mounted mobile crane;

c. autocrane

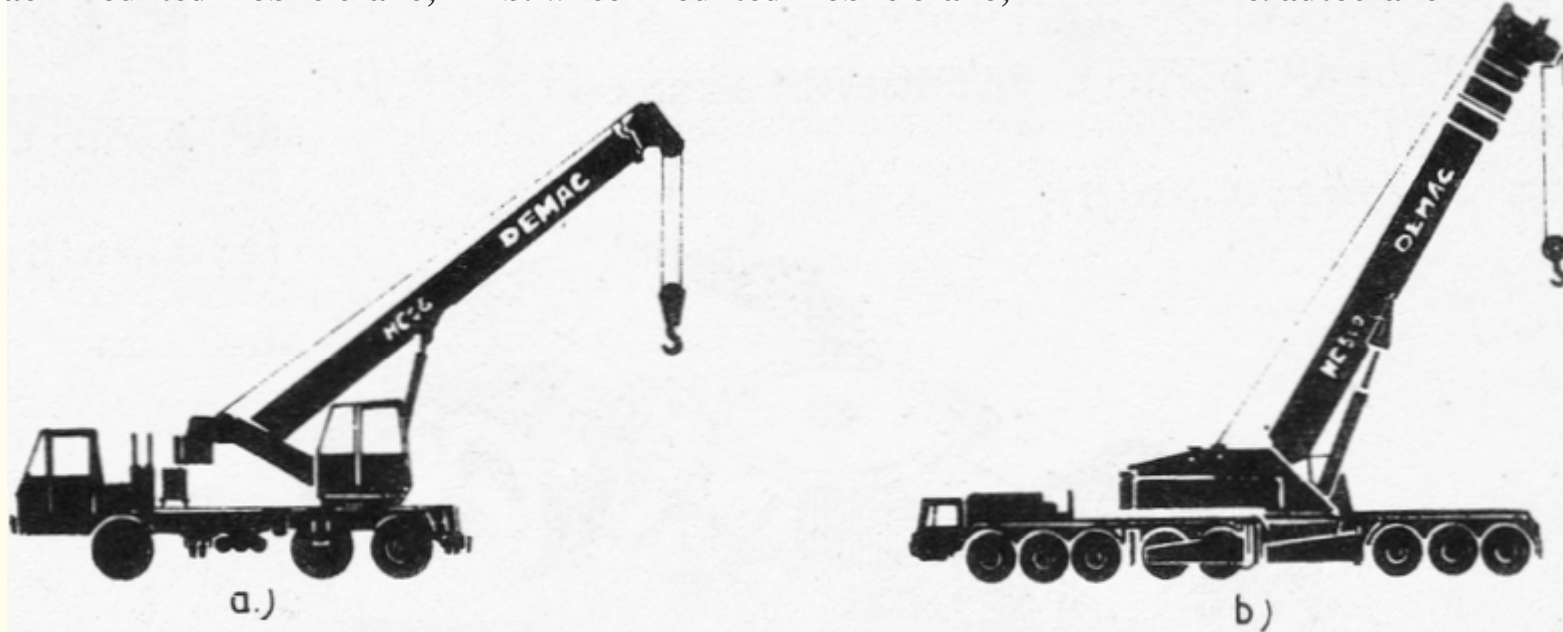

a. general truck carriage (for smaller cranes);

b. special carriage (for bigger cranes)

Lattice-boom mobile crane

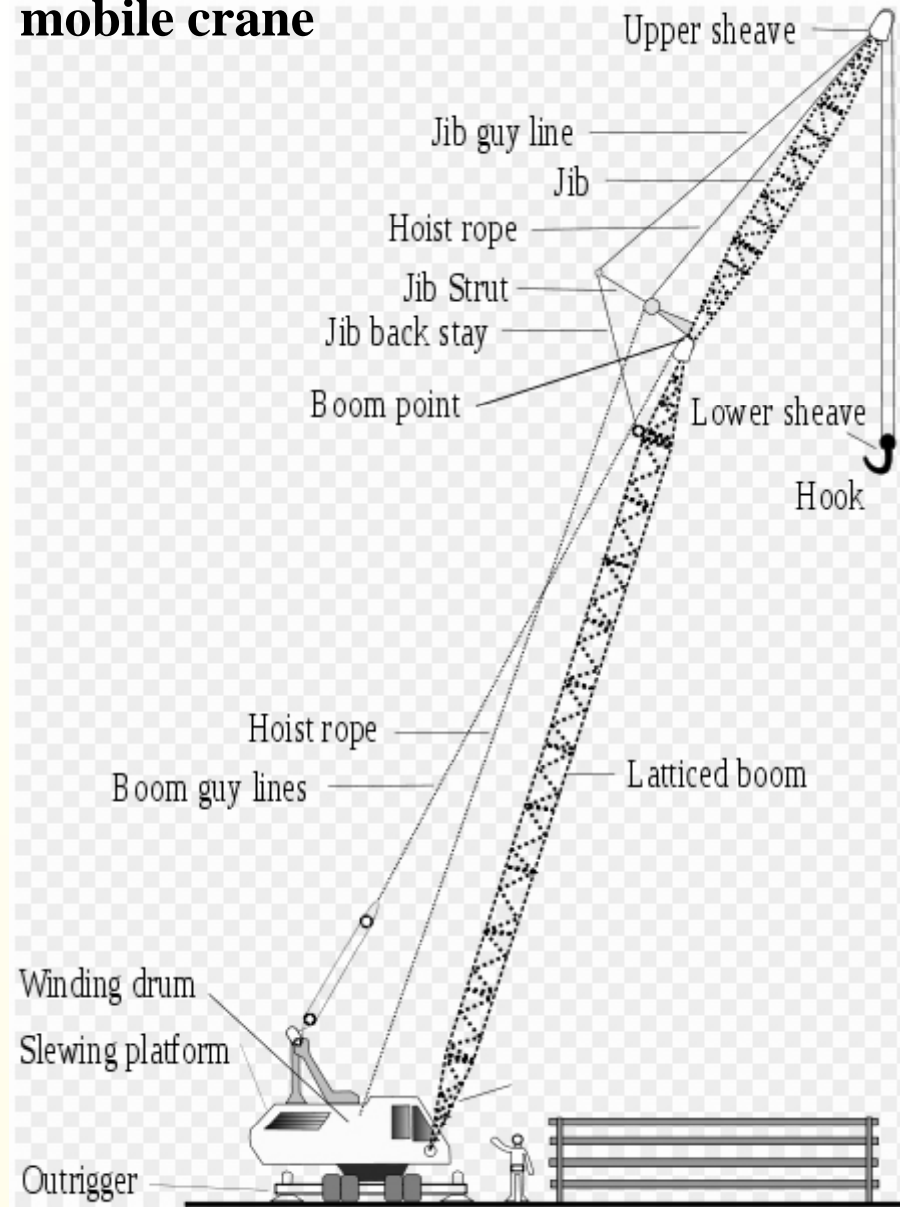

Hydraulic jack

- 1. cylinder; 2. piston (pump);
- 3. camshaft; 4. delivery valve;
- 5. admission valve

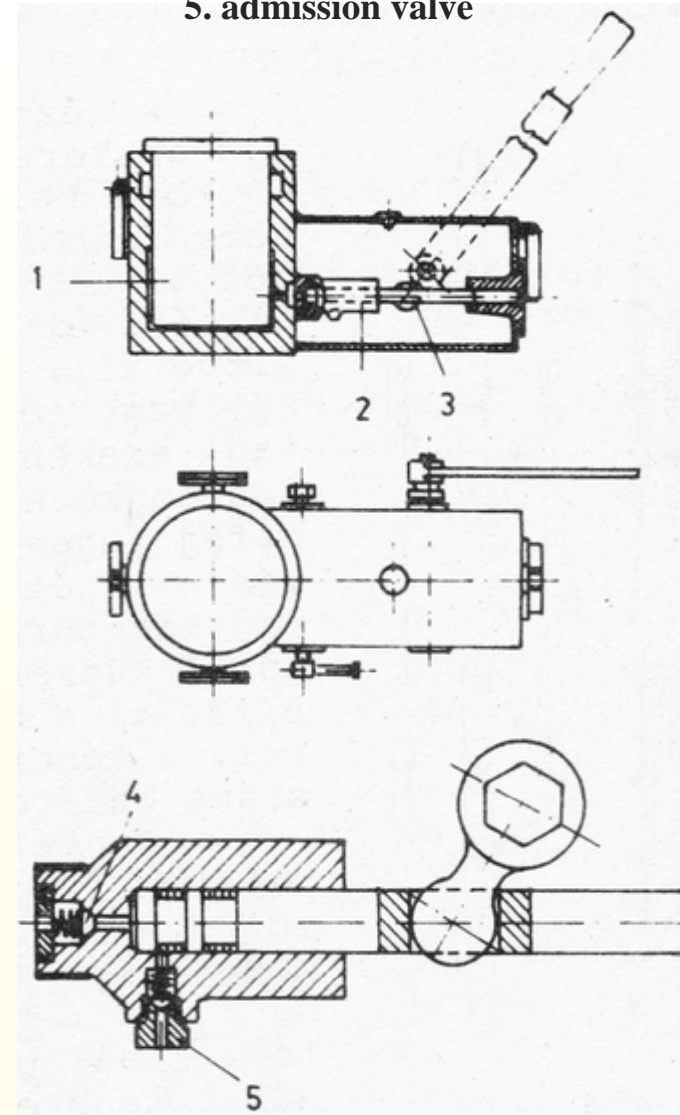

Ratchet jack

**Screw jack
(tripod jack)**

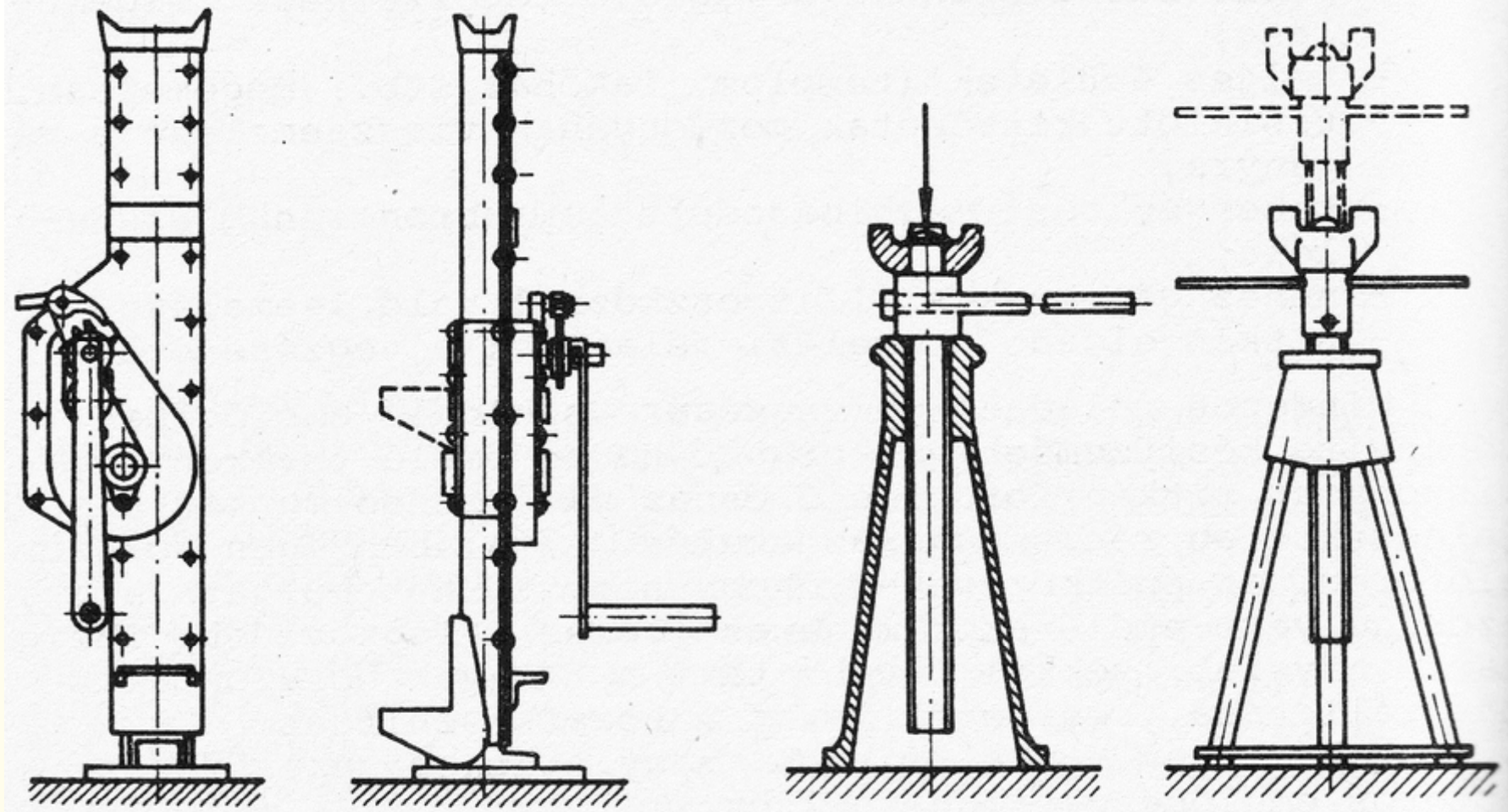

Crawler Crains

Typical at deep foundation works

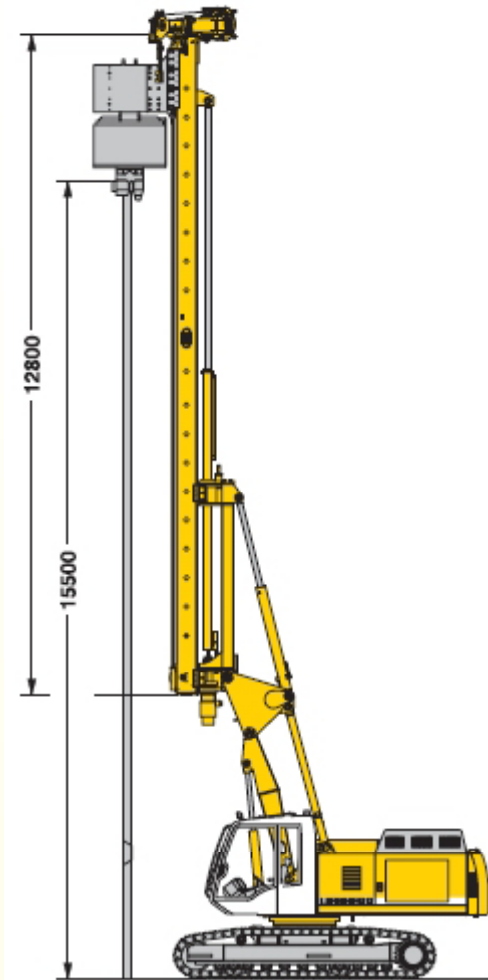

Drilling

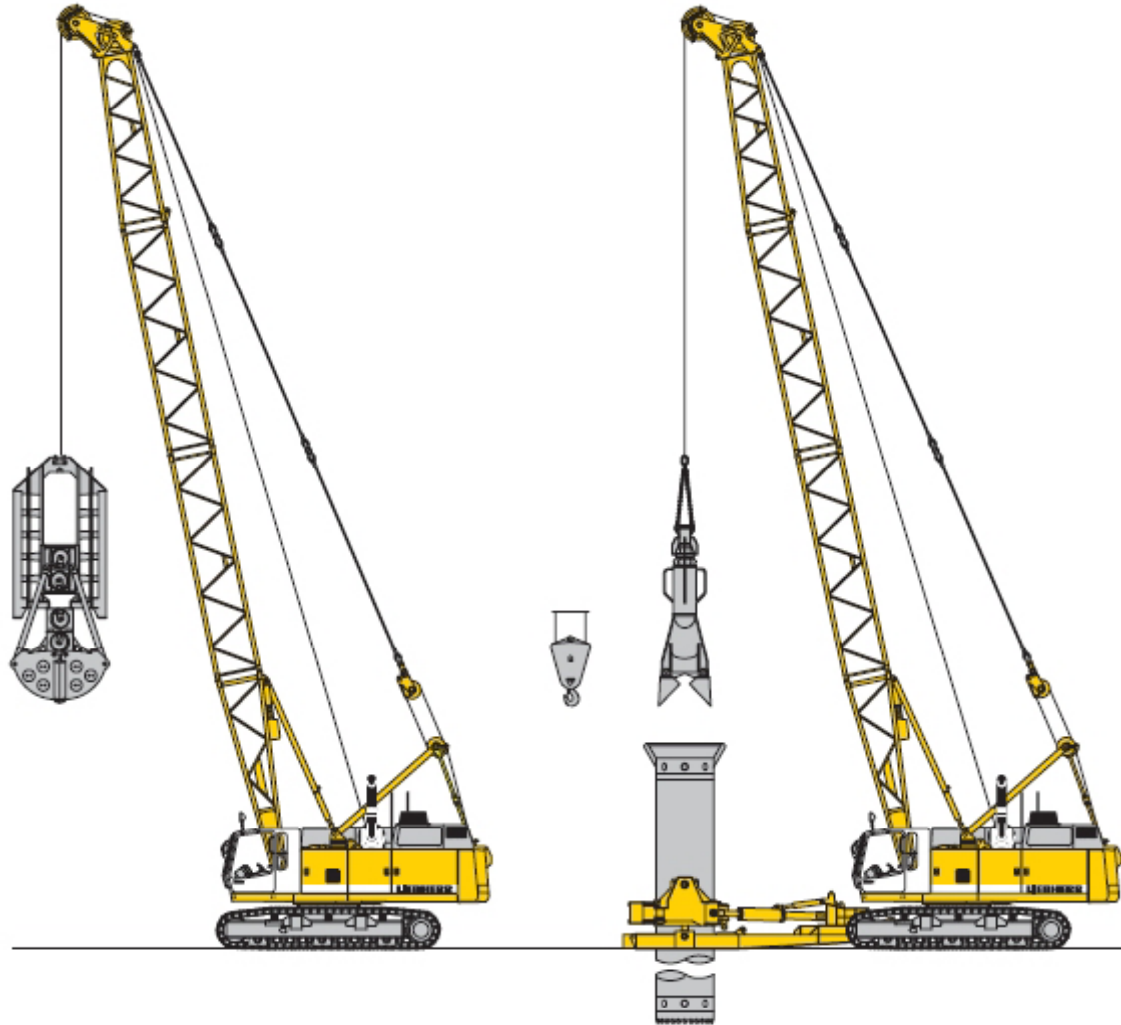

Slurry-wall excavation

Pile boring

Crawler Crains

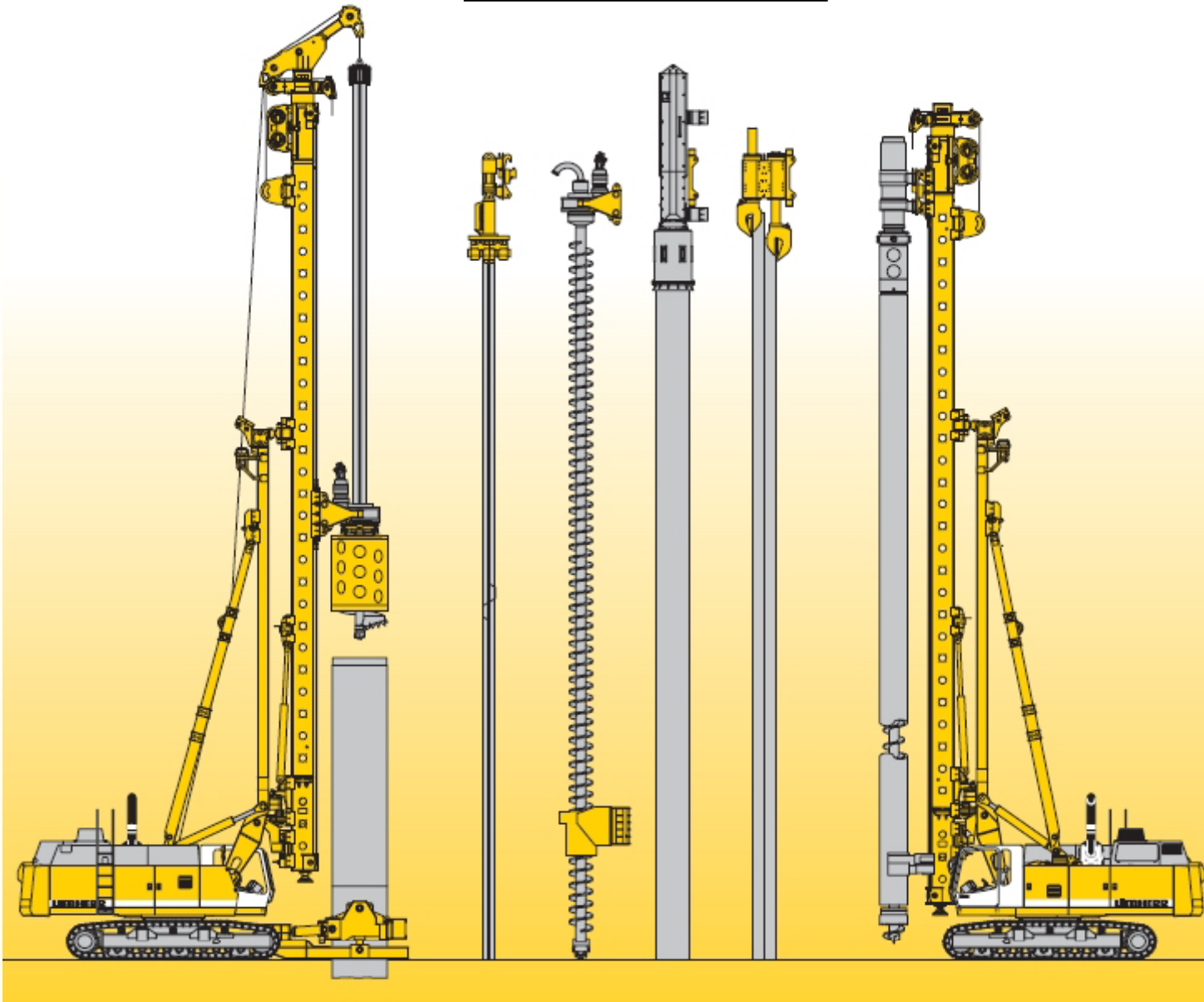

Deep inside below (deep foundations, explorations)

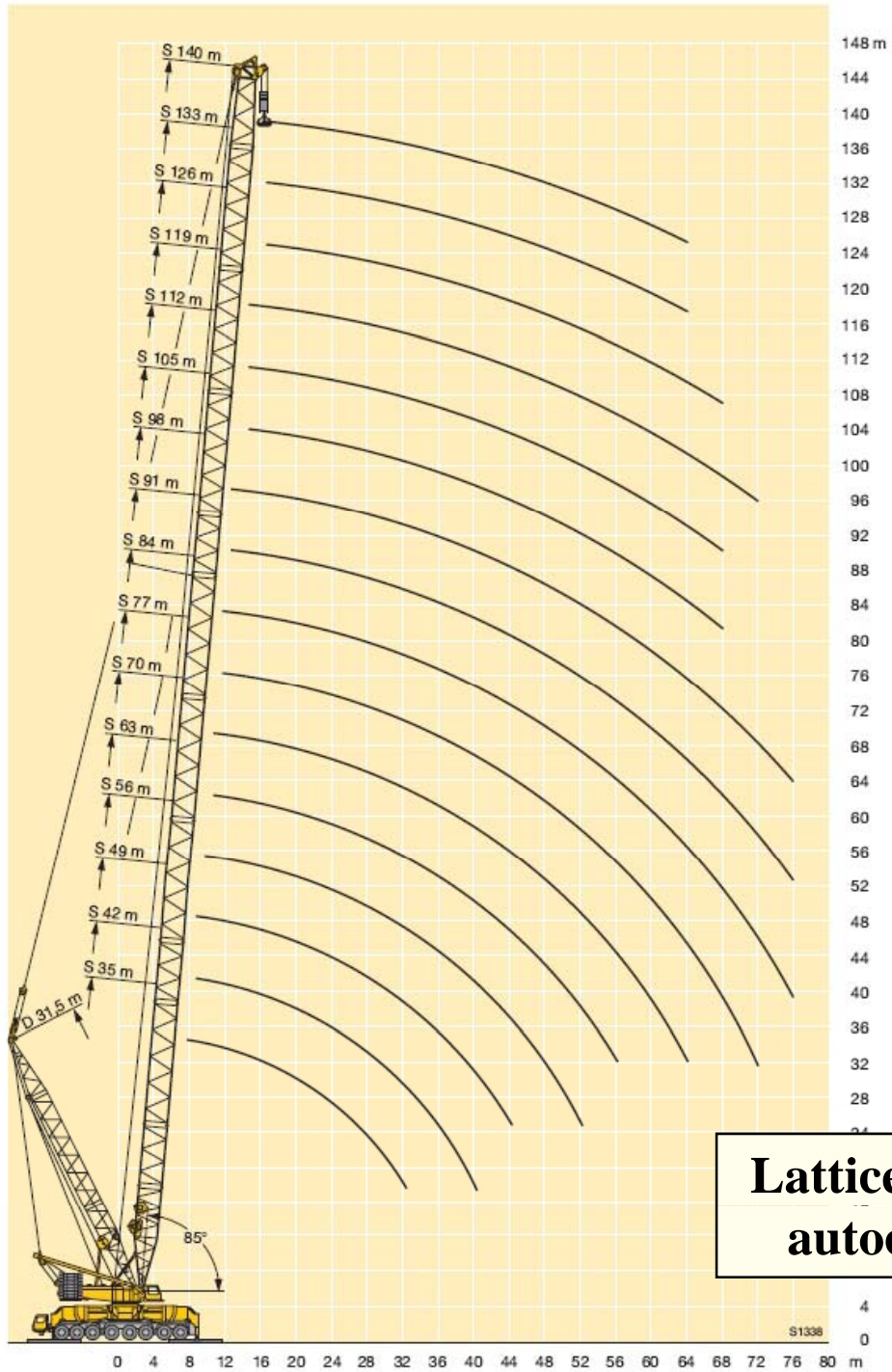

**Lattice-boom
autocrane**

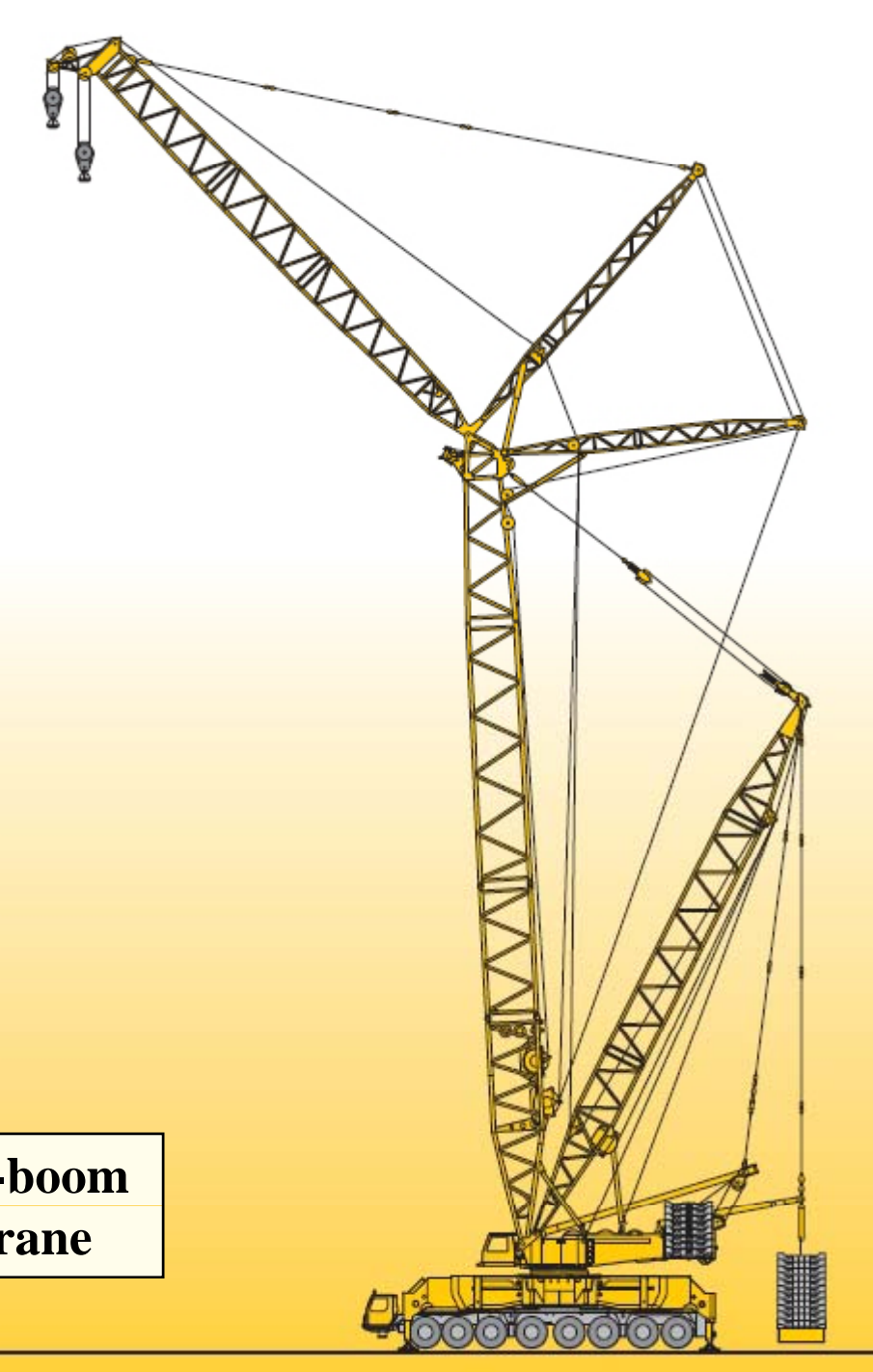

Telescopic-boom autocrane

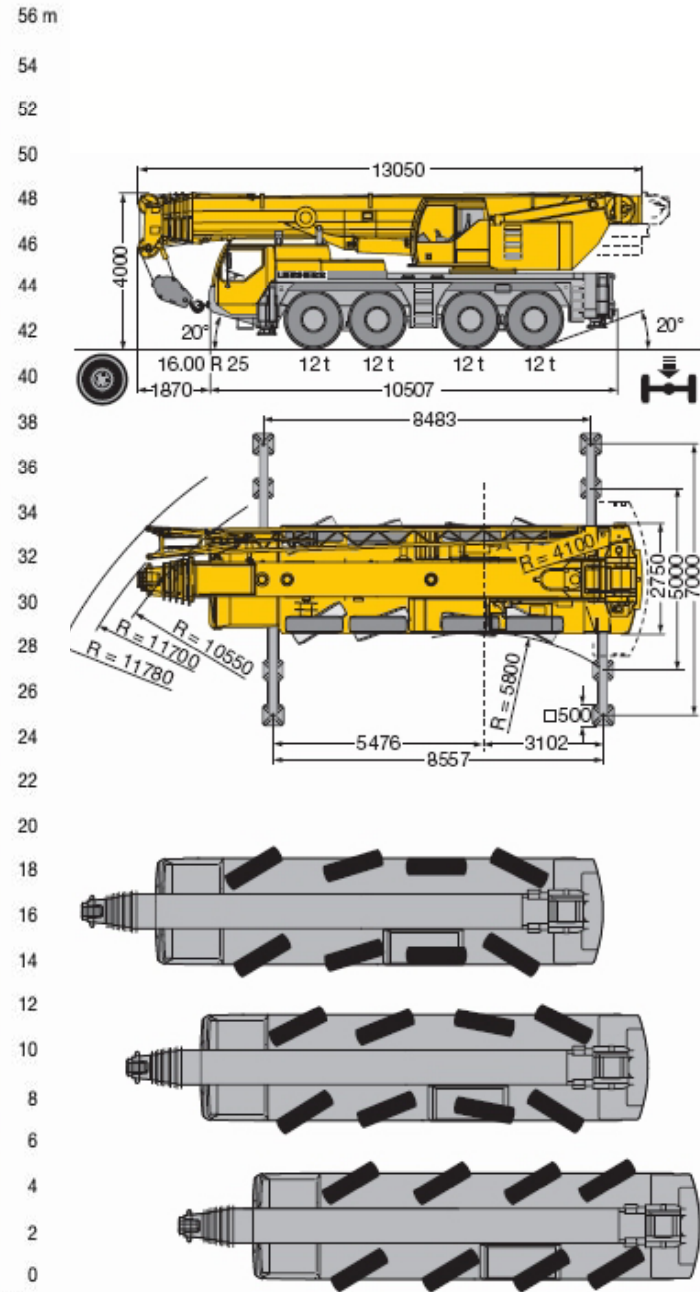
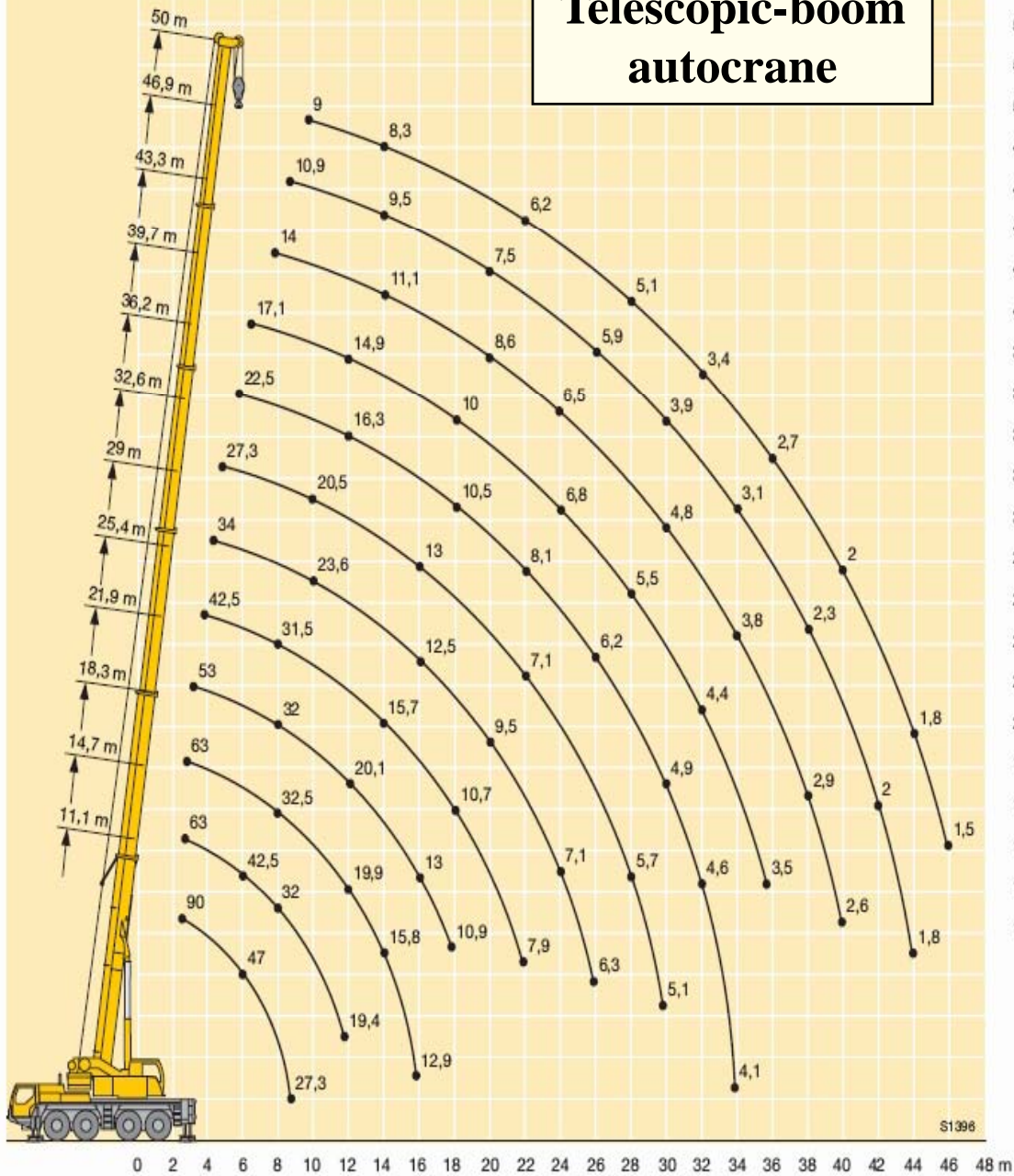

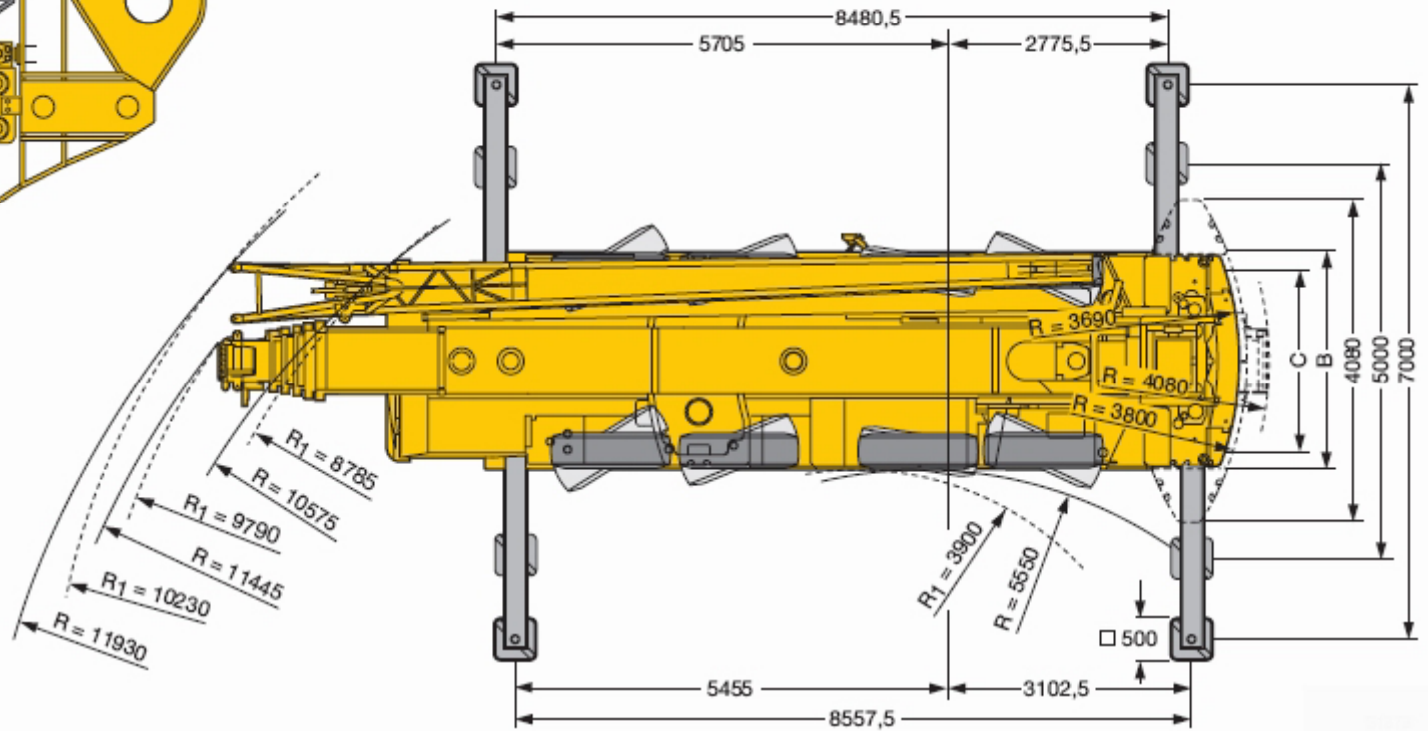
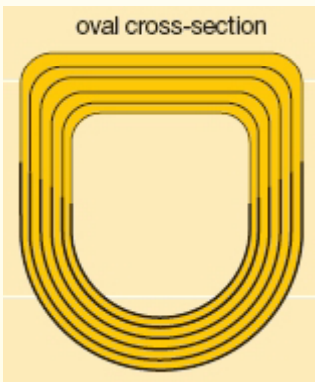
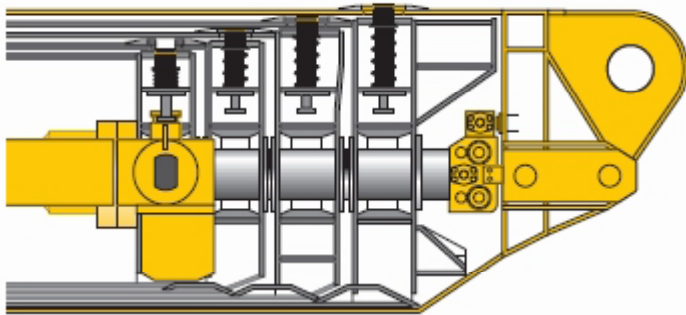
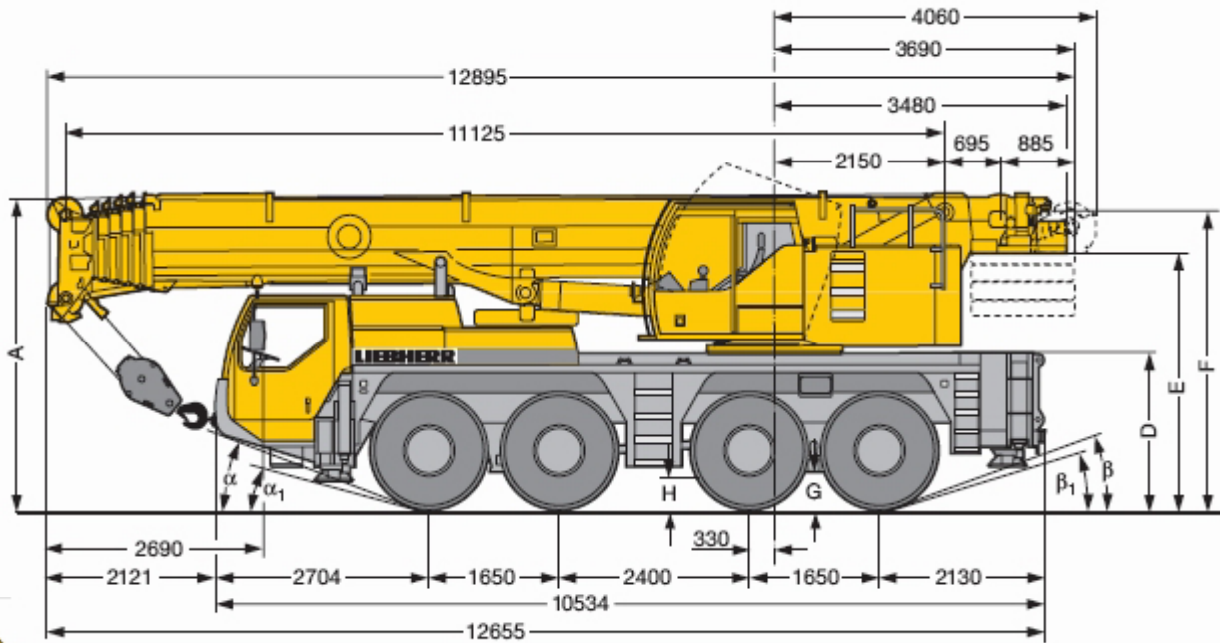
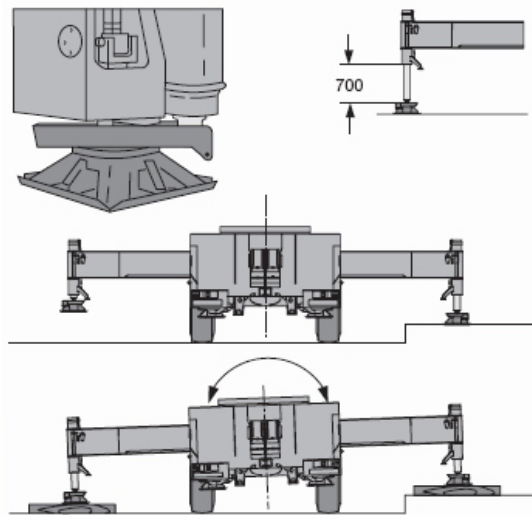

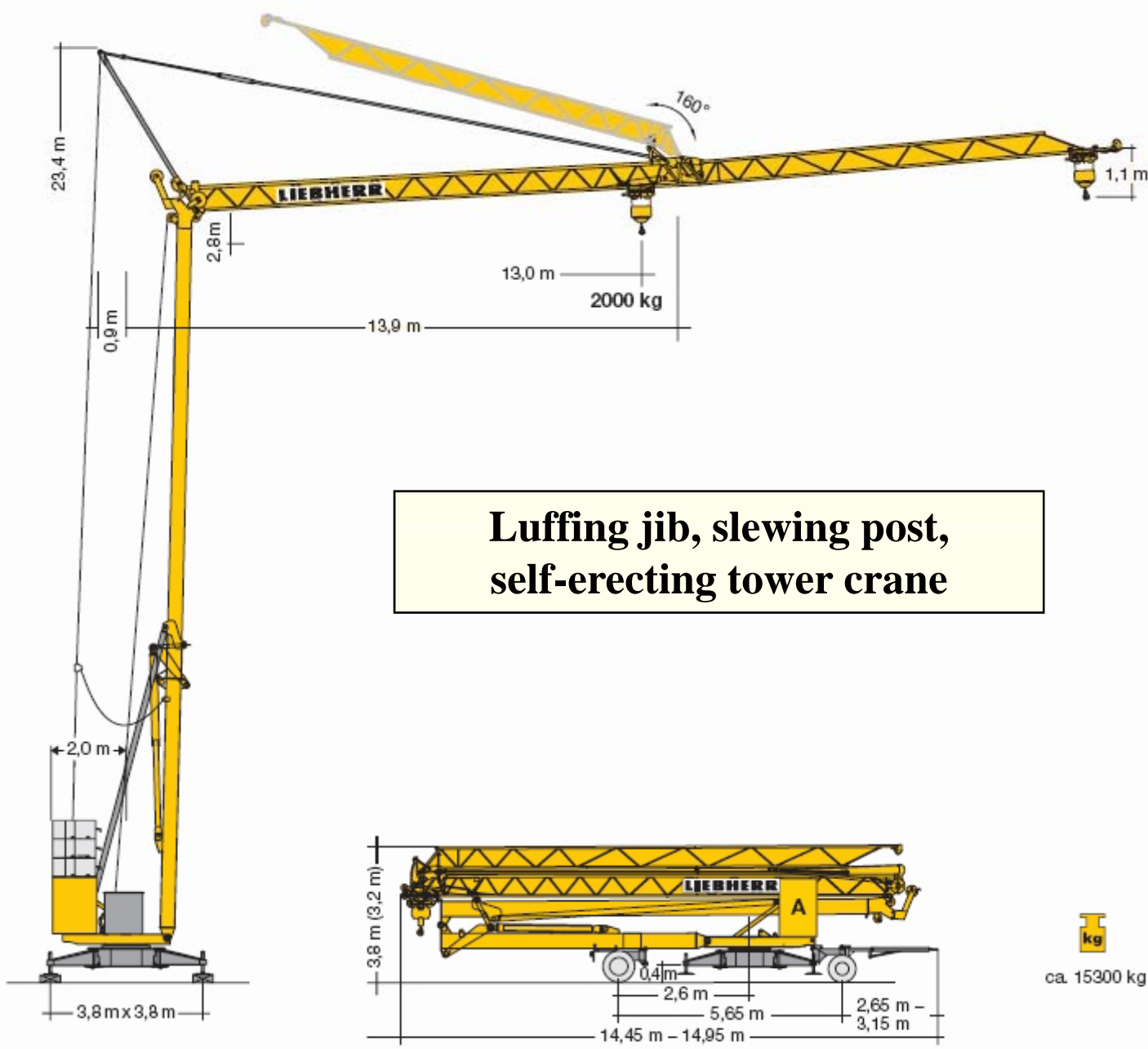

Luffing jib, slewing post, self-erecting tower crane

Luffing jib with crab, slewing post, track mounted, self-erecting tower crane

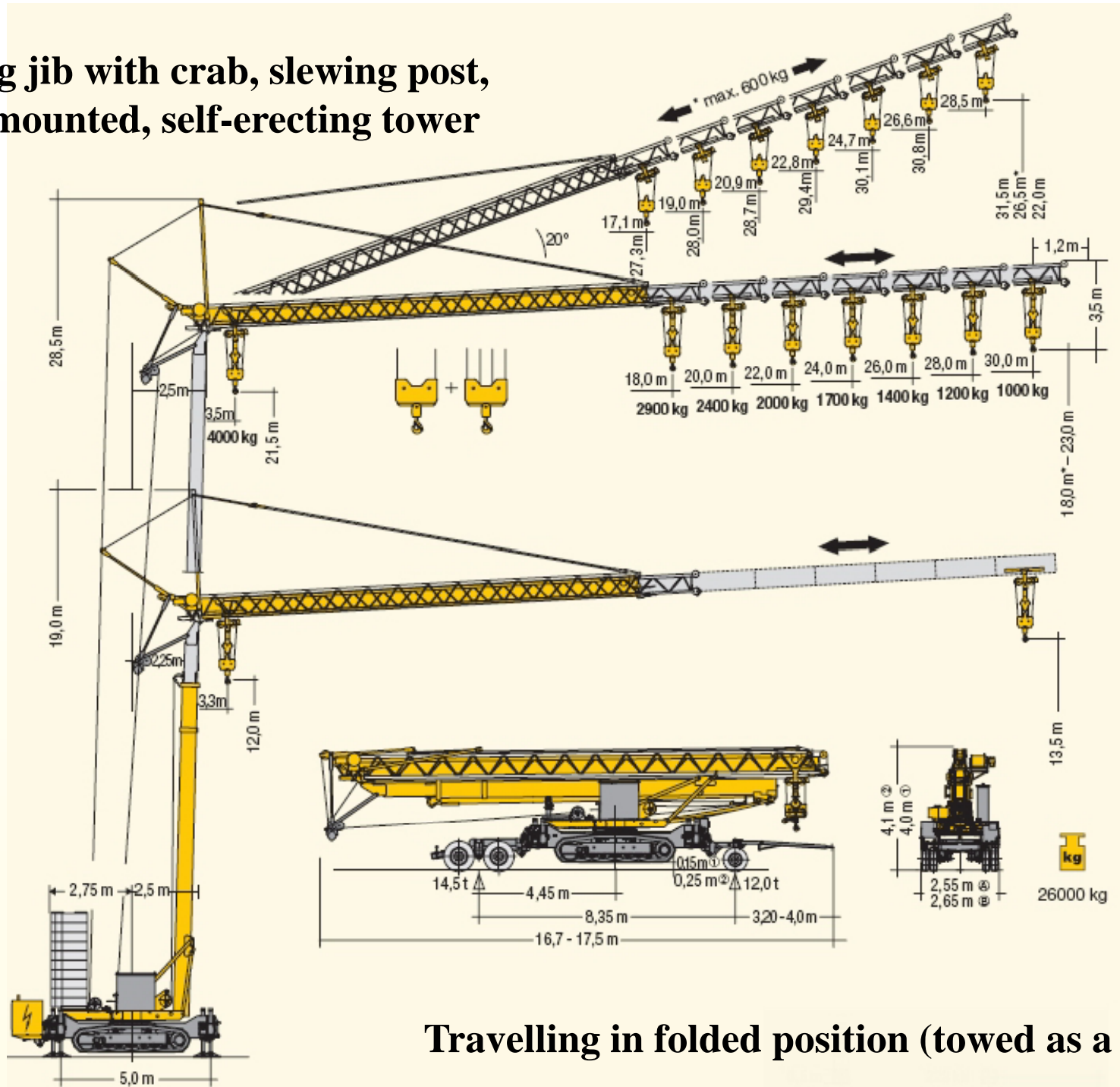

Travelling in folded position (towed as a trailer)

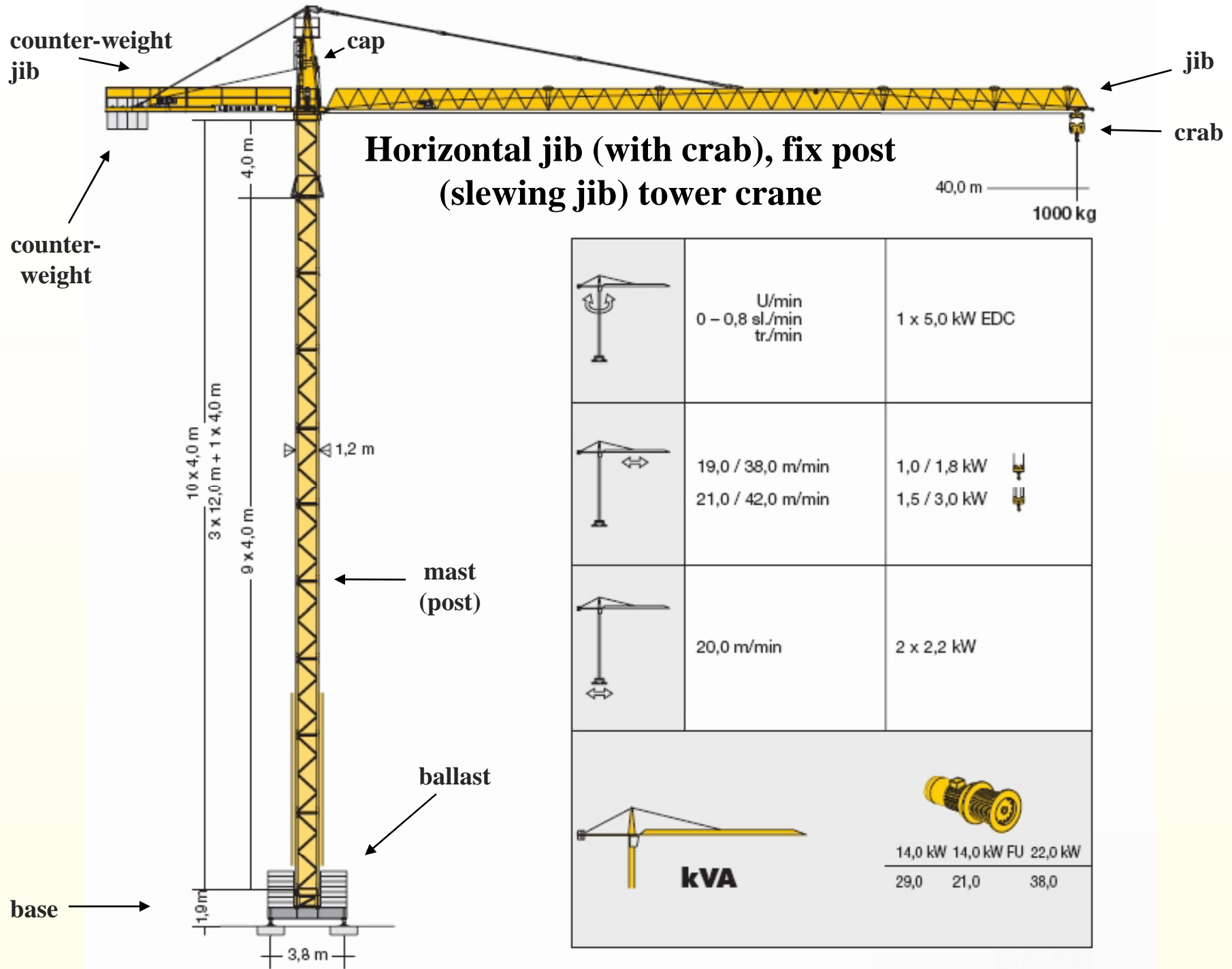

Horizontal jib (with crab), fix post (slewing jib) tower crane

	U/min 0 - 0,8 sl./min tr./min	1 x 5,0 kW EDC
	19,0 / 38,0 m/min 21,0 / 42,0 m/min	1,0 / 1,8 kW 1,5 / 3,0 kW
	20,0 m/min	2 x 2,2 kW
 kVA		 14,0 kW 14,0 kW FU 22,0 kW 29,0 21,0 38,0

Hook casing, sheave block

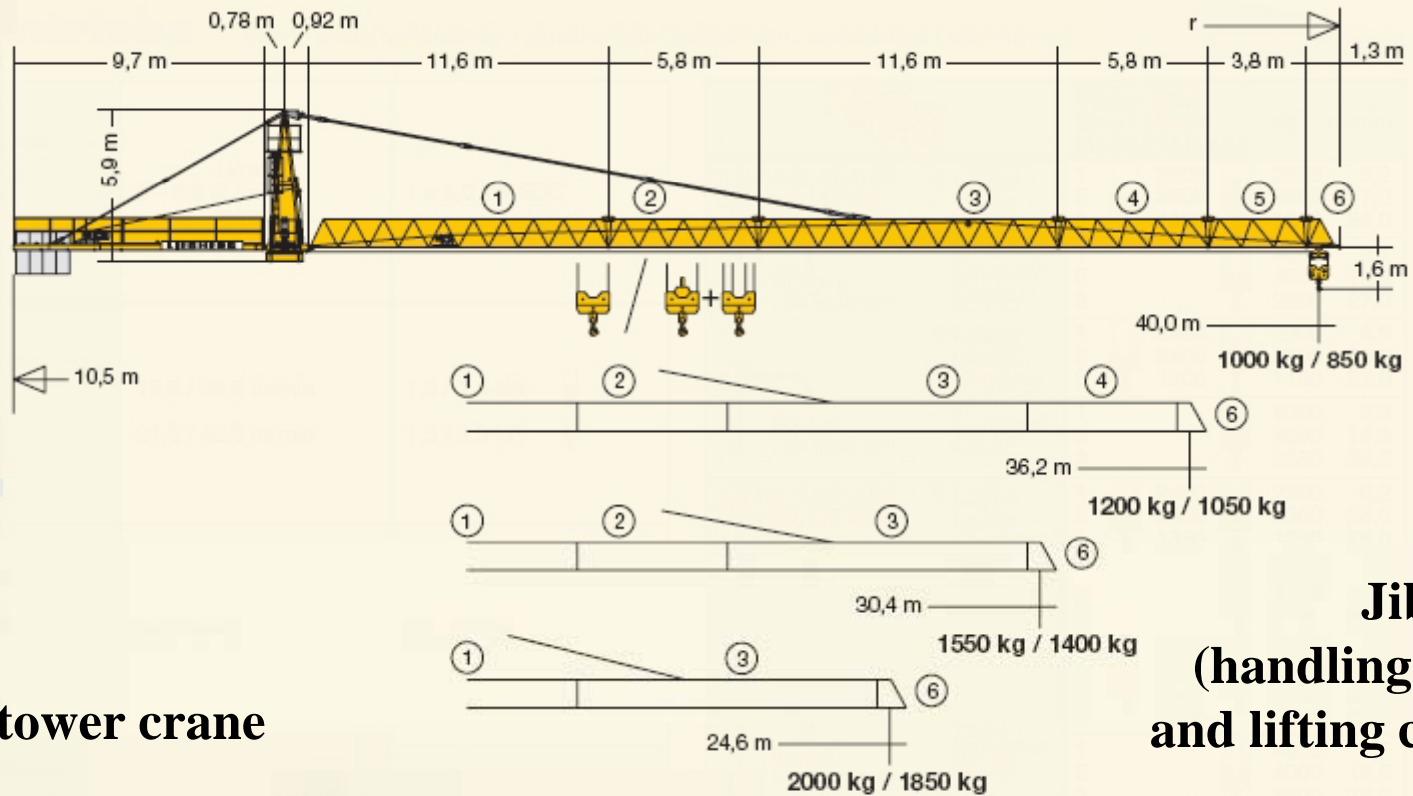
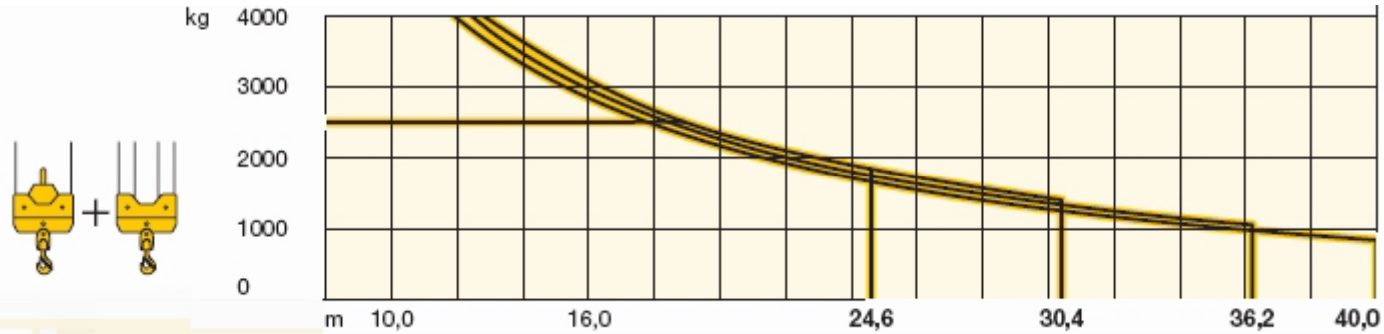

**Jib length
(handling radius)
and lifting capacity**

Fix-post tower crane footings

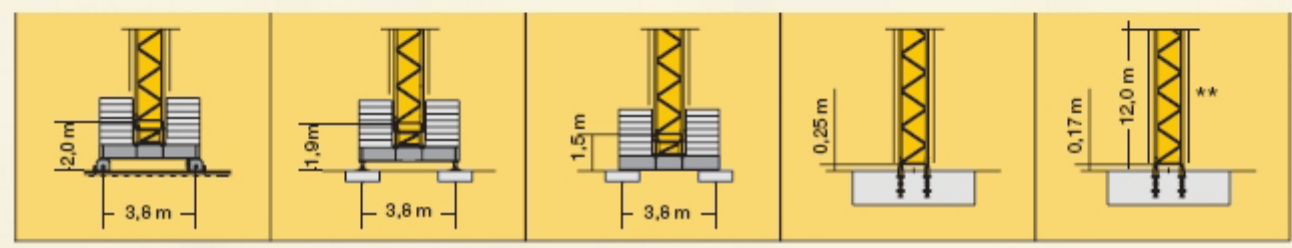

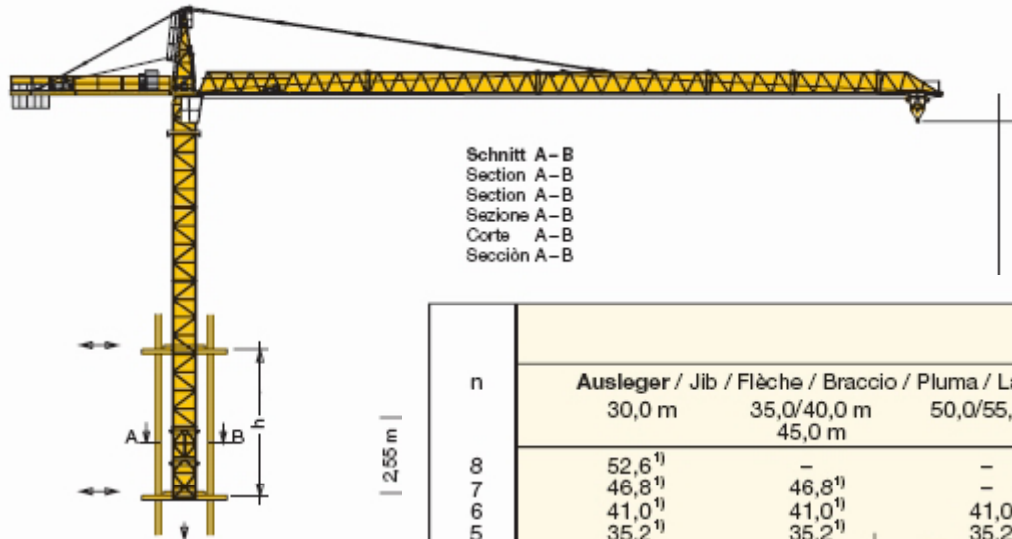

Schnitt A-B
 Section A-B
 Section A-B
 Sezione A-B
 Corte A-B
 Sección A-B

Climbing crane

		256 IC							
n	Ausleger / Jib / Flèche / Braccio / Pluma / Lança	30,0 m	35,0/40,0 m 45,0 m	50,0/55,0 m		Ausleger / Jib / Flèche / Braccio / Pluma / Lança	30,0 m	35,0/40,0 m 45,0 m	50,0/55,0 m
8	52,6 ¹⁾	-	-	-	nx5,8m	7 ¹⁾	-	-	-
7	46,8 ¹⁾	46,8 ¹⁾	-	6 ¹⁾		-	-	-	
6	41,0 ¹⁾	41,0 ¹⁾	41,0 ¹⁾	5 ¹⁾		5 ¹⁾	5 ¹⁾	5 ¹⁾	
5	35,2 ¹⁾	35,2 ¹⁾	35,2 ¹⁾	4 ¹⁾		4 ¹⁾	4 ¹⁾	4 ¹⁾	

		256 HC								
n	Ausleger / Jib / Flèche / Braccio / Pluma / Lança	30,0/35,0 m	40,0/45,0 m 50,0 m	55,0 m		Ausleger / Jib / Flèche / Braccio / Pluma / Lança	30,0/35,0 m	40,0/45,0 m	50,0 m	55,0 m
8	38,7 ¹⁾	-	-	-	nx4,14m	6 ¹⁾	-	-	-	
7	34,6 ¹⁾	34,6 ¹⁾	-	5 ¹⁾		5 ²⁾	-	-		
6	30,5 ¹⁾	30,5 ¹⁾	30,5 ¹⁾	4 ¹⁾		4 ¹⁾	4 ¹⁾	4 ¹⁾		

Fix-post (mast) tower crane

Flat-top (with no cap), horizontal slewing jib (with crab) fix-post tower crane

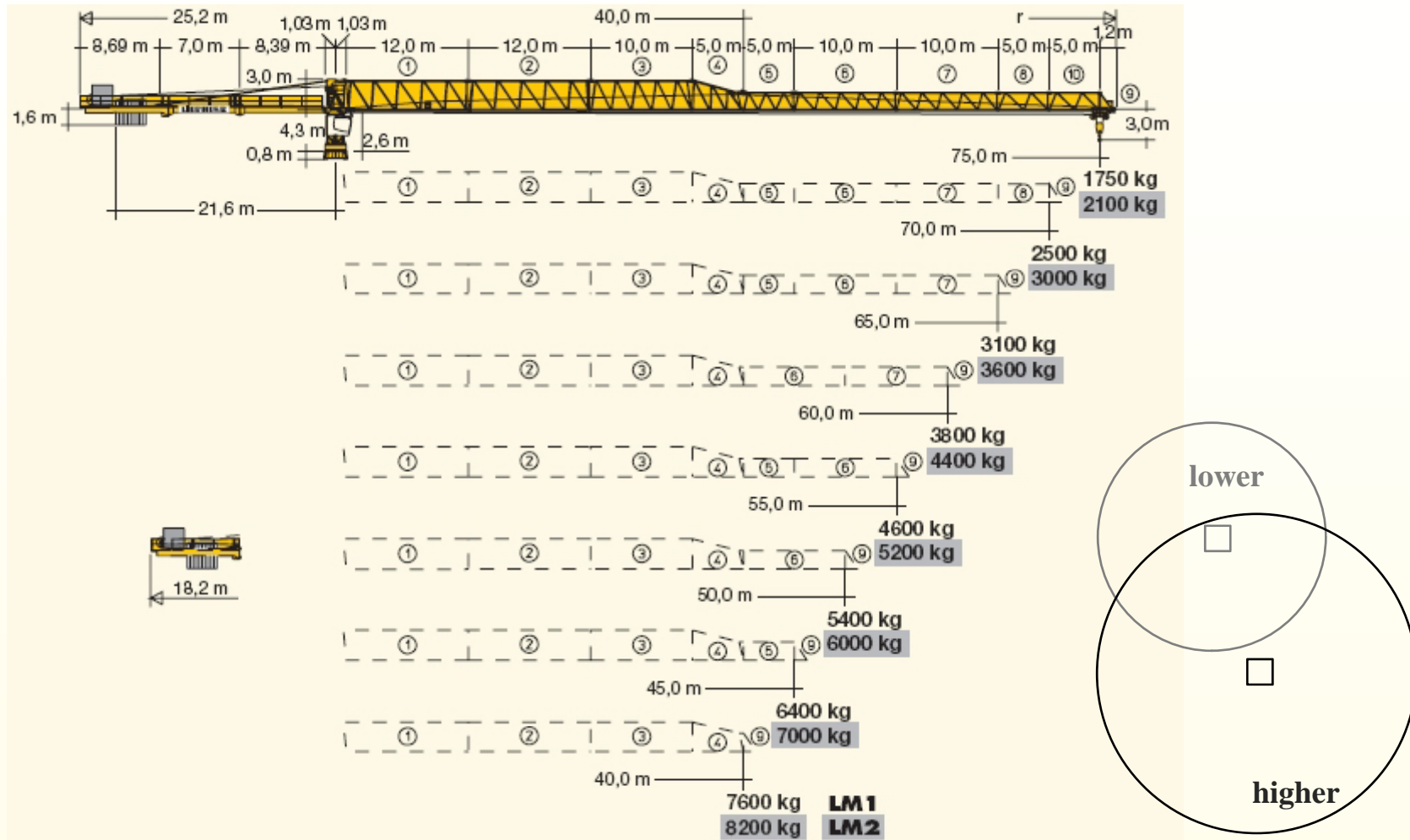

**Typical where more tower cranes have to co-operate within reach
(as the lower crane – the higher can mount and dismantle the lower one)**

Horizontal slewing jib, fix post, tower crane

Not the smallest one
(Consider its sizes!)

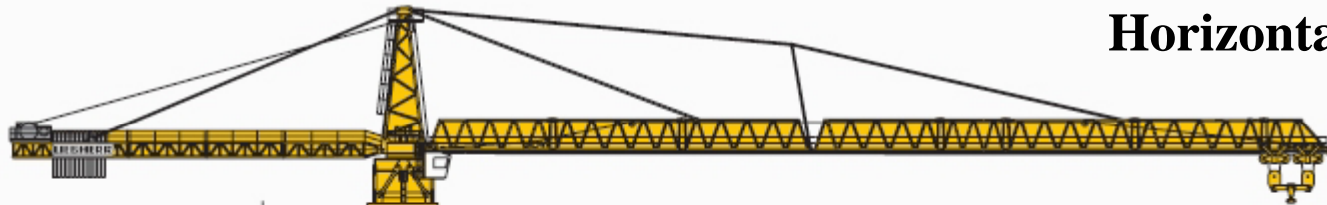

80,0 m

32000 kg

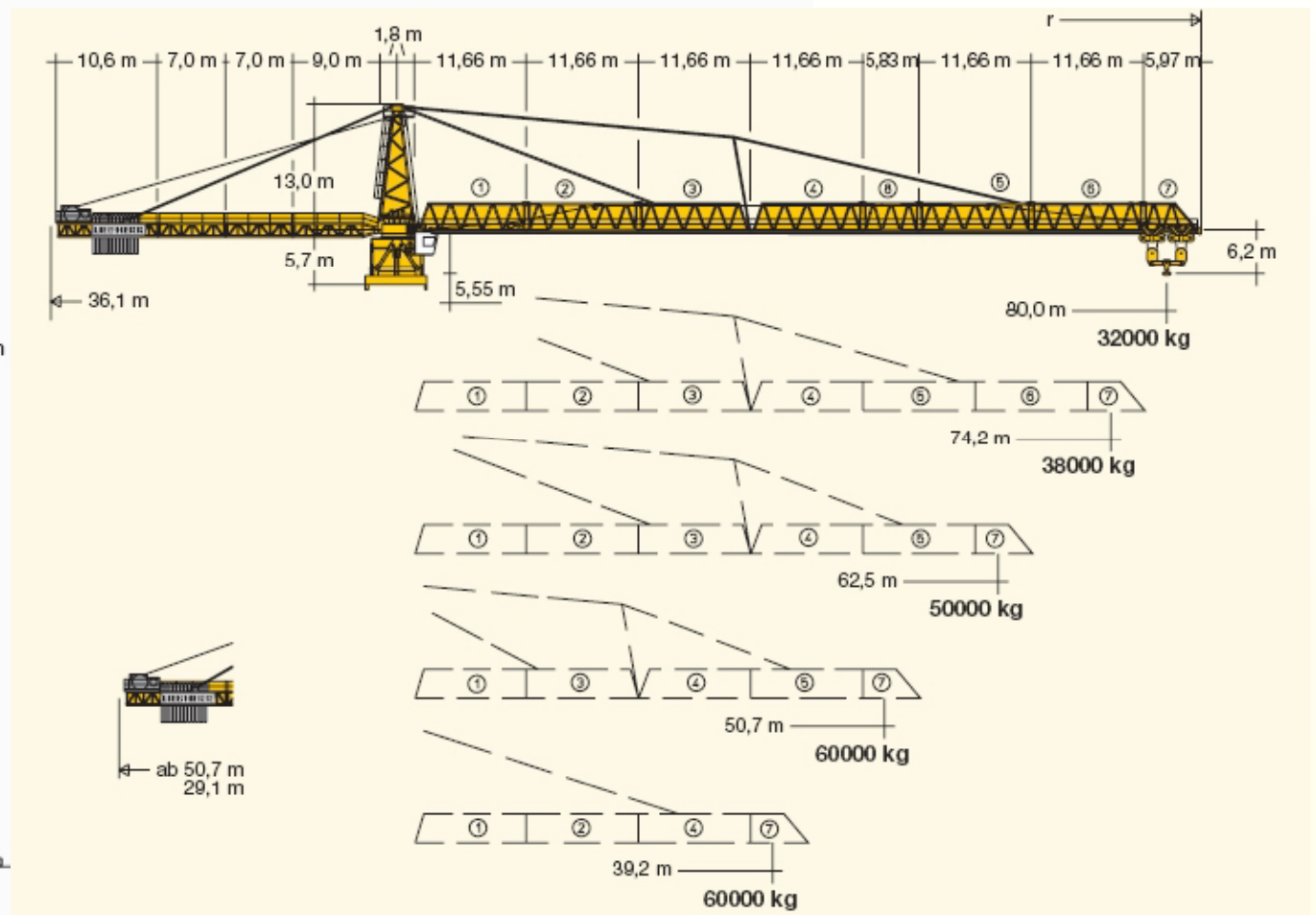
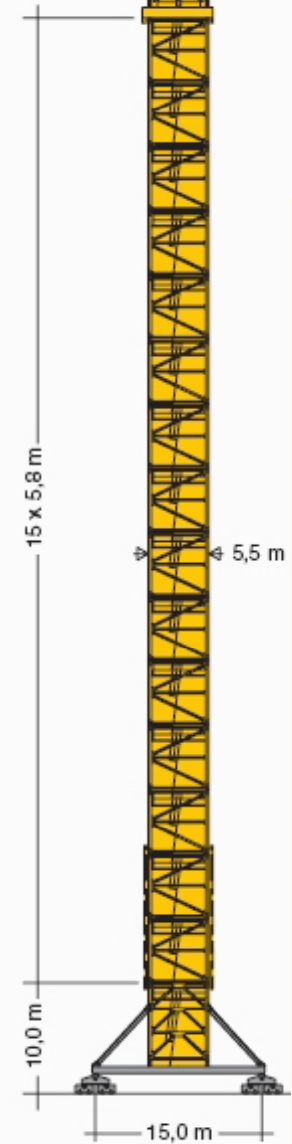
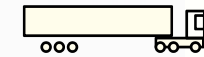

The compact tower head. EC-B Flat-Top tower cranes.

New technology. New ideas.

Complete unit including:

Cabin, slewing gears, switchgear, slewing ring support, slewing ring, guy frame and current collector

Retractable deluxe cabin

Folding guy frame

Compact tower head.

- Transport in upright position possible
- Completely pre-assembled
- A single transport unit
- Erection in a single lift
- Plug-in connections for the entire electrical installation
- Slewing possible immediately after erection
- Only one switch cabinet including S1 and S2
- Folding guy frame for low transport height
- Interchangeable deluxe cabin
 - can be removed
 - can be retracted for transport



Switch cabinet including S1 and S2

LIEBHERR

Basic Standard Hand Signals for Cranes and Hoisting Equipment



HOIST: With forearm vertical, and forefinger pointing up, move hand in small horizontal circle.



LOWER: With arm extended downward, forefinger pointing down, move hand in a small horizontal circle.



RAISE BOOM: Arm extended, fingers closed, thumb pointing upward.



LOWER BOOM: Arm extended, fingers closed, thumb pointing downward.



EXTEND BOOM: Both fists in front of body with thumbs pointing outward.



RETRACT BOOM: Both fists in front of body with thumbs pointing toward each other.



SWING: Arm extended, point with finger in direction of desired boom swing.



STOP DOG EVERYTHING: Clasp hands in front of body.



MOVE SLOWLY: Use one hand to give any motion signal and place the other hand motionless in front of the hand giving the signal.



TRAVEL: Arm extended forward, hand open and slightly raised, make pushing motion in direction of travel.



USE MAIN HOIST: Tap fist on head; then use regular signals.



USE WHIP LINE (AUXILIARY HOIST): Tap elbow with one hand; then use regular signals.



STOP: Arm extended, palm down, move arm back and forth horizontally.



RAISE THE BOOM AND LOWER THE LOAD: With arm extended, thumb pointing up, flex fingers in and out as long as load movement is desired.



LOWER THE BOOM AND RAISE THE LOAD: With arm extended, thumb pointing down, flex fingers in and out as long as load movement is desired.



EMERGENCY STOP: Both arms extended, palms down, move arms back and forth horizontally.

 [Basic Standard Hand Signals](#) (PDF file).

Issued: **04/08/2003**
Tag # **AP2003-M061**



Cage lift

Exterior (Contractor's) Hoist

Shaft lift

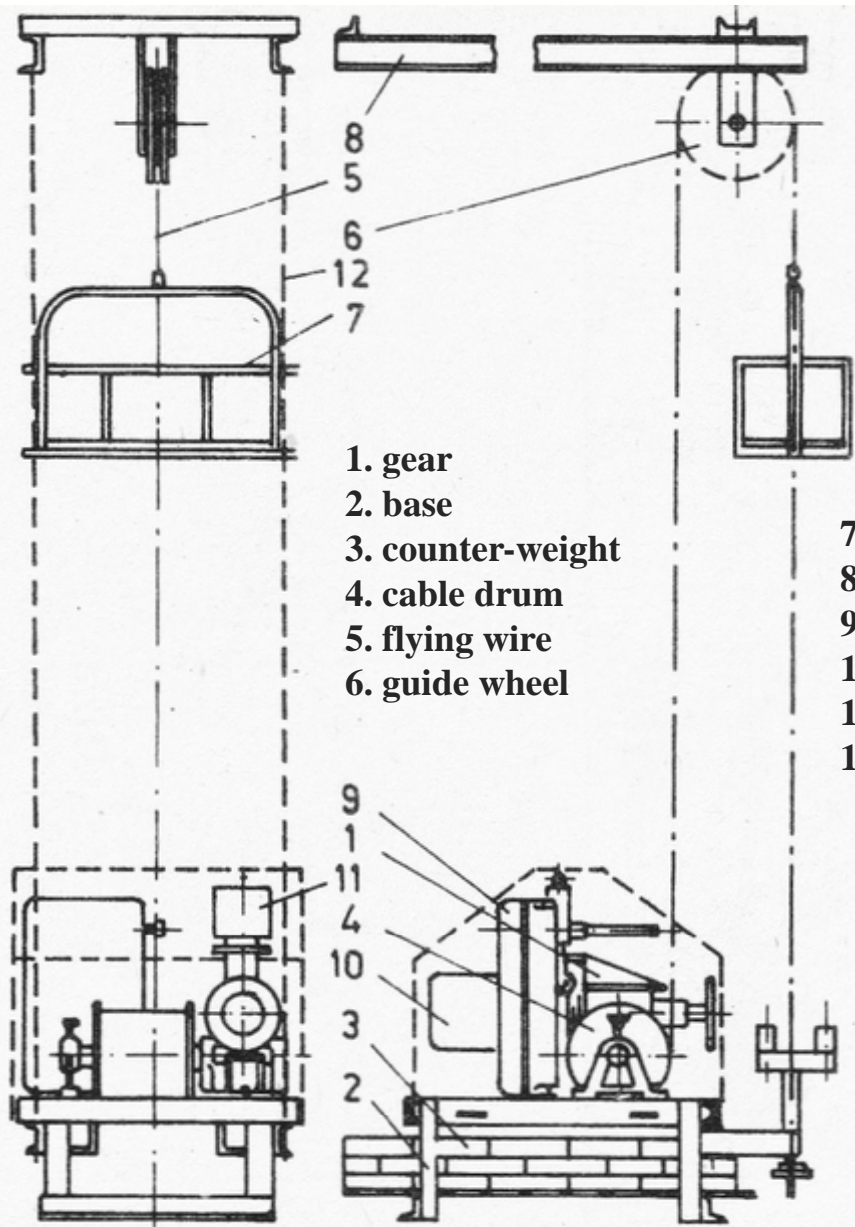

- 1. gear
- 2. base
- 3. counter-weight
- 4. cable drum
- 5. flying wire
- 6. guide wheel

- 7. lever
- 8. guide rail
- 9. control box
- 10. electromotor
- 11. break
- 12. guide rope

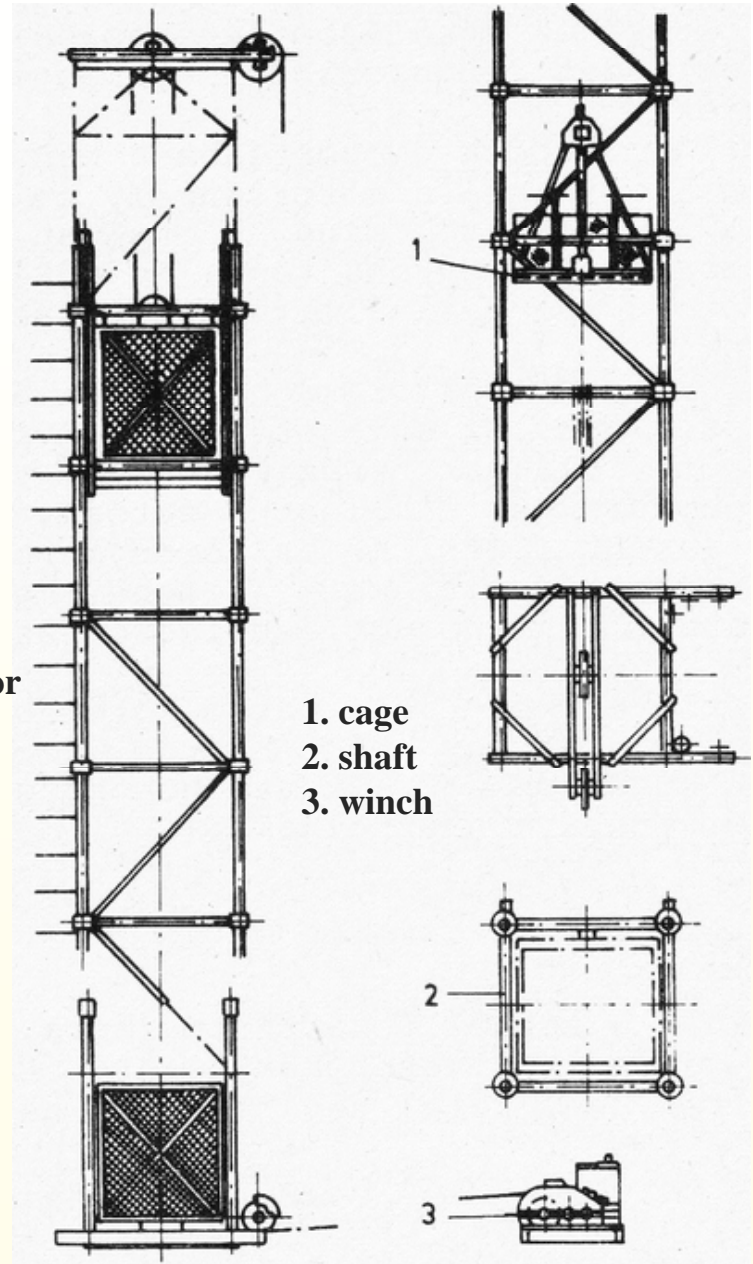

- 1. cage
- 2. shaft
- 3. winch

Elevator Tower Hoist

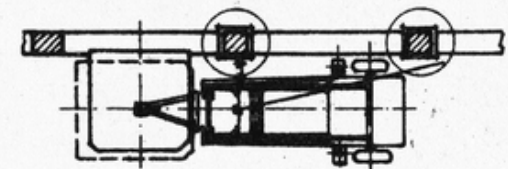
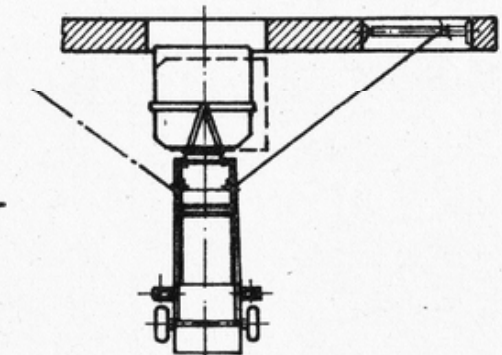
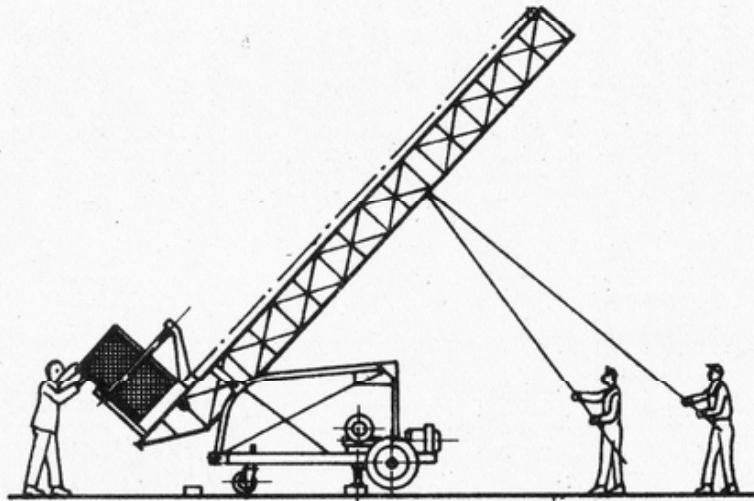
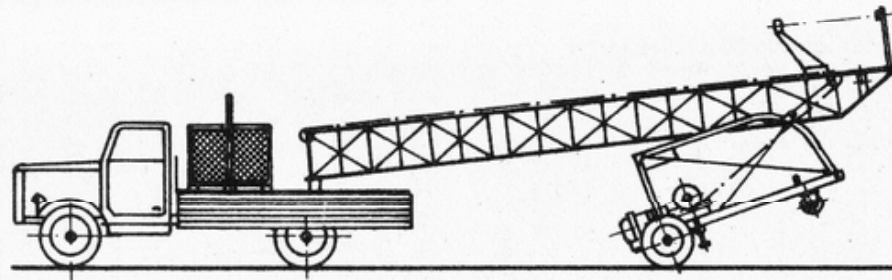
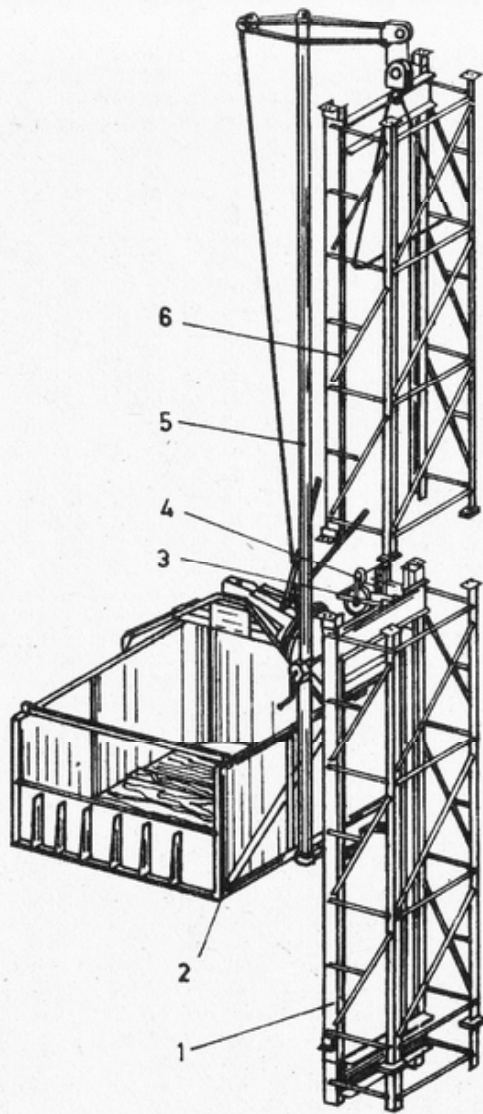

Transporting and erecting

Freight- and Passenger Lifts (Elevators/Hoists)

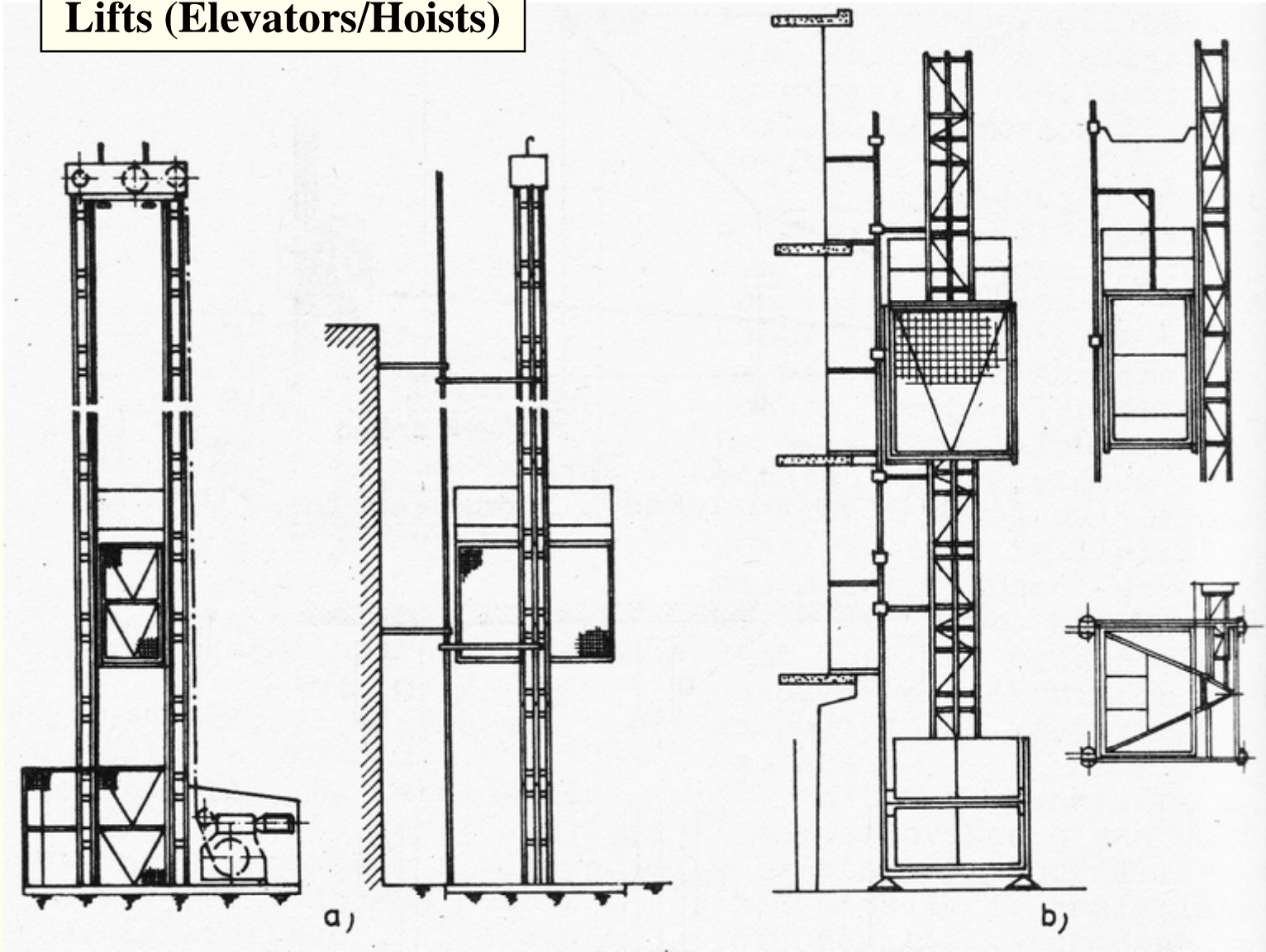

Cable operated

Ladder rack (rack bar) operated

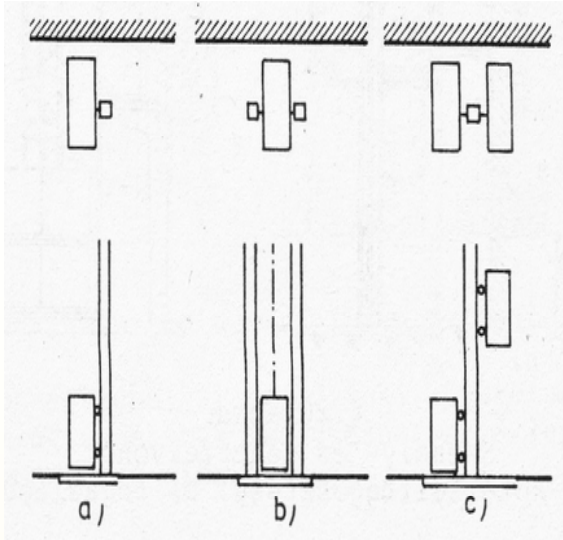

**a. single mast; b. twinmast;
c. single mast two cages**

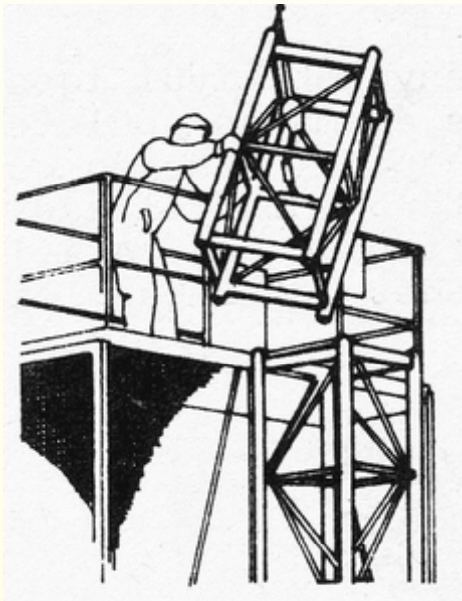

Extending the lift tower

Time-consumption of on-site vertical traffic

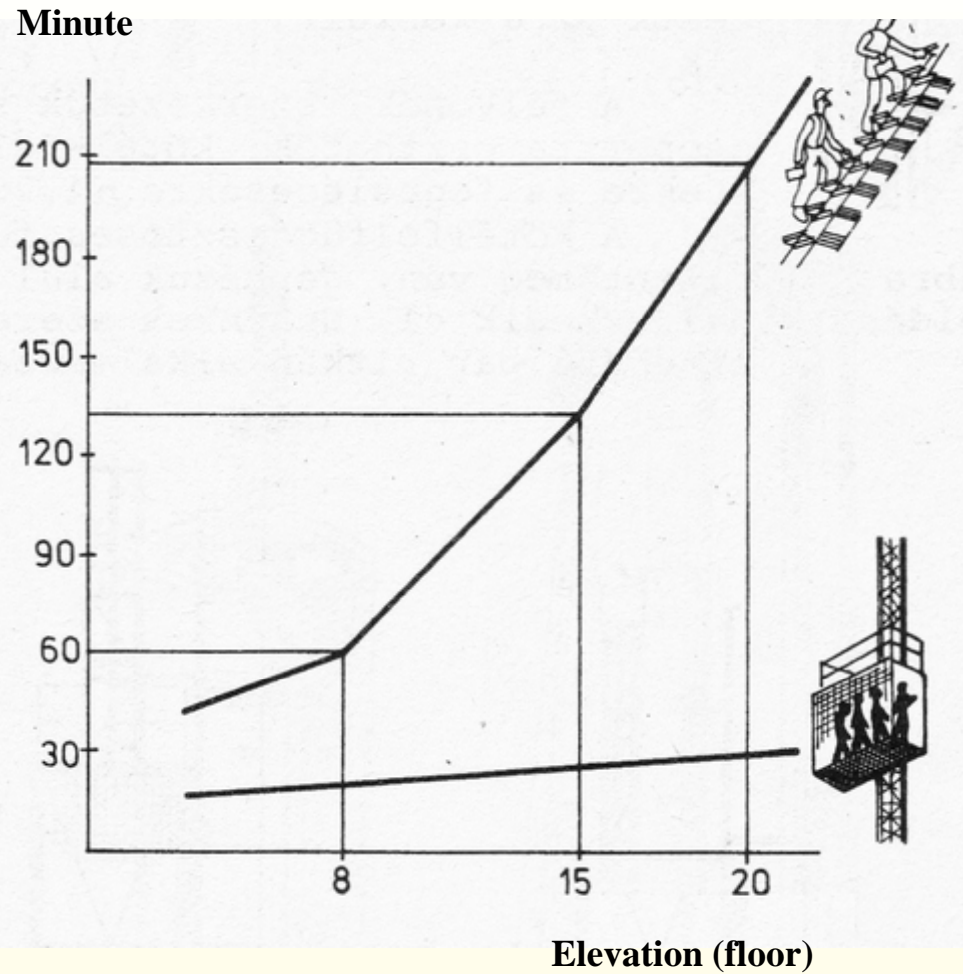

1. guide sheave; 2. cage frame; 3. frame post;
 4. climbing unit; 5. guide wheels;
 6. auxiliary platform; 7. shackle pin; 8. seat

Suspended scaffolds

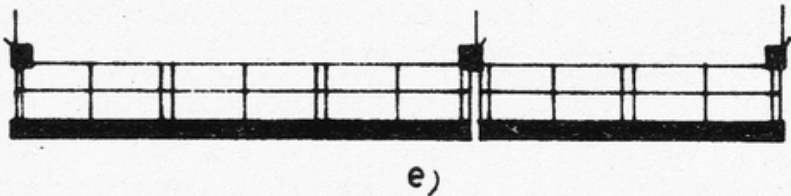
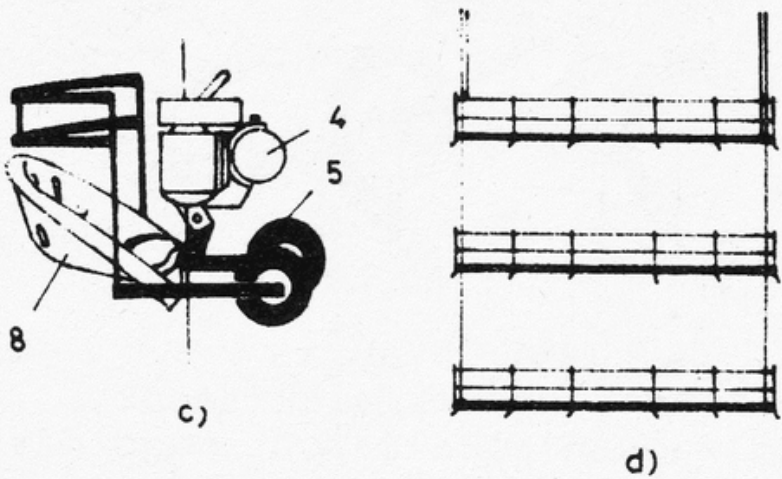
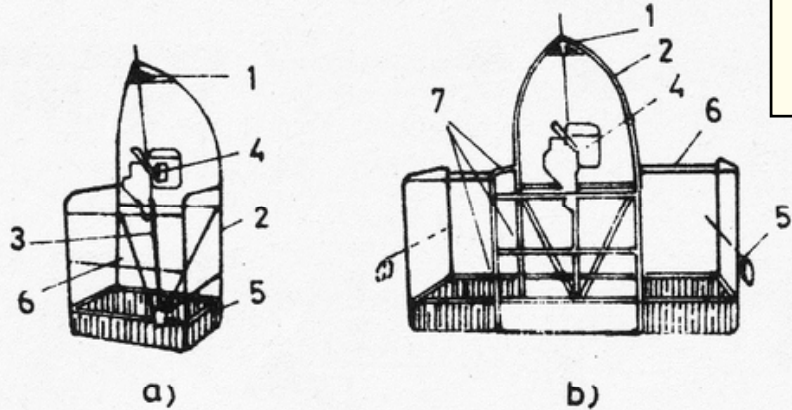

a. single-; b. extended-; c. one-man-;
 d. multistorey-; e. extensible cages

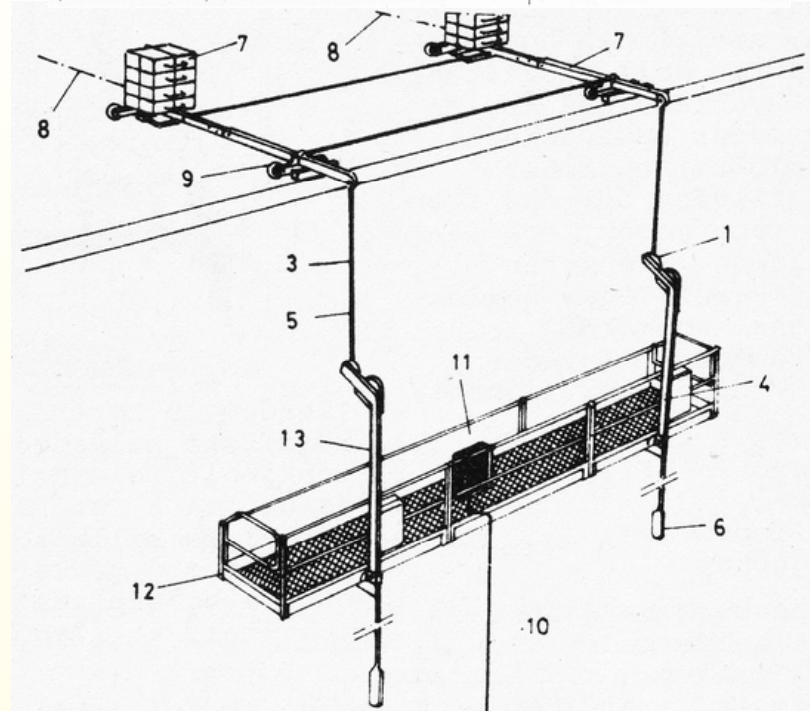
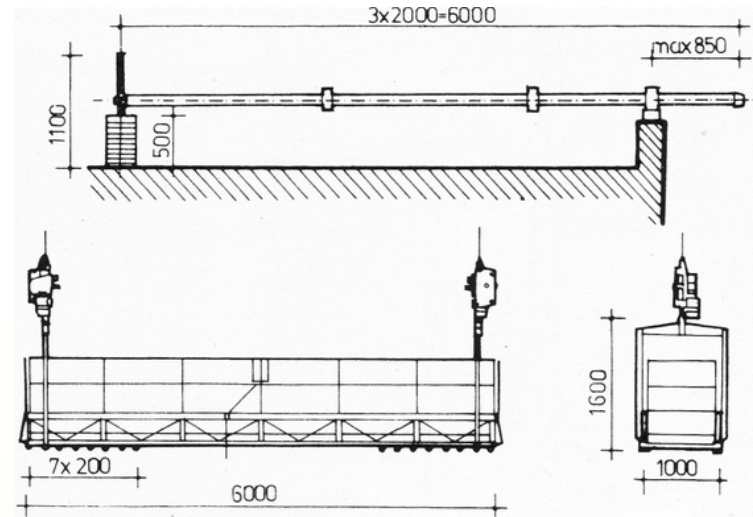

1. sheaves; 2. console; 3. lifting cable; 4. drive;
 5. stay line; 6. tension weight; 7. counter-weight;
 8. safety line; 9. idler; 10. floating line; 11. control;
 12. suspended bridge; 13. stabilizer frame post

Scissor Lift

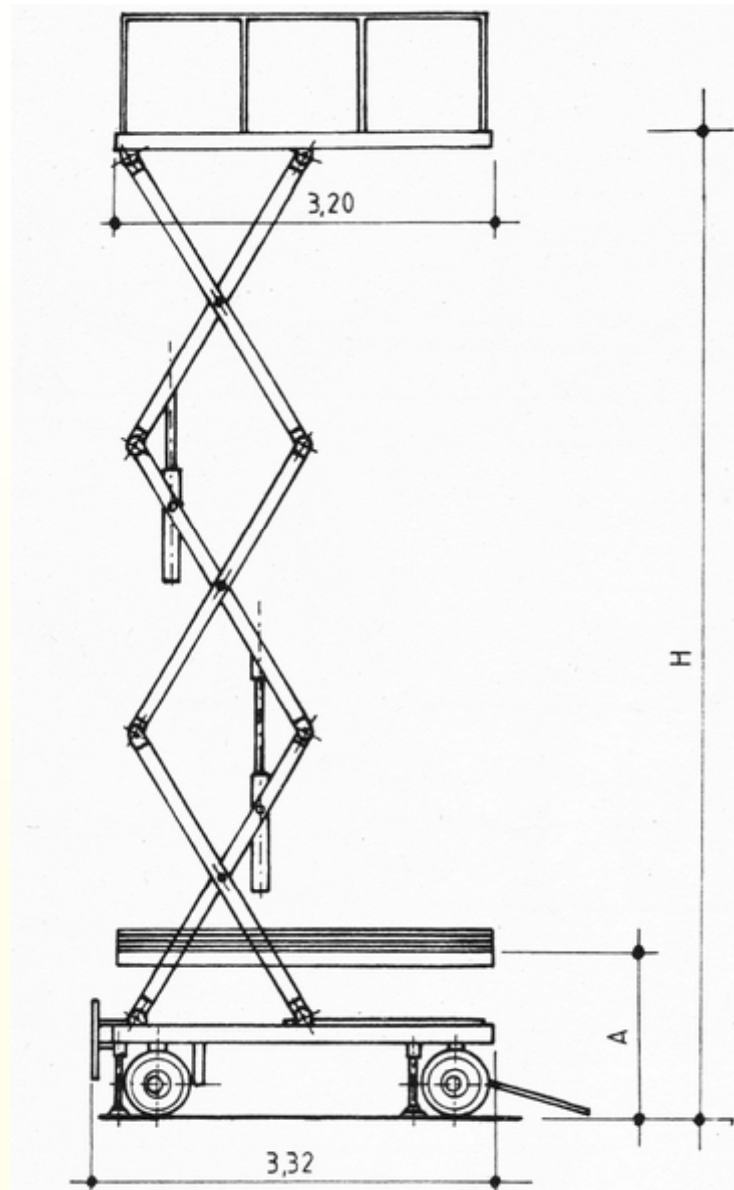

Assembly Platform

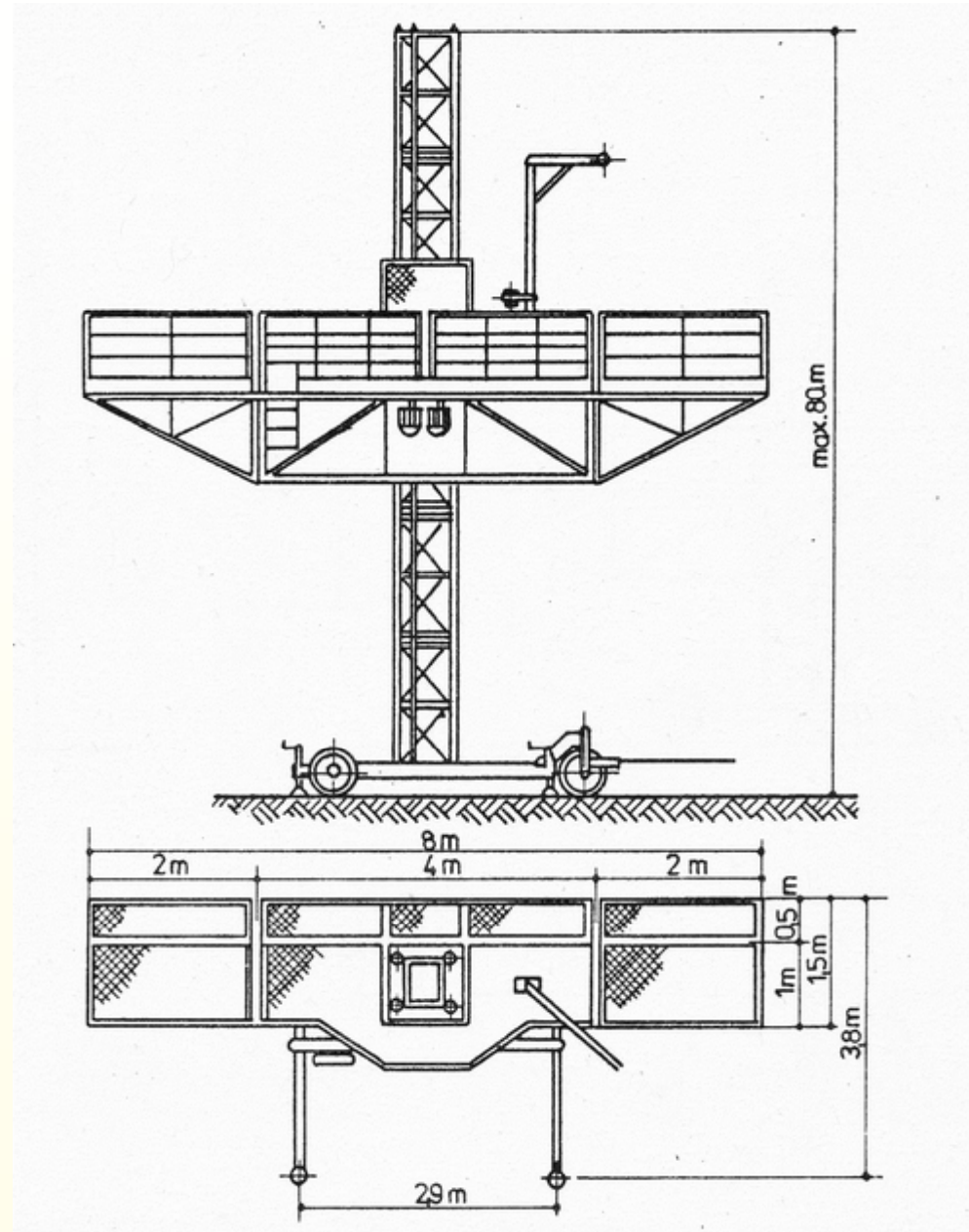

Twinmast Bridge Platform

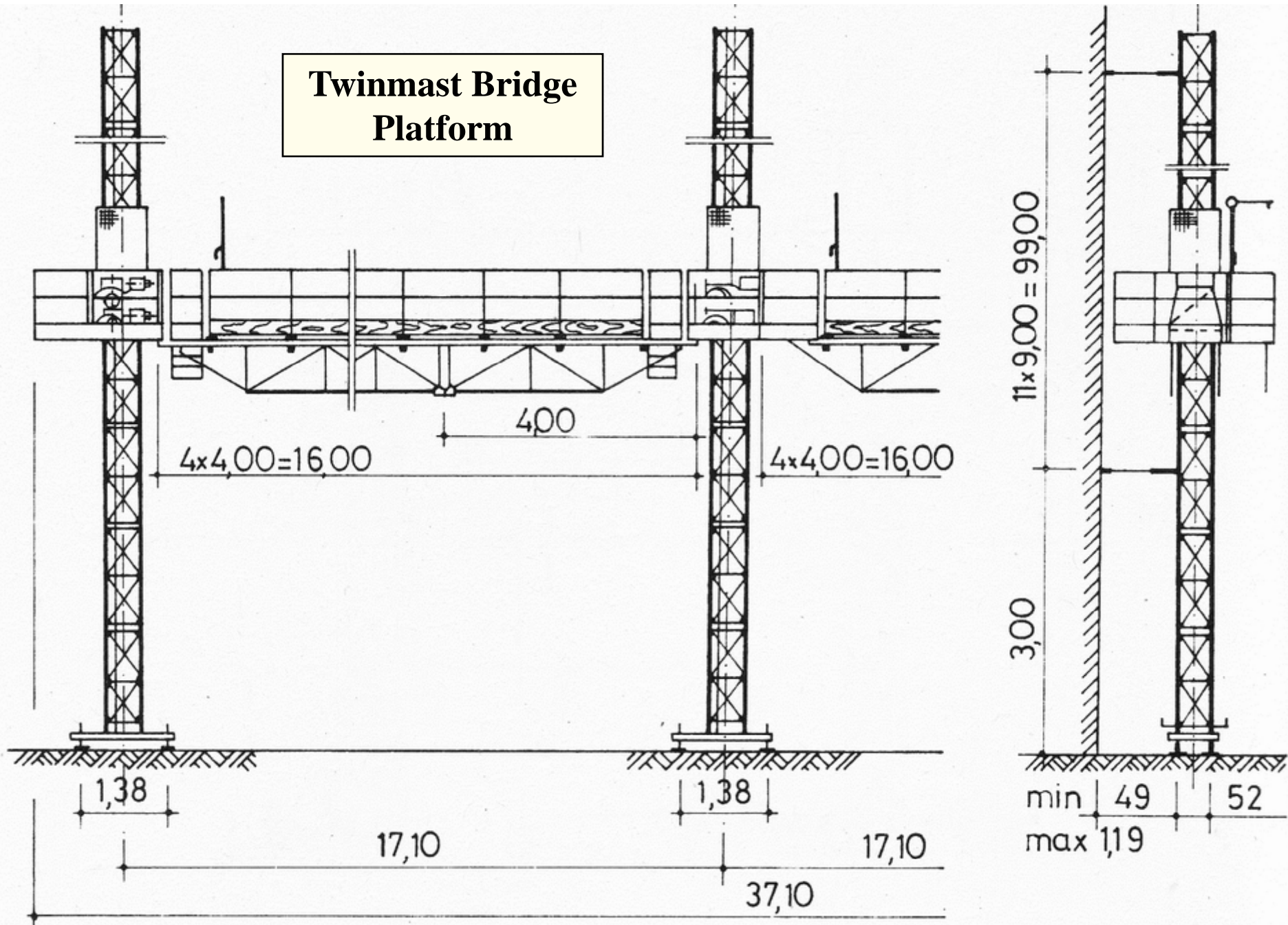

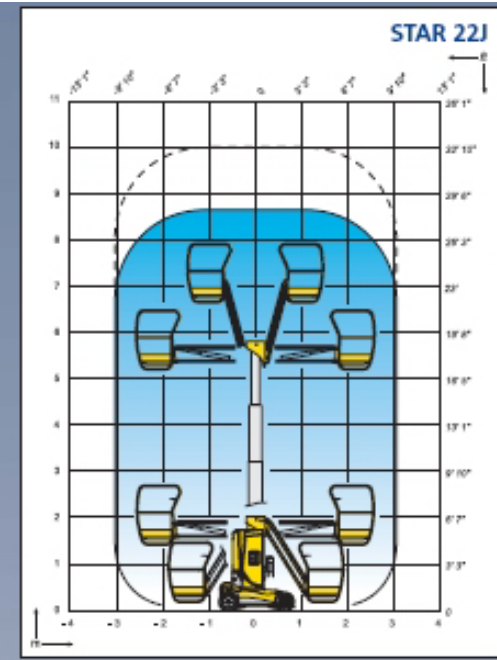
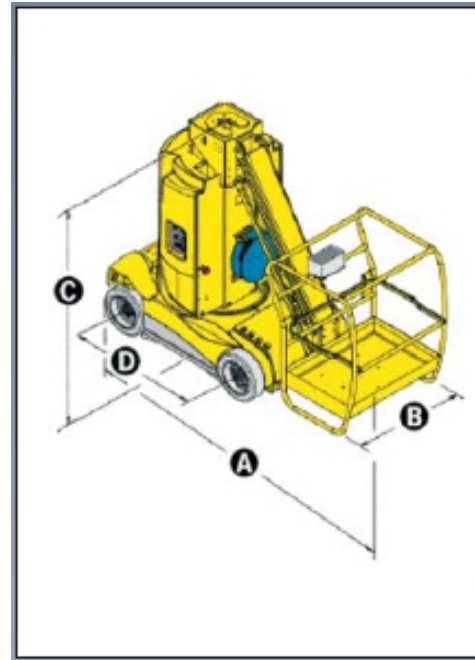
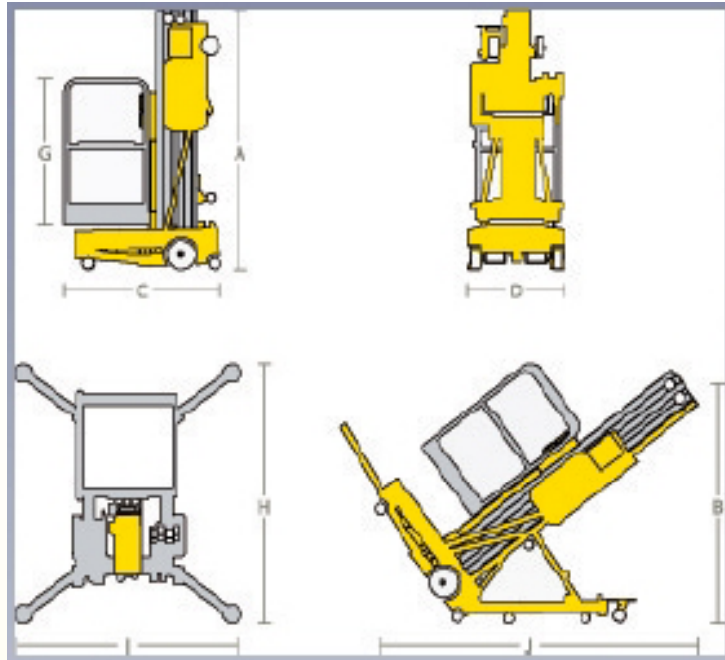

Cage-operated Working Platforms

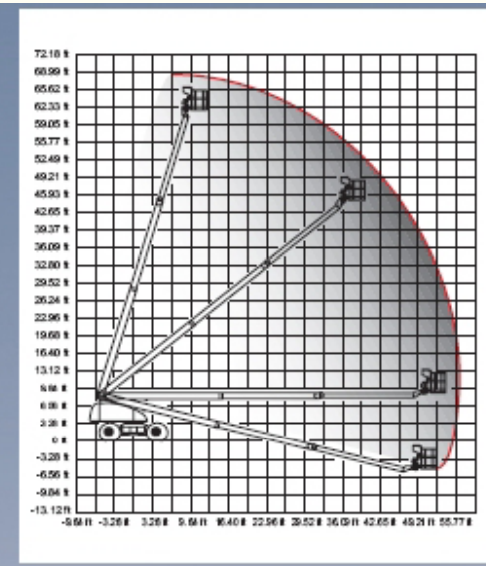
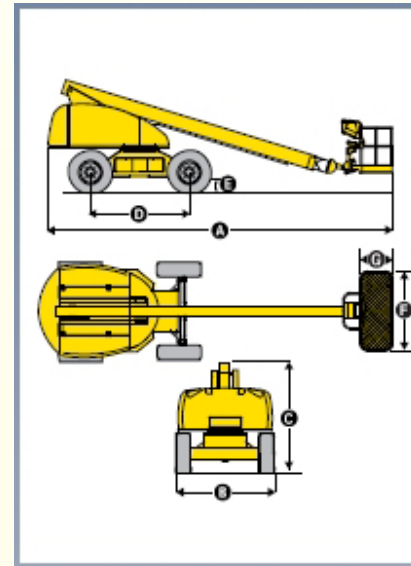
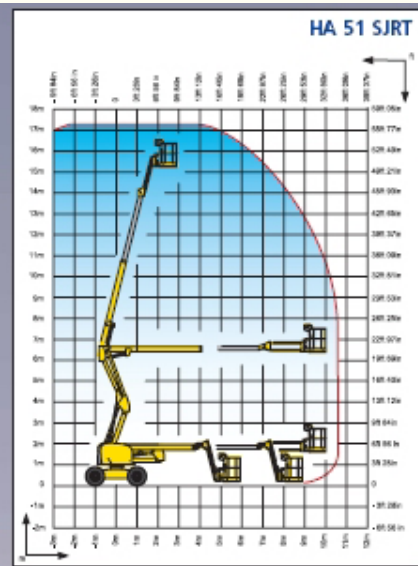
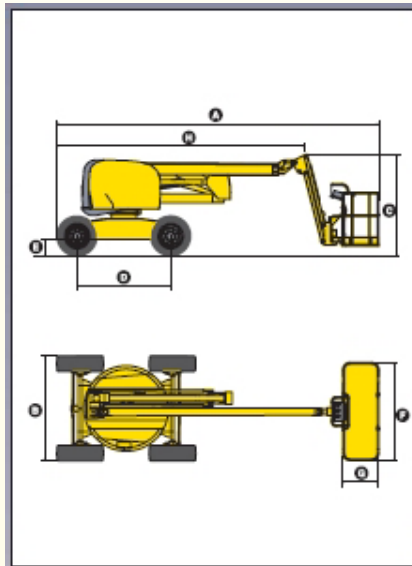

„Multicar” (Articulated, Vehicle-Mounted) Work Deck

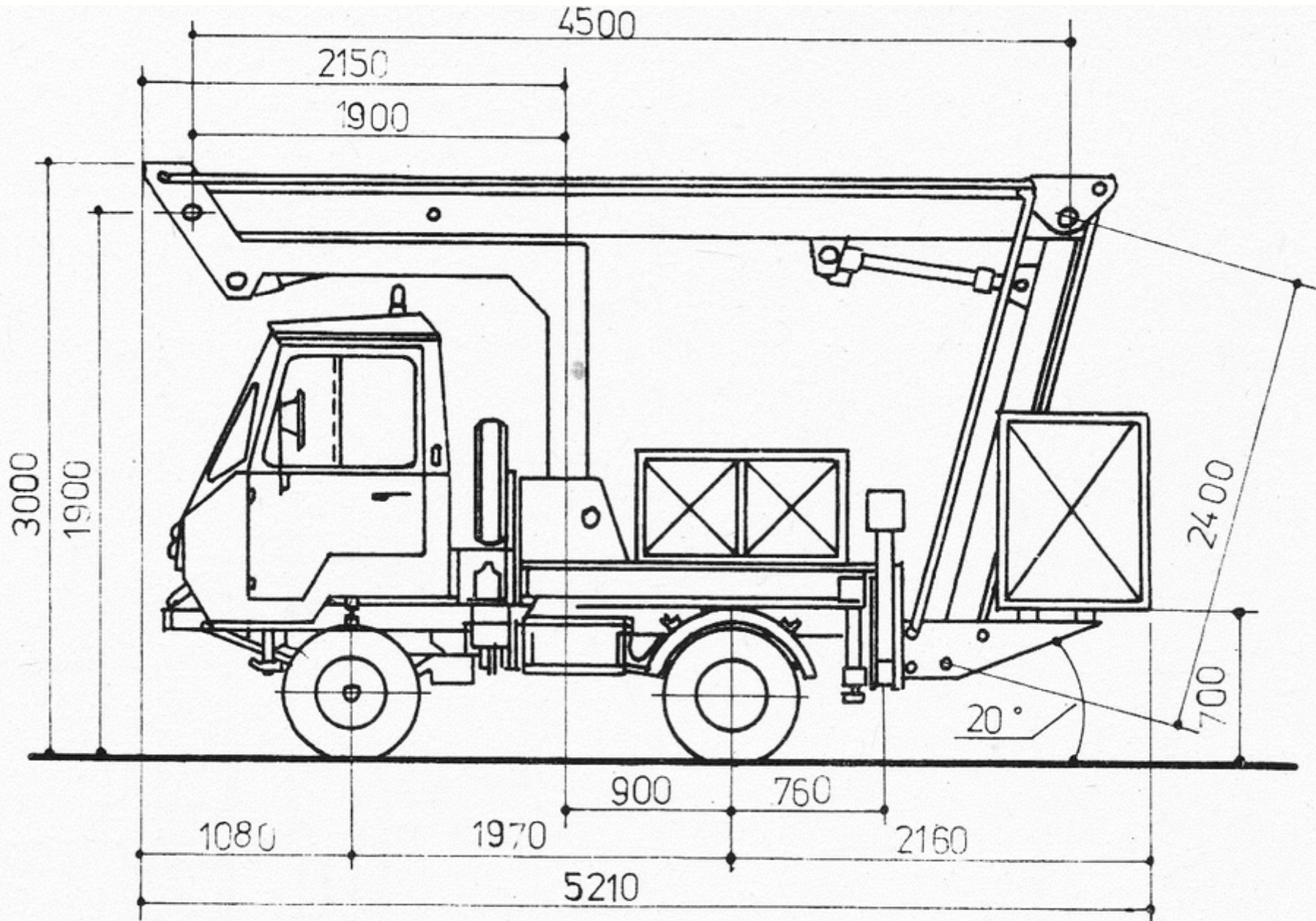

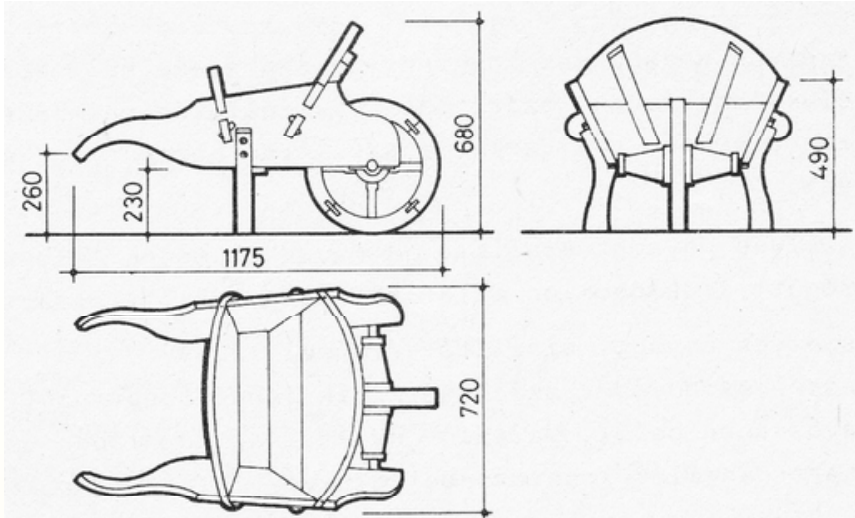

Navy's wheel-barrow

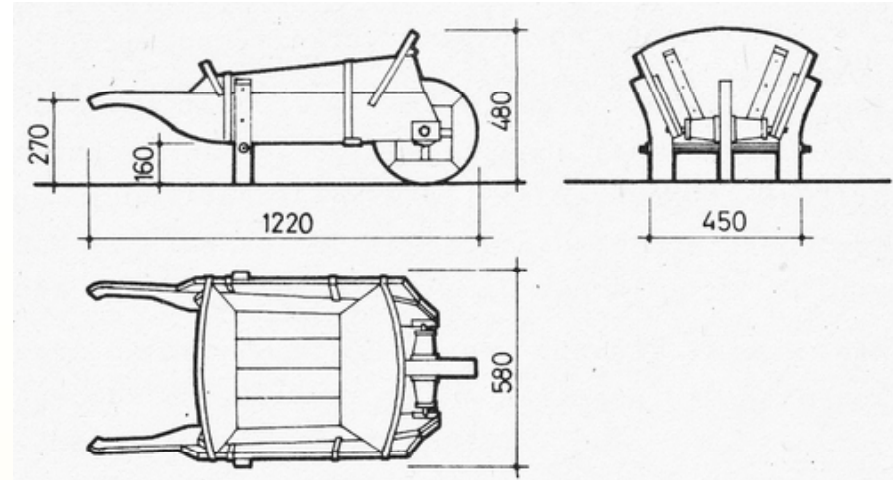

Builder's wheel-barrow

**Steel wheel-barrow
(general-purpose)**

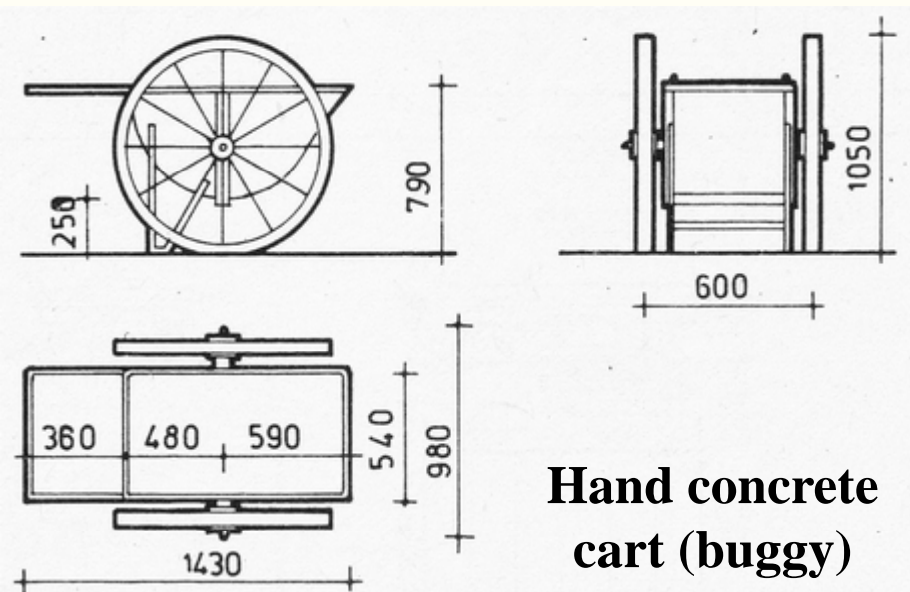
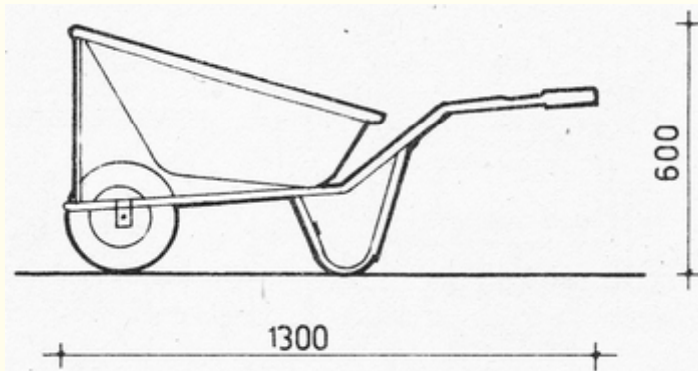

**Hand concrete
cart (buggy)**

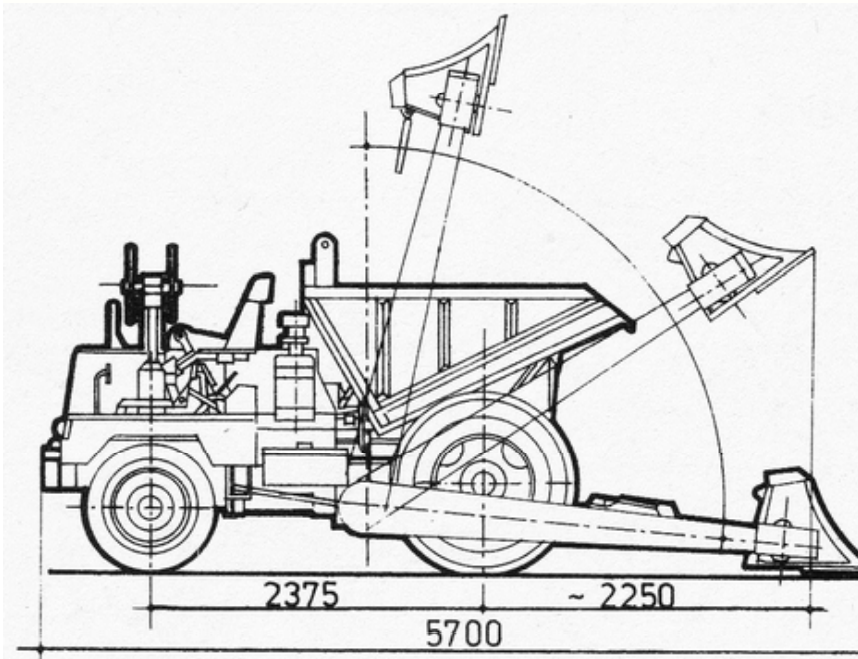
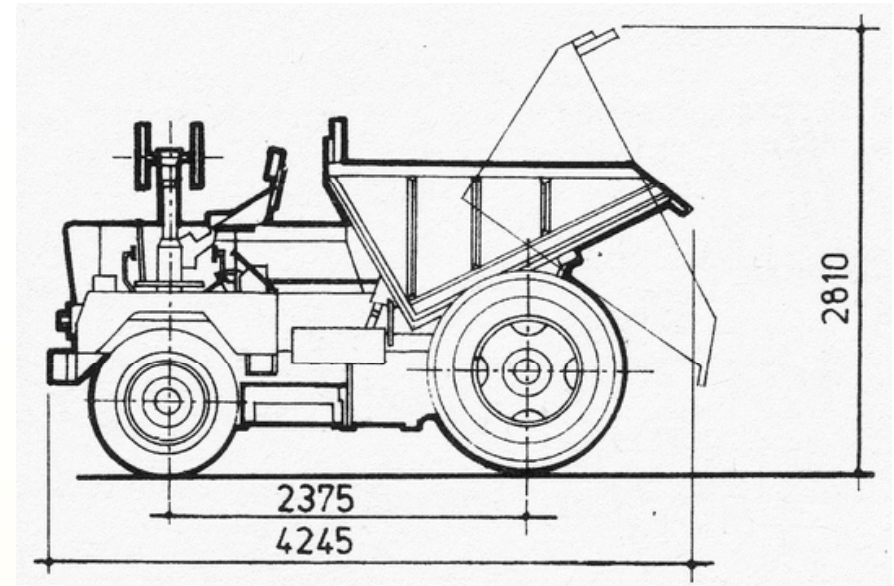
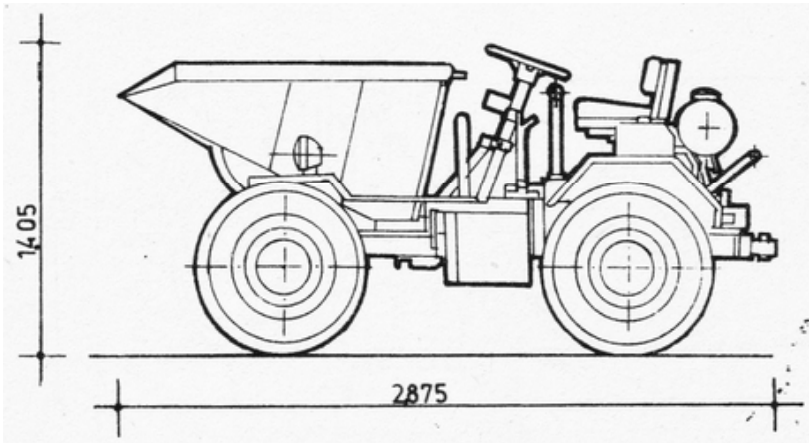

**From wheel-barrows through motobugs
(dumpers) to offroad trucks**

Self-loading shovel-motobug
(„DUTRA”)

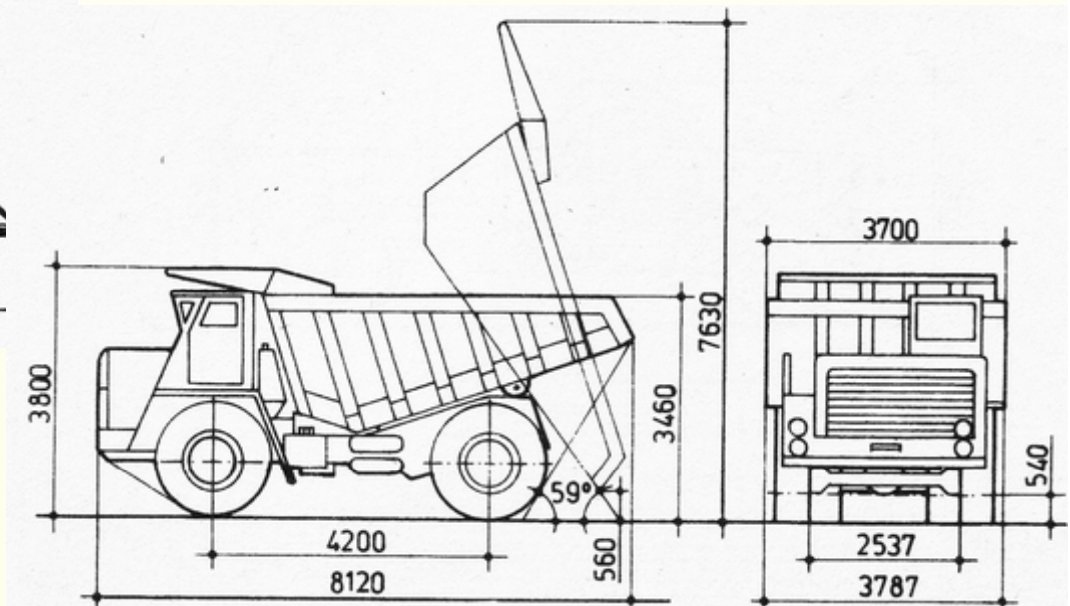

Special-purpose lorries (trucks)

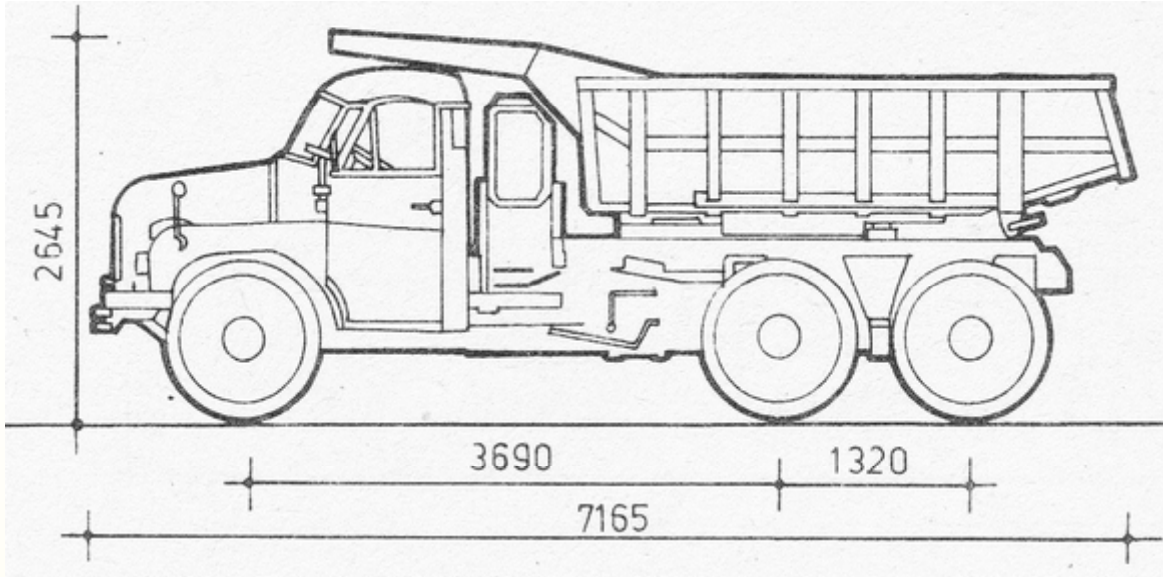

Dumper truck

Mixer truck

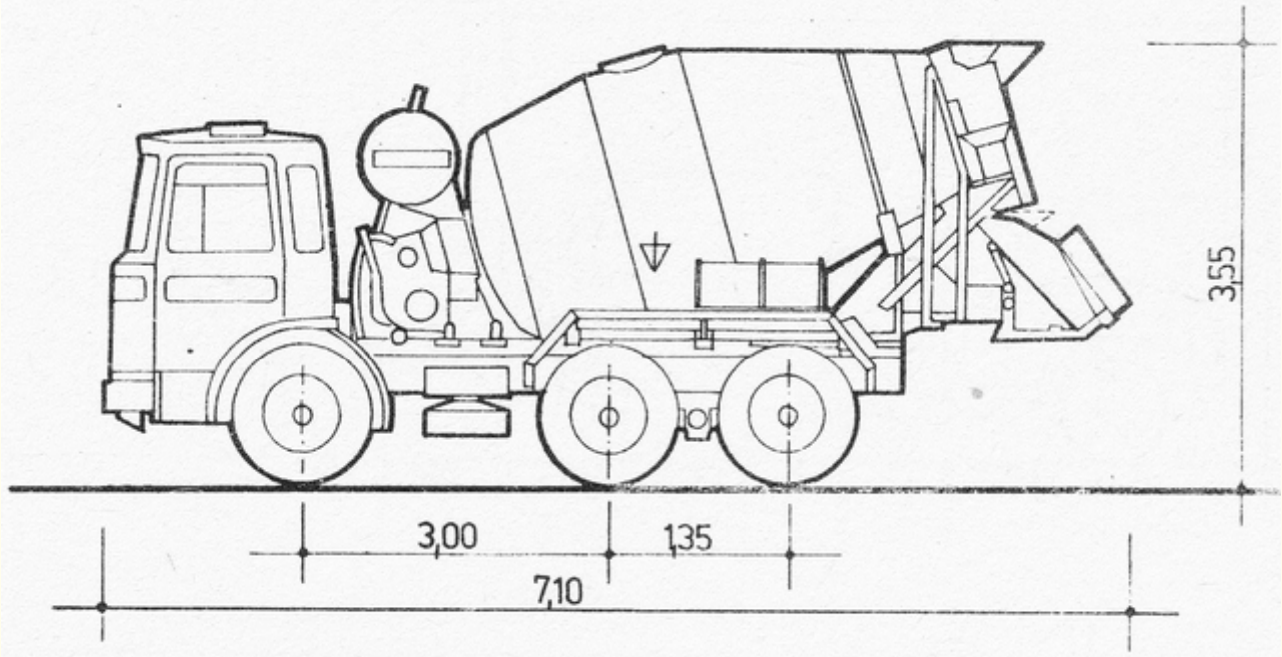

**Special-purpose
semi-trailers**

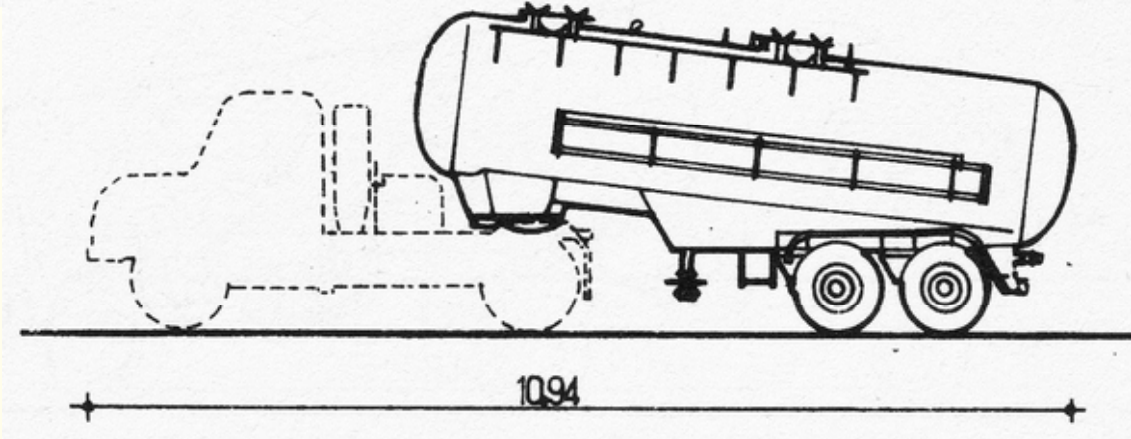
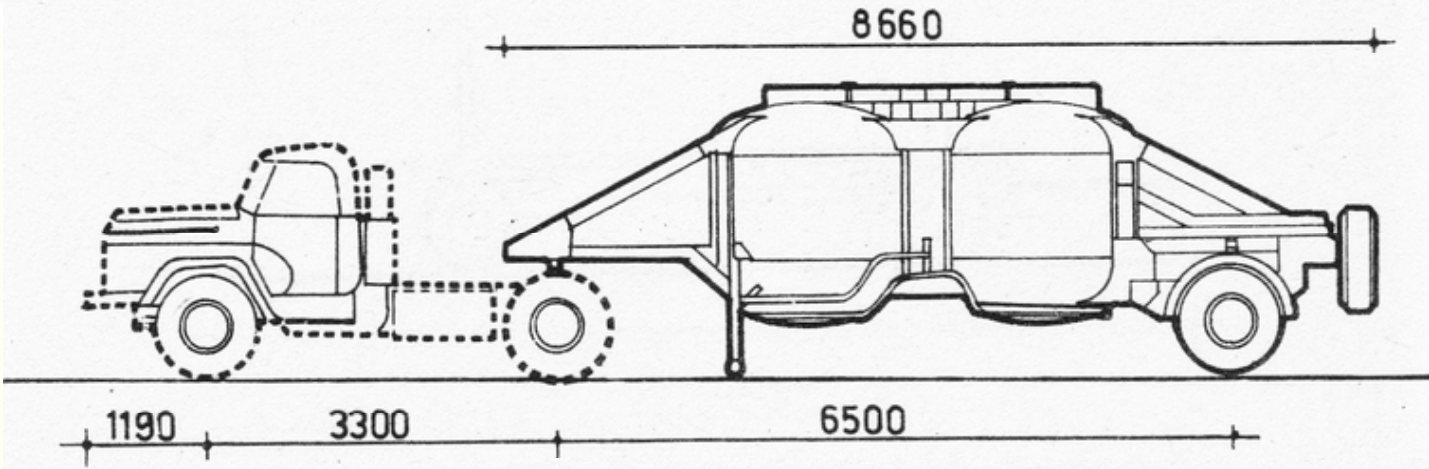
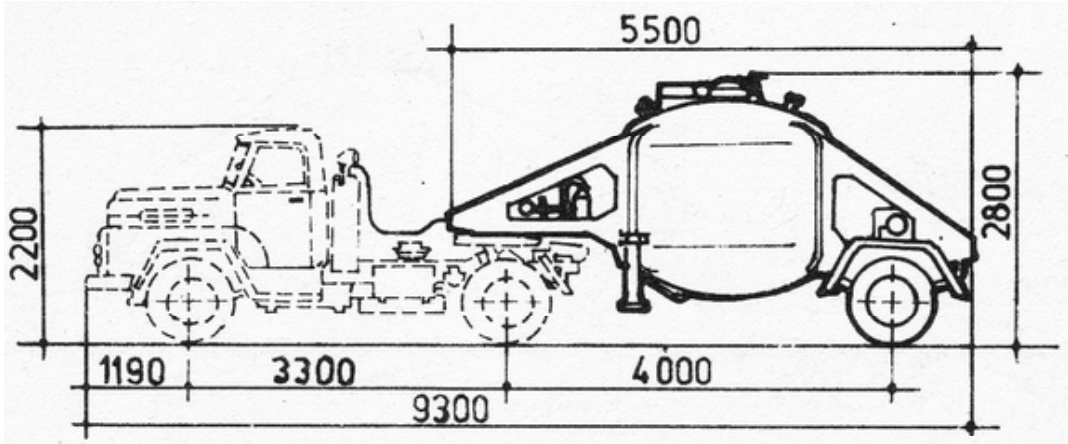

**Cement
transporters**

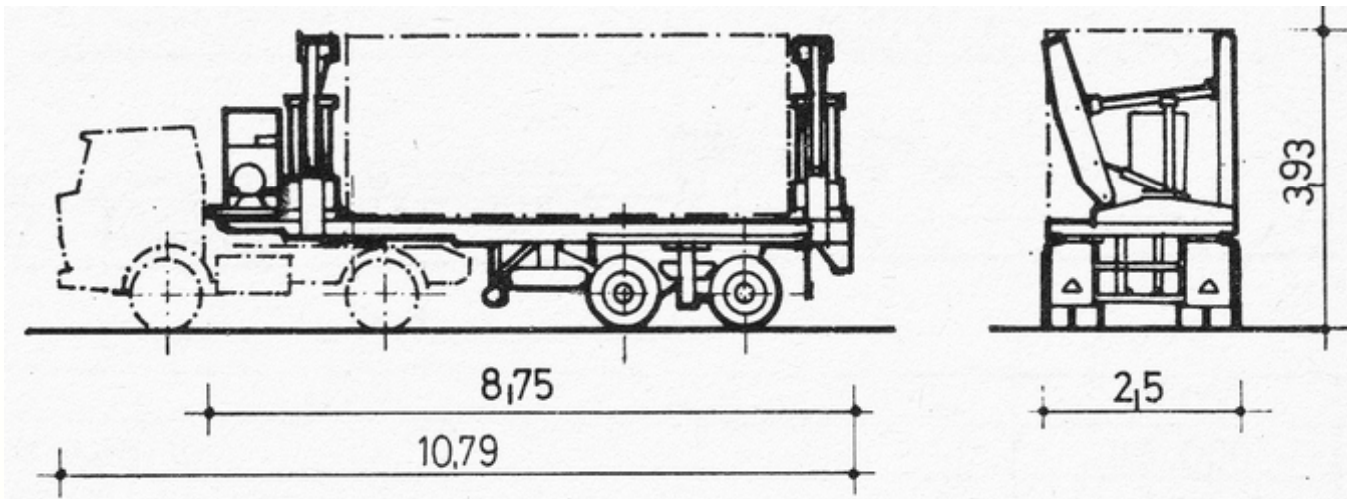

**(Self-loading)
Container
transporter**

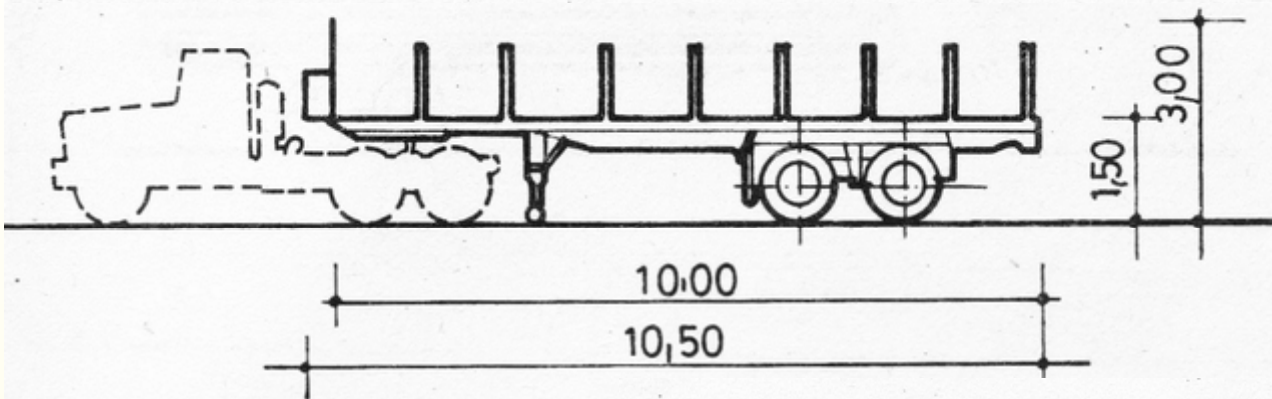

**Beam- and pipe
(log) transporter**

**Wall-panel
transporter**

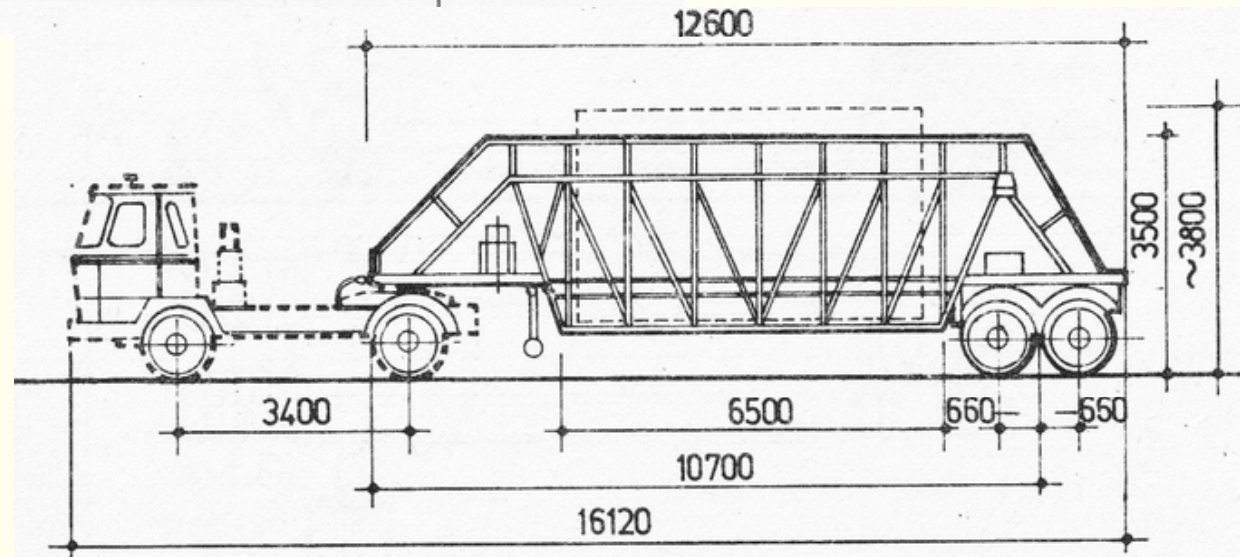

**Special-purpose
semi-trailers**

**Special-purpose
semi-trailers**

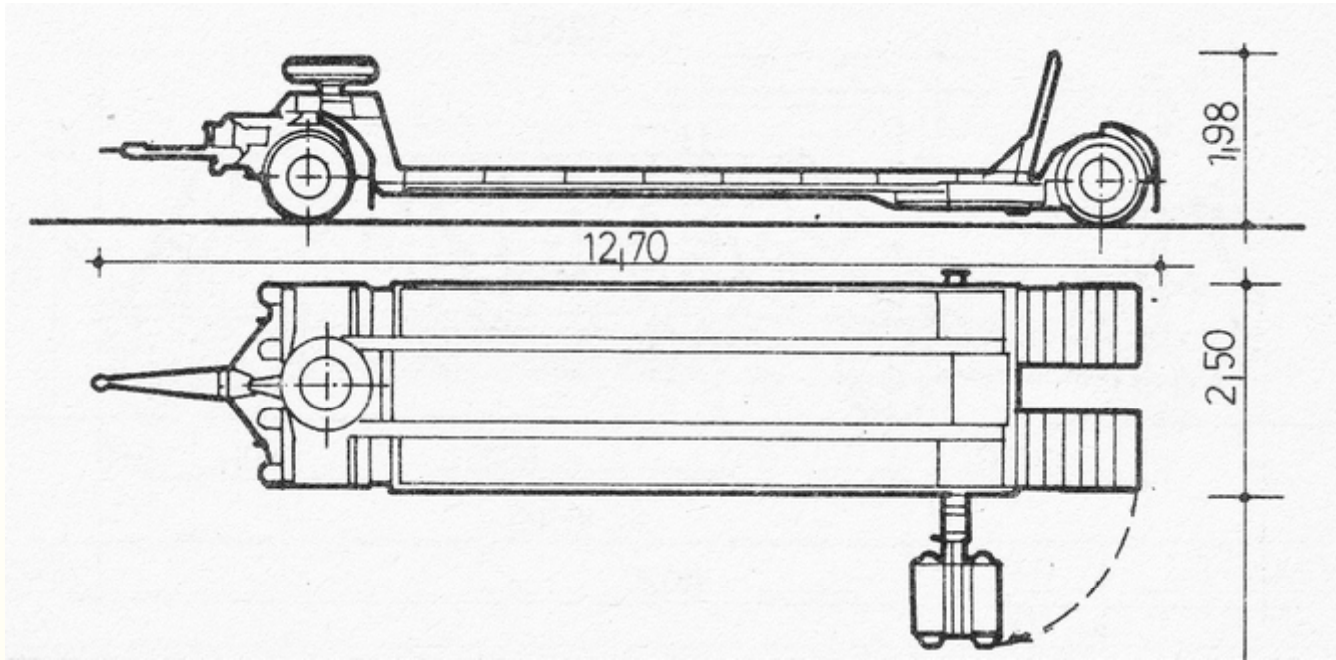

Equipment transporters

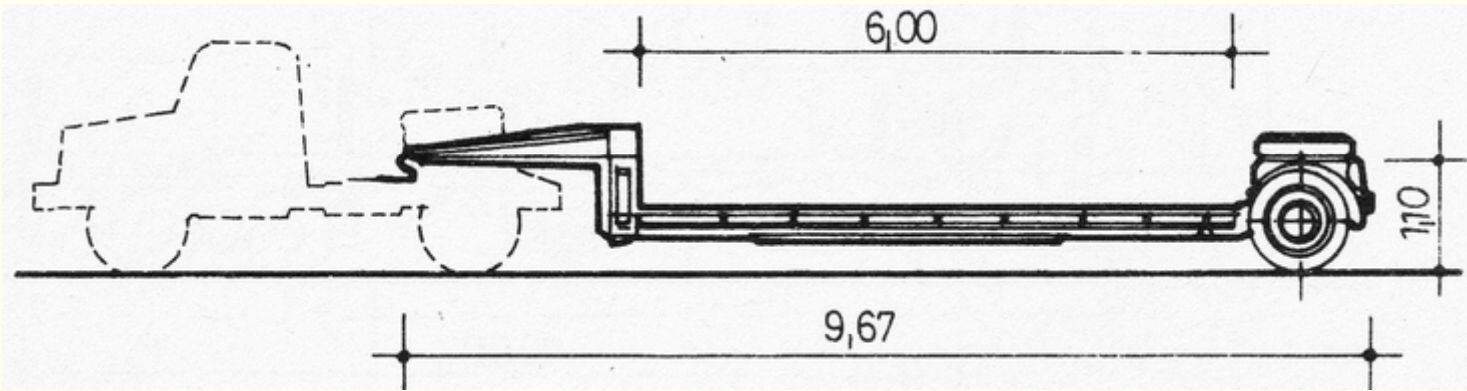

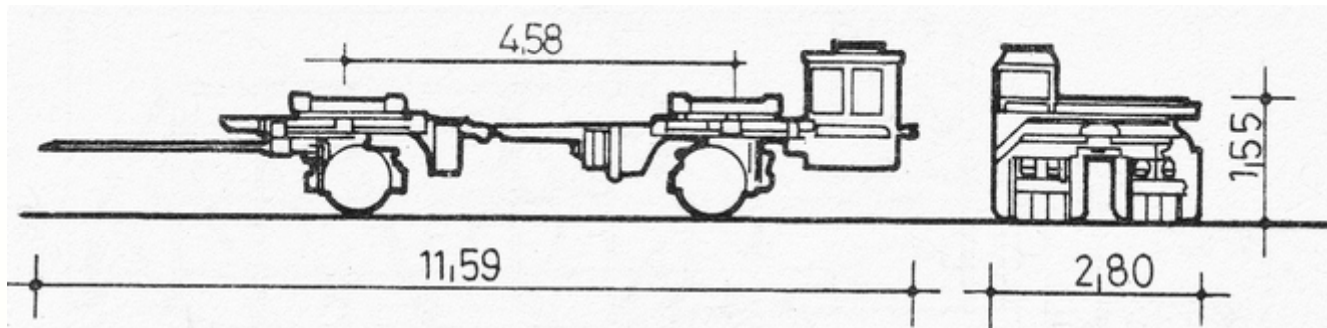

**Long freight transporter
(with steered rear wheels)**

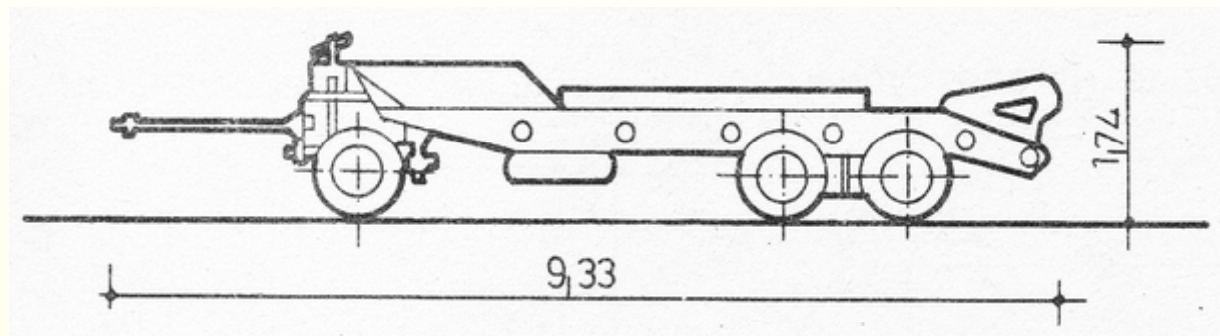

**Heavy equipment
transporters**

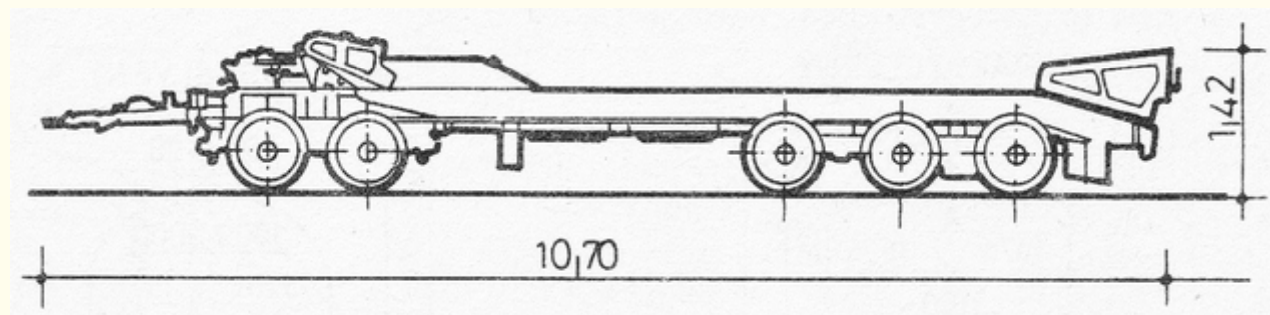

**Special-purpose
(semi-) trailers**

**Builder's
Conveyor Belt**

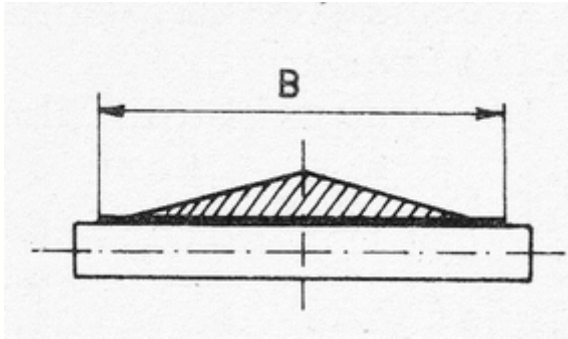

Flat conveyor

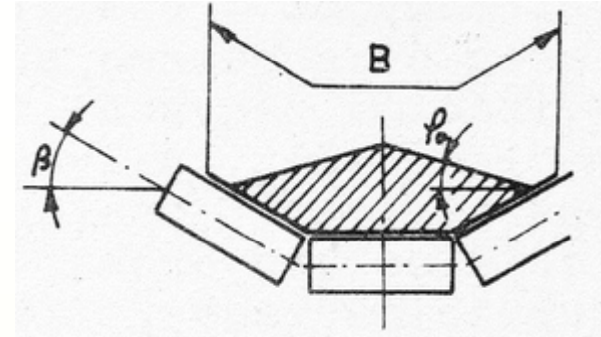

Trough conveyor

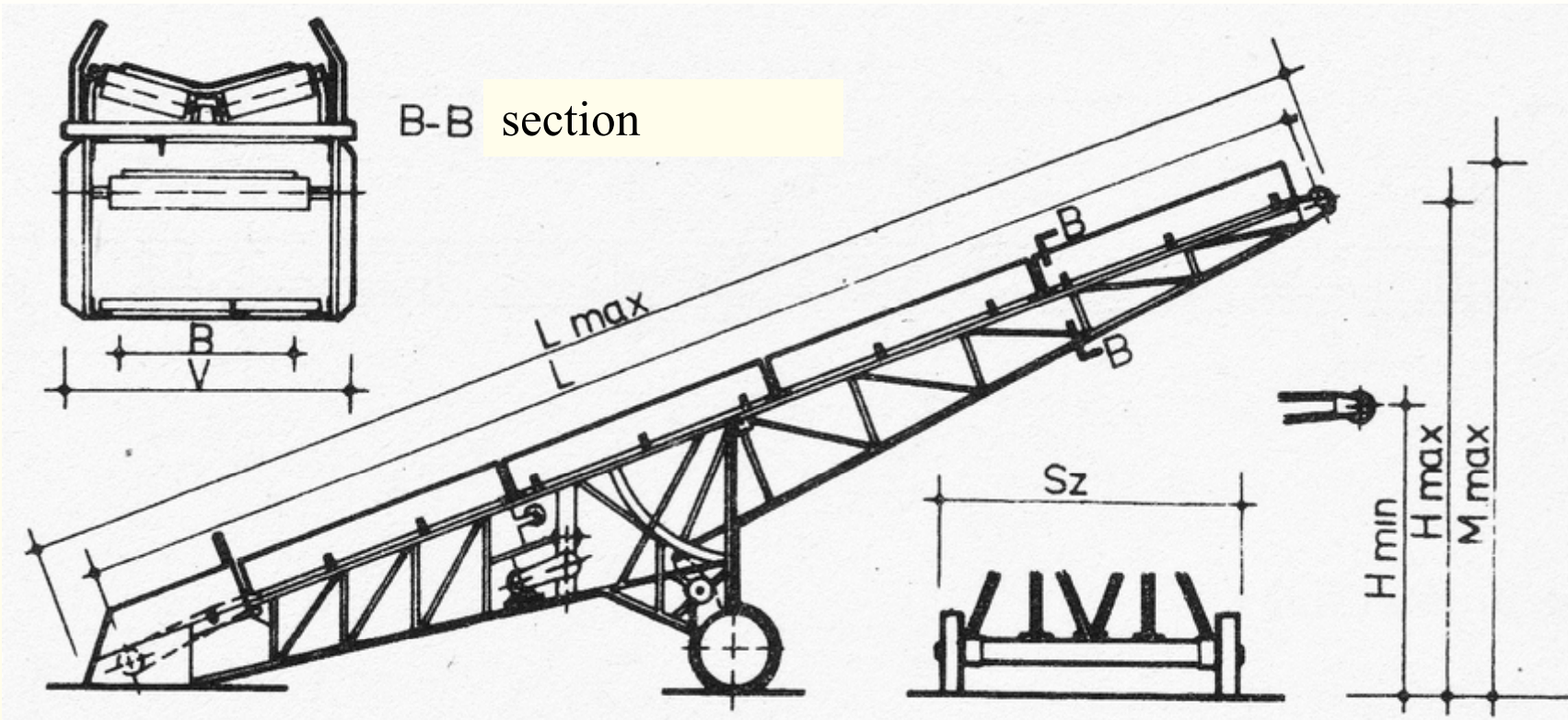

Sources of B&W pictures and drawings:

- Bacher Károly, Dr. Lánzos Pál, Dr. Soós László, Építésgépesítés I., Tankönyvkiadó, Budapest, 1985
- Dr. Nagy Pál, Építéstechnológia I, Alaptechnológiák, Tankönyvkiadó, Budapest, 1990
- Soós László, Építőipari gépek I., Tervezési segédlet, Tankönyvkiadó, Budapest, 1987
- Soós László, Építőipari gépek II, Tervezési segédlet, Tankönyvkiadó, Budapest, 1987
- Dr. Soós László, Építőipari emelőgépek, Tervezési segédlet, Tankönyvkiadó, Budapest, 1990