

FABULOUS ORIGAMI BOXES

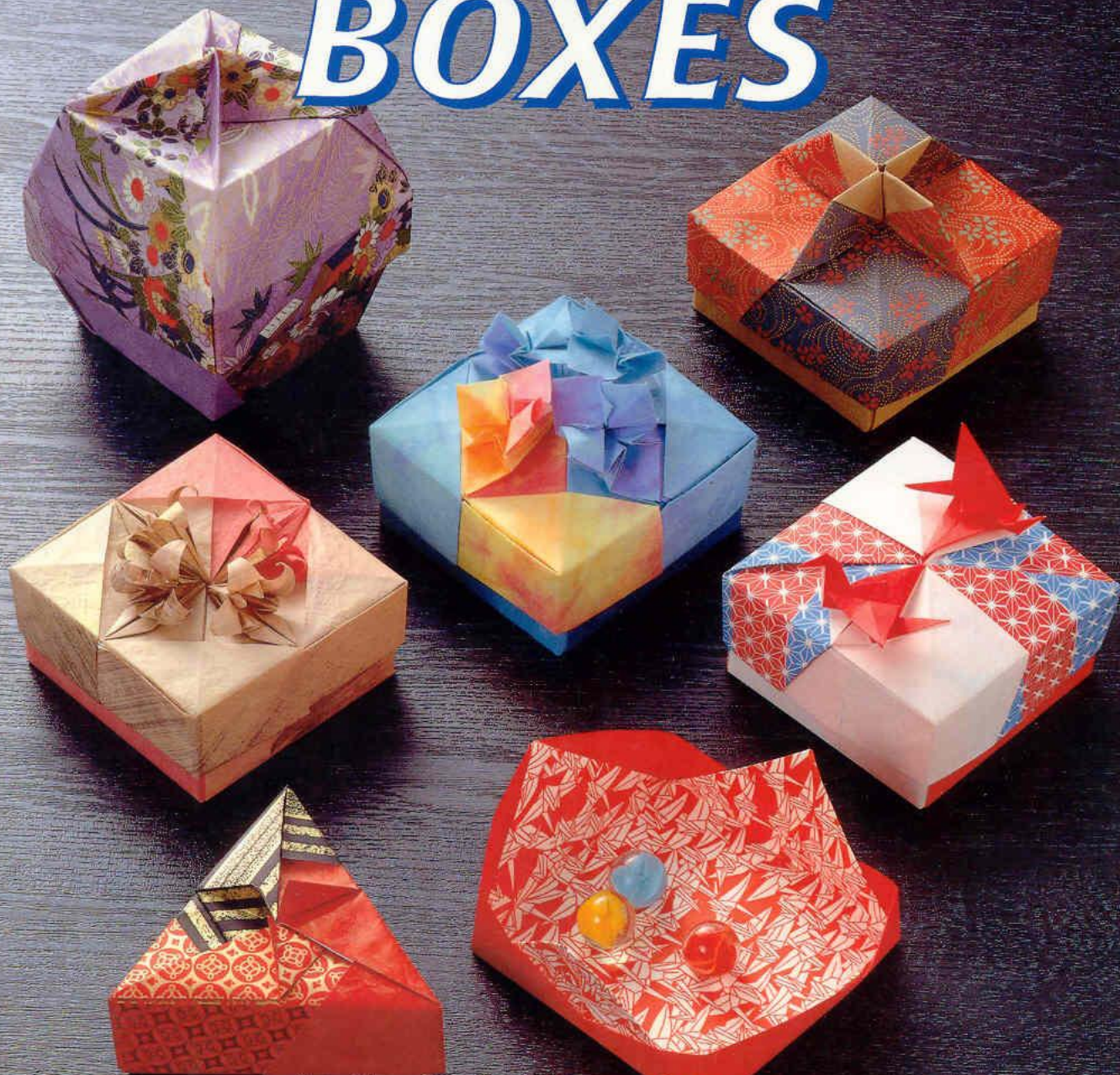

Author of *Origami Boxes*,
Quick & Easy Origami Boxes and *Unit Origami*
TOMOKO FUSE

©1998 by Tomoko Fuse

All rights reserved, including the right to reproduce this book or portions thereof in any form without the written permission of the publisher.

Published by Japan Publications Trading Co., Ltd.,
1-2-1 Sarugaku-cho, Chiyoda-ku, Tokyo, 101-0064 Japan

First edition, First printing: September 1998
Second printing: November 1998
Third printing: May 1999
Fourth printing: March 2000

Distributors:

United States: Kodansha America, Inc. through Oxford University Press,
198 Madison Avenue, New York, NY 10016.

Canada: Fitzhenry & Whiteside Ltd.,
195 Allstate Parkway, Markham, Ontario L3R 4T8.

United Kingdom and Europe: Premier Book Marketing Ltd.,
1 Gower Street, London WC1E 6HA, England.

Australia and New Zealand: Bookwise International,
54 Crittenden Road, Findon, South Australia 5023, Australia.

The Far East and Japan: Japan Publications Trading Co., Ltd.,
1-2-1 Sarugaku-cho, Chiyoda-ku, Tokyo, 101-0064 Japan.

10 9 8 7 6 5 4

ISBN 4-88996-041-4

Printed in Japan

CONTENTS

Preface 5

List of Color Illustrations 6

Symbols 15

Party Plate

Party Plate (1) from a square 16

Inside Liner 17

Party Plate (2) from a square 18

Party Plate (3) from a square 19

Party Plate (4) from a rectangle 20

Inside Liner 20

Triangle Box

Triangle Box (A) 22

Triangle Box (B) 24

Triangle Box (C, D) 25

Triangle Boxes Body & Nesting Boxes 26

Hexagon Box

Hexagon Box (A) 28

Hexagon Box (B) 30

Hexagon Box (C) 31

Hexagon Boxes Body & Nesting Boxes 34

Square Box

Square Boxes from a Rectangle 36

Square Box from a Rectangle Body 40

Lamp-shaped Bowl Standard 42

Measurements of Nesting Bowls 45

Lamp-shaped Bowl Lid with a knob 46

Square Box Plain 48

Square Box Crane I 51

Square Boxes	Iris & Bouvardia	54
Square Box	Heart	56
Square Boxes	Rabbit & Butterfly	58
Square Box with a Tab		60
Square Box	Vortex	62
Square Box	Hydrangea	64
Square Boxes	Plain 2 & Crane 2	67
Square Box	Lily	68
Square Box	Body 1 & Inside Liner	70
Square Box	Body 2	72
Square Box	Body 3	74
Square Boxes	Body & Nesting Boxes	76
Rectangle Box	Individual Plate	78

Octagon Box

Octagon Box	Small Flower (A)	80
	Variations of Small Flower (A) - a, b	82
Octagon Box	Small Flower (B)	83
	Variations of Small Flower (B) - a, b, c, d	84
Octagon Box	Twin Stars	86
	Variations of Twin Stars - a, b, c	88
Octagon Box	Plain	89
	Variations of Plain Boxes - a, b, c	91
Octagon Box	Body	92
Nesting Octagon Boxes		94

PREFACE

Making origami boxes is endless fun. It is enjoyable to think about what color and kind of paper are best for a project, what the box will be used for, and for whom it is made. The feel of the paper and step-by-step procedure makes for peace and contentment. It is exciting to see the individual units form a box with colorful patterns and decorations. Once you try your hand at origami boxes, you will be captivated by their real appeal, beauty and cuteness.

Included in this book are triangle, square, hexagon and octagon boxes. There are simple party plates and bowls. Some boxes are made of square paper and others of rectangular paper. Some boxes form flowers, hearts and butterflies. We hope that the variety in this book will start you on your way towards enjoying a life full of origami boxes.

January 30, 1998

Tomoko Fuse

List of Color Illustrations

Photo page	Instruction page	Photo page	Instruction page
<i>Front Cover</i>		<i>Page 11</i>	
Lamp-shaped Bowl with a knob	46~47	No.22 Nesting Triangle Boxes	26~27
Square Box - Lily	68~69	23 Hexagon Box (A)	28~29
Triangle Box (C)	25	24 Square Boxes from a rectangle	36~37
Square Box - Hydrangea	64~66	25 Square Box - Plain 2 & Crane 2	67
Party Plate (1) with Inside Liner	16~17	<i>Page 12</i>	
Square Box with a tab	60	No.26 Square Box	
Square Box - Crane 1	51~53	- Body & Nesting Boxes	76
<i>Page 7</i>		27 Octagon Box - Twin Stars "c"	86~88
No. 1 Lily (traditional)	68~69	28 Octagon Box	
2 Square Box - Lily	68~69	- Small Flower (A) "b"	80~82
3 Lily (traditional)	68~69	29 Square Box - Butterfly	58~59
4 Party Plate (4) with Inside Liner 2	20~21	<i>Page 13</i>	
5 Party Plate (2) with Inside Liner	18	No.30 Party Plate (3) with Inside Liner	19
6 Octagon Box - Small Flower (A)	80~81	31 Octagon Box - Plain "b"	89~91
7 Square Box - Iris	54	32 Square Box - Bouvardia	54~55
<i>Page 8</i>		33 Square Box - Rabbit	58
No. 8 Square Box - Body 1 & Inside Liner	70~71	<i>Page 14</i>	
9 Square Box - Plain	48~50	No.34 Square Box - Hydrangea	64~66
10 Square Box - Iris	54	35 Lamp-shaped Bowl - Standard	42~44
11 Square Box "Lightning"	36~38	36 Octagon Box - Twin Stars	86~87
12 Hexagon Box (B)	30	37 Hexagon Box (C)	31~32
<i>Page 9</i>		38 Triangle Box - Body	26
No.13 Nesting Bowls	45	39 Triangle Box (D)	25
14 Square Box - Vortex "B"	62~63	<i>Back Cover</i>	
15 Square Box - Butterfly	58~59	Party Plate (1) with Inside Liner	16~17
16 Hexagon Box (C)	31~32	Square Box - Crane 1	51~53
<i>Page 10</i>		Square Box - Body 2	72~73
No.17 Triangle Box (A)	22~23	Square Box - Vortex "A"	62~63
18 Triangle Box (B)	24		
19 Square Box - Body	70~71		
20 Square Box - Heart	56~57		
21 Square Box - Vortex	62~63		



2

1

7

6

3

4

5



8

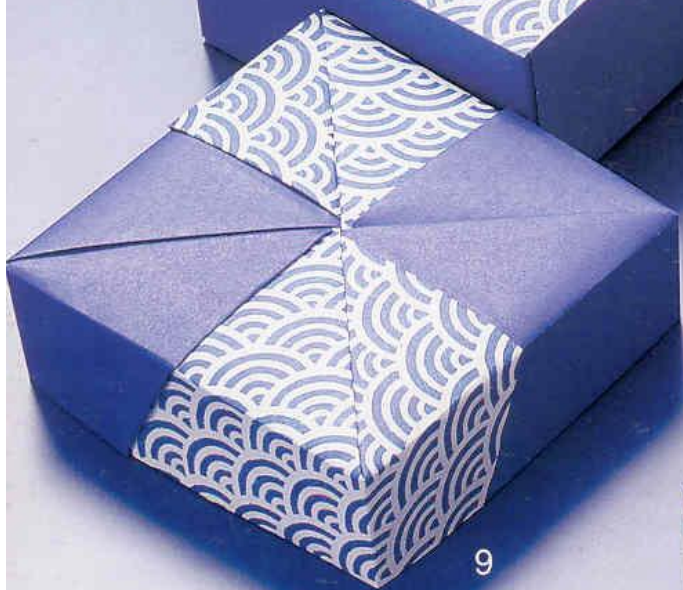

9

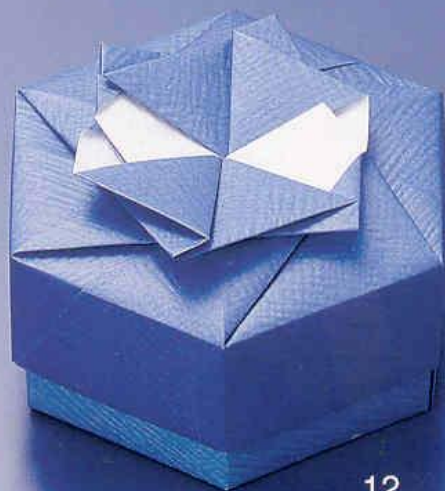

12



11

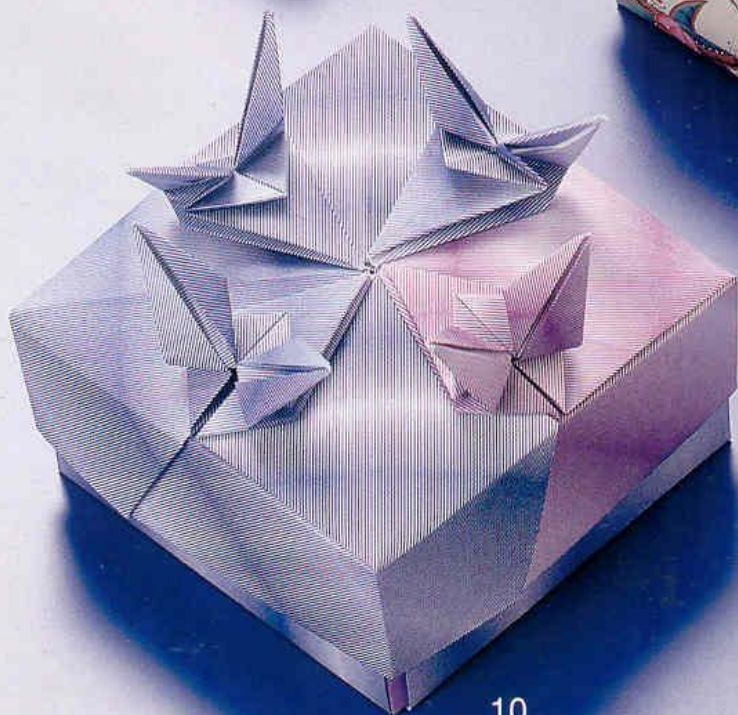

10



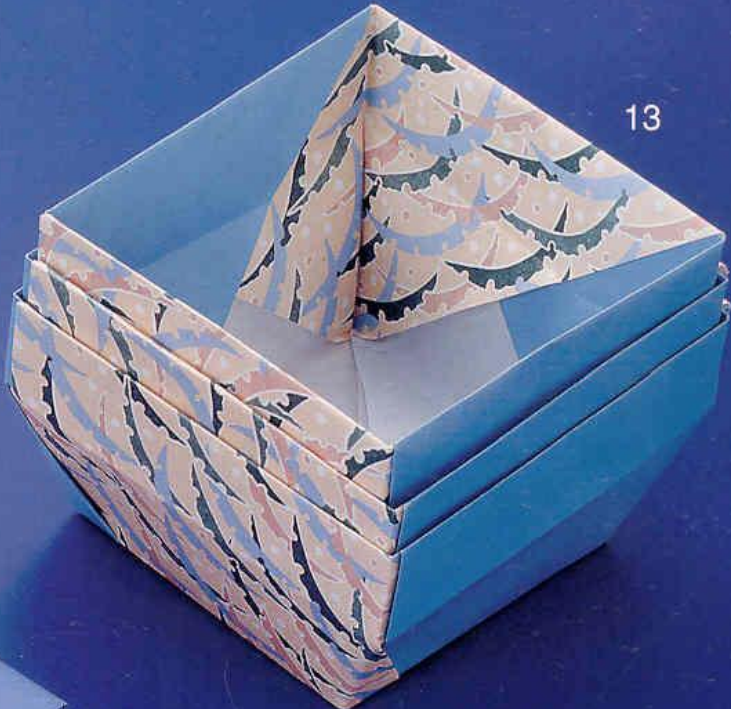

13

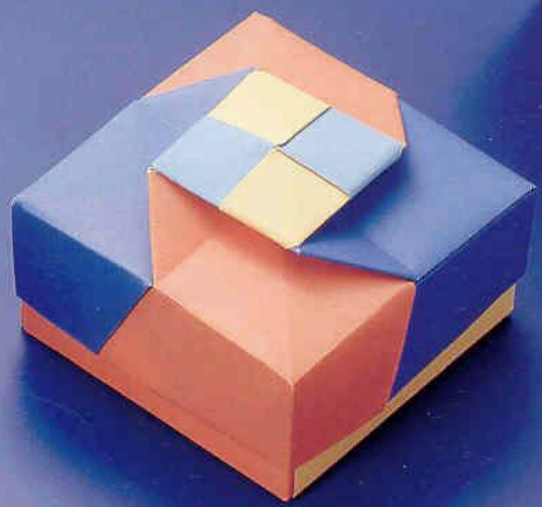

14

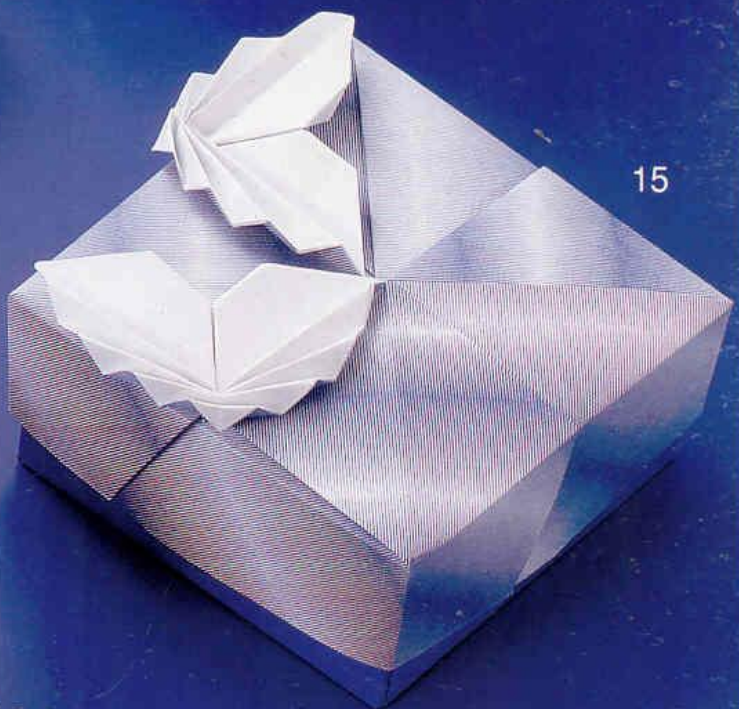

15



16

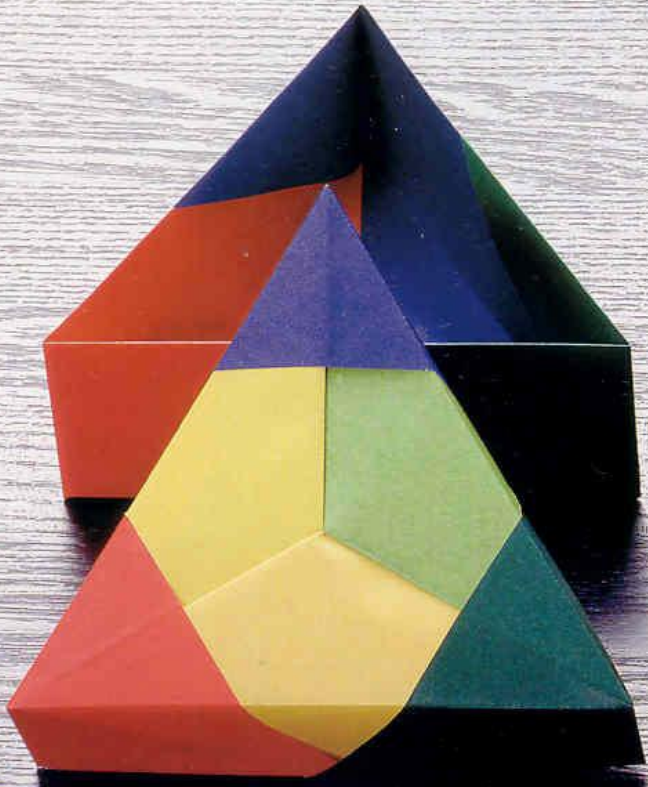

17

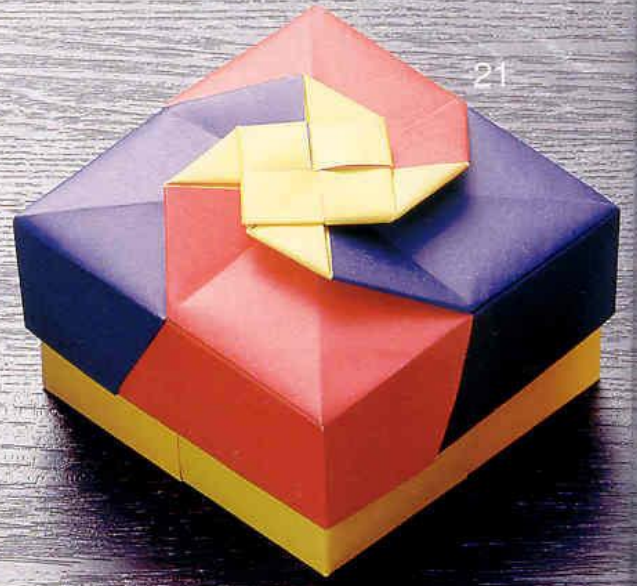

21

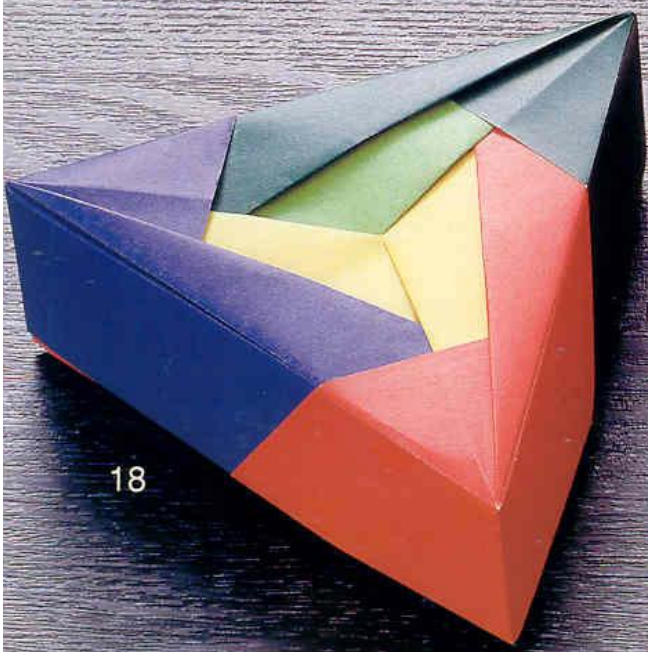

18



20

19



22

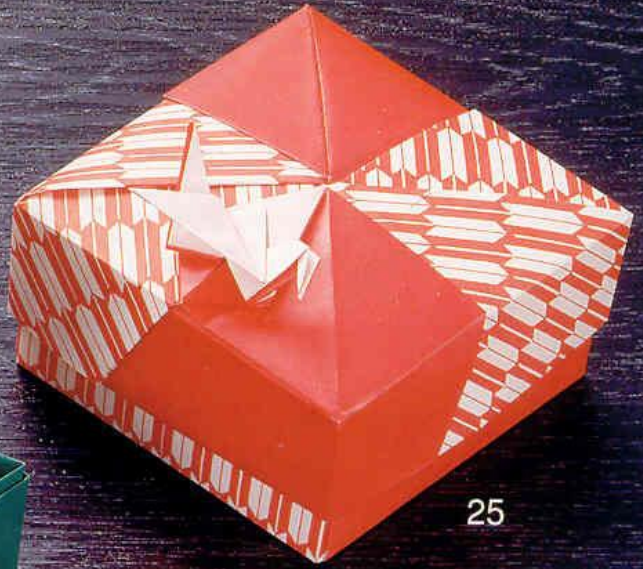

25



23

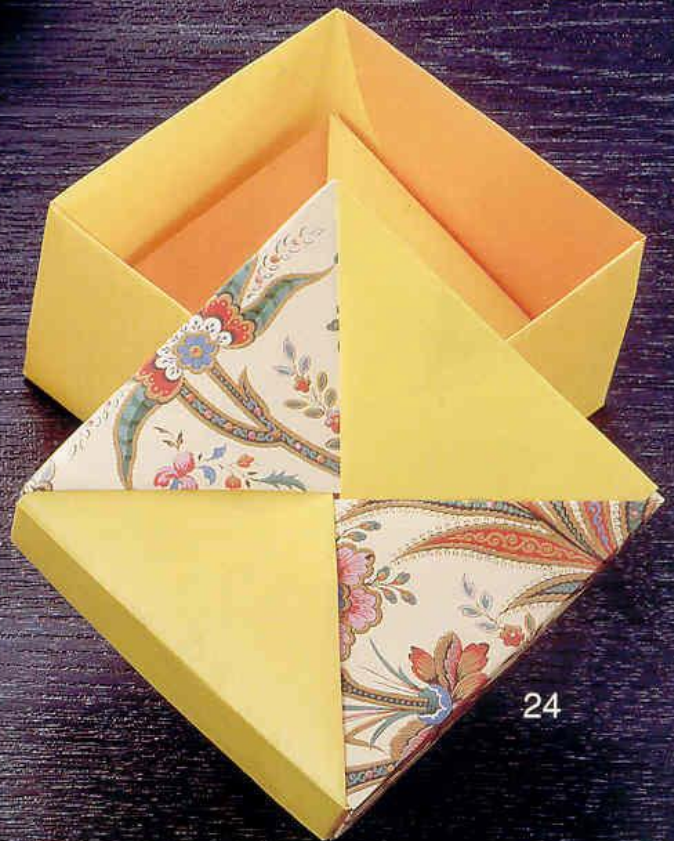

24

26



27

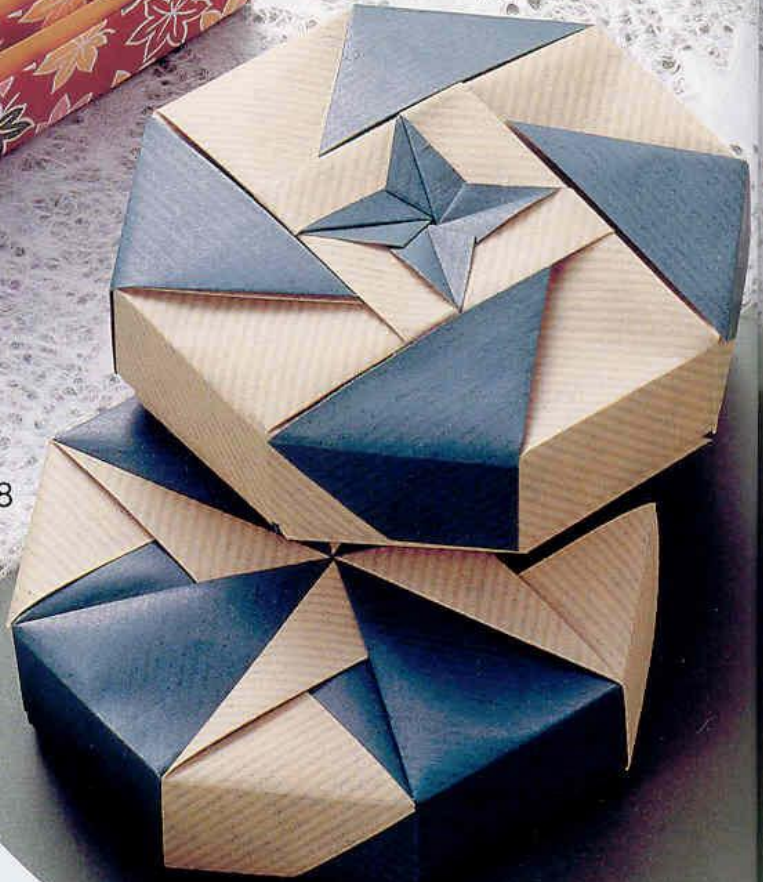

28



29





33

31

32

30



34



35



36

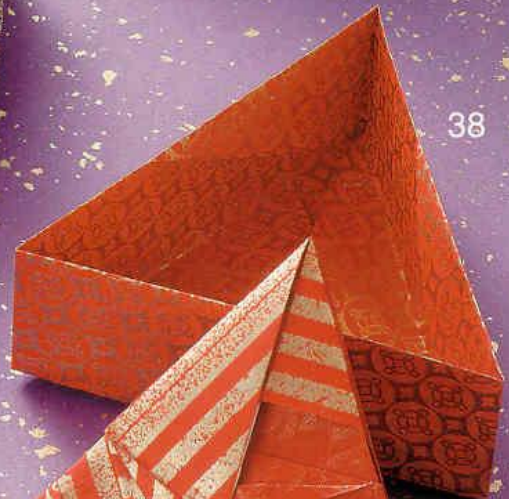

38



37



39

Symbols

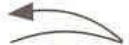
 Crease then open again.

 Turn over.

 Enlargement

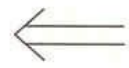
 Pull out.

 Rotate.
The next drawing shows a different position.

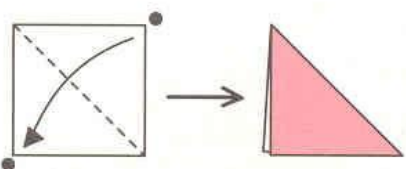

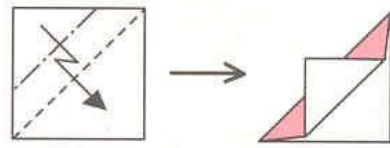
Fold so that the points indicated by the dots meet.

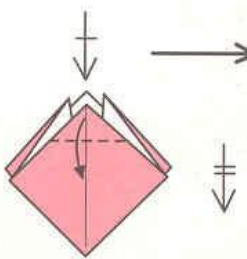

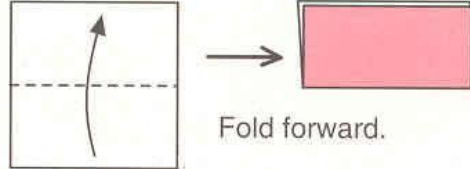
Pleat.

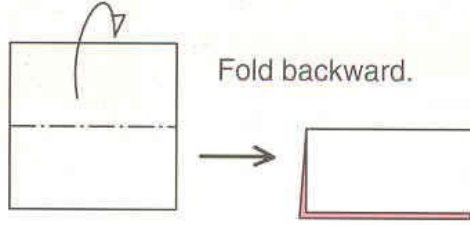

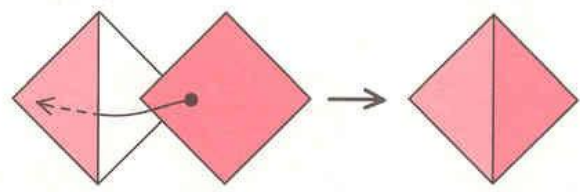
Repeat the fold behind, the same as the one shown in front.
Repeat 2 times.

Valley fold

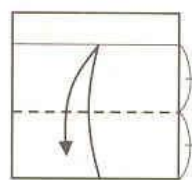
Fold forward.

Mountain fold

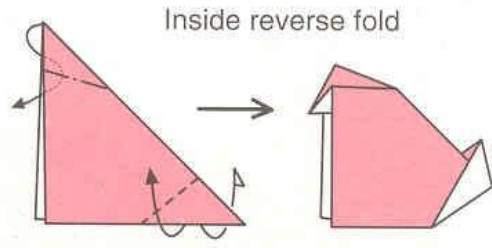
Fold backward.

Insert into pocket.

Equal Lengths

Inside reverse fold

Outside reverse fold

Party Plate (1) from a square

◆ PLATE 1 ◆

Place a piece of paper (inside liner) inside the plate to keep the shape.

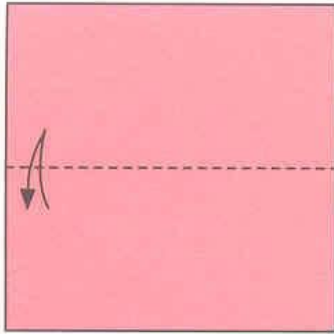
①



②

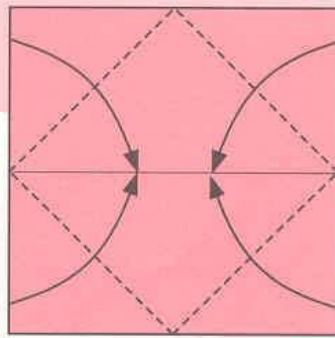

③

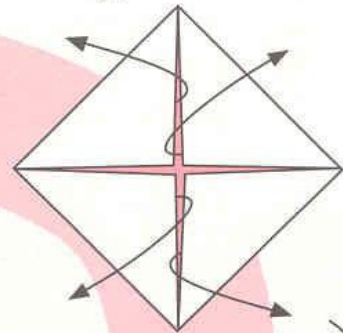

Unfold and turn over.



④

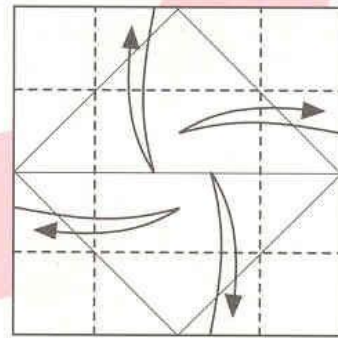

Make creases.

⑤

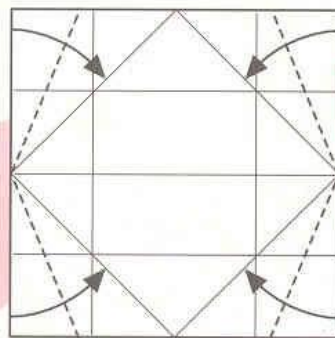

⑥

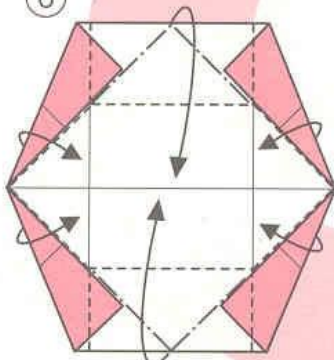

Bring the top and bottom edges to the center, folding the four corners.

⑦

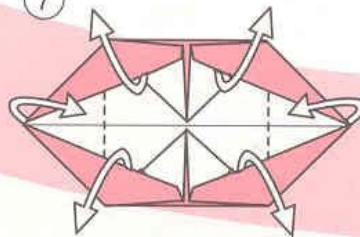

Lift up the rims.

⑧



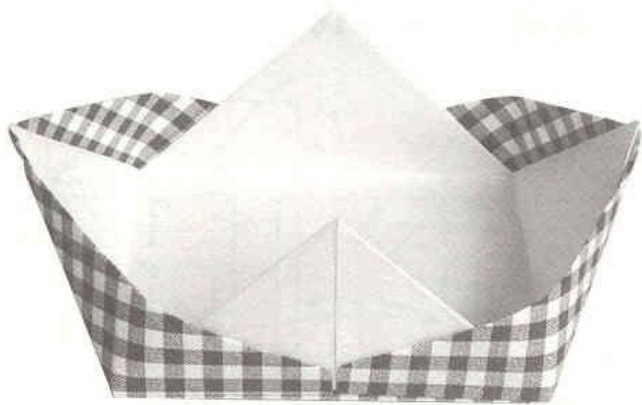

◆ INSIDE LINER ◆

①

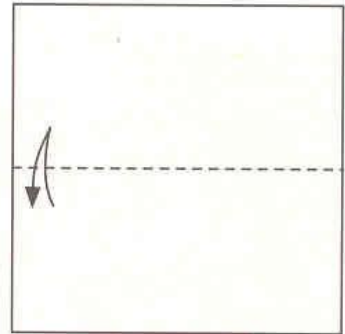

②

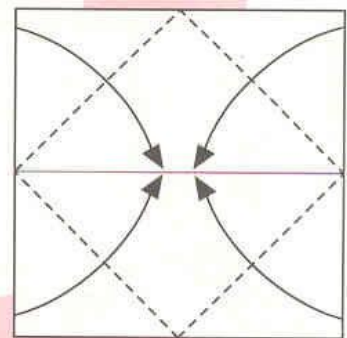

④

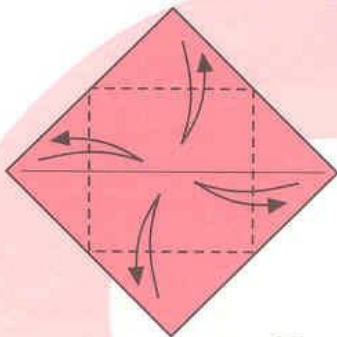

Place the liner
inside the plate.

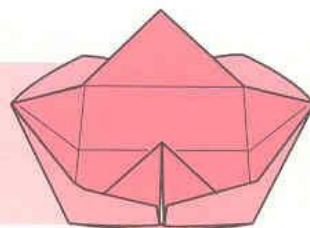
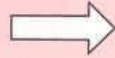
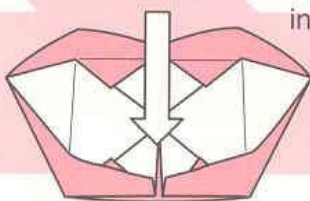
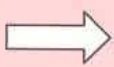

③

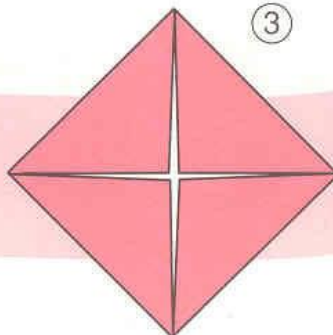

Party Plate (2) from a square

◆ PLATE 2 ◆

A plate with pleats. Place a inside liner inside to keep the shape.

①

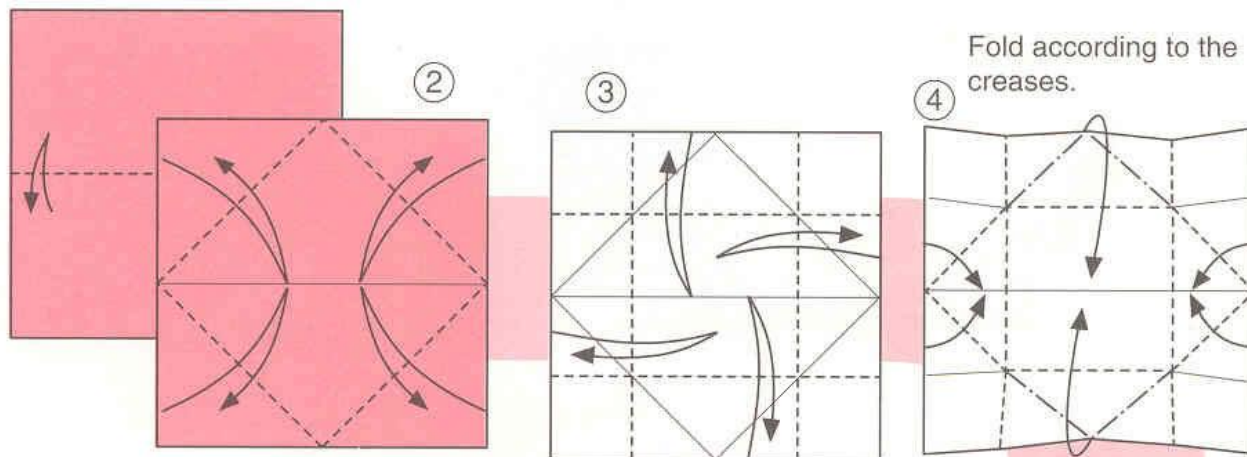

Fold according to the creases.

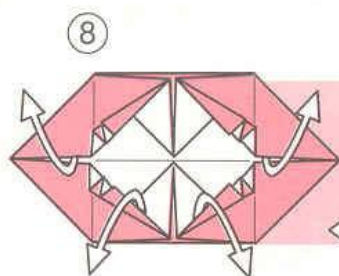

Lift up the rims.

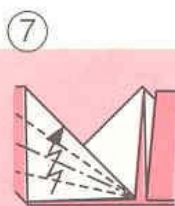

Make pleats.

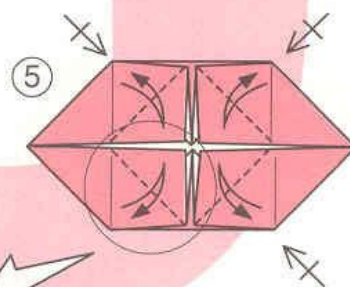
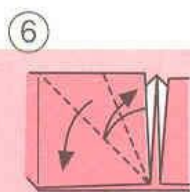

Inside liner on page 17.

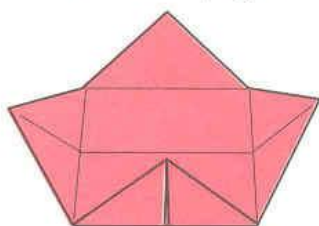

Place the liner inside the plate.

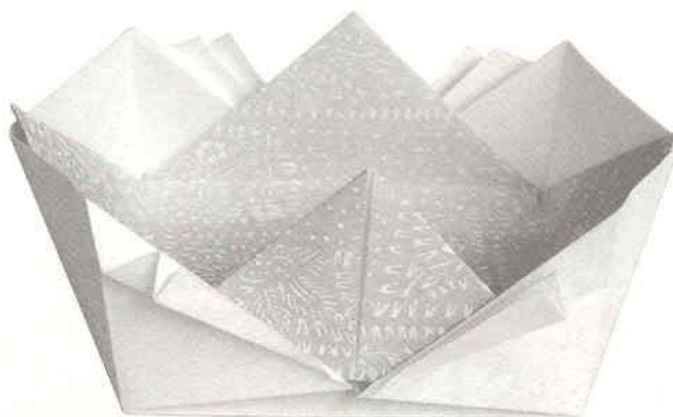
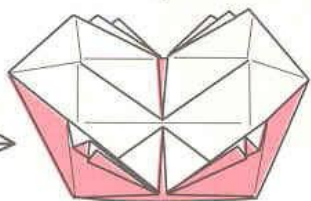

Party Plate (3) from a square

◆ PLATE 3 ◆

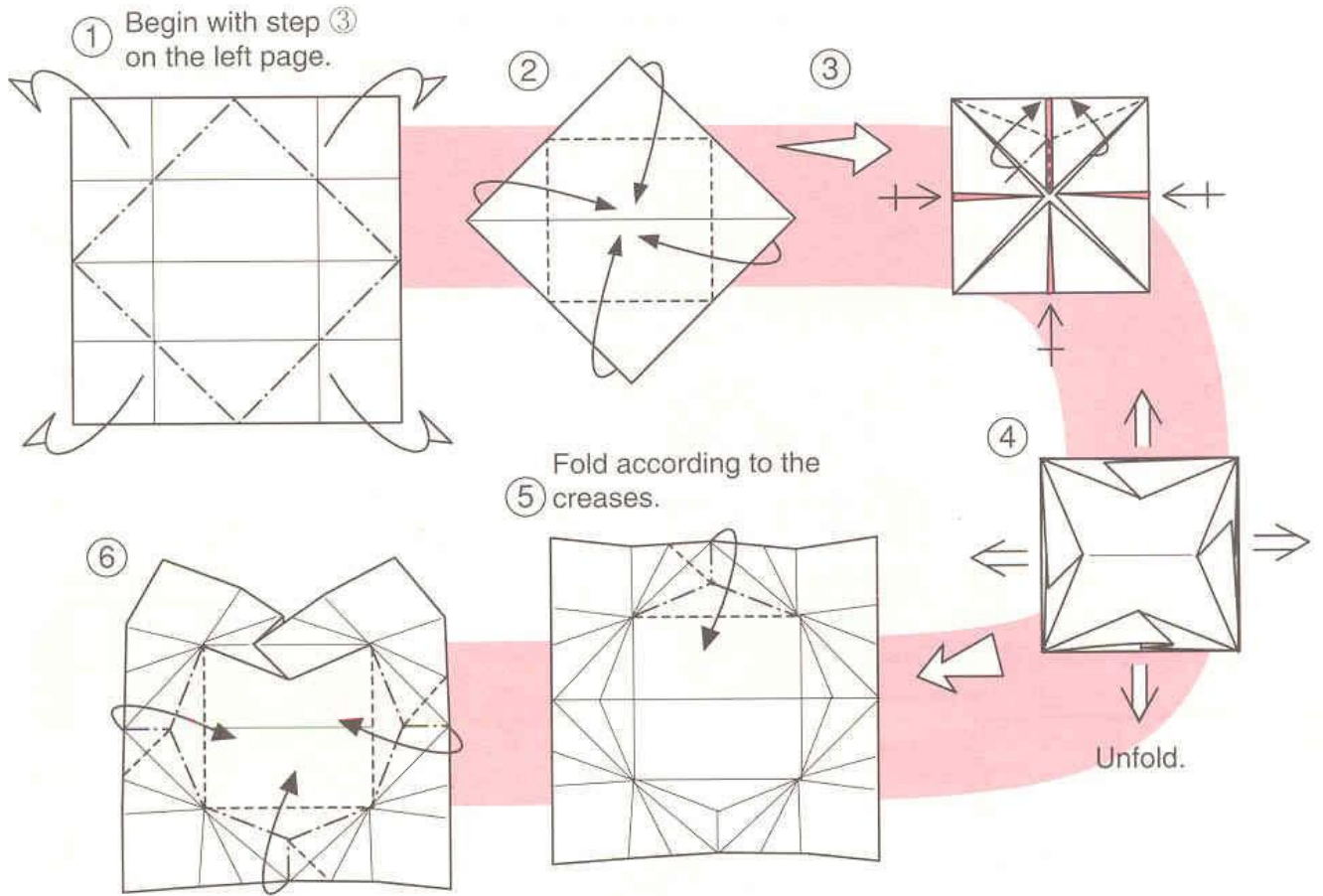

Fold other three parts in the same way as step ⑤, and lift up the rims.

Inside liner on page 17.

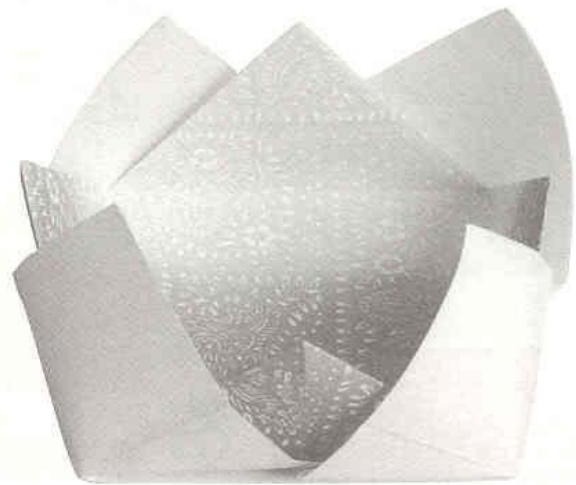
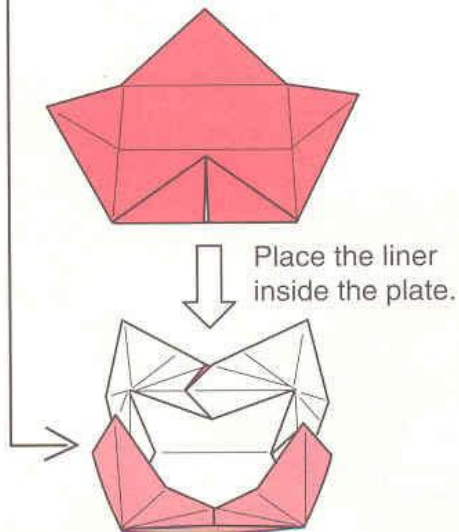

Party Plate (4) from a rectangle

◆ PLATE 4 ◆

Rectangle paper is used here. For the inside liner use the paper of the same size.

You may also use a paper napkin or other paper you like.

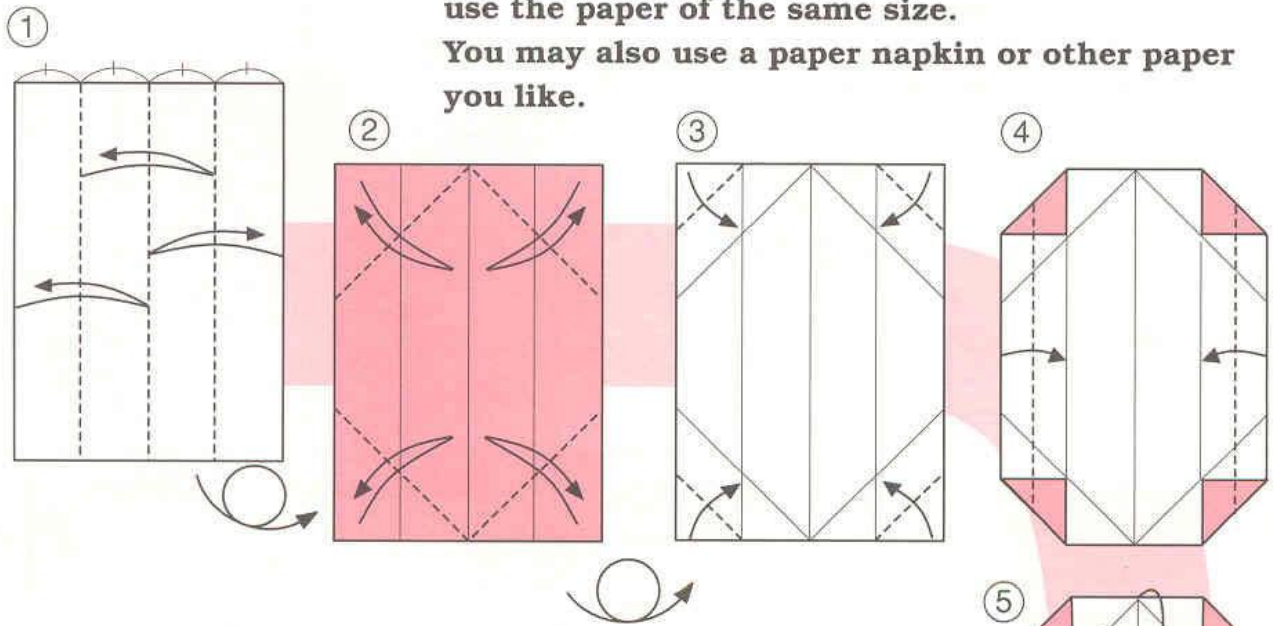

◆ INSIDE LINER 1 ◆

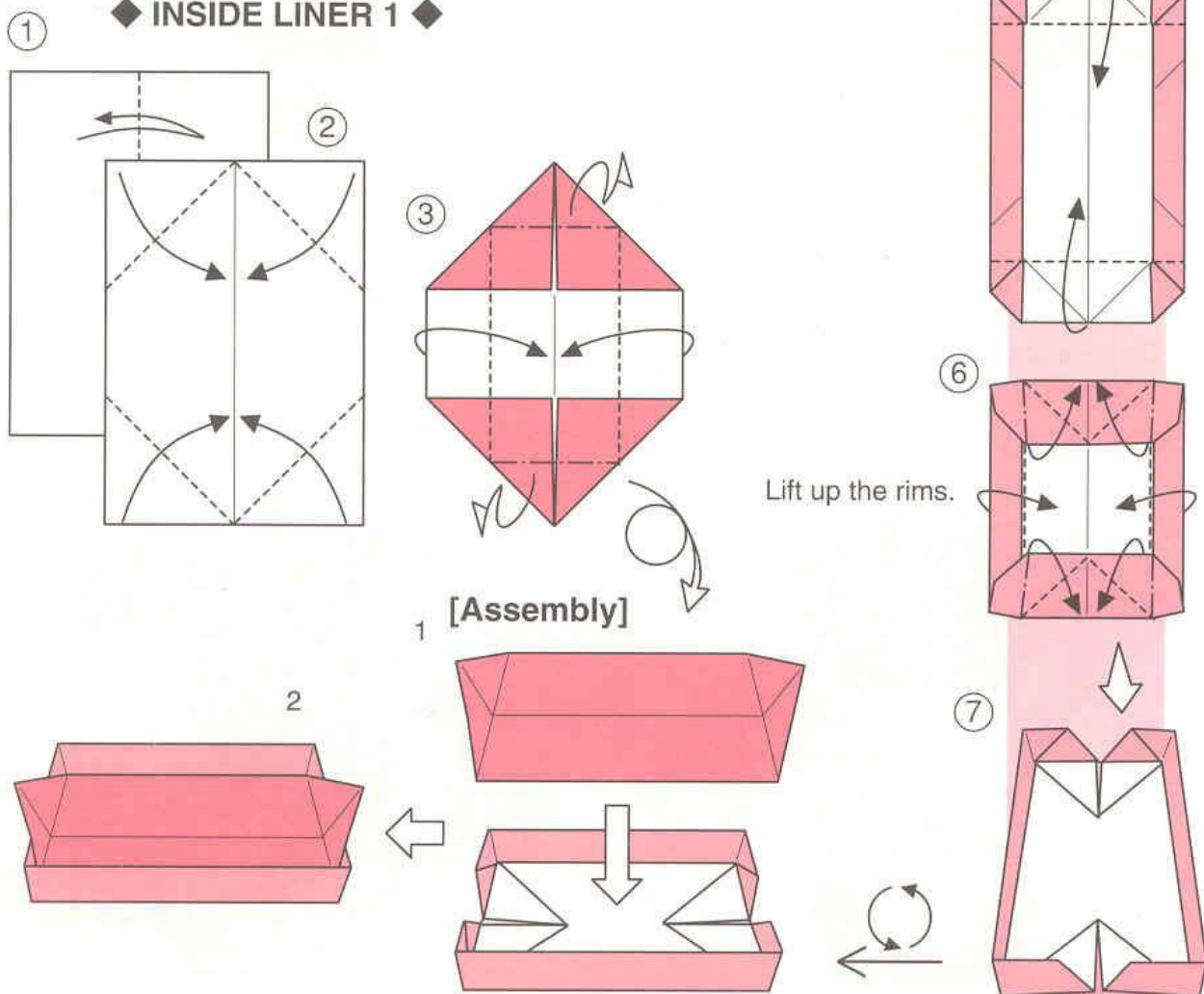

Place the inside liner inside the plate.

◆ INSIDE LINER 2 ◆

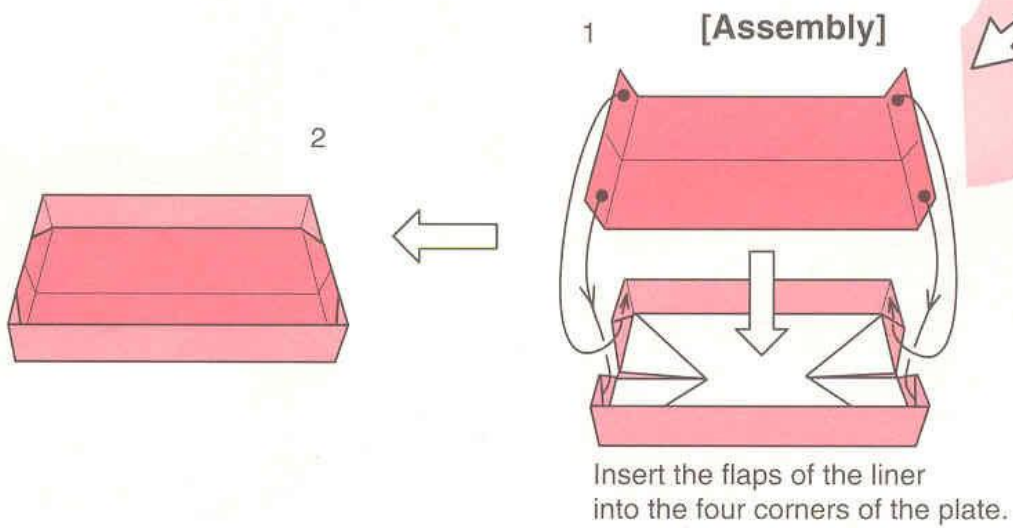
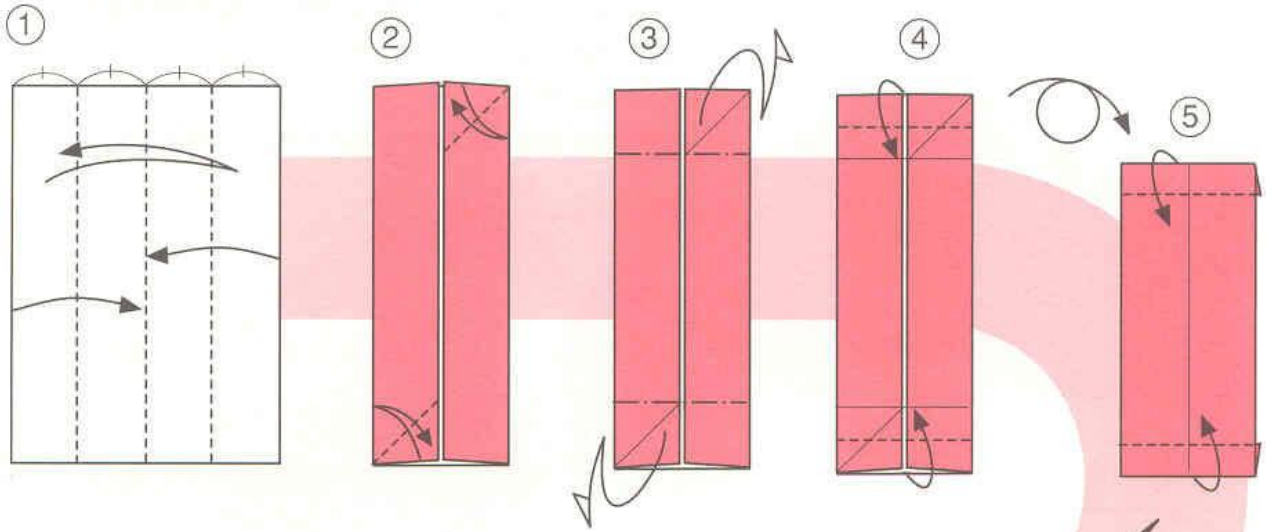

With Inside Liner 1

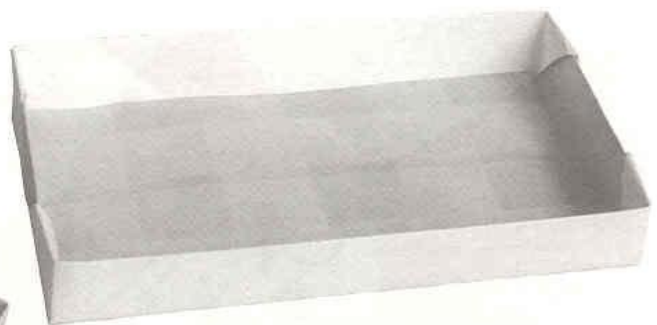

With Inside Liner 2

Triangle Box (A)

This triangle box is easier to fold than conventional ones and yields many variations.

Nesting boxes are also easily made.

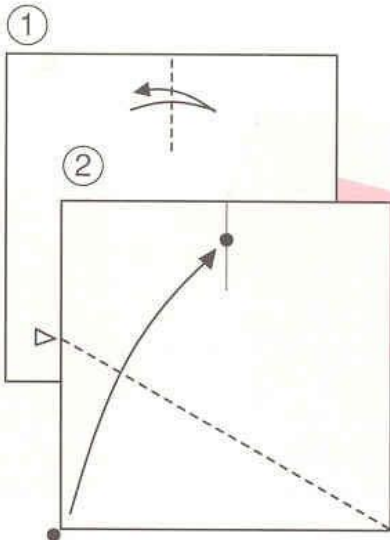

Using Δ as a pivot, fold \bullet to \bullet .

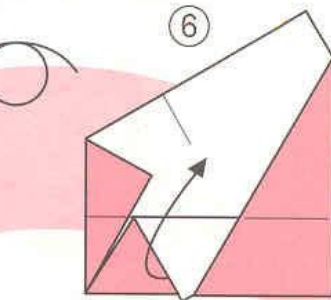
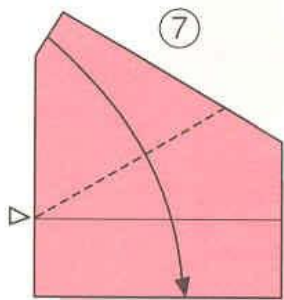
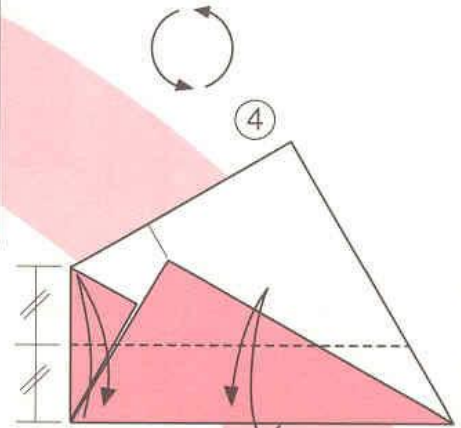
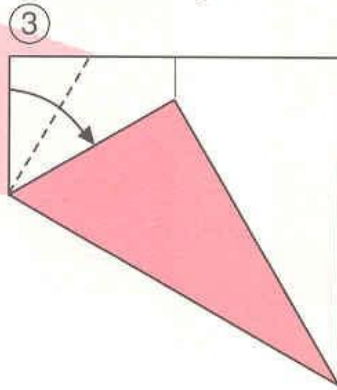

Unfold the inside triangle.

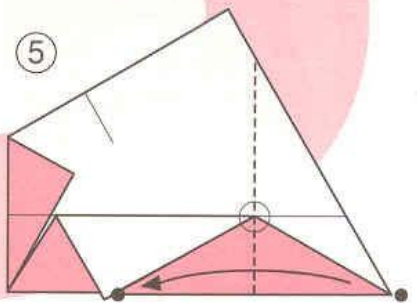

Fold at \circ so that \bullet meets.

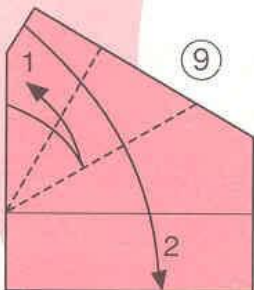
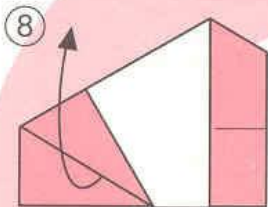

Fold in numerical order.

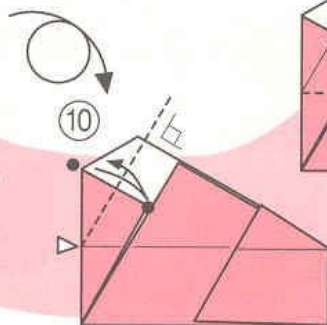

Using Δ as a pivot, fold \bullet to \bullet .

Lift up the side and fold the upper layer to make the bottom.

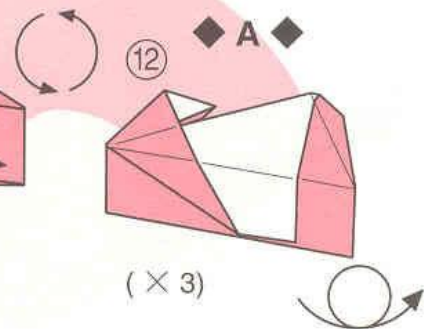
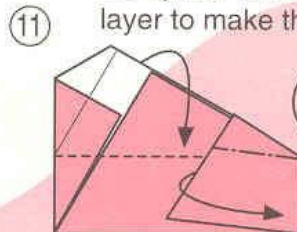

($\times 3$)

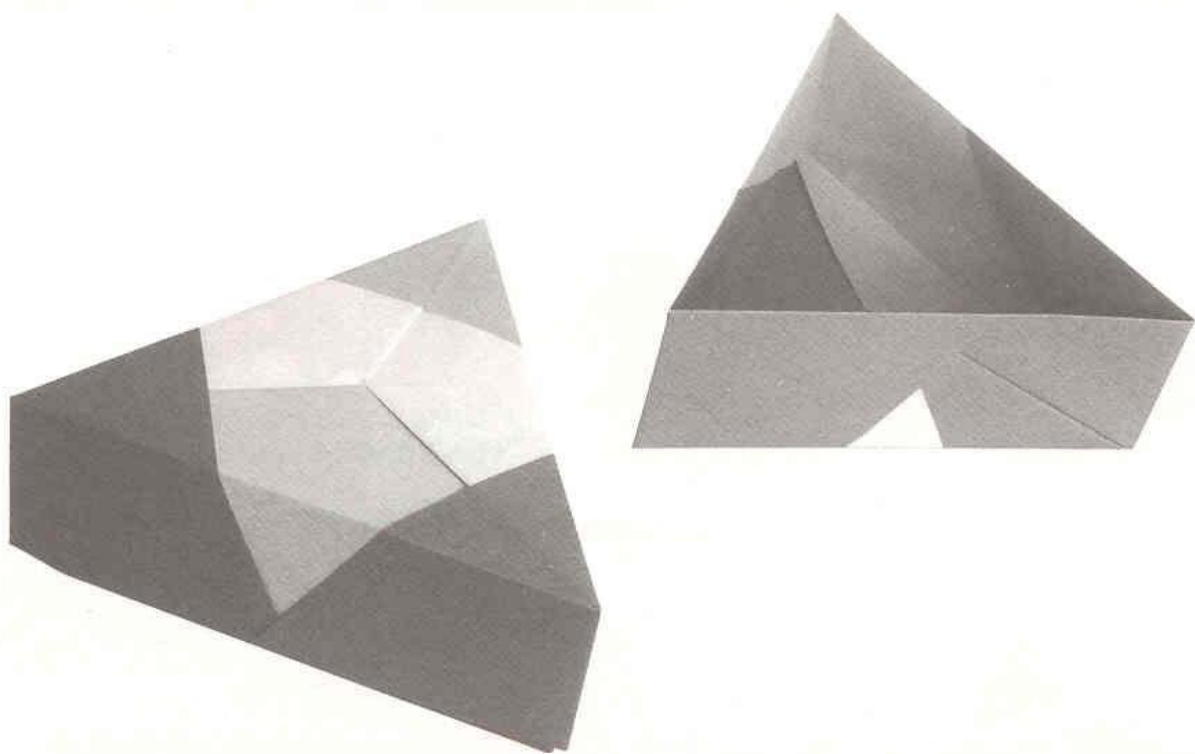

(Outside)

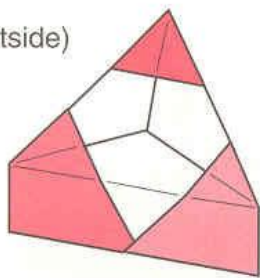

(Inside)

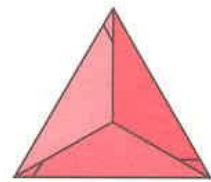
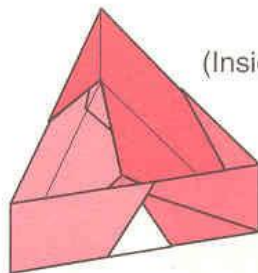

The inside seen from above.

[Assembly]

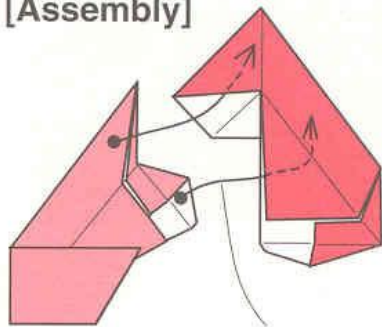

Insert between the flaps and tuck point into the pocket.

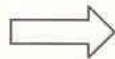

Insert the flaps marked * from under and tuck points into the pockets.

Triangle Box (B)

◆ B ◆

Begin with step ⑧ of A.

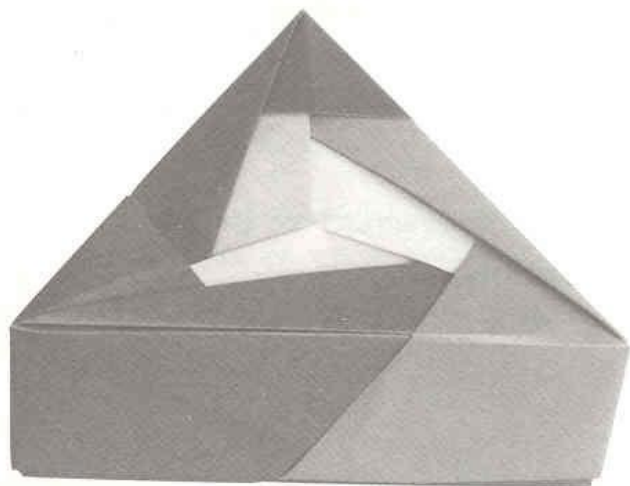
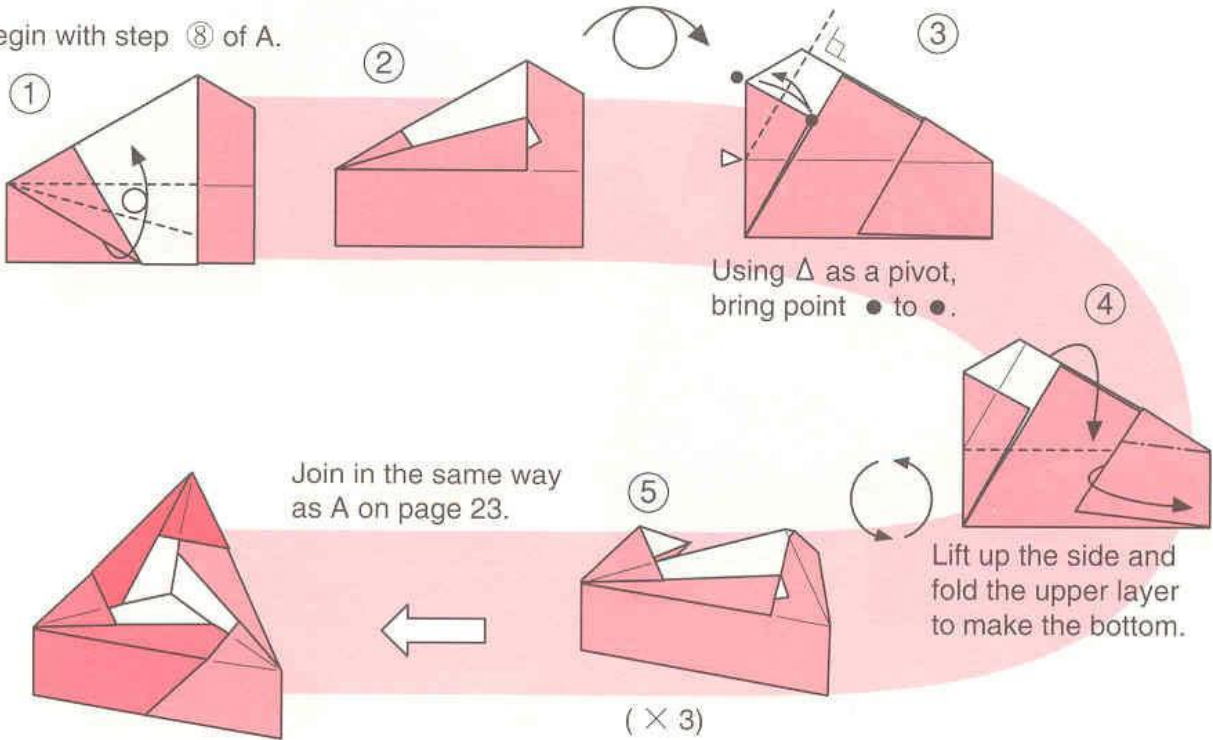

Triangle Box (C, D)

Begin with step ⑧ of A.

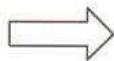
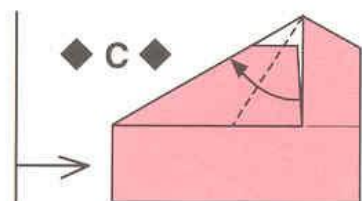
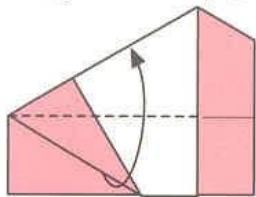

Make this crease after the units are joined.

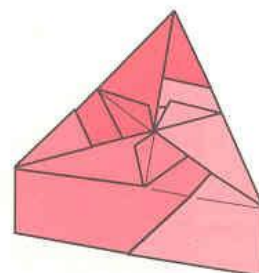
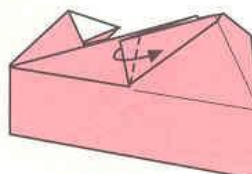

Fold and join in the same way as A, beginning with ⑩.

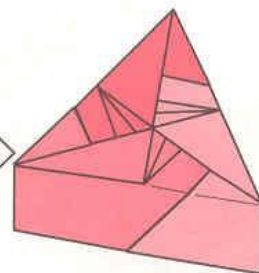
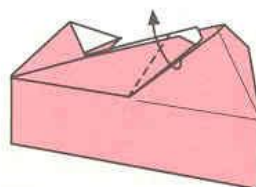
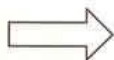
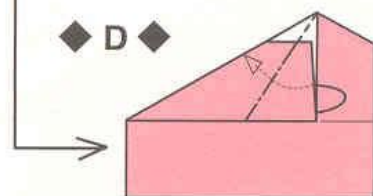

Make this crease after the units are joined.

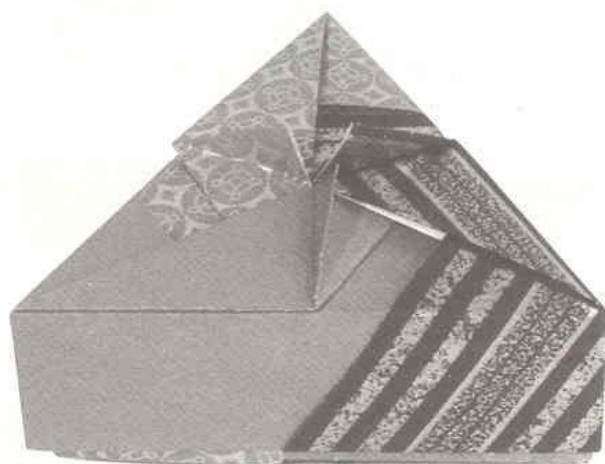

(C)



(D)

Triangle Boxes *Body & Nesting Boxes*

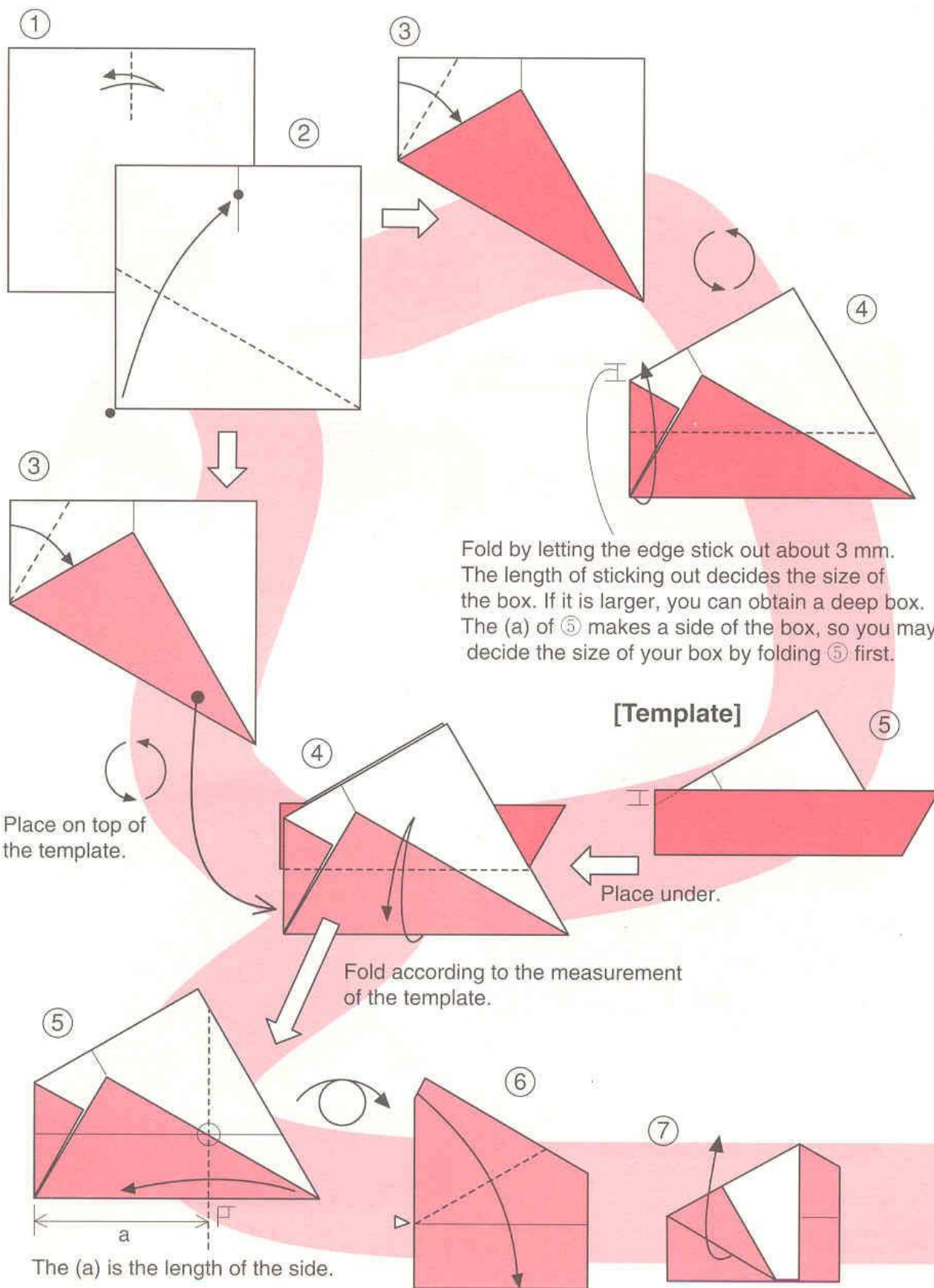

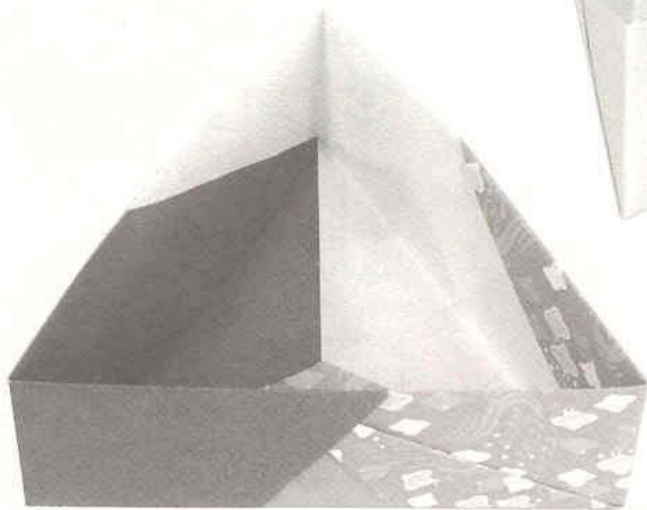

Triangle Box - Body

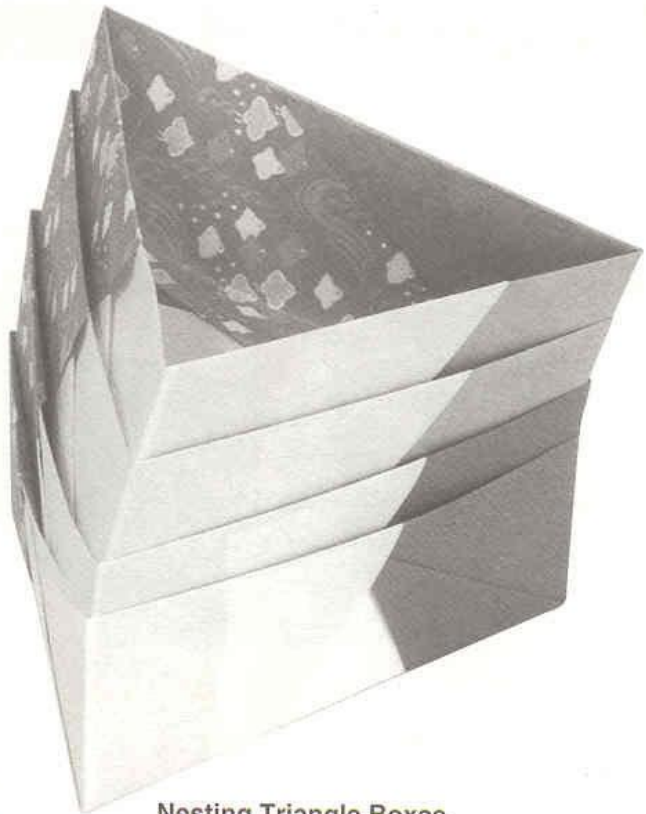

Nesting Triangle Boxes

Join in the same way
as A on page 23.

Make B, C, D
in the same way.

⑧

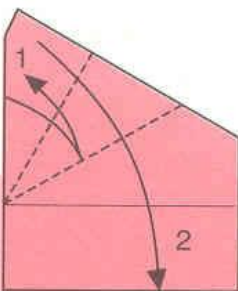

Fold in numerical order.

⑨

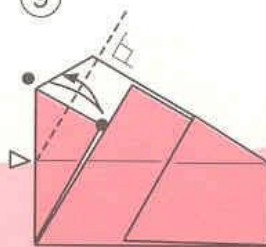

Using Δ as a pivot,
fold ● to ●.

⑩

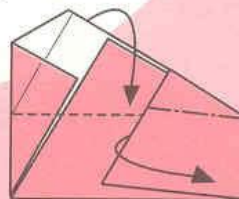

Lift up the side and fold
the upper layer to make the bottom.

⑪



(× 3)

Hexagon Box (A)

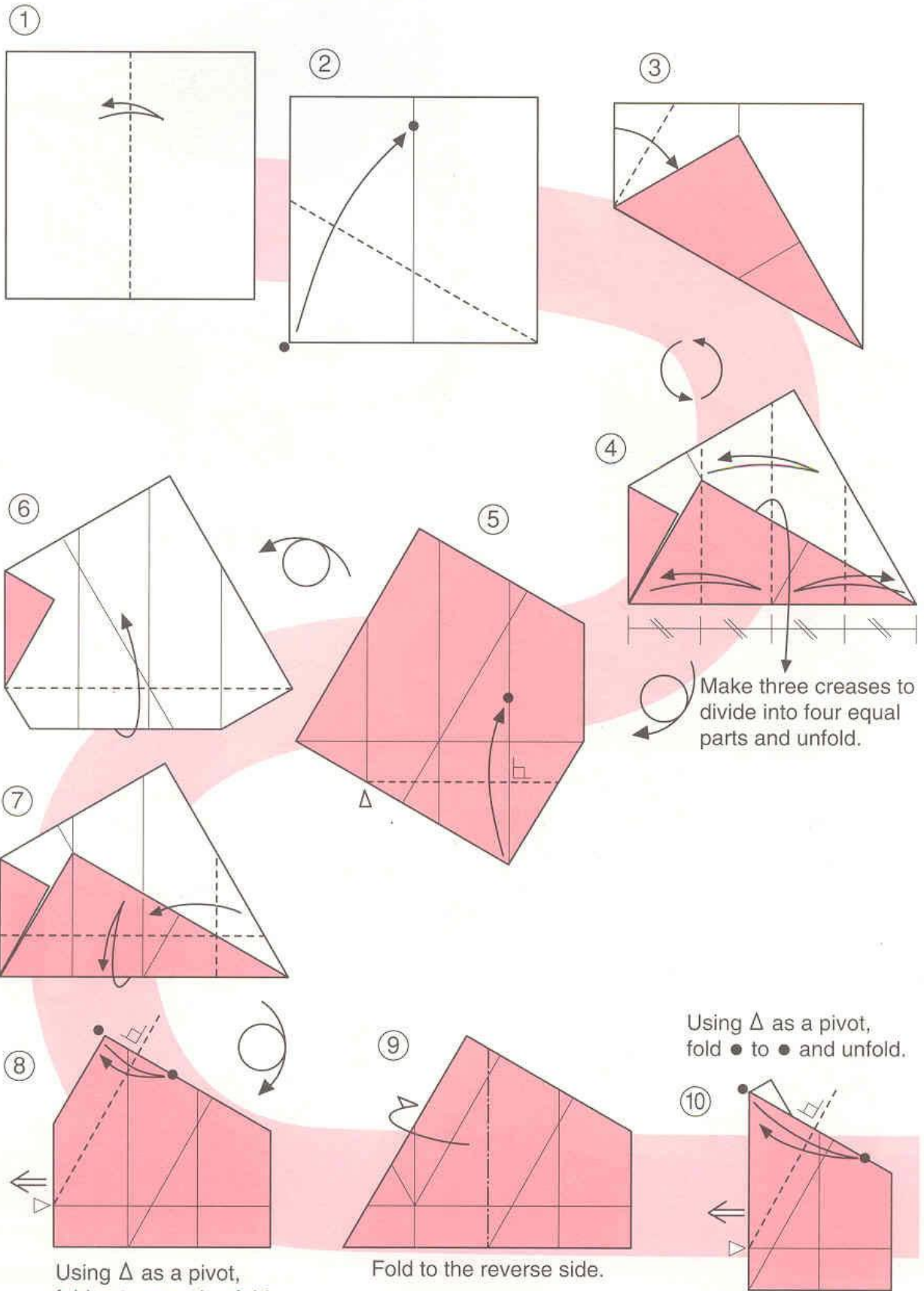



You may use it as it is,
or lift up tops.

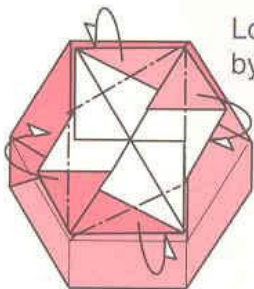
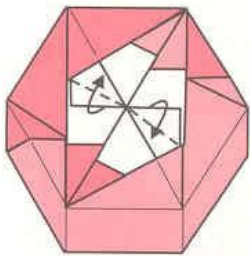

Lock each point
by folding it inward.

(Inside)

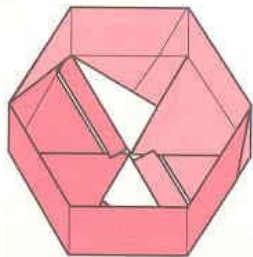

[Assembly]

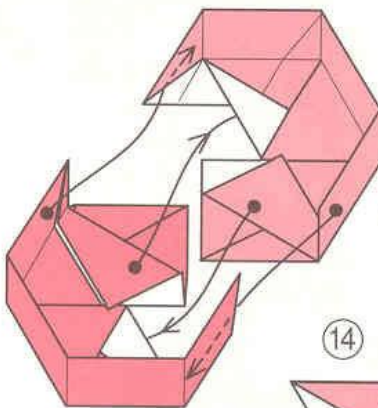

(× 2)

⑭

Fold in pleats.

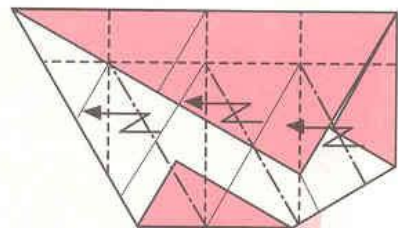

⑪

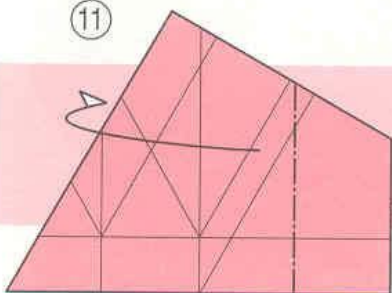

⑫

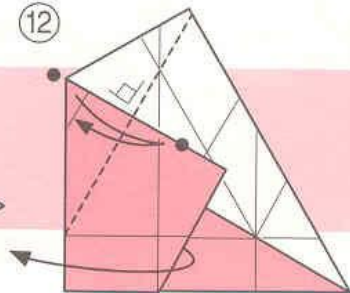

⑬

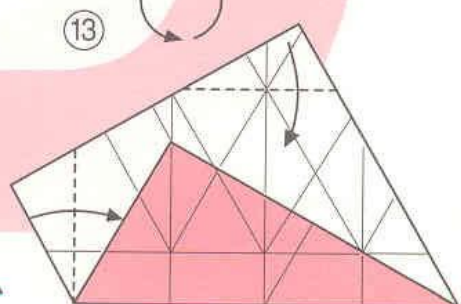

Hexagon Box (B)

Begin with step ⑬ on page 29.

Try different folding other than those introduced here.

You can have various patterns.

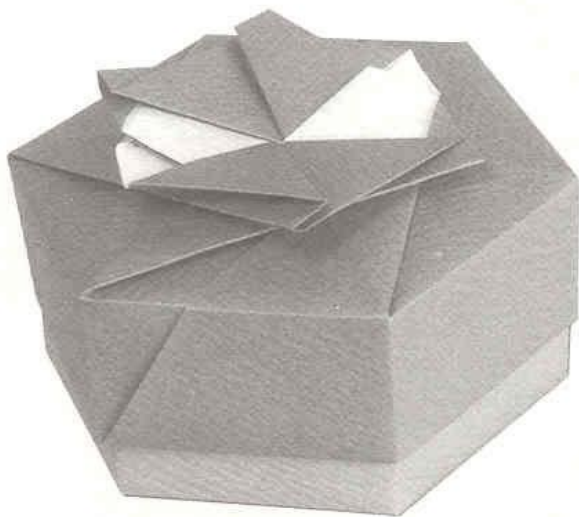
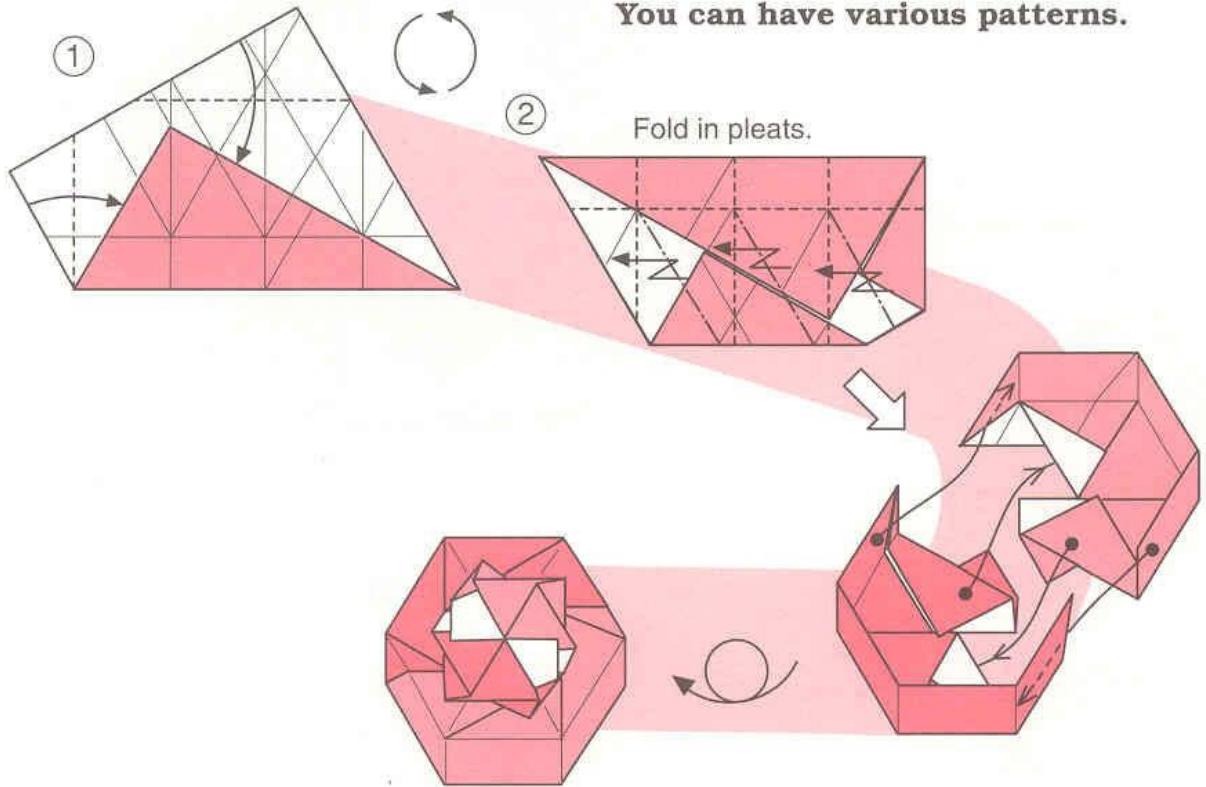

Hexagon Box (C)

Begin with step ④ on page 28.

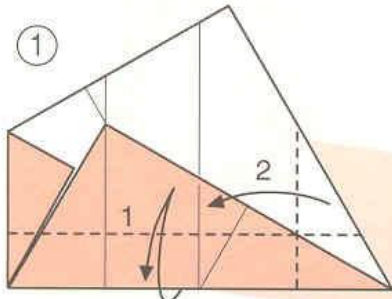

Fold in numerical order.

Using Δ as a pivot, fold \bullet to \bullet and unfold.

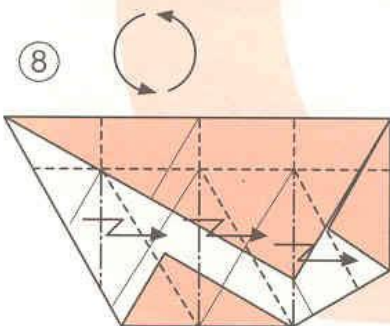
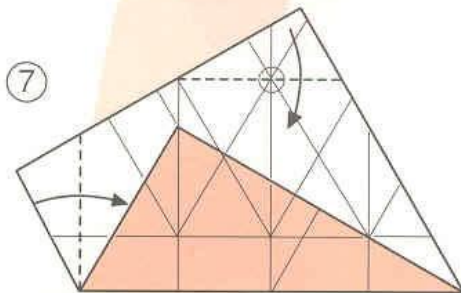
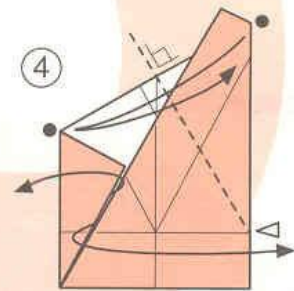
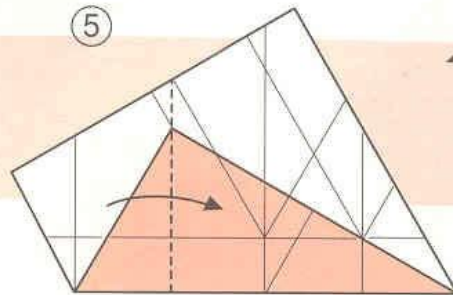
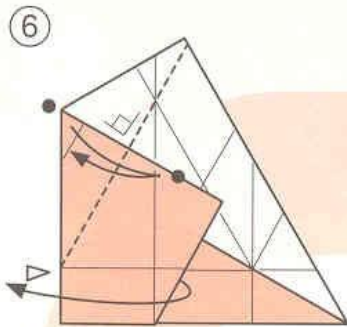
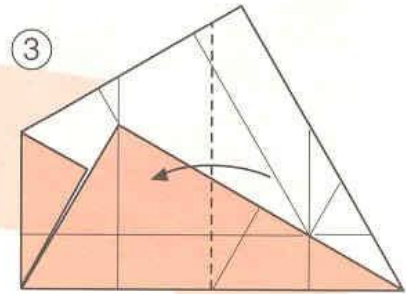
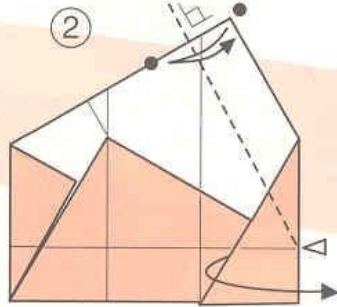

Fold in pleats.

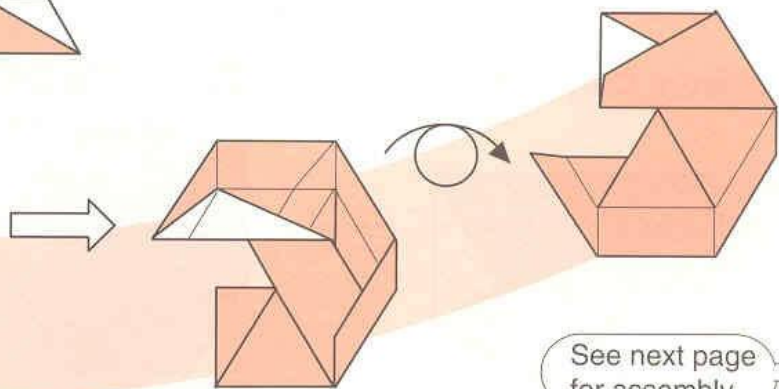

See next page for assembly.

[Assembly 1]

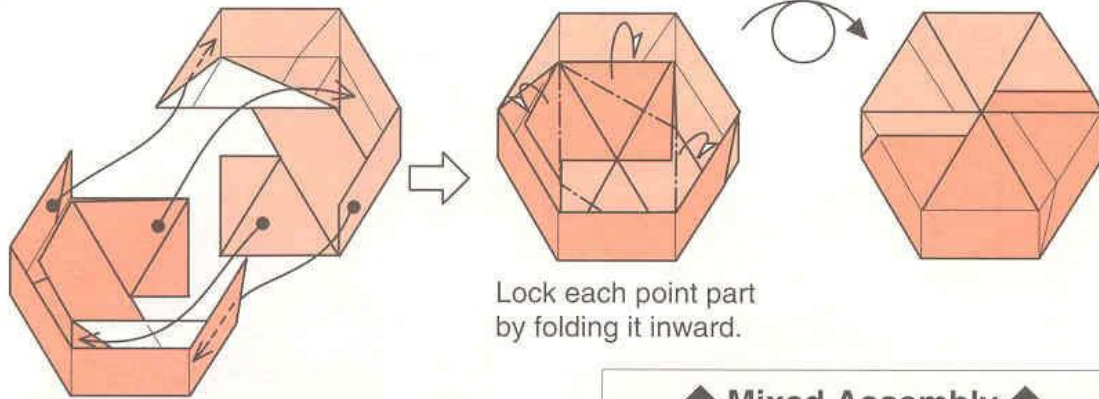

Lock each point part by folding it inward.

◆ **Mixed Assembly** ◆

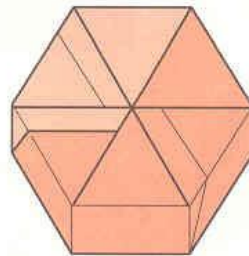

Insert into the left and right of a unit.

[Assembly 2]

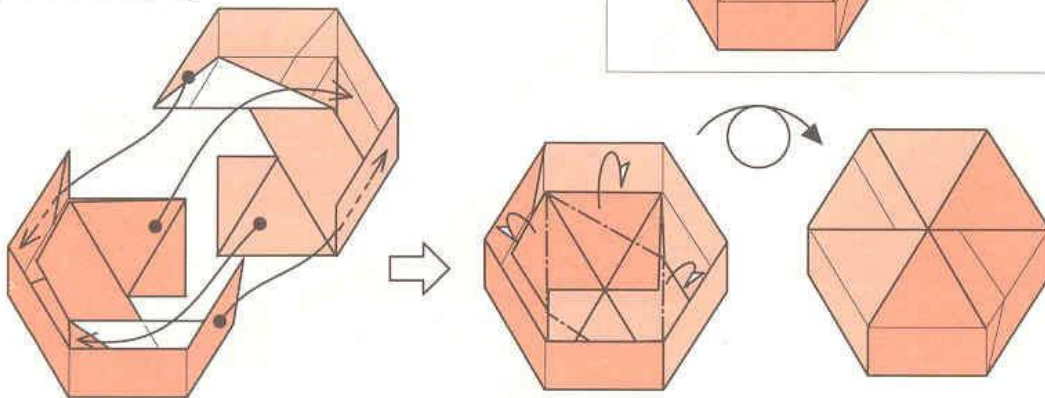

◆ **Different Colors** ◆

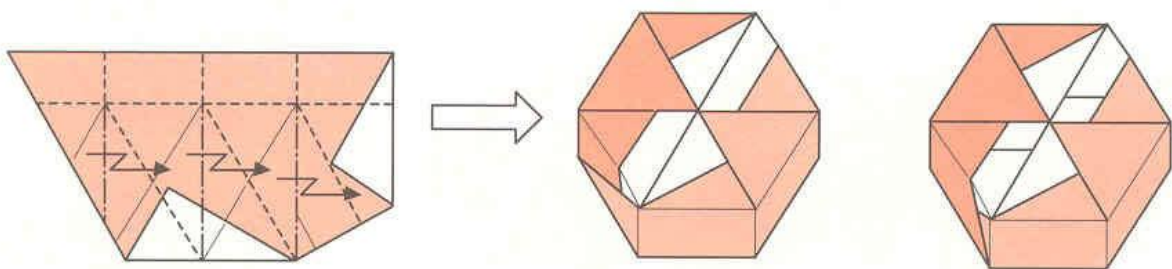



[Assembly 1]



[Mixed Assembly]

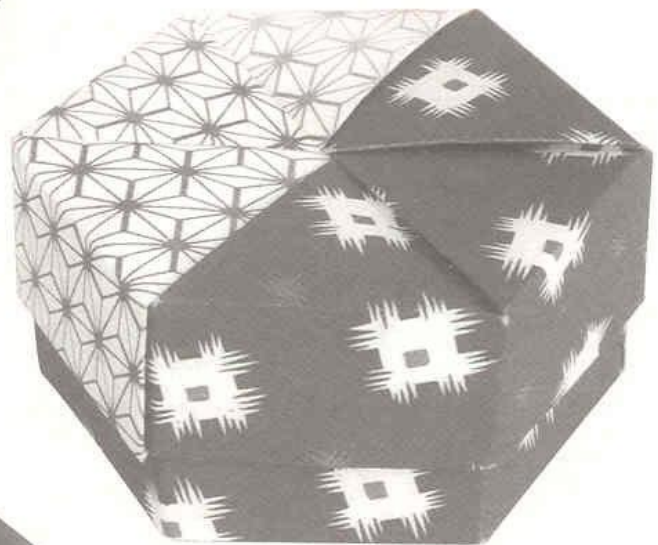

[Assembly 2]

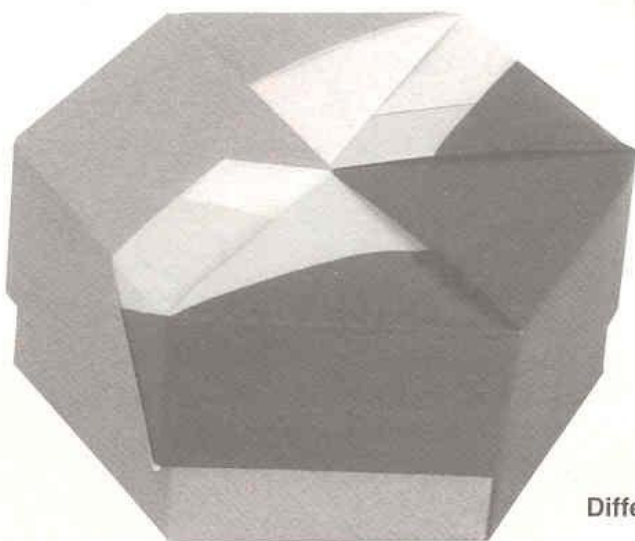

Different Colors [Assembly 2]

Hexagon Boxes *Body & Nesting Boxes*

Begin with step ④ on page 28.

Take the measurements in the same way as for an octagonal box. If you change the width of ①, you can make nesting boxes.

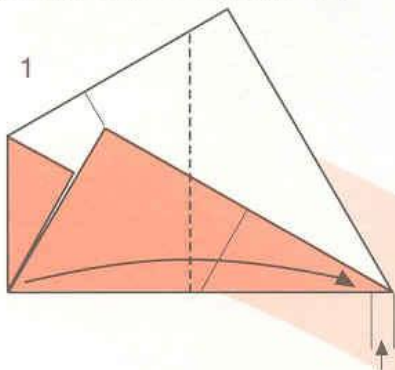

When using 15 cm square paper, fold the left edge 3 to 4 mm away from the right corner.

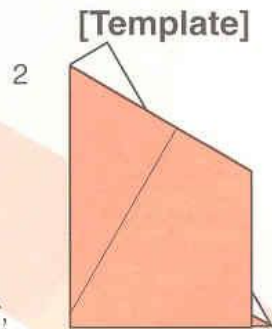

Place under.

Place another ① on top of the template and take the measurements.

After making a crease, unfold.

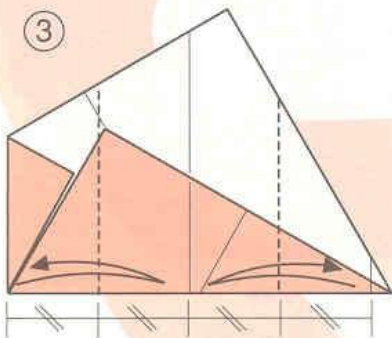
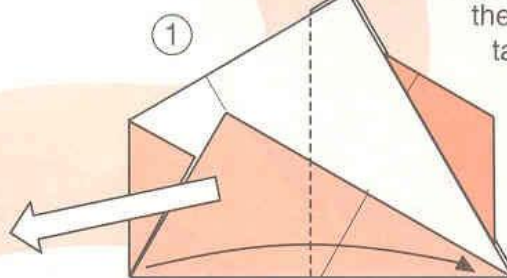
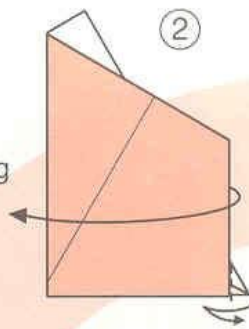

◆ Shallow ◆

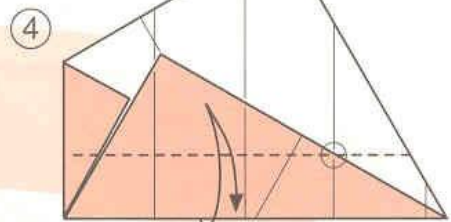

◆ Deep ◆

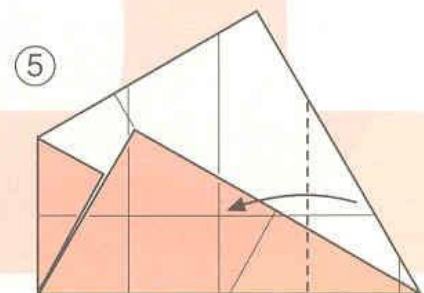
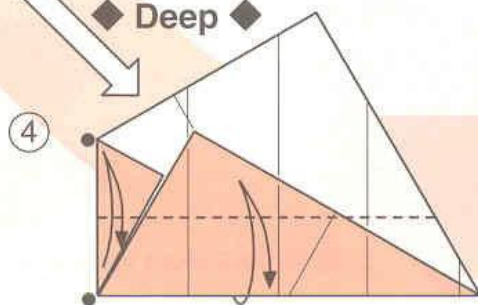

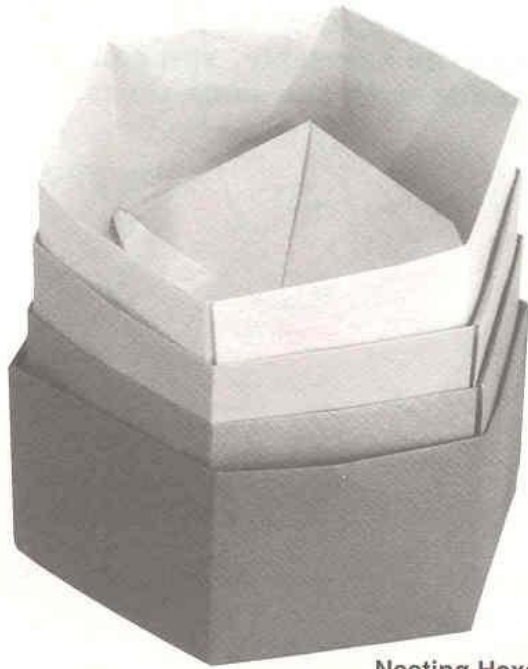

Nesting Hexagon Boxes

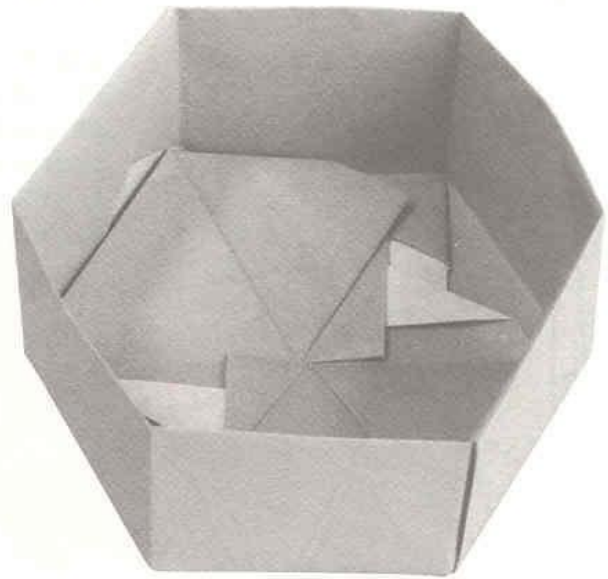

Hexagon Box - Body

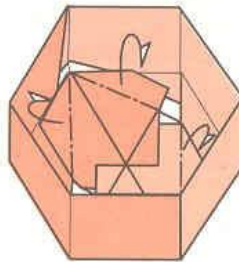
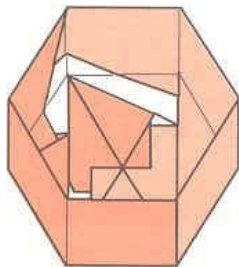

Lock by folding each flap to the reverse side.

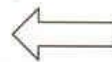

See [Assembly 2] on page 32 for the assembly.

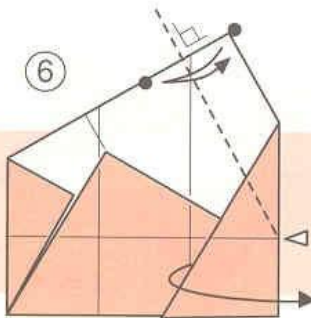
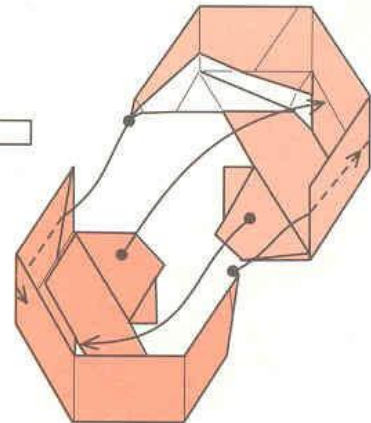

Continue with the same steps from ③ on page 31.

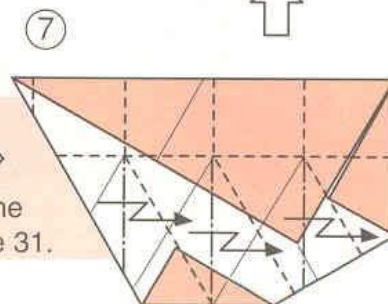

Square Boxes from a Rectangle

The standard size of paper is a quarter of $210 \times 300\text{mm}$ ($8 \frac{1}{4} \times 11 \frac{3}{4}$ ").

Use rectangle paper. Since the ratio between the lengths of sides is variable as long as not extreme, you may use any paper at hand. If you change the assembly, you can get different results with the same units.

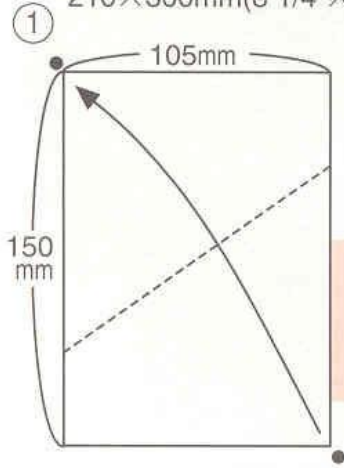

The ratio of lengths of sides is 1 to 1.4.

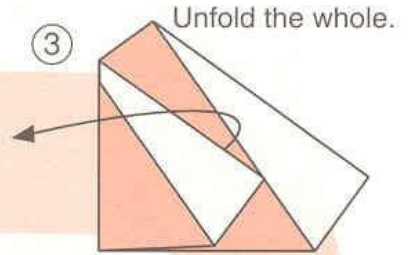
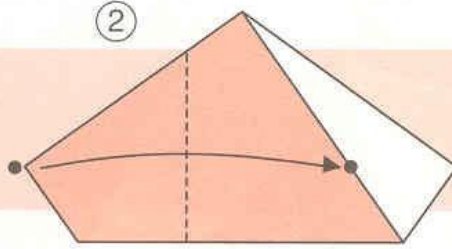

Unfold the whole.

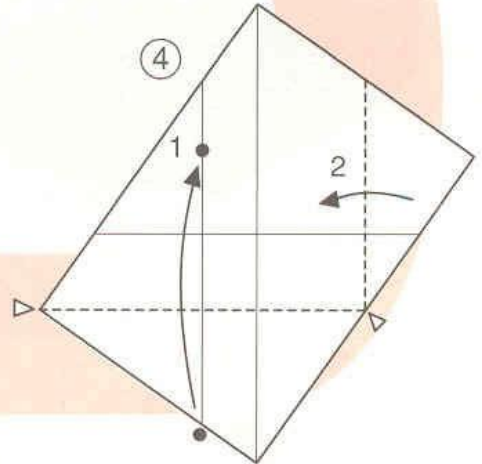
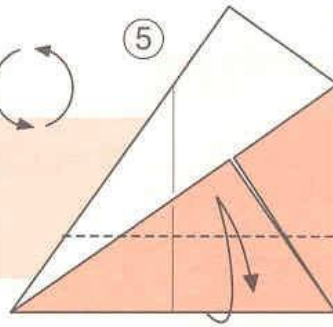
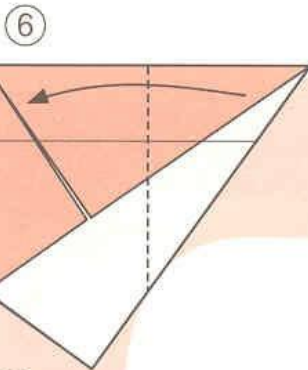

Using Δ as a pivot, fold \bullet to \bullet .

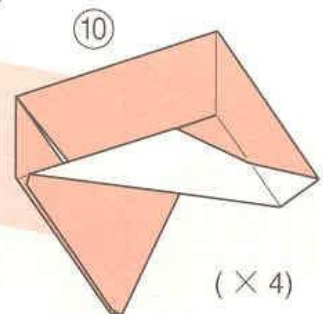
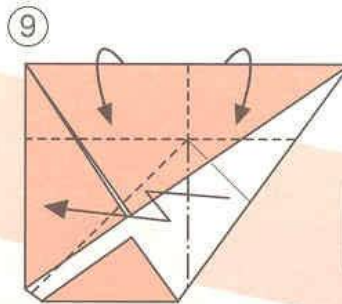
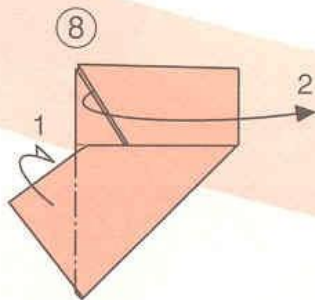
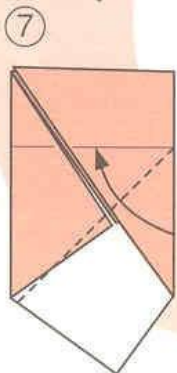

($\times 4$)

◆ Bowknot ◆

[Assembly]

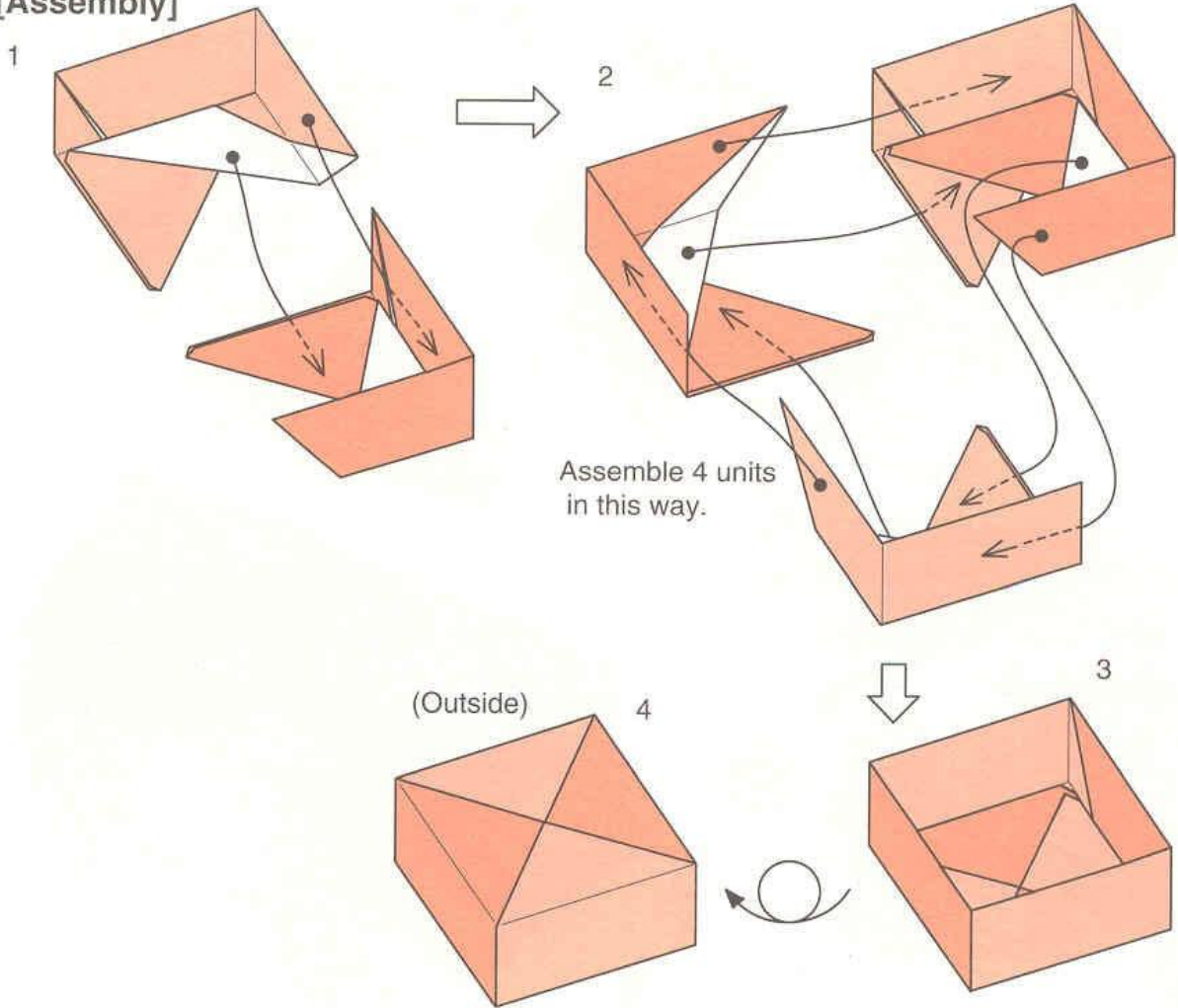

◆ Different Patterns · Windmill ◆

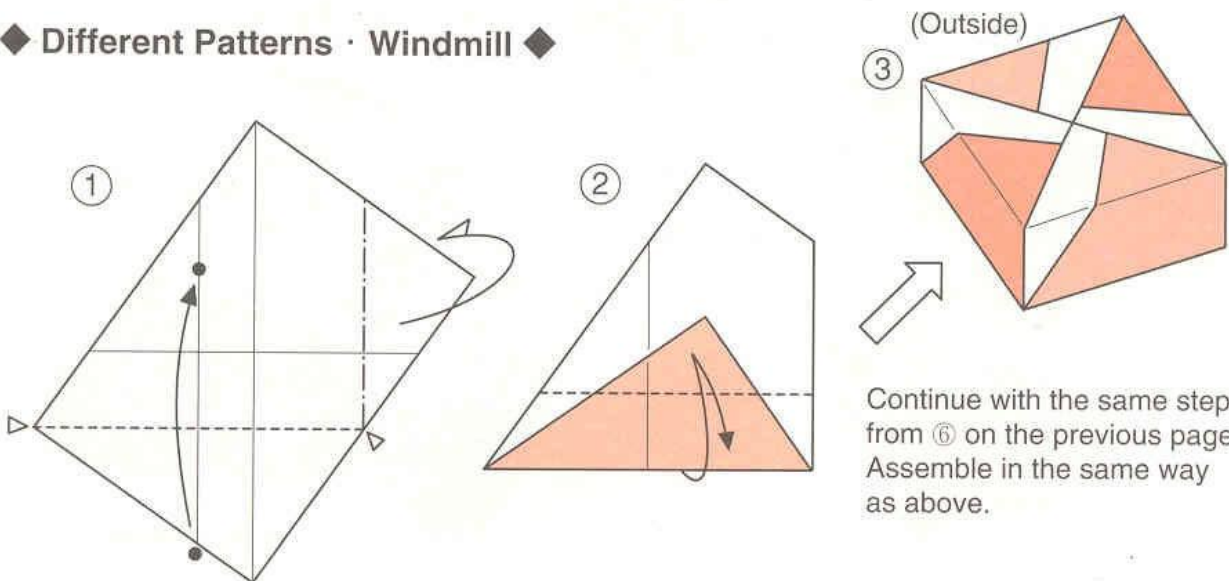

◆ Tomoe ◆

[Assembly]

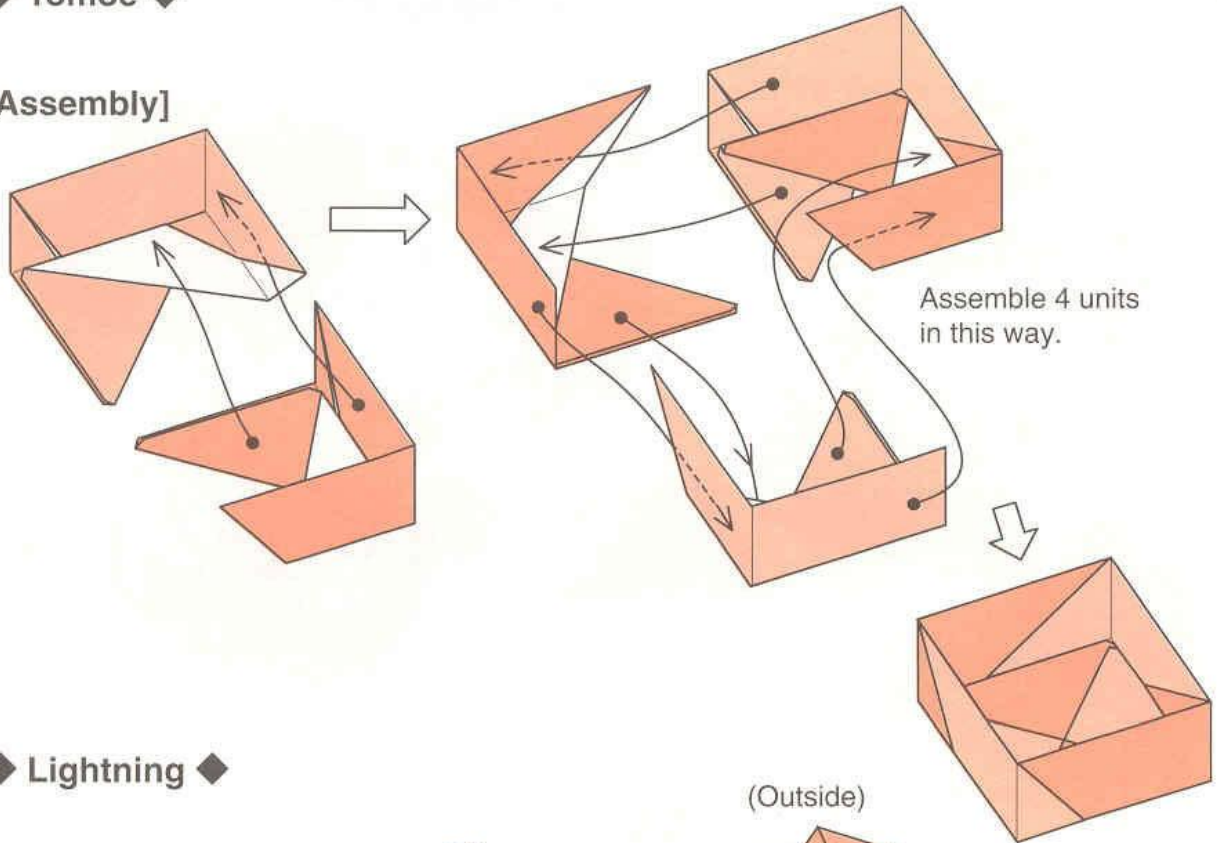

◆ Lightning ◆

[Assembly]

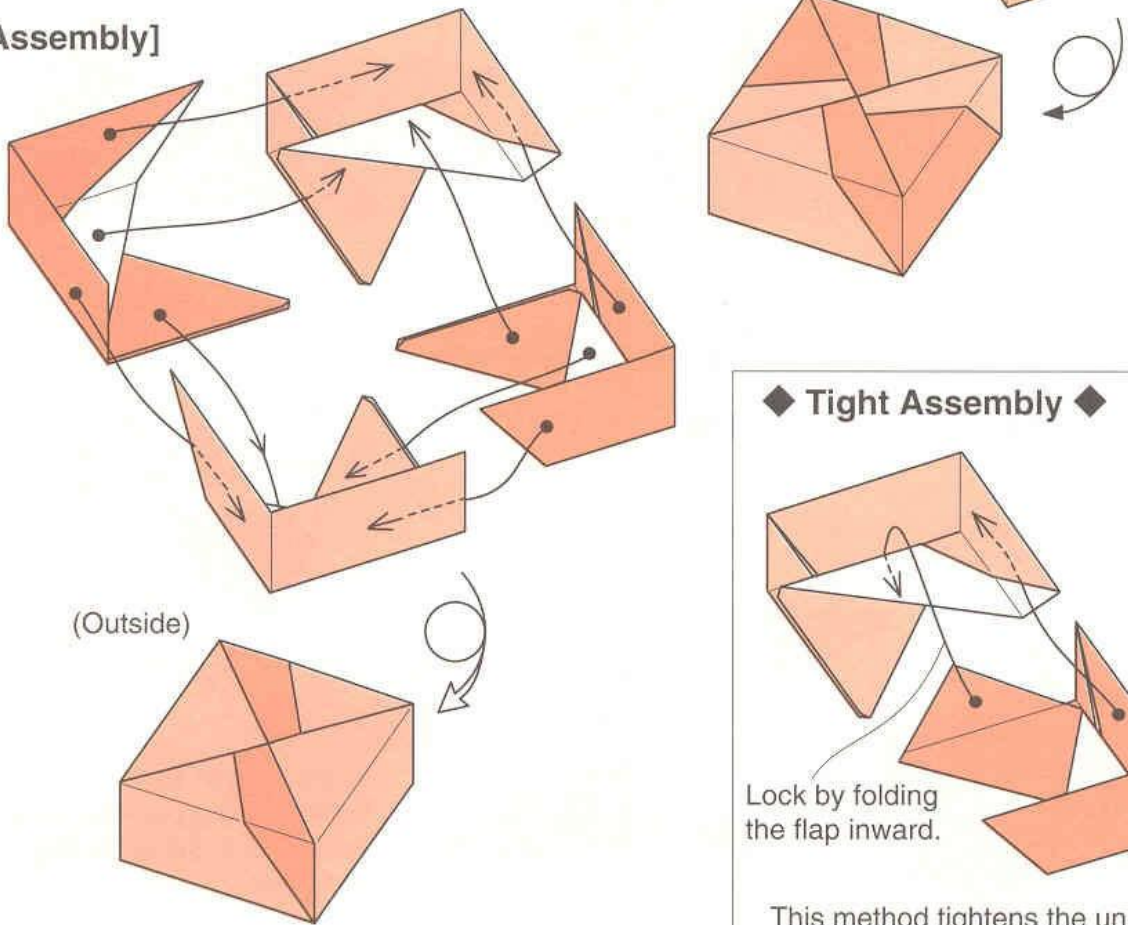

◆ Tight Assembly ◆

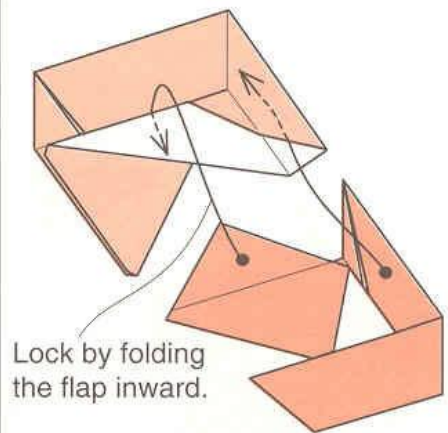

If you mix the assembly of "bowknot" and "tomoe,"
you can obtain more different patterns.

◆ Examples of Mixed Assembly ◆

A

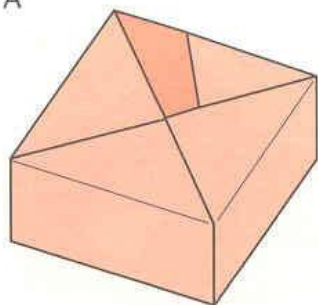

B

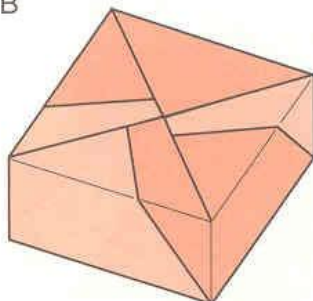

C

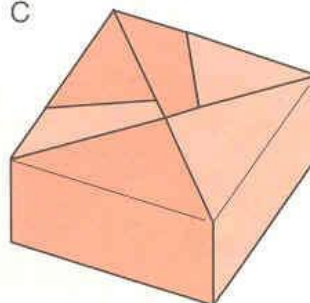

◆ Lightning ◆



◆ Bowknot ◆

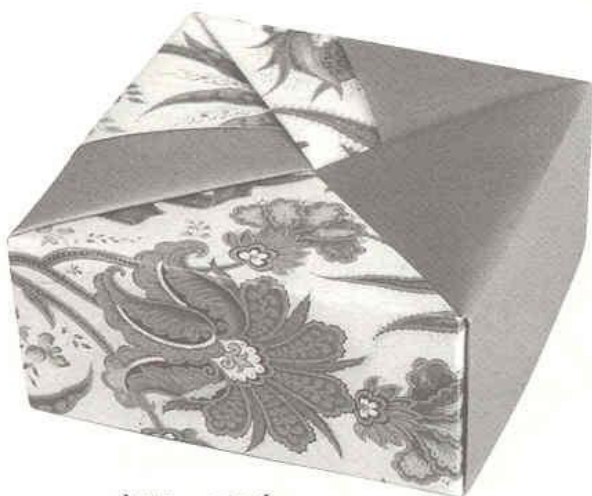

◆ Mixed C ◆

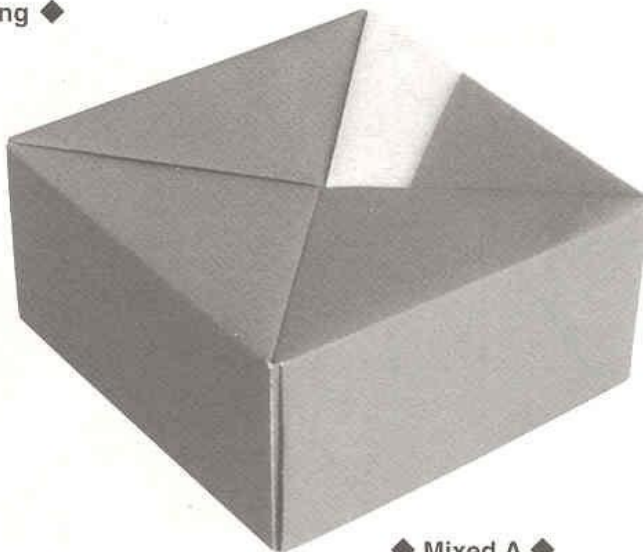

◆ Mixed A ◆

Square Box from a Rectangle *Body*

This box is used as the body. If you change the length of (a) of ④, you can make nesting boxes.

Use the same size paper of the lid (p.36).

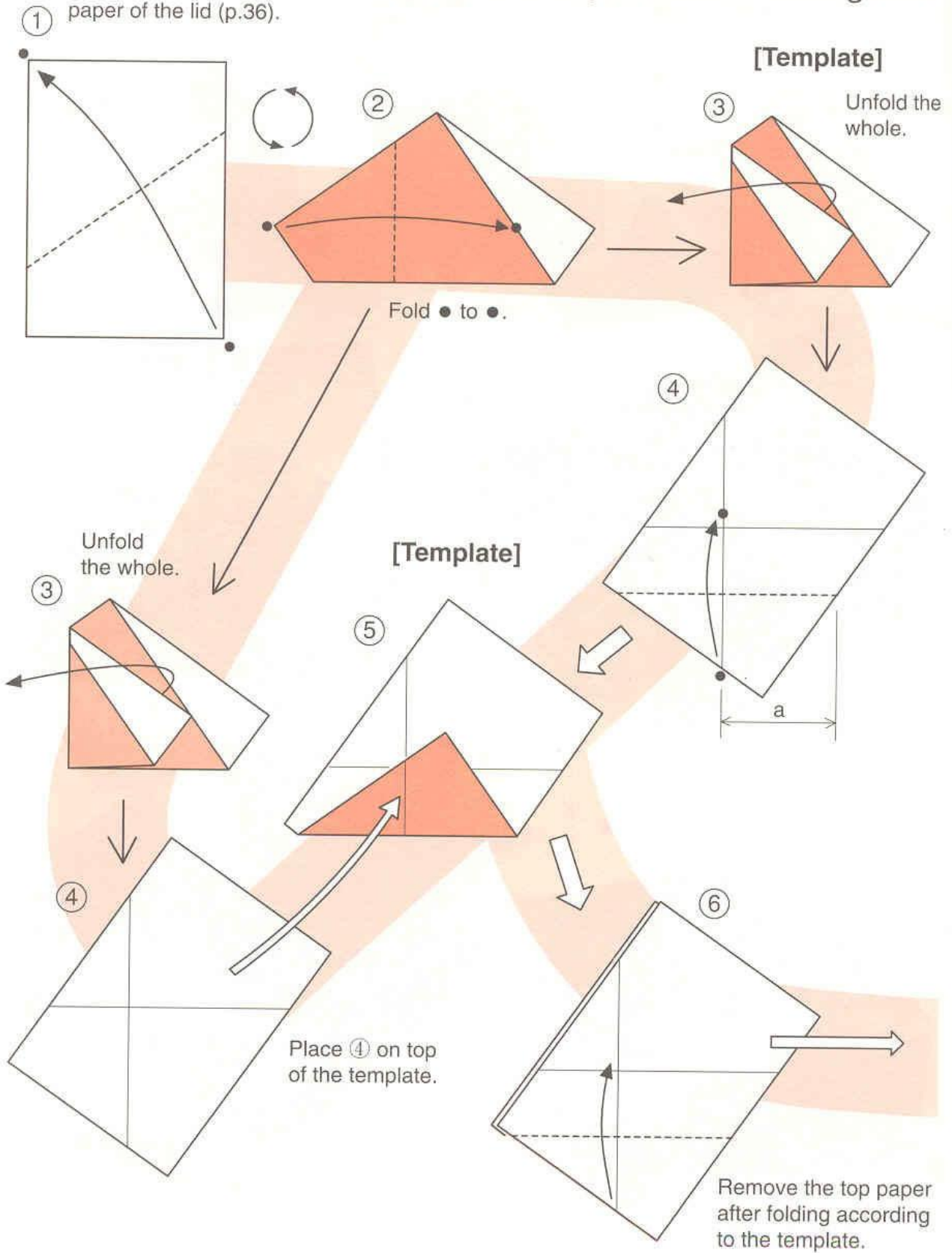

See page 37 for assembly.

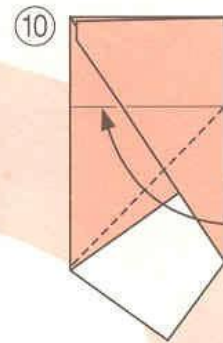
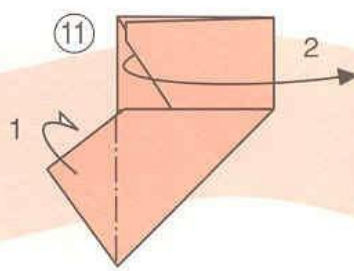
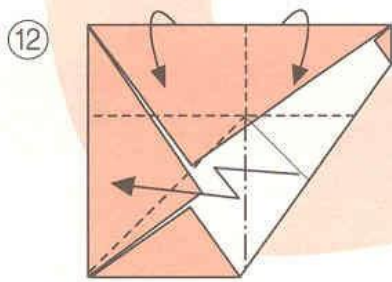
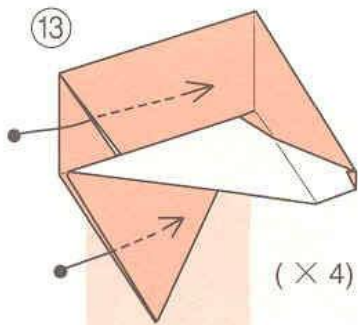
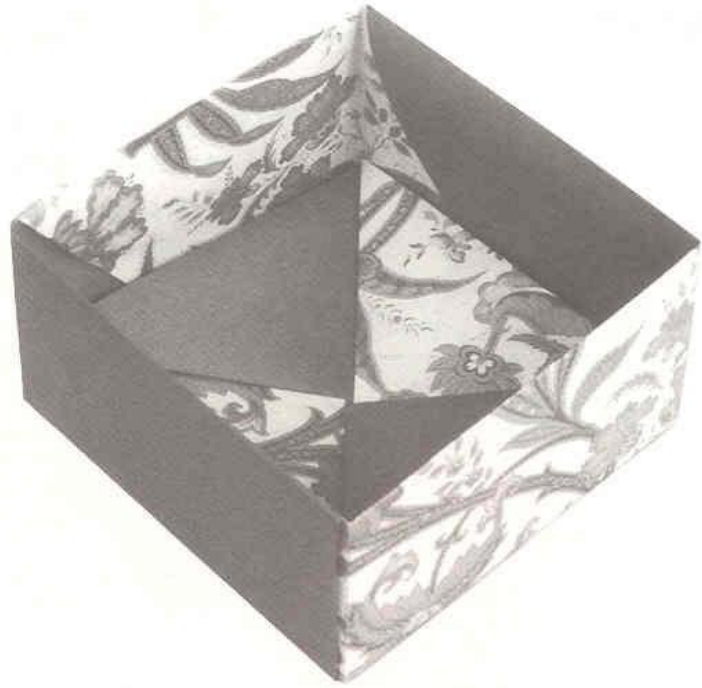

Fold in numerical order.

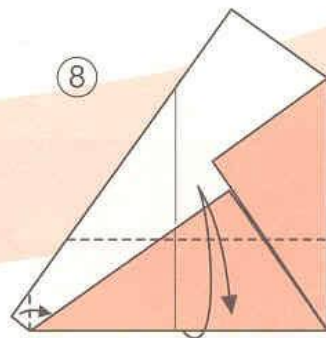
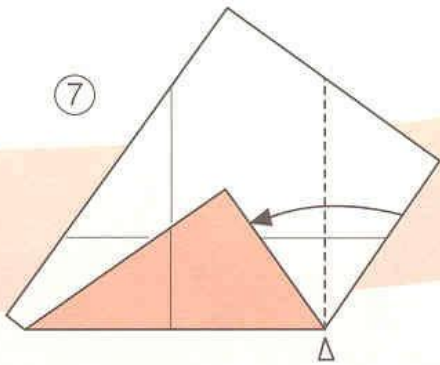
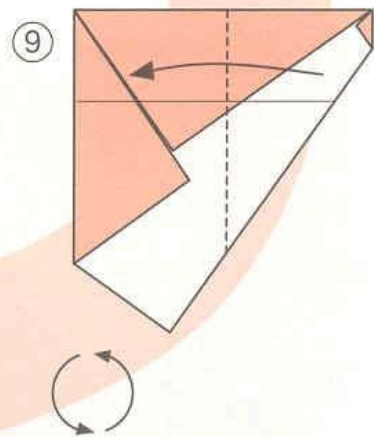

Lamp-shaped Bowl *Standard*

This bowl looks like a Japanese lamp.
 It is stronger than you expect.
 If you change the width of step ②, you can get
 nesting bowls of various sizes, larger and smaller.

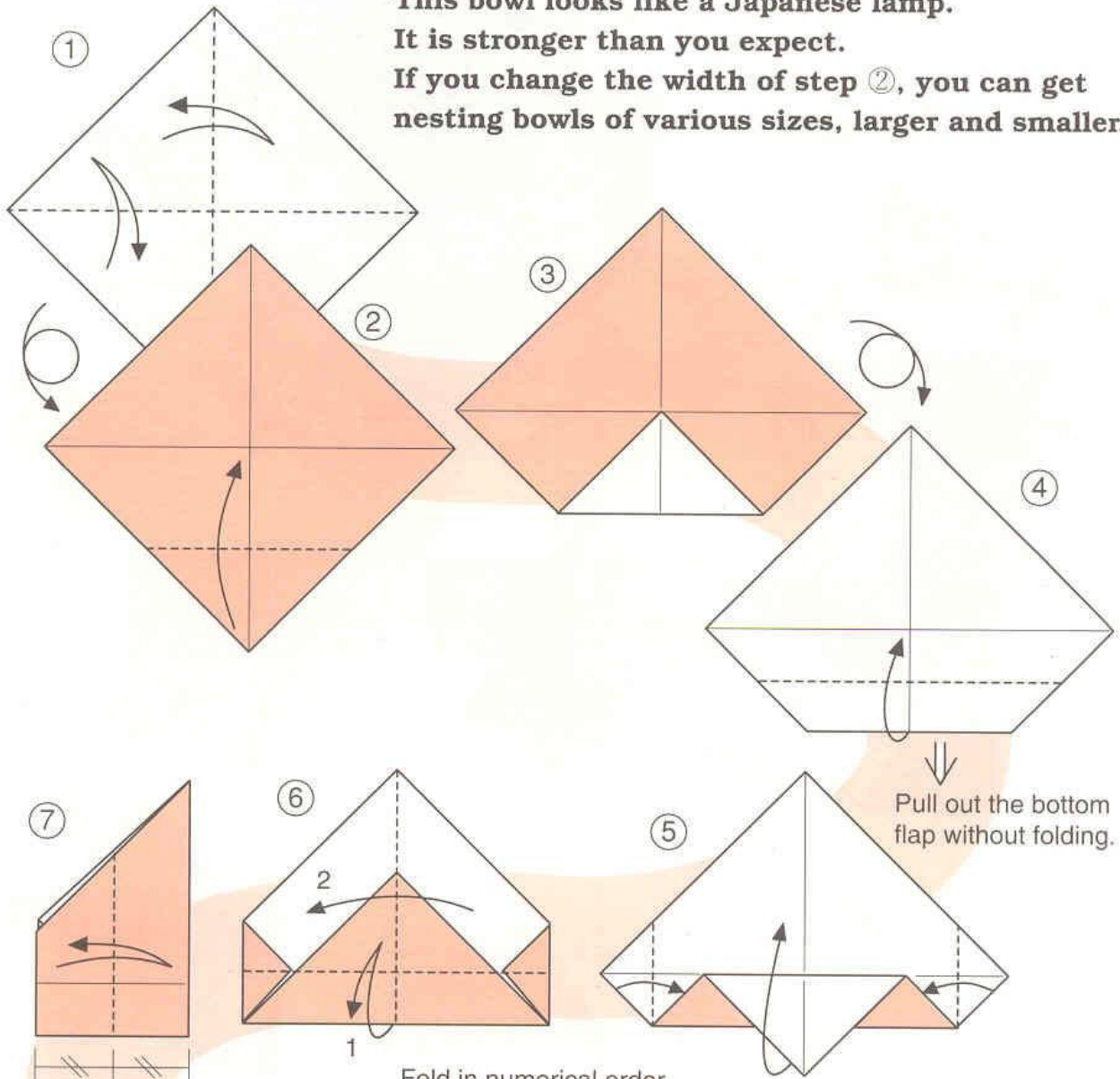

Pull out the bottom flap without folding.

Fold in numerical order.

Fold only the top layer.

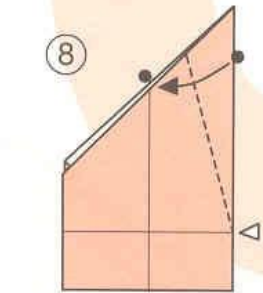

Using Δ as a pivot, fold ● to ●.

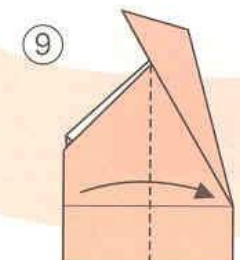

Fold only the top layer.

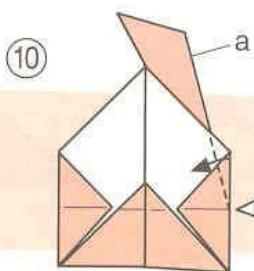

Fold along edge (a).

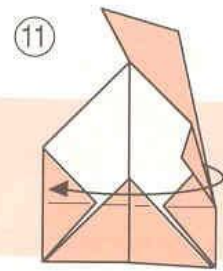

Unfold.

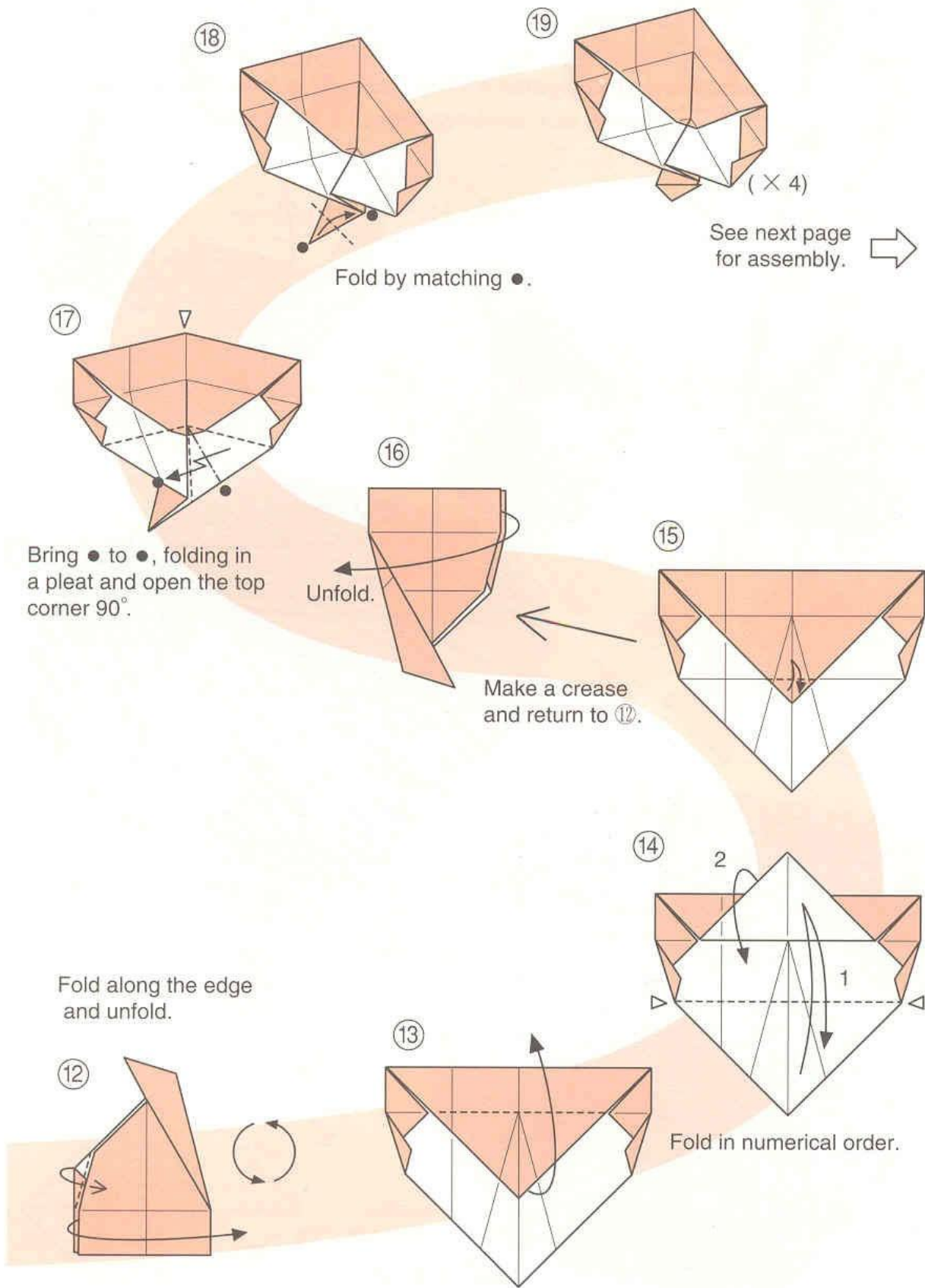

[Assembly]

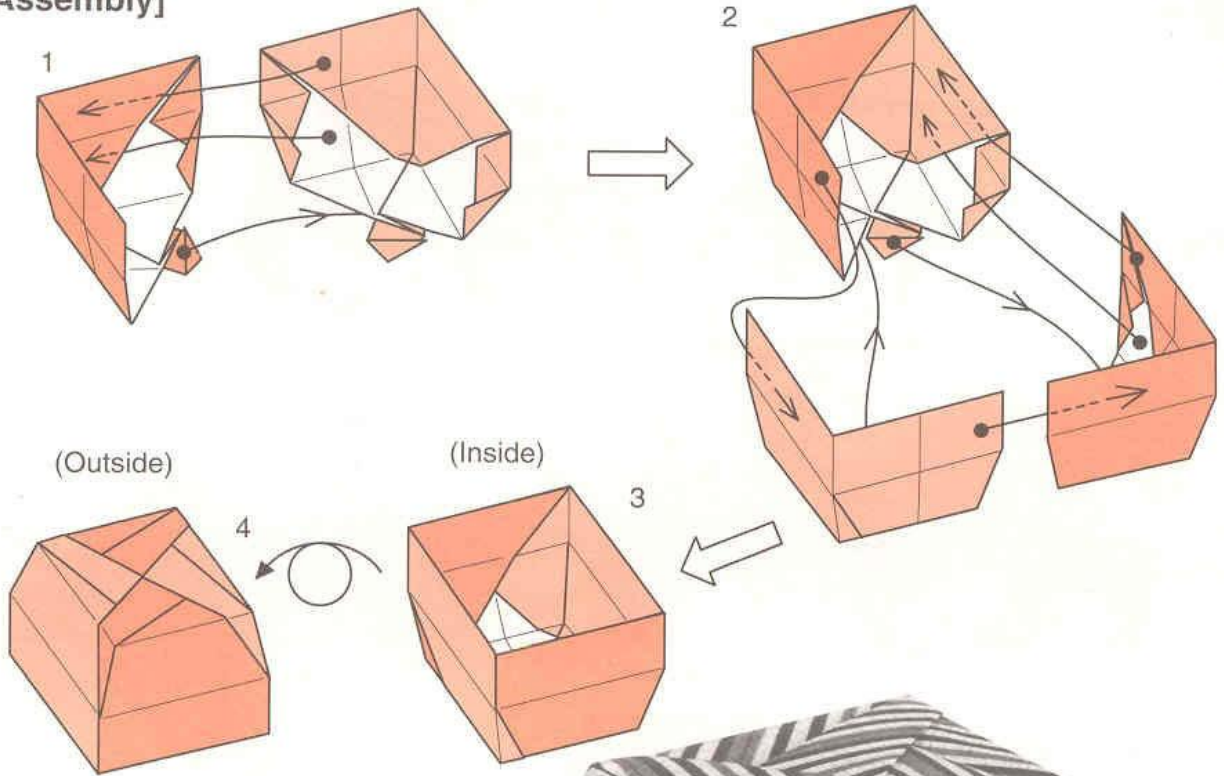

Lamp-shaped Bowl

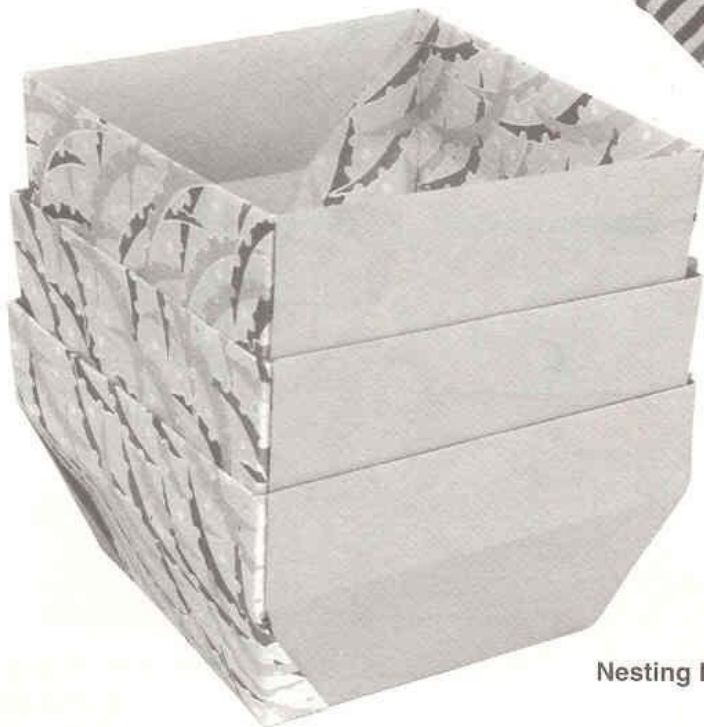

Nesting Bowls

Measurements of Nesting Bowls

The size of bowls depends on how to fold, near the center or further from the center. When you finished folding one, make it a template and fold the other three units according to the template's measurements.

For your reference, a list of measurements is given.

Size 2 · Deeper and smaller than the standard

► Size 3 · Standard ◀

Size 4 · Shallower and larger than the standard

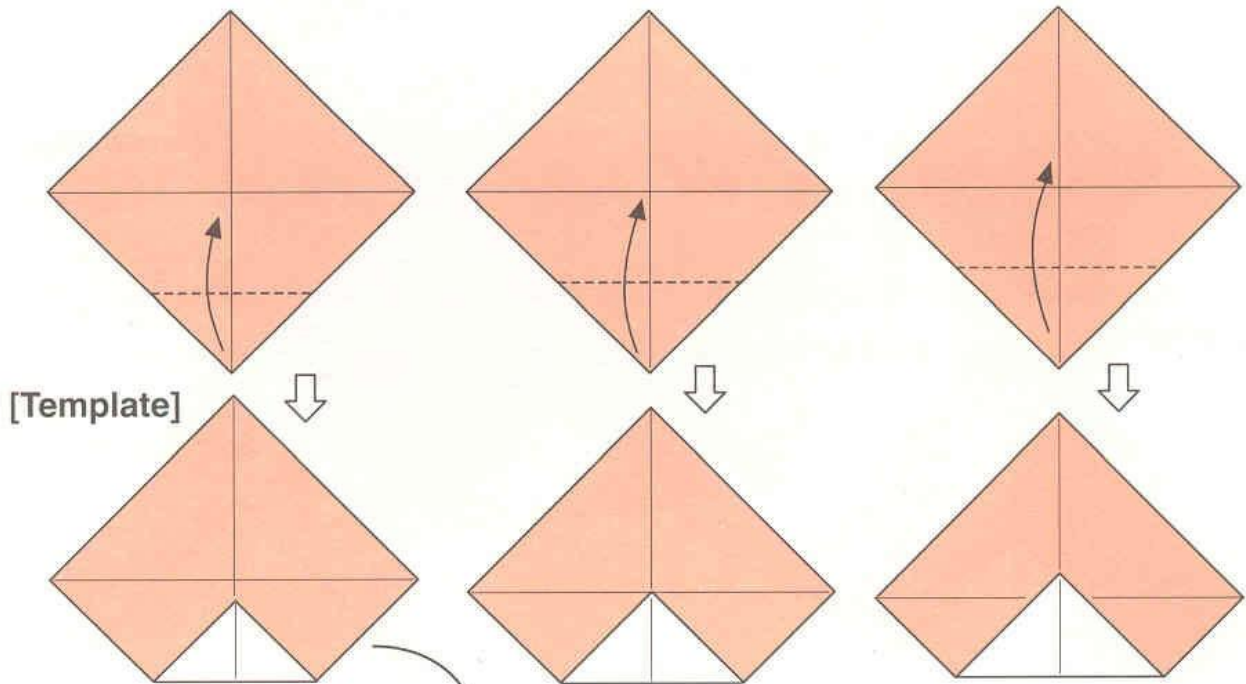

Place new paper on top of the template and fold according to the measurements.

Place under.

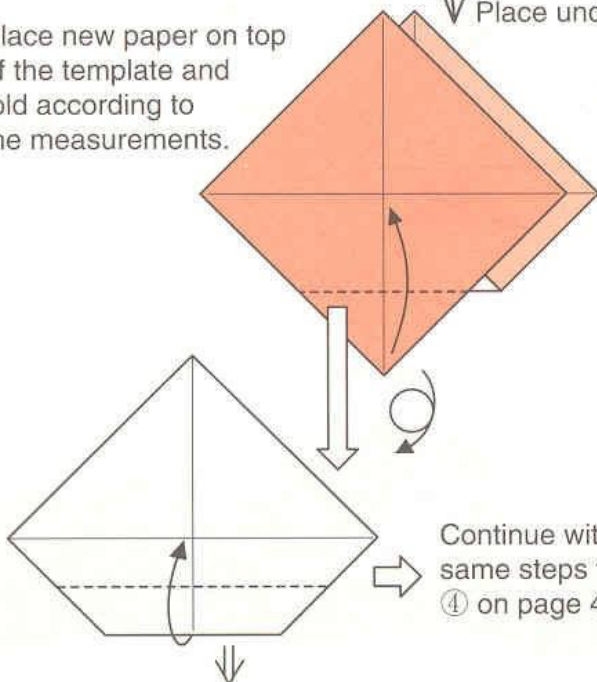

Continue with the same steps from ④ on page 42.

List of Measurements

Folding lines of step ② on page 42.

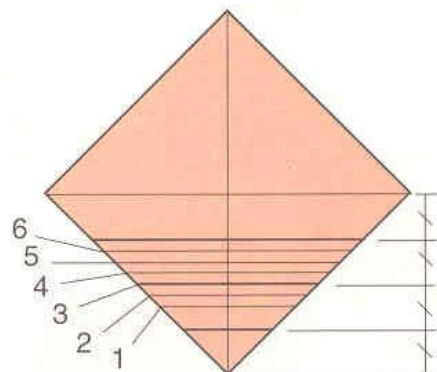

Line 3 is the folding line of the standard size. The higher the number is, the shallower and larger the bowls become.

Lamp-shaped Bowl *Lid with a knob*



Size 4 · Shallower and larger than the standard

This is the lid with a knob for the body of the standard size bowl (size 3).
Of course, other lids of different sizes are obtainable by the same methods.

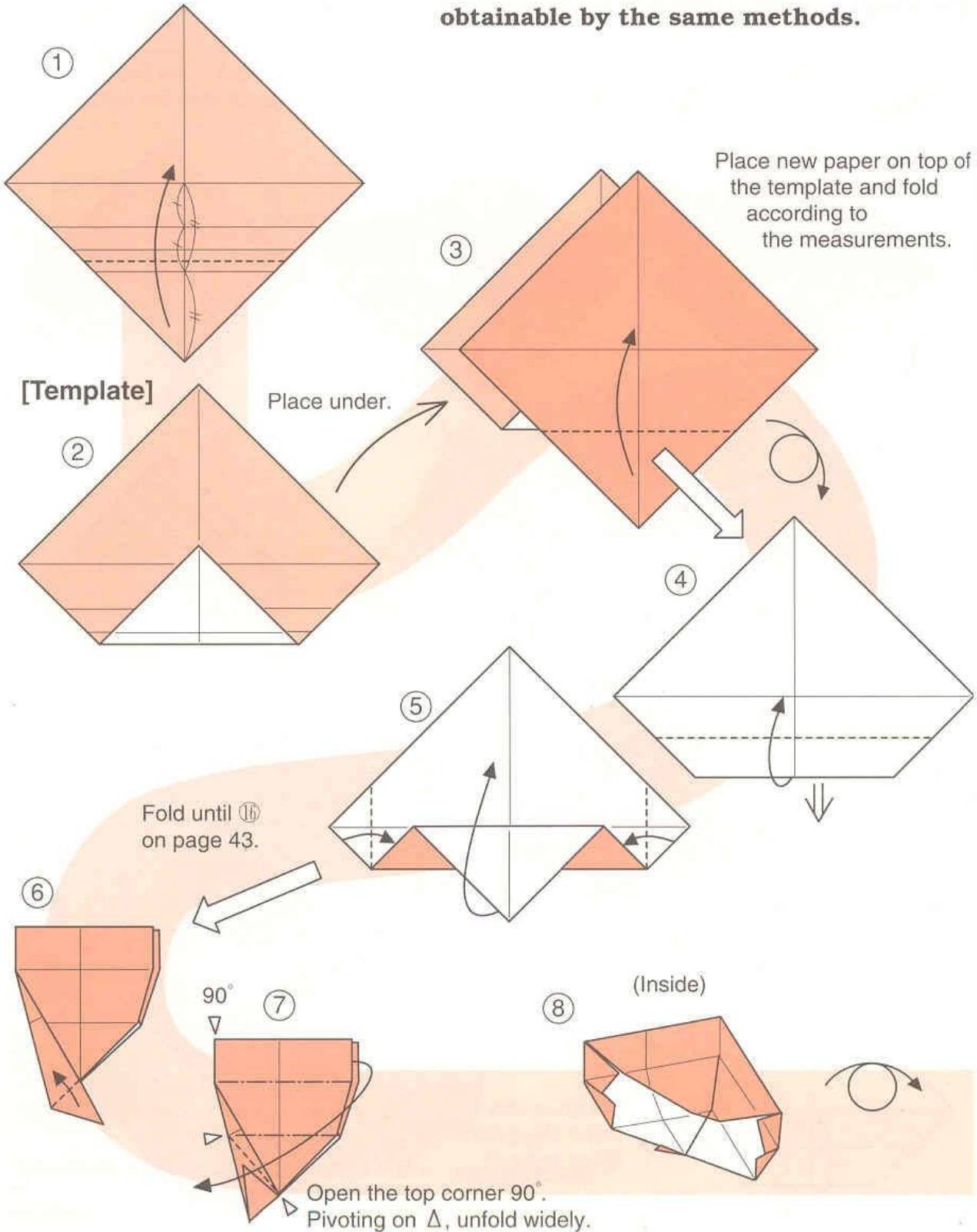

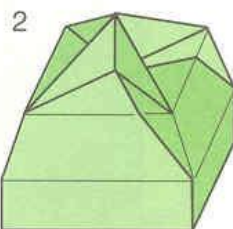

[Assembly] 1



(Outside)

9

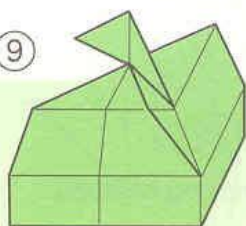

(X 4)

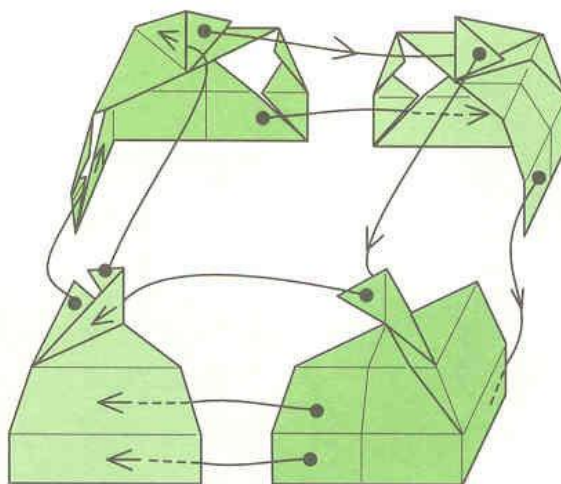

Square Box Plain

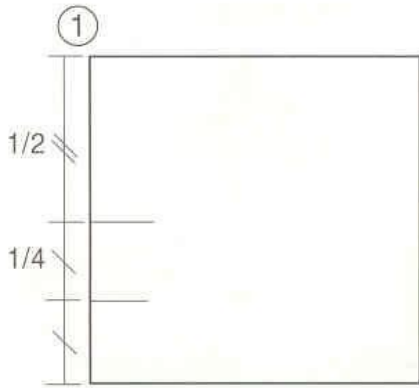

Make creases on the edge as illustrated.

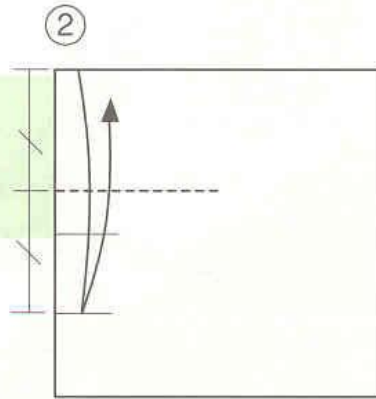

Make a crease a little longer than half.

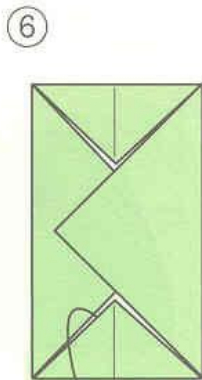
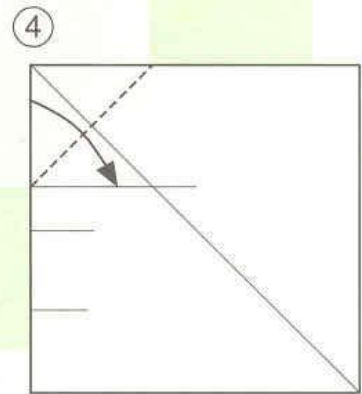
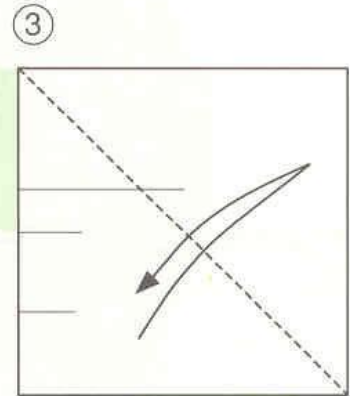

Unfold.

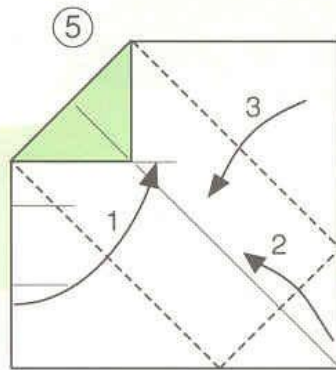

Fold in numerical order.

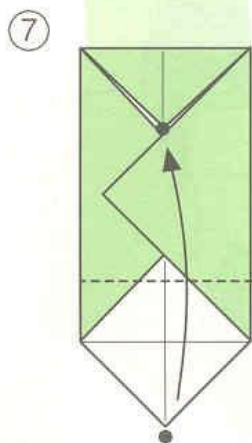

Fold ● to ●.

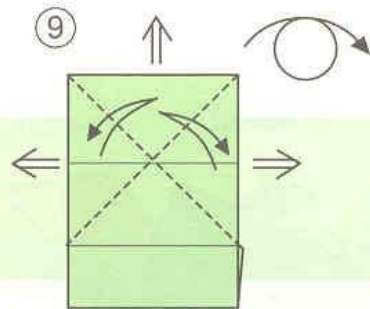
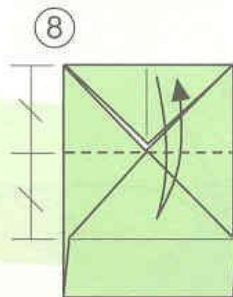

Unfold after making creases.

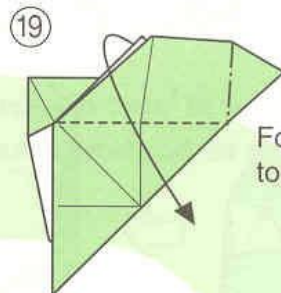
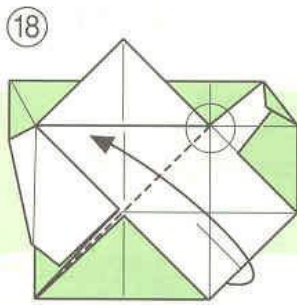
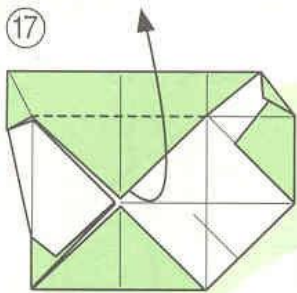

Fold down two flaps together.

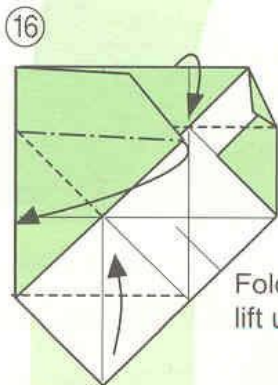

Fold as far as ○.

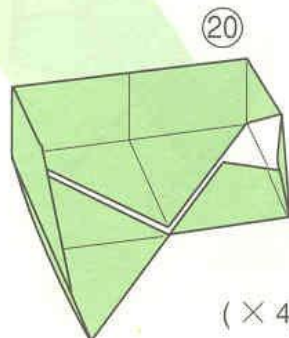

(x4)

See next page for assembly.

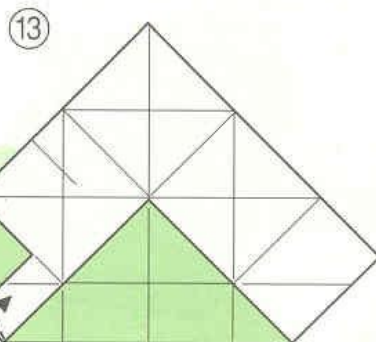
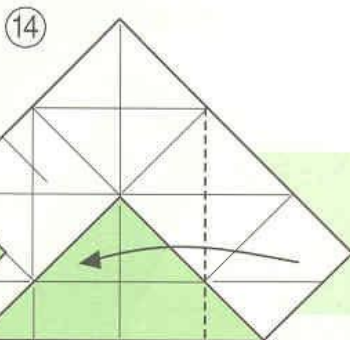
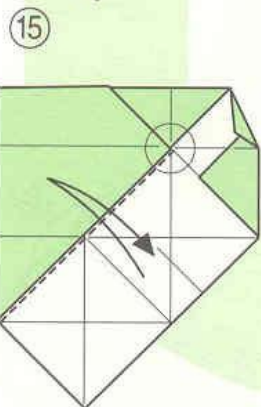

Fold as far as ○.

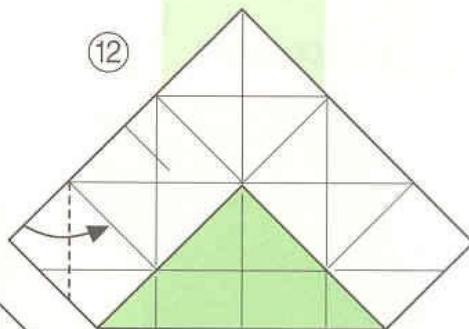
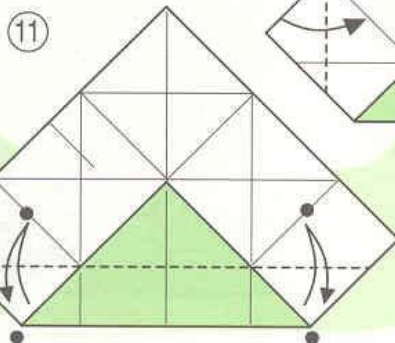
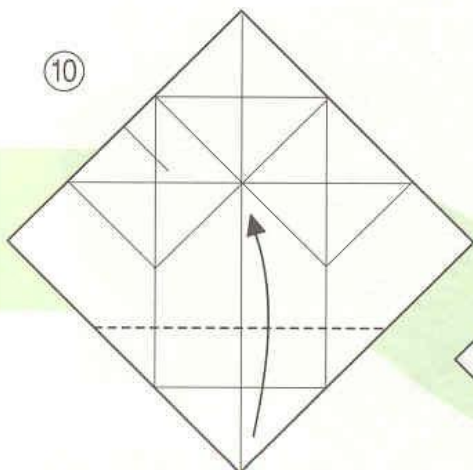

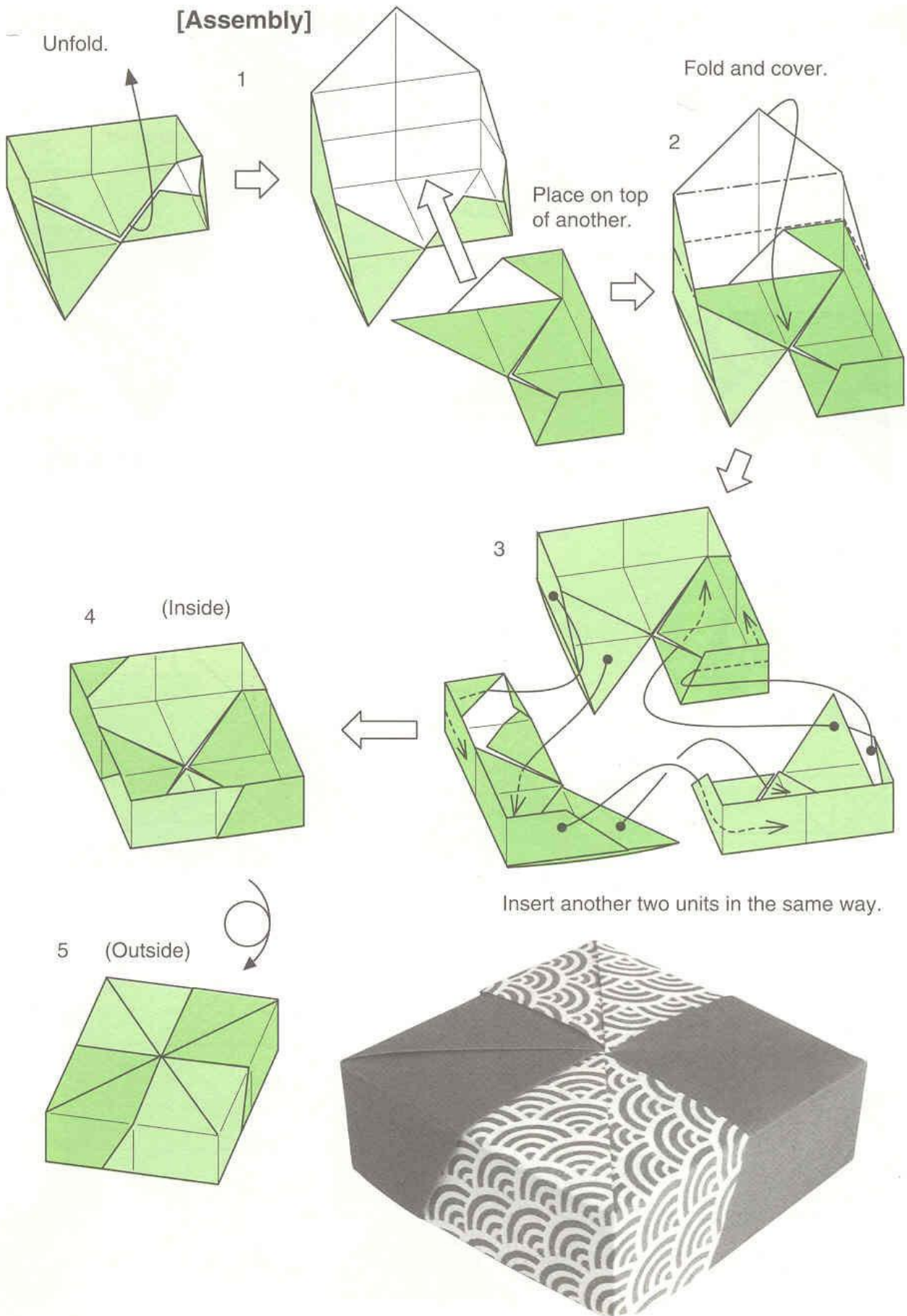

Square Box Crane 1

This box has cranes on top. It is possible to fold various other figures instead of cranes.

Begin with step ⑪ on page 49.

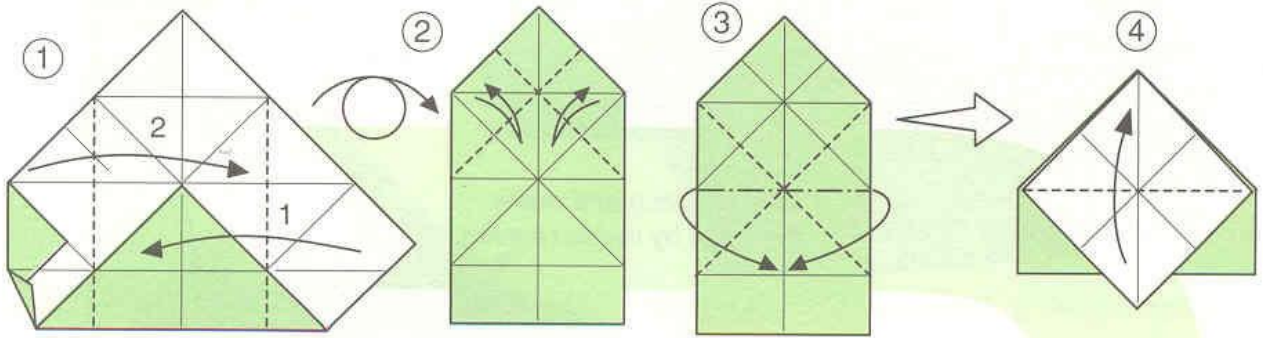

Fold in numerical order.

Open and flatten.

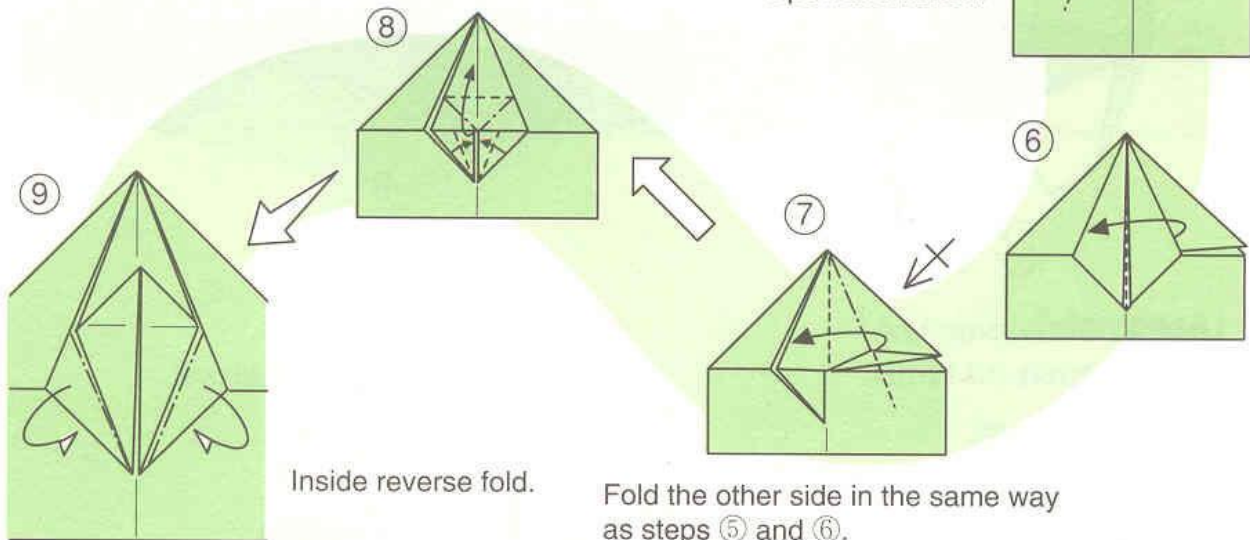

Inside reverse fold.

Fold the other side in the same way as steps ⑤ and ⑥.

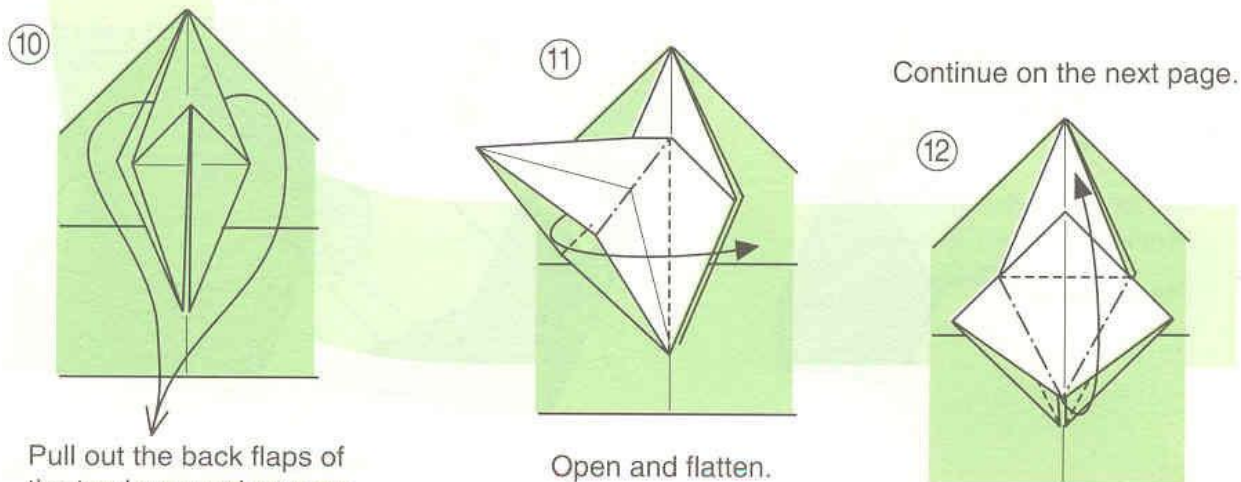

Pull out the back flaps of the top layer and reverse.

Open and flatten.

Continue on the next page.

13

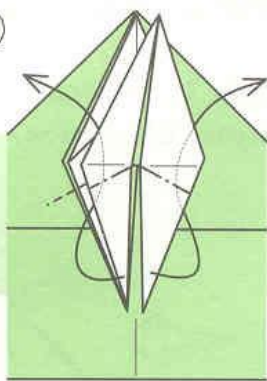

Inside reverse fold.

14

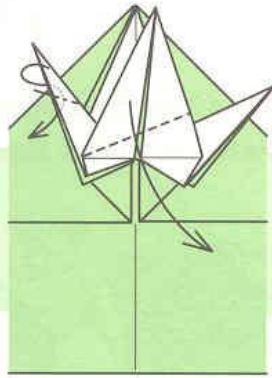

Fold the wing and make the head by inside reverse fold.

15

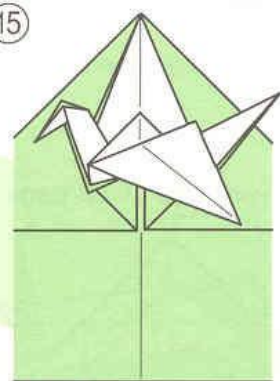

18

(Inside)

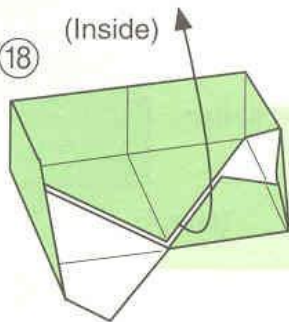

17

(Outside)

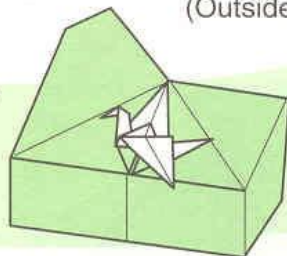

(× 4)

16

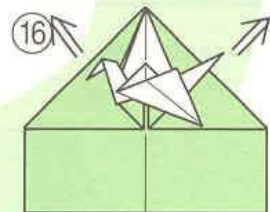

[Assembly]

1

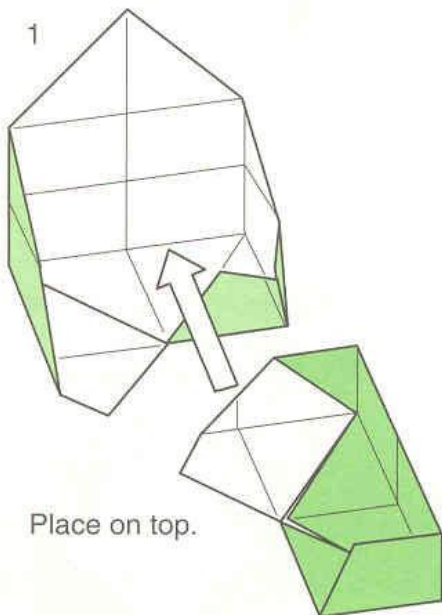

Place on top.

Fold over.

2

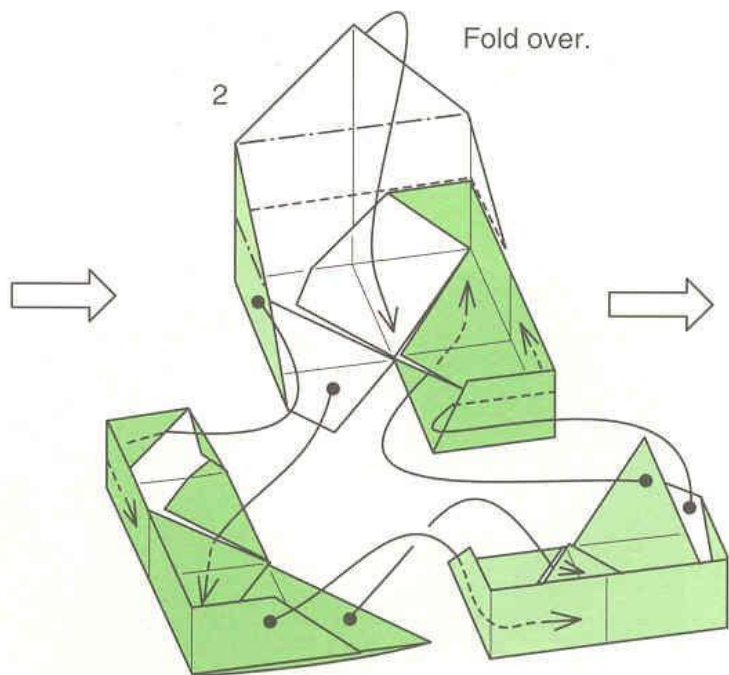

Insert the other two units in the same way.

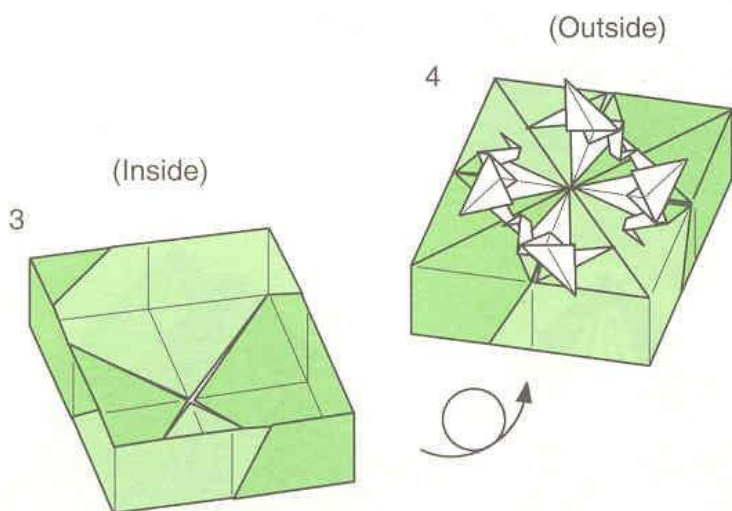
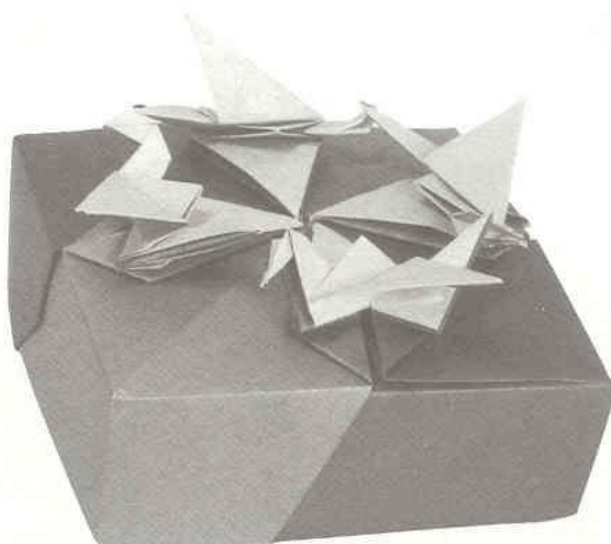
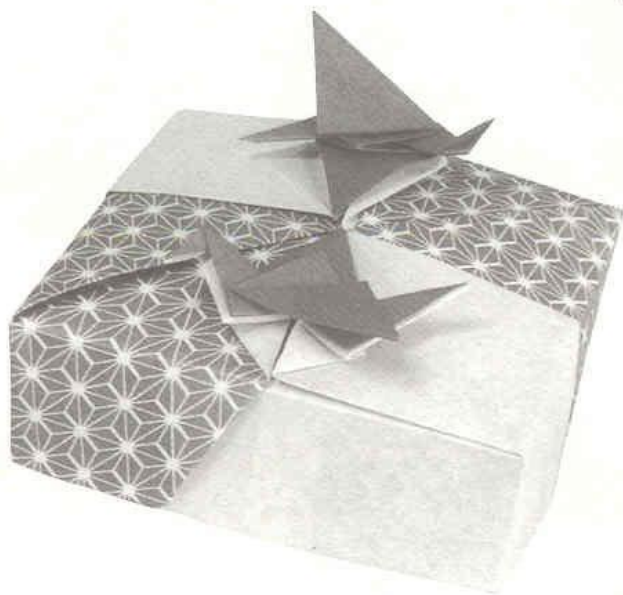

Assembly with plain units on page 48

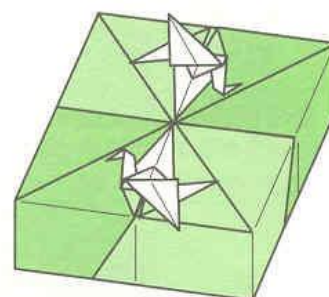

(Crane \times 2) + (Plain \times 2)

Experiment with different ways of joining with other units as above.

Square Boxes *Iris & Bouvardia*

◆ IRIS ◆

Begin with step ⑩ on page 51.

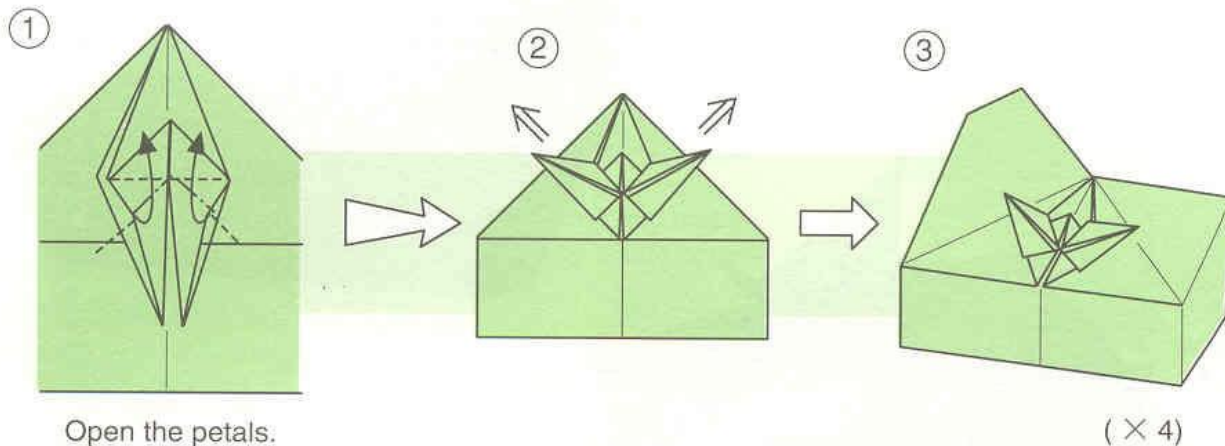

◆ BOUVARDIA ◆

Begin with step ⑫ on page 51.

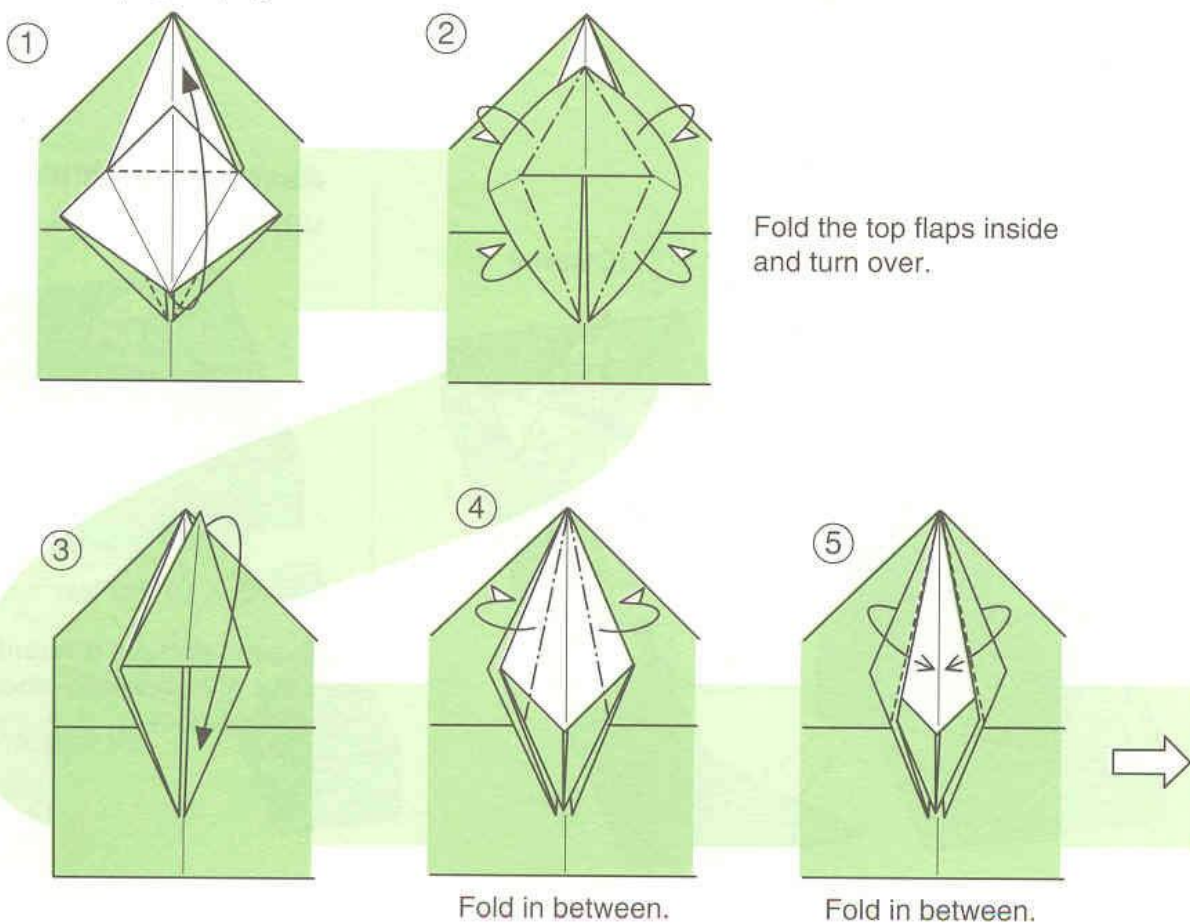

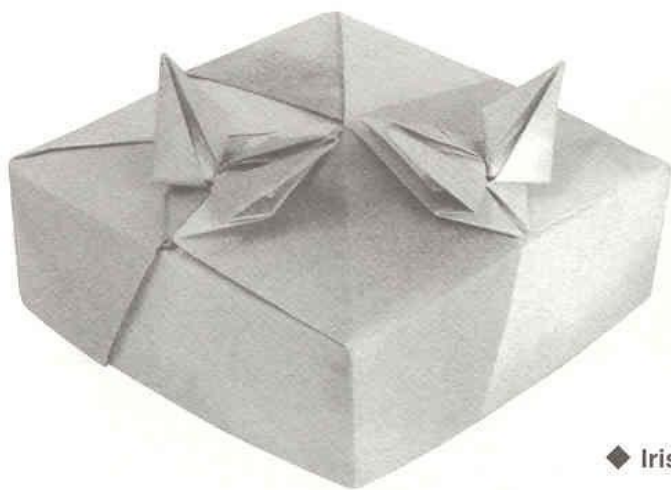

◆ Iris ◆

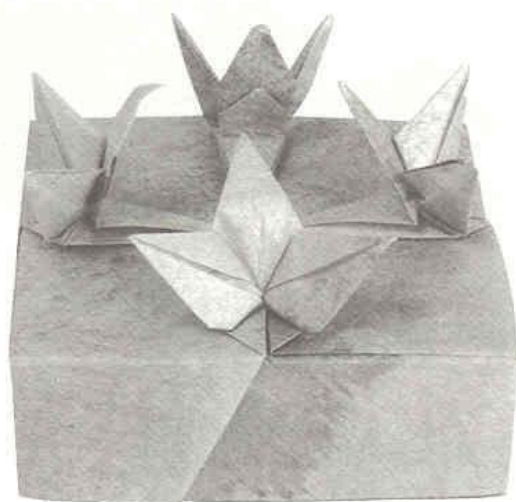

◆ Bouvardia ◆

See page 52 for assembly.
Joining methods are the same
for the iris and bouvardia.

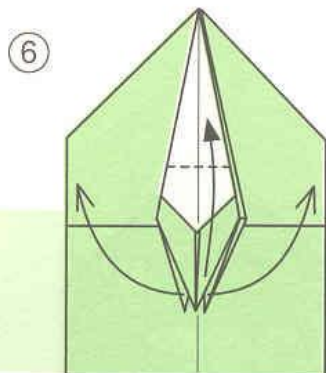

Open the petals.

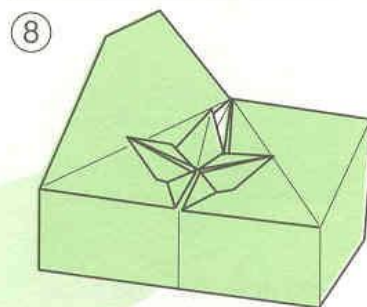
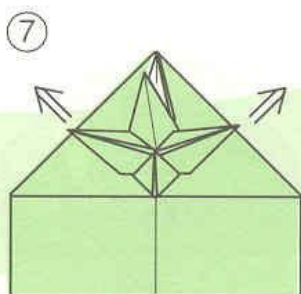

(× 4)

Square Box *Heart*

A box with a heart on top.
It is interesting to join with plain boxes.

Begin with step ⑭ on page 49.

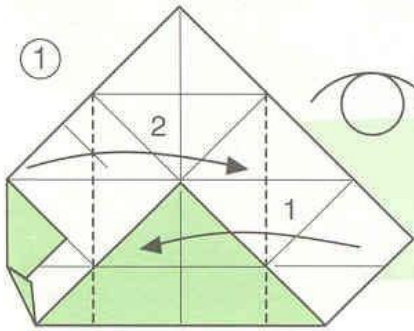

Fold in numerical order.

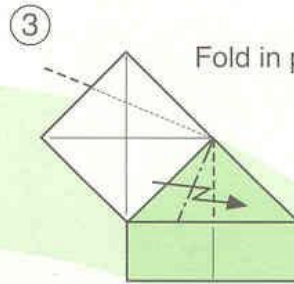
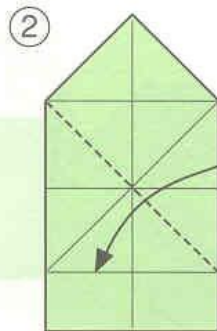

Fold in pleat.

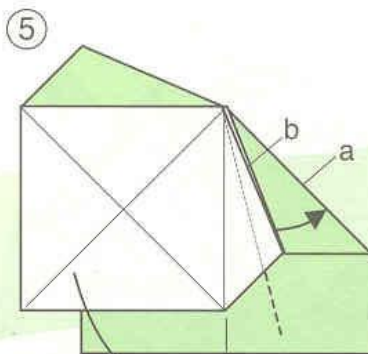

Align (a) and (b) edges together and fold.

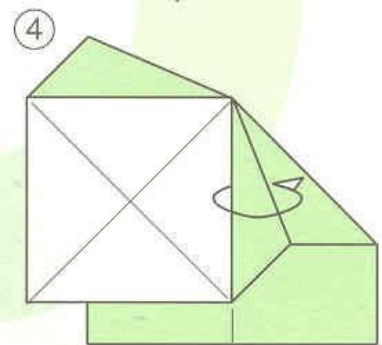

Turn over and reverse.

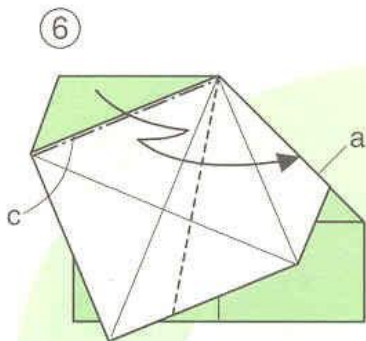

Align (a) and (c) edges together and fold.

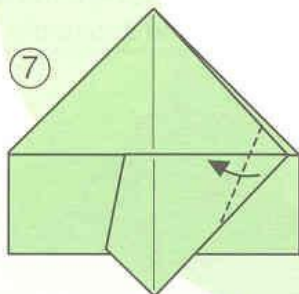

Fold and align the edge with the behind flap.

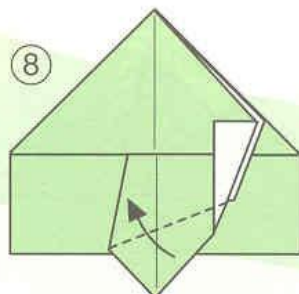

Fold and align the edge with the behind flap.

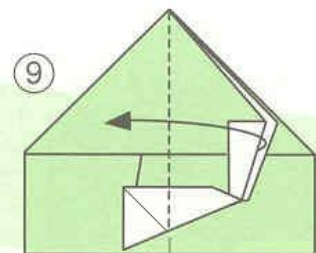

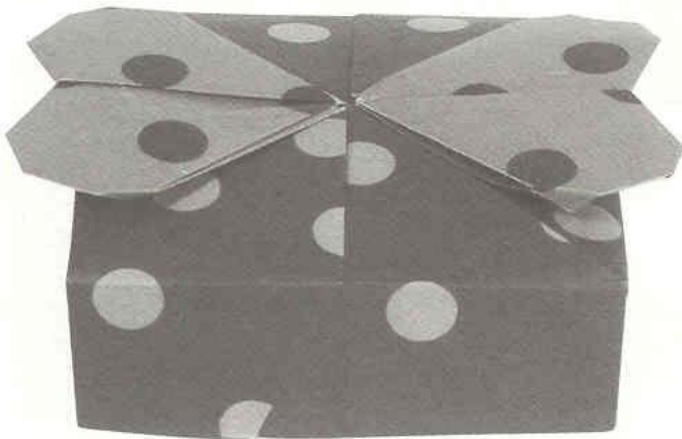

See page 52
for assembly.

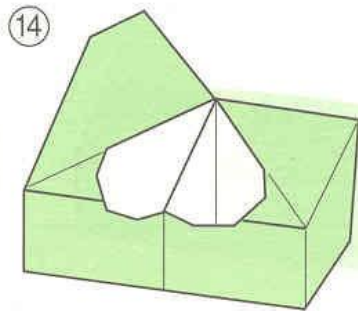

Fold each corner
of the heart and
pull out the under layers.

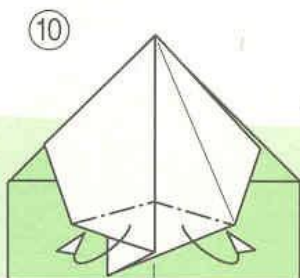
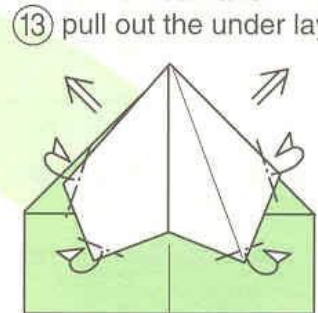

The inside behind
the heart.

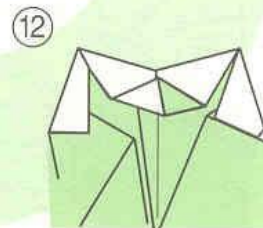
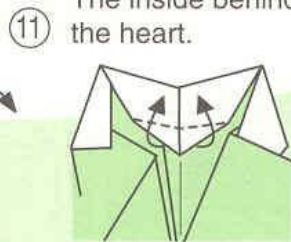

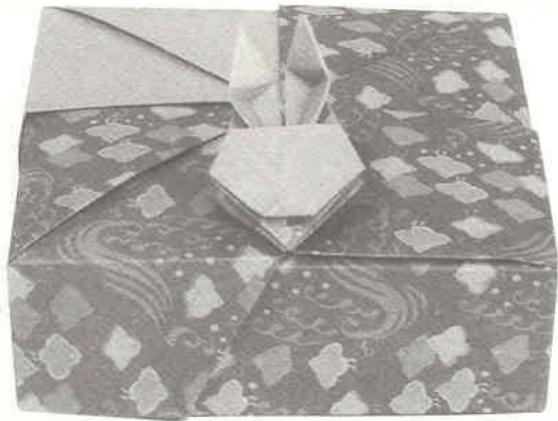

◆ Rabbit ◆

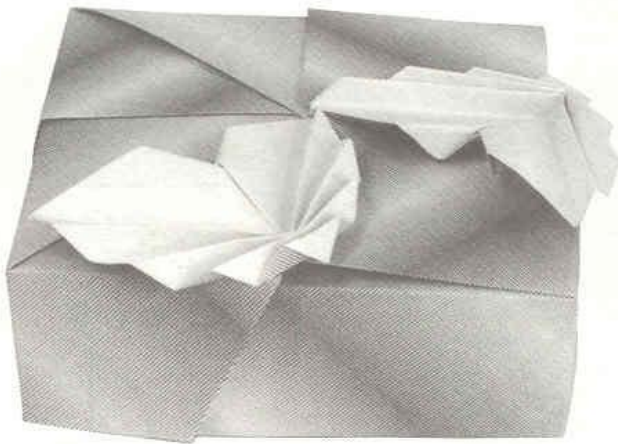

◆ Butterfly ◆

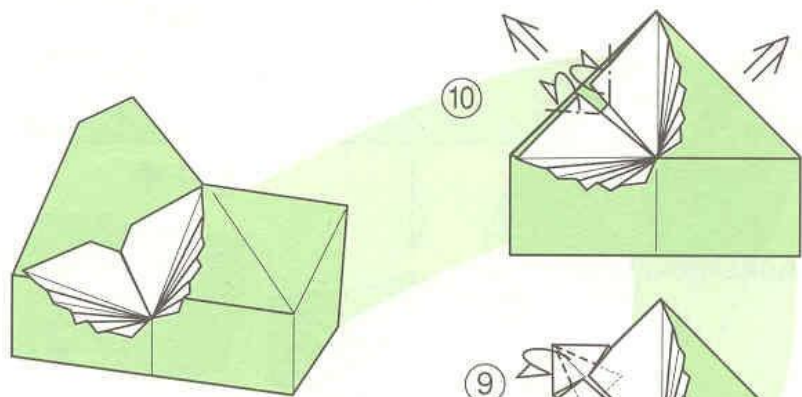

⑩

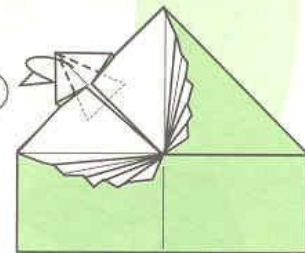

⑨

See page 52
for assembly.

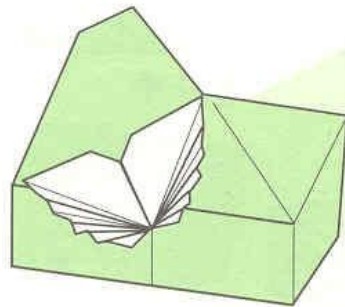

⑦

Fold in pleats.

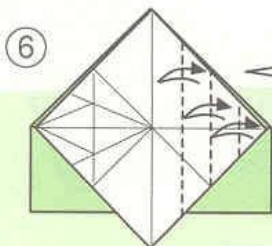

⑥

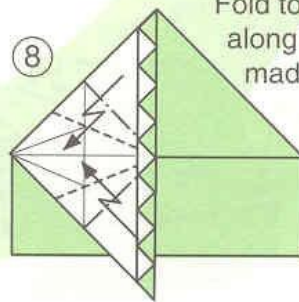
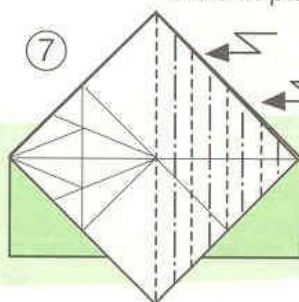

⑧

Fold to the reverse
along the creases
made in step ④.

Square Box with a Tab

Begin with step ④ on page 49.

A box with a tab. You may assemble other units, using B and C.

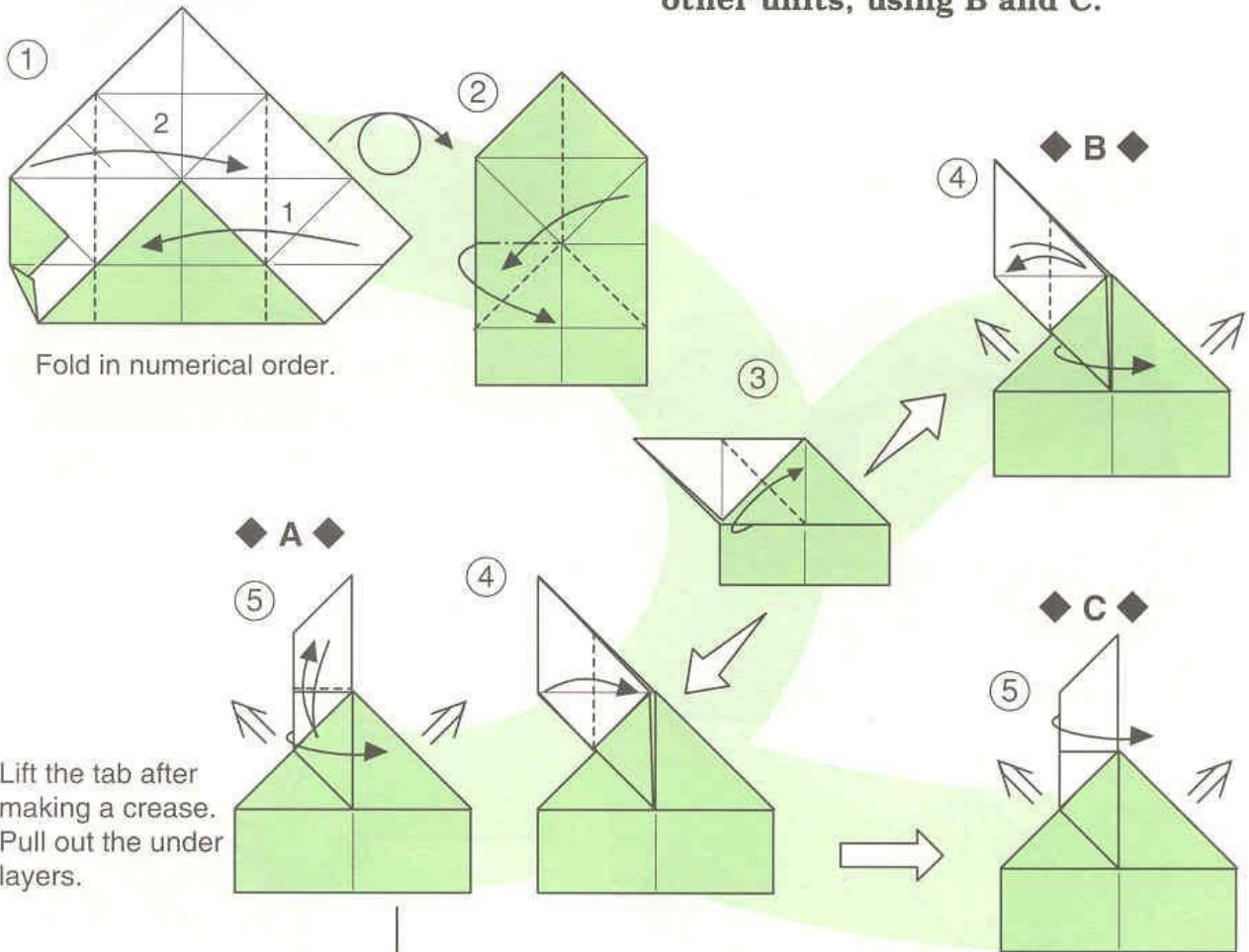

[Assembly]

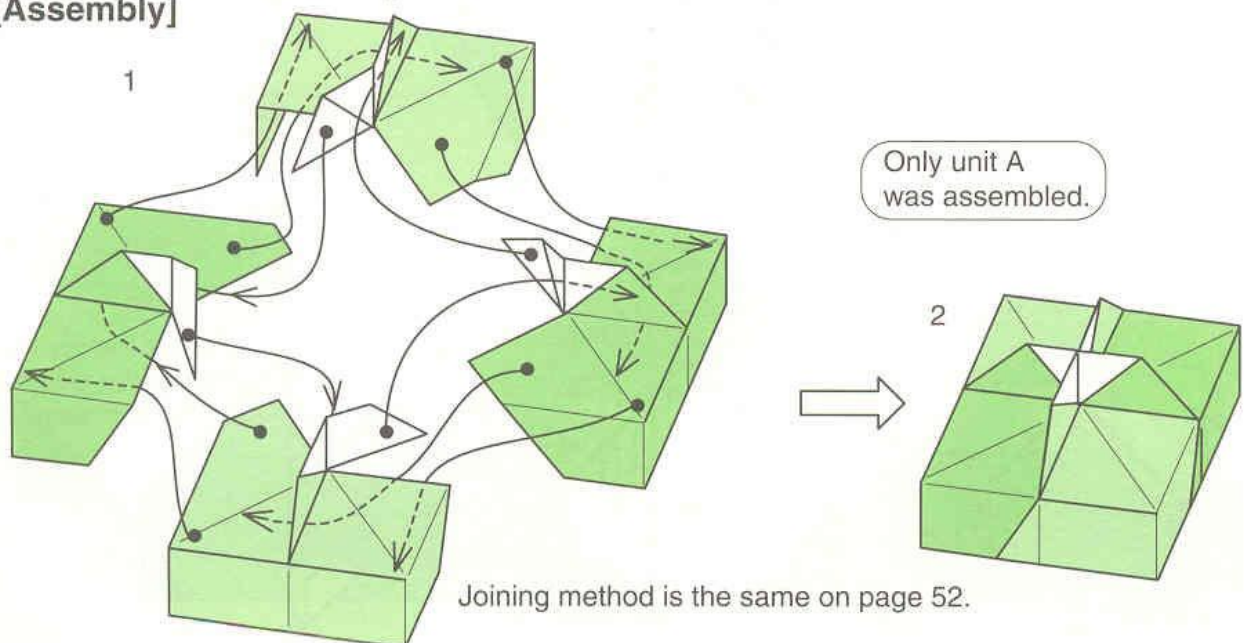



[Another assembly]

As shown here, you may join one kind of unit placed outside. Joining method is the same on page 52.

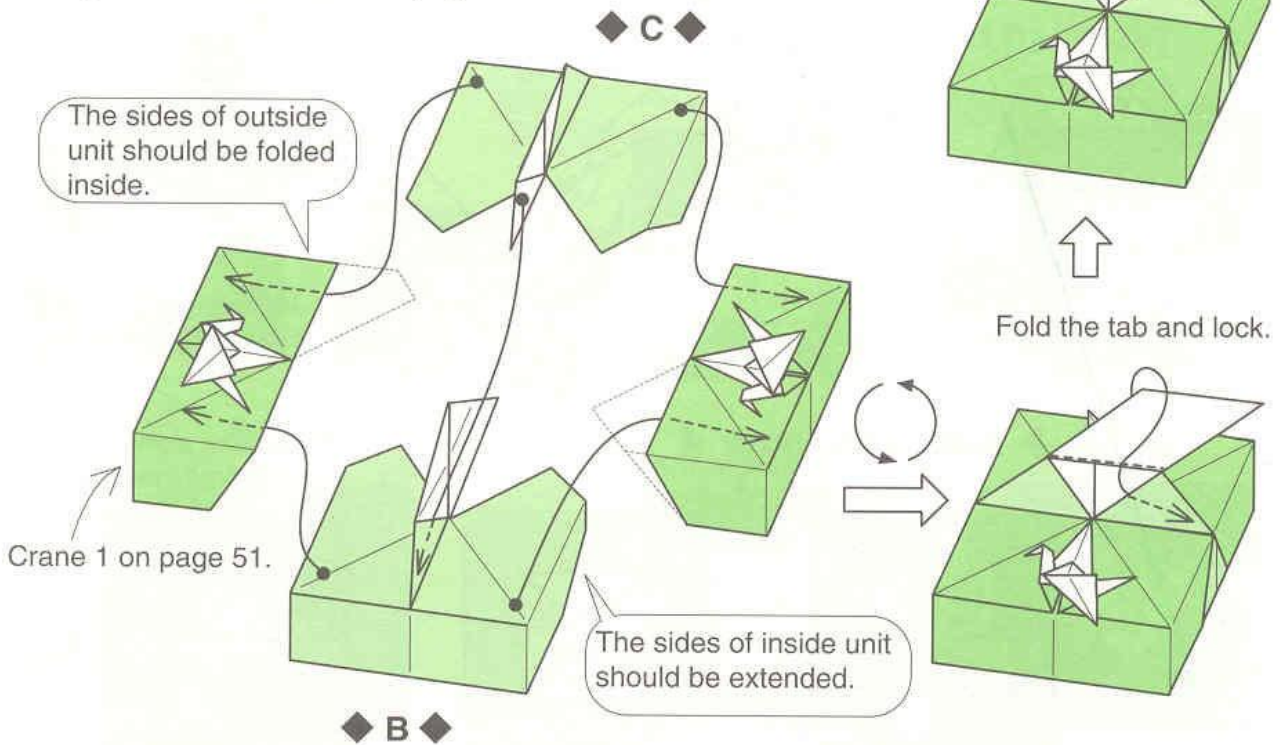

Square Box *Vortex*

Begin with step ③ on page 60.

**Fold each end of units step-by-step in circle.
You may stop the process halfway and assemble.**

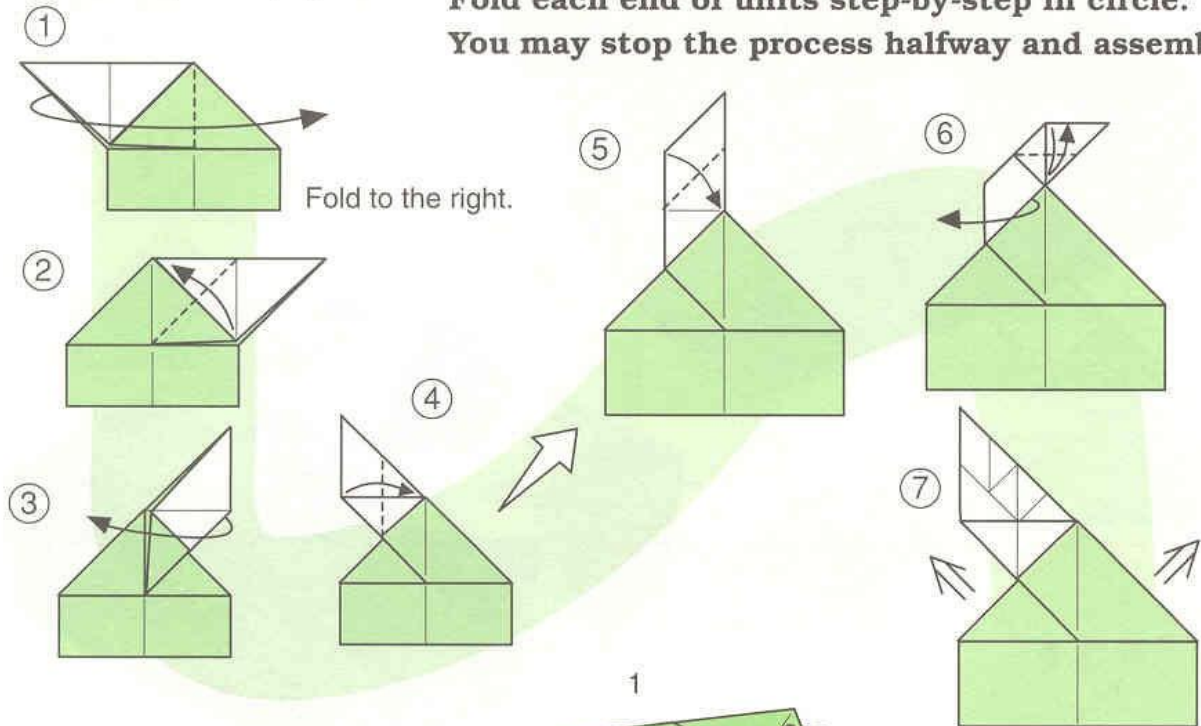

[Assembly]

◆ A ◆

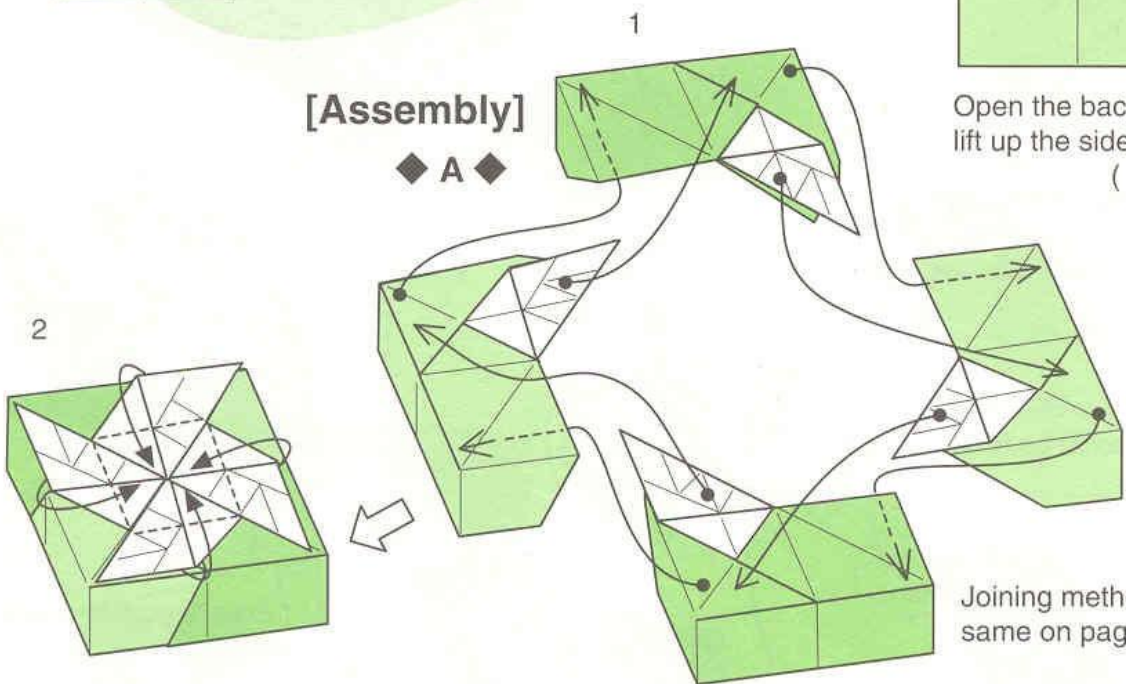

Open the back and lift up the sides.
(× 4)

Joining method is the same on page 52.

▶ **Seen from above** ◀

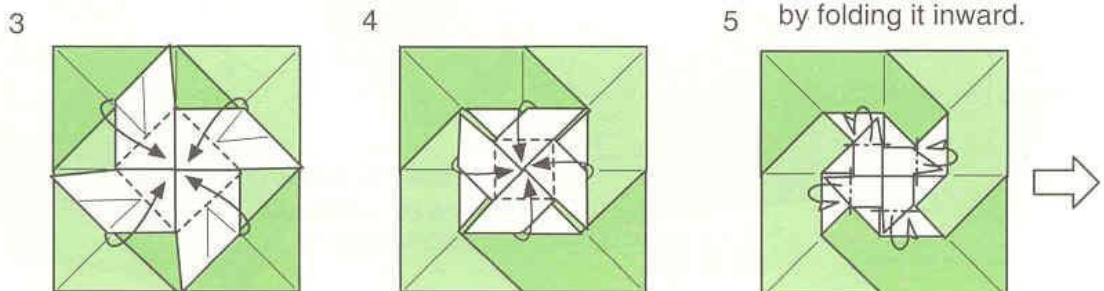

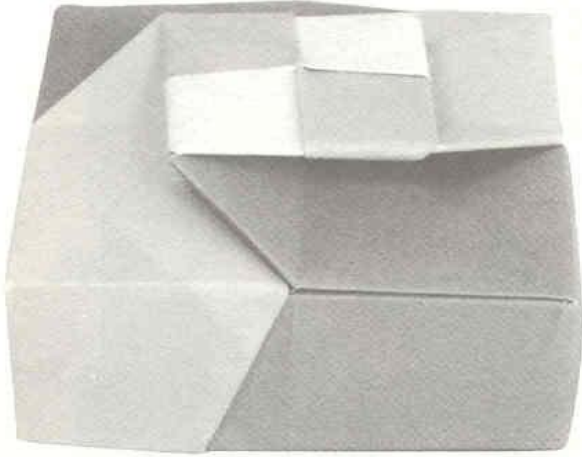

◆ B ◆

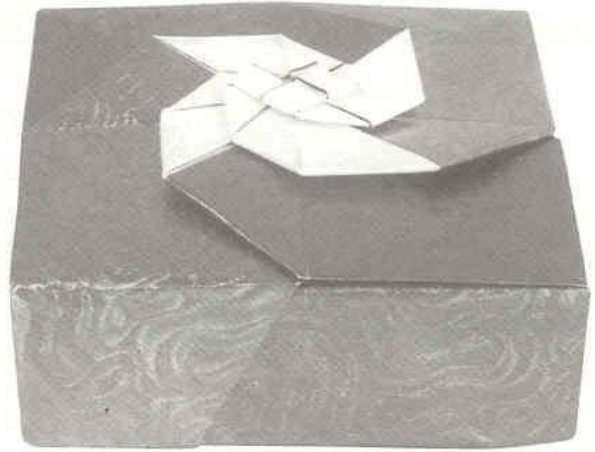

◆ A' ◆

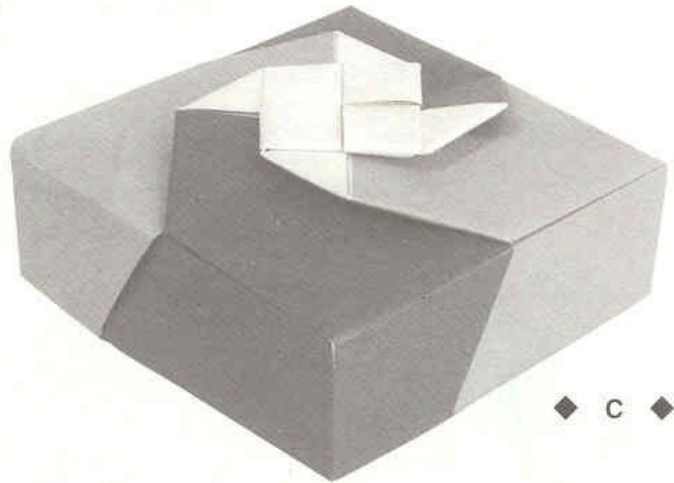

◆ C ◆

◆ A' ◆ Make an additional vortex on A.

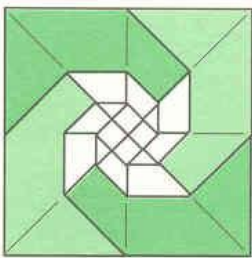

◆ A ◆

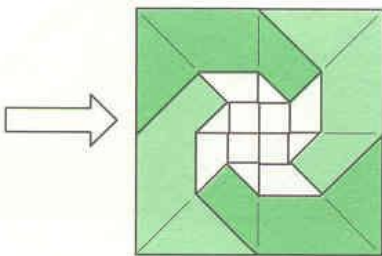

[Assembly formed halfway]

From assembly 3

◆ B ◆

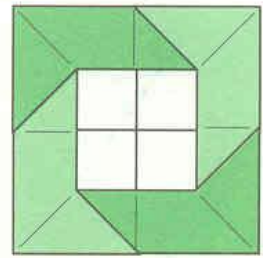
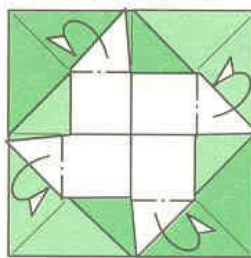

From assembly 4

◆ C ◆

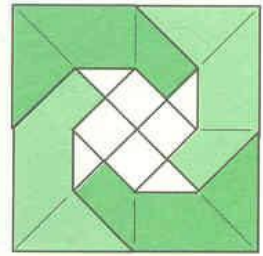
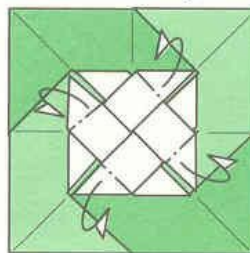

Square Box *Hydrangea*

If you change the color of paper,
the hydrangea will turn into a pink.

Begin with step ⑩ on page 49.

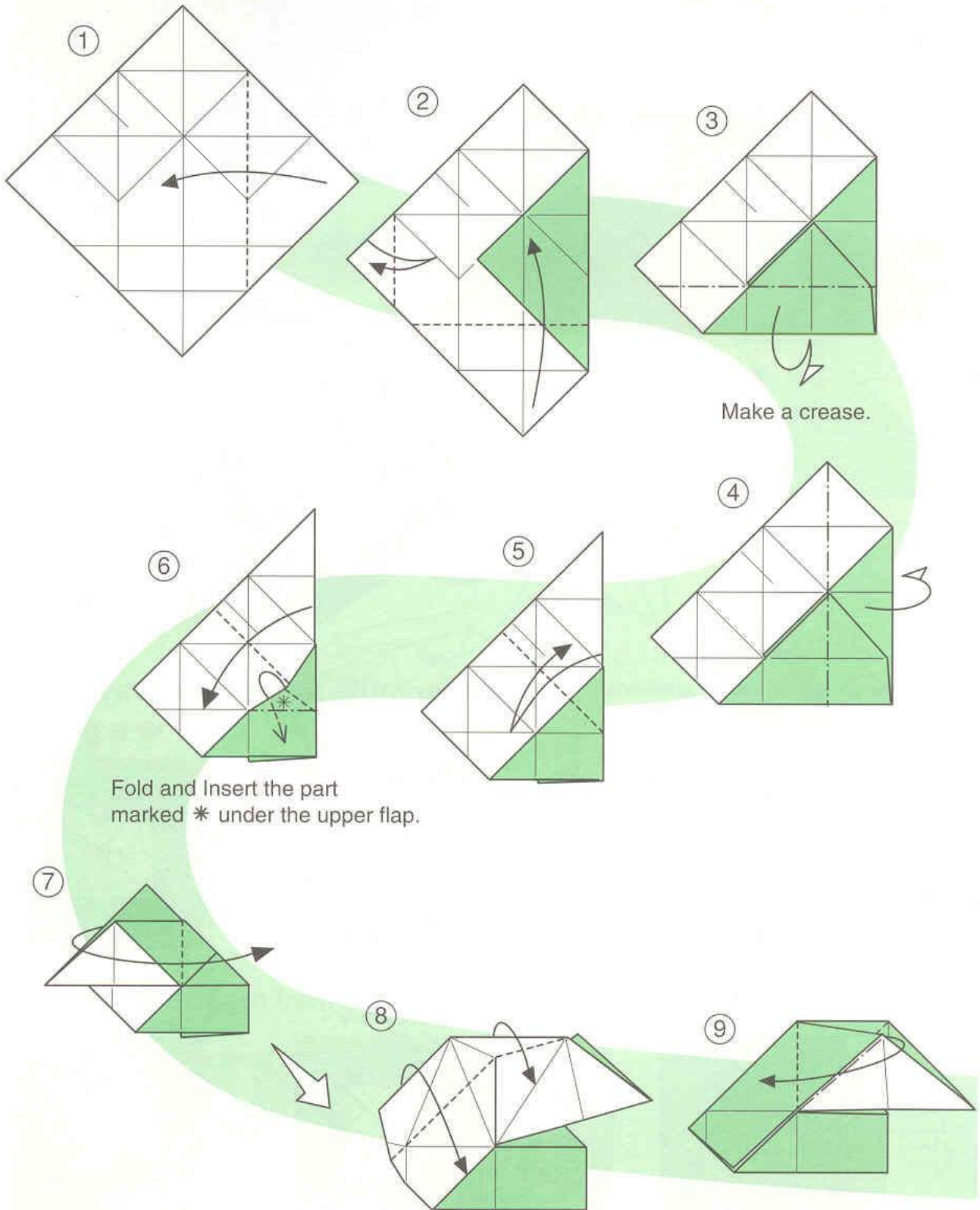

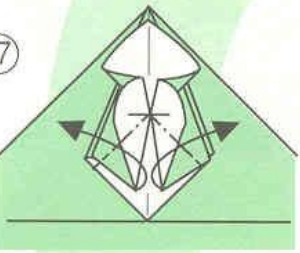
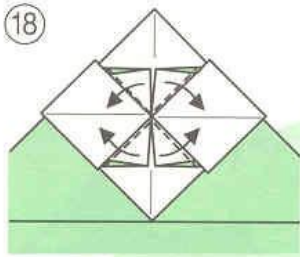

17

Open and flatten.

16

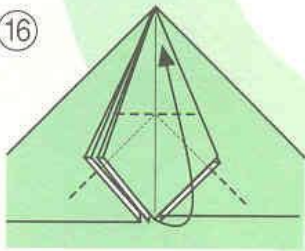

Fold up the top flap, opening petals.

Fold other three parts in the same way as steps 13 and 14.

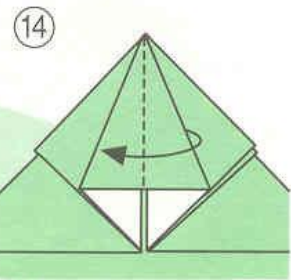
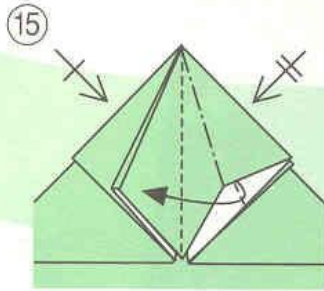

14

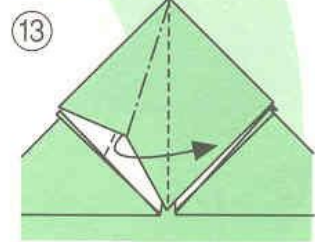

13

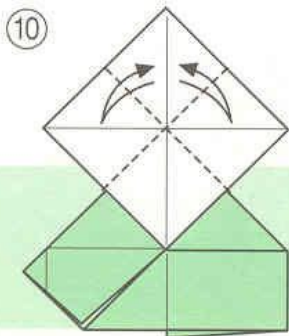

10

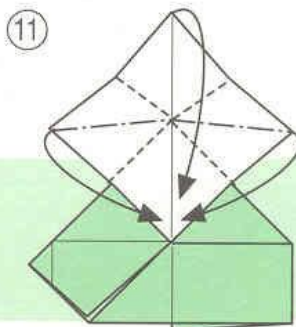

11

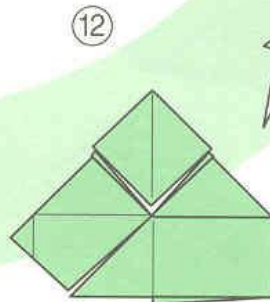

12

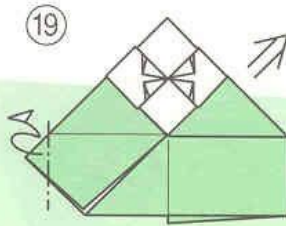

19



Make a crease on the left corner.
Open the back and lift up the sides.

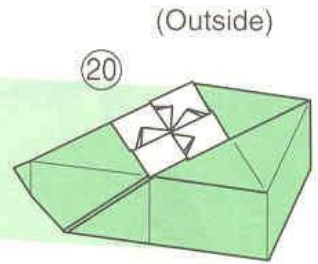

20

(Outside)

(× 4)

See the next page
for the assembly.

[Assembly]

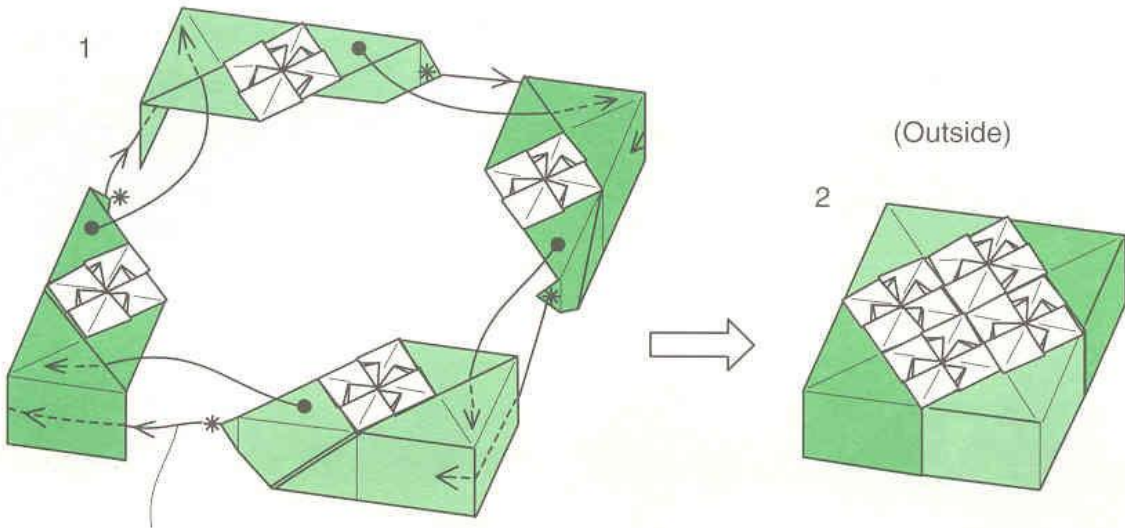

Fold the triangle * and lock firmly.

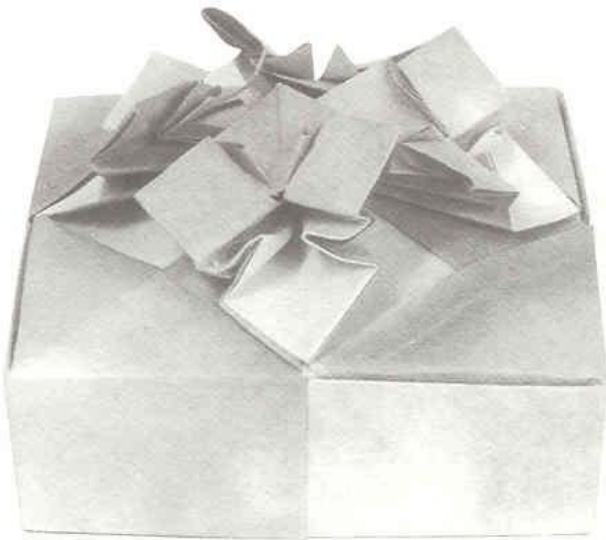

Square Boxes Plain 2 & Crane 2



◆ PLAIN 2 ◆

Begin with step ⑦ on page 64.

You may assemble plain boxes alone or join boxes with a crane.

The direction of crane 2 and crane 1 is opposite.

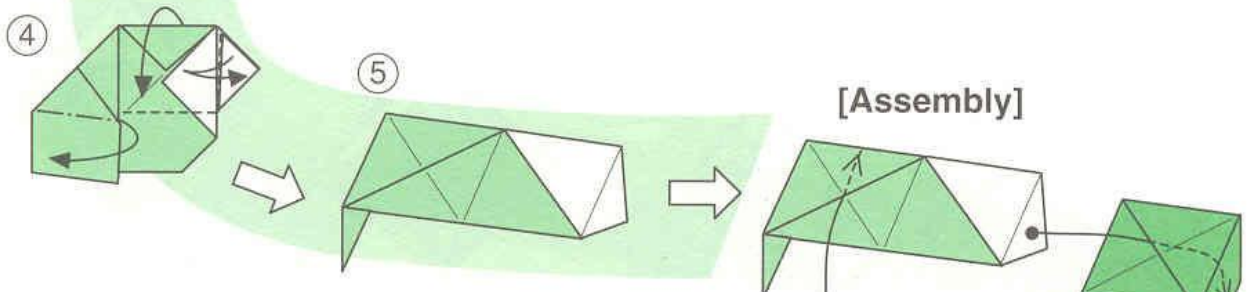
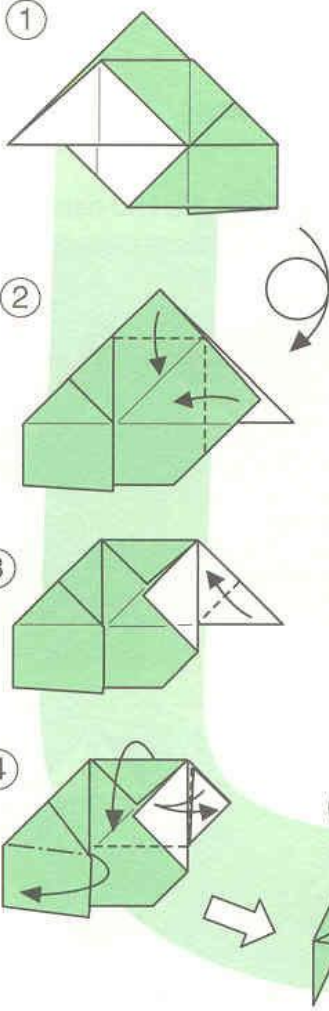

◆ CRANE 2 ◆

Begin with step ⑩ on page 65.

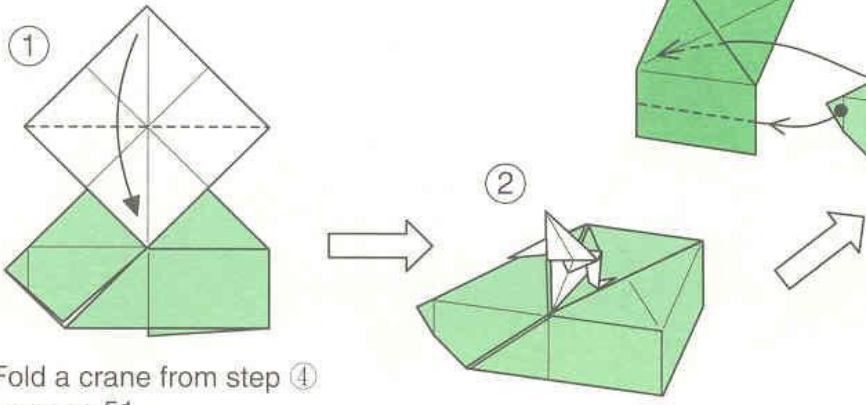

Fold a crane from step ④ on page 51.

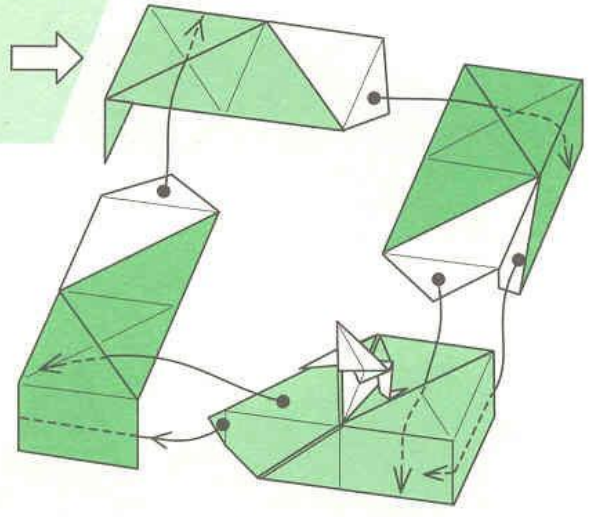

Square Box *Lily*

◆ LILY (traditional) ◆

The box has a lily on top.
 First learn how to fold a lily.
 Since the lily has many folds and becomes
 small, use larger paper.

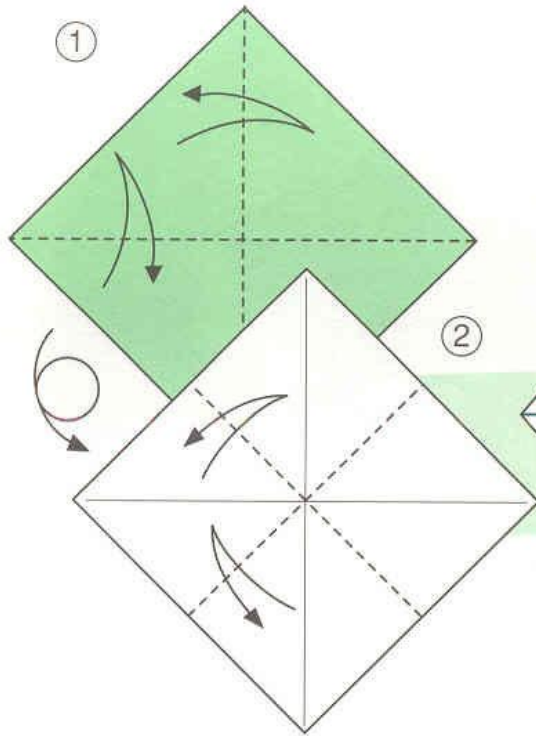

Fold up according to the creases.

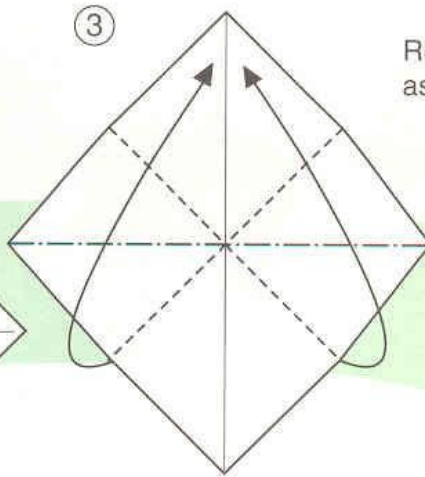

Repeat the fold behind
 as the one shown in front.

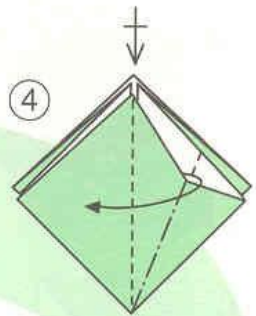

Open and flatten.

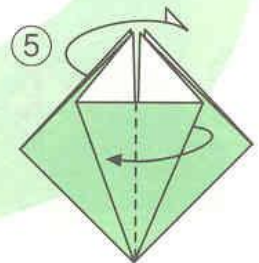
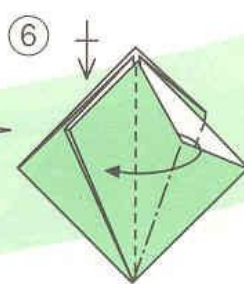
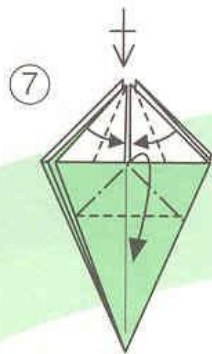
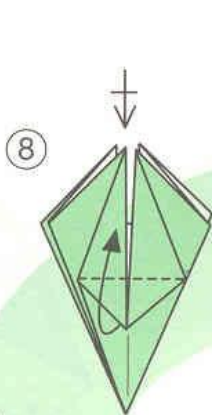

Turn the fold.

Repeat the fold behind
 as the one shown in front.
 Open and flatten.

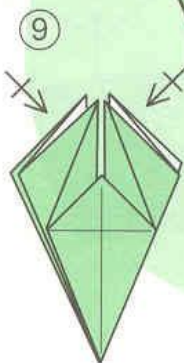

Fold the right and left
 in the same way.

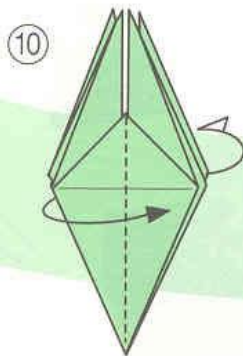

Turn the fold.

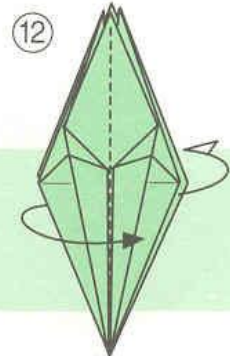
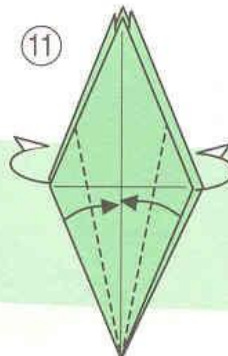

Turn the fold.

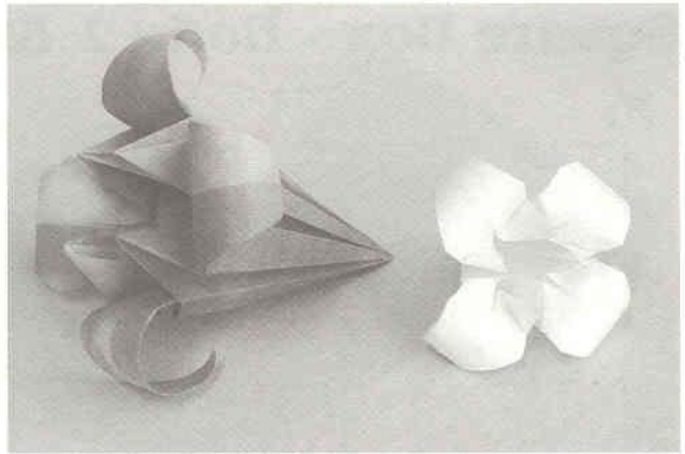
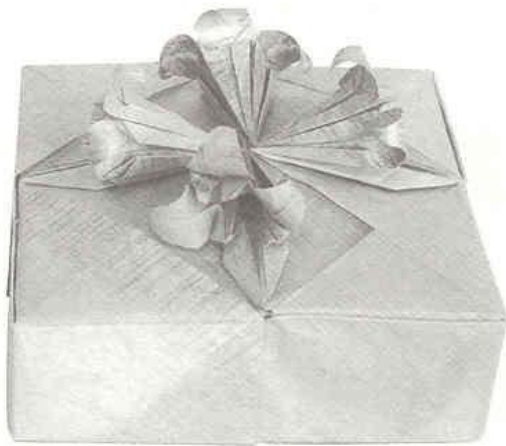

Begin with step ⑫ on page 65.

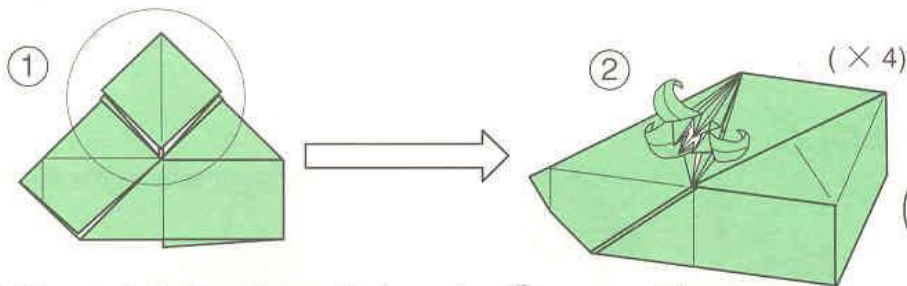

See page 66 for assembly.

Fold the encircled part into a lily from step ④ on page 68.

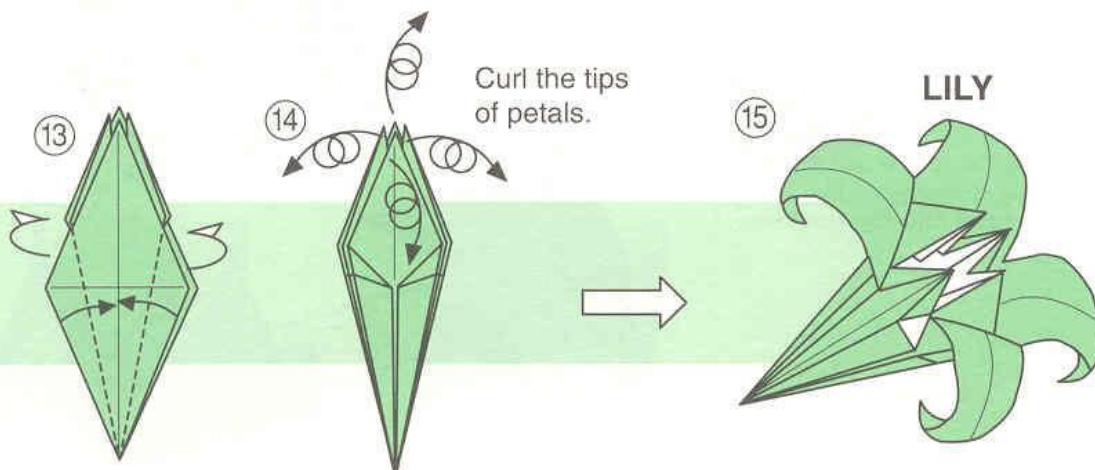

Square Box *Body 1 & Inside Liner*

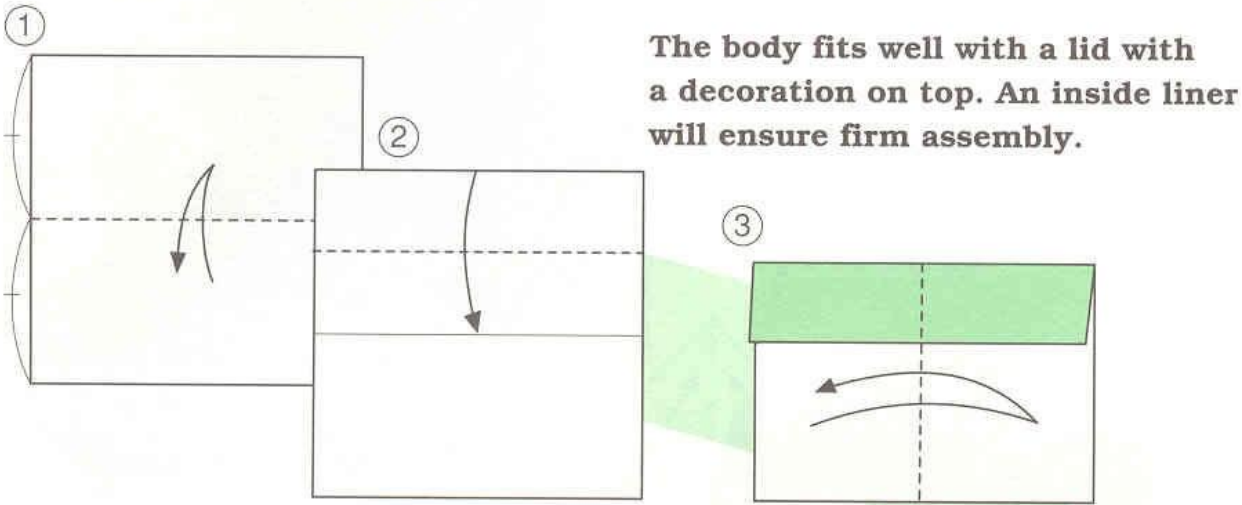

The body fits well with a lid with a decoration on top. An inside liner will ensure firm assembly.

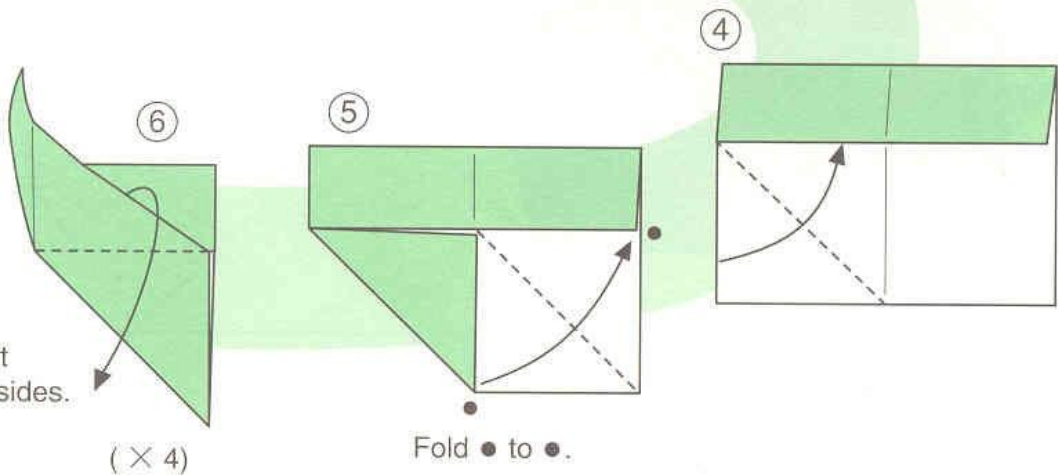

[Assembly]

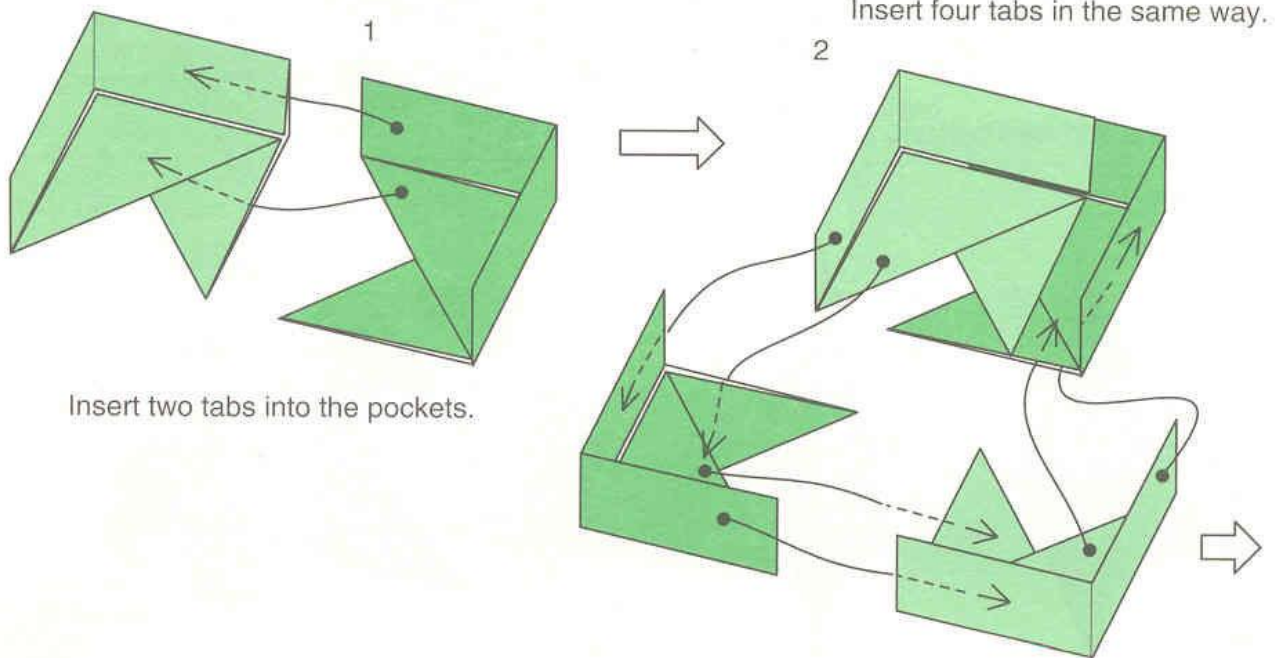

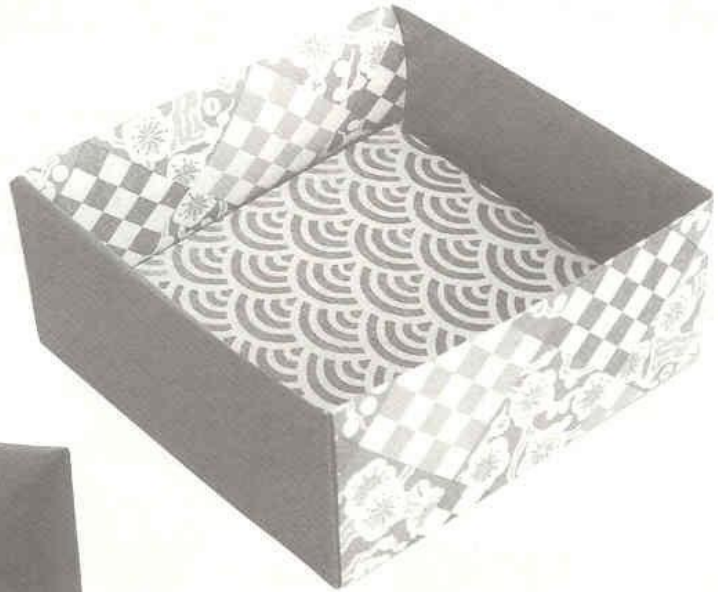

Body 1 & Inside Liner

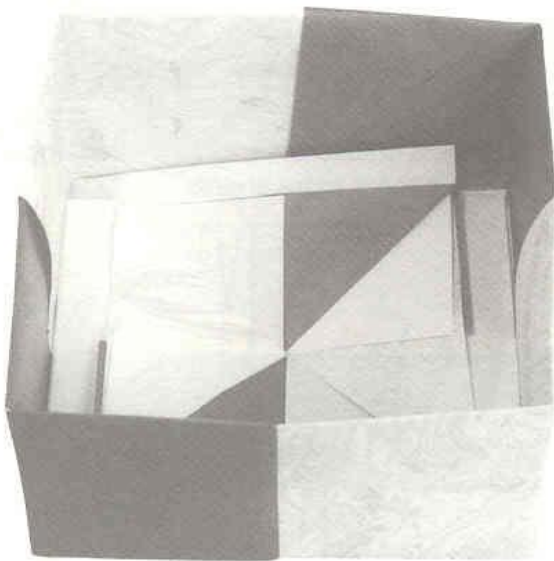

Body 2

◆ INSIDE LINER ◆

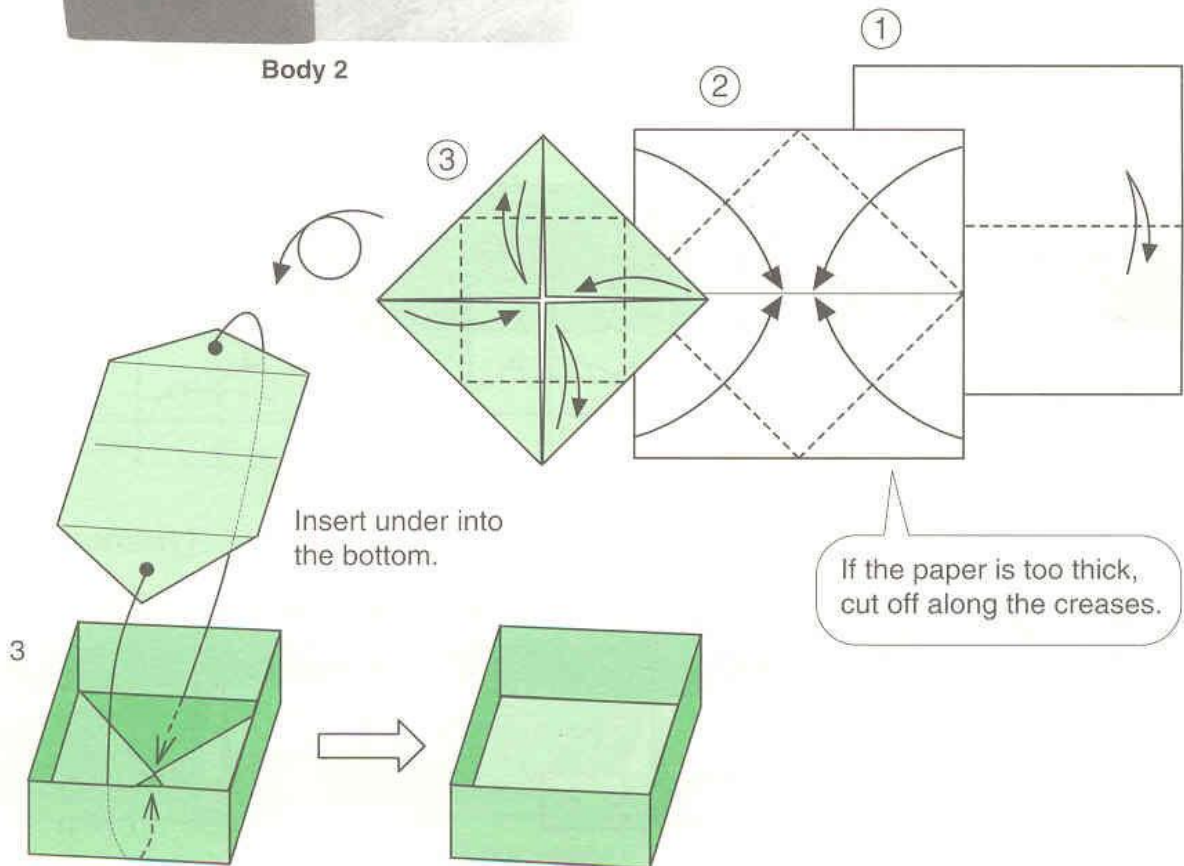

Square Box *Body 2*

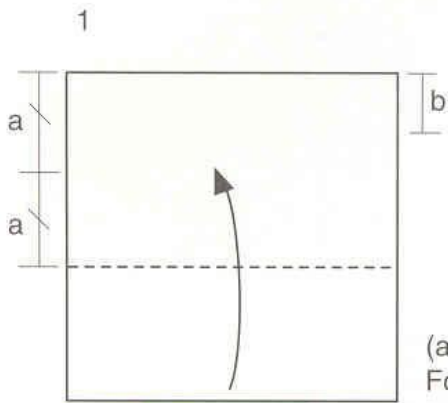

This box is deeper than Body 1.
 The depth depends on the width of the fold ①.
 Choose the depth as you like.

(a) is the depth of the box.
 Fold up leaving space (b) (1-2 cm).

2 [Template]

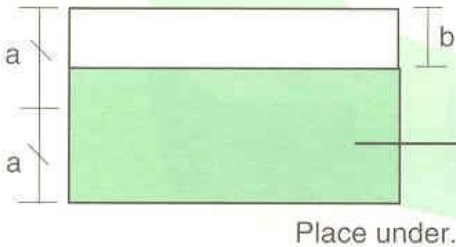

① Make the measurements from the template, and fold three more sheets.

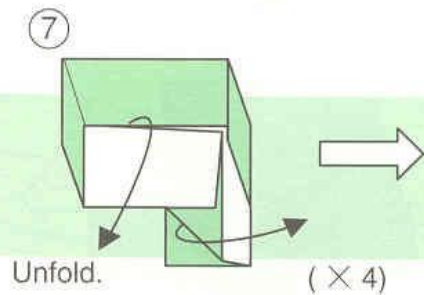
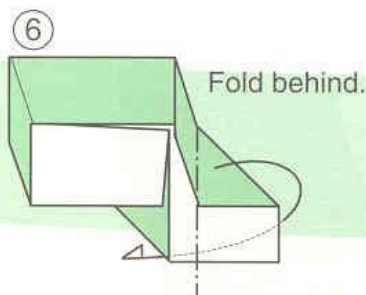
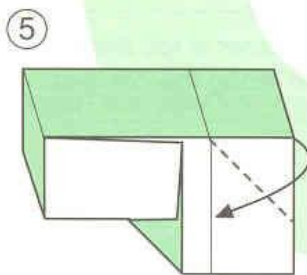
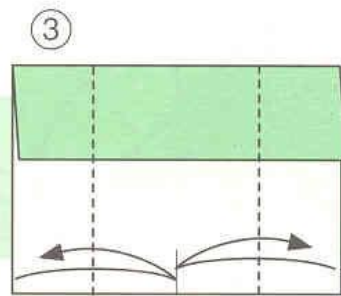
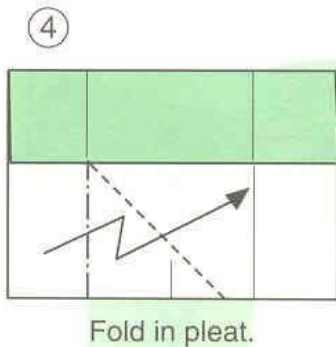
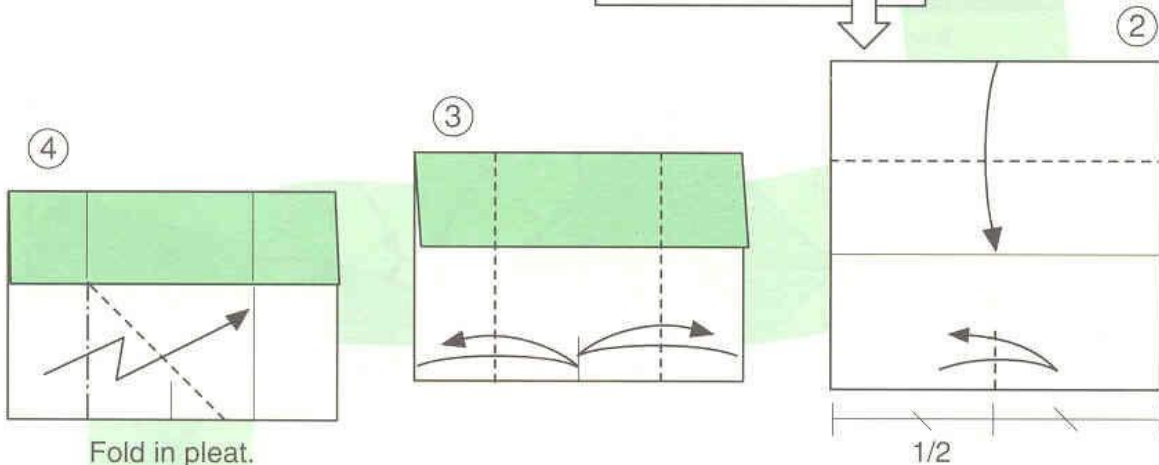
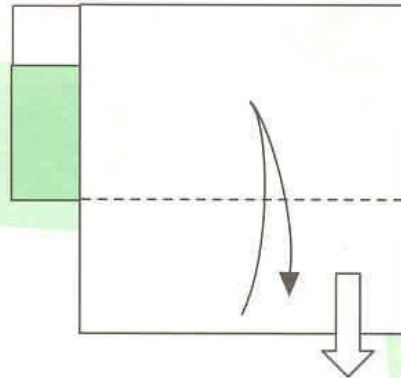

◆ **INSIDE LINER** ◆

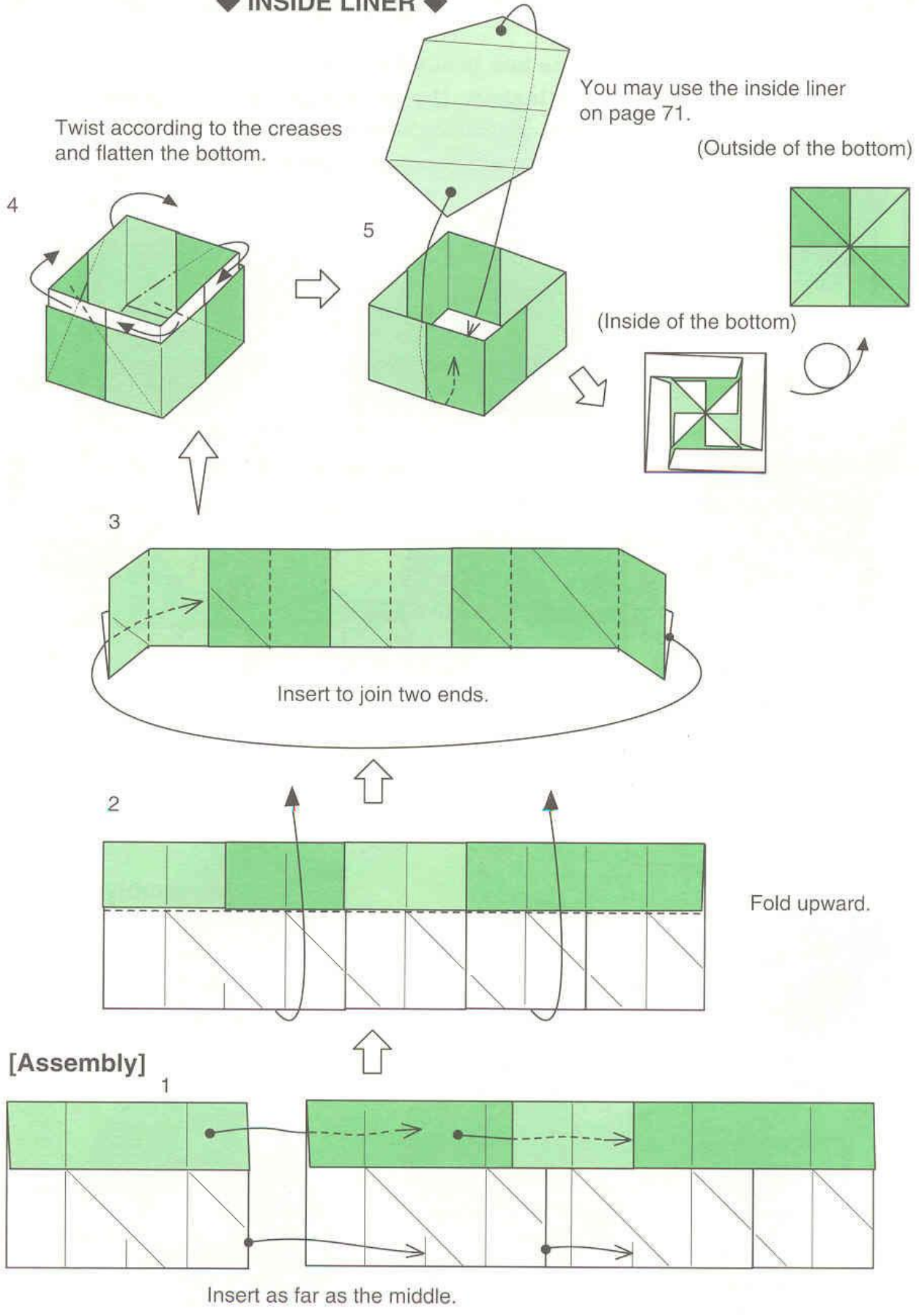

Square Box *Body 3*

This box is solid because both inside and outside are locked. If you change the folding width of ②, you can make nesting boxes. The size of the box is the same as size 1 on page 77.

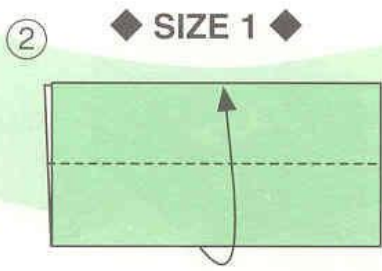
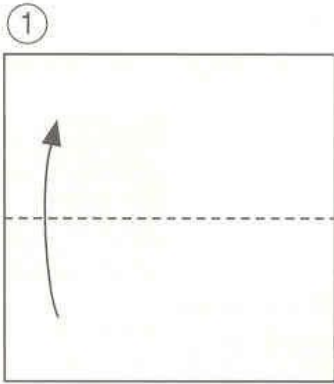

Unfold leaving the last flap as it is.

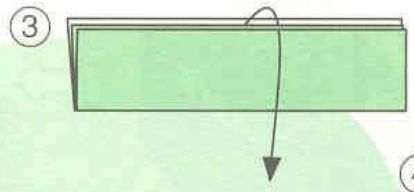

⑦ Make a crease at ○.

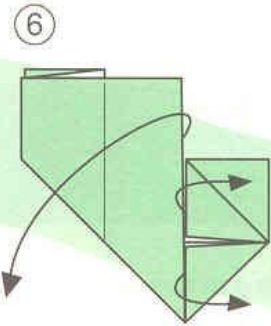
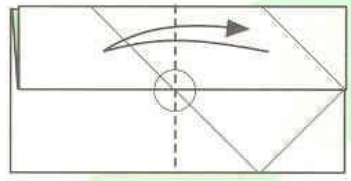

⑤ Change the direction.

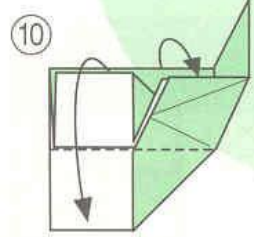
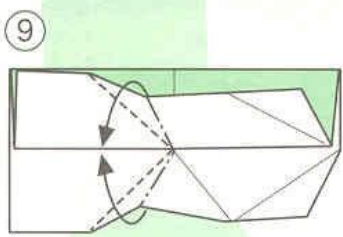
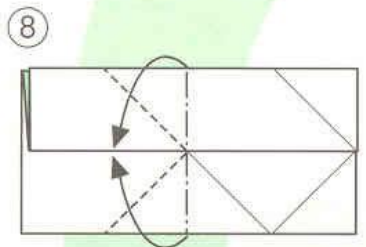
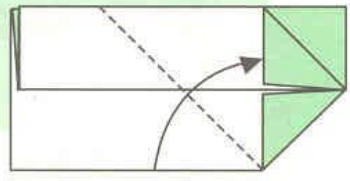

Fold down the bottom and lift up the sides.

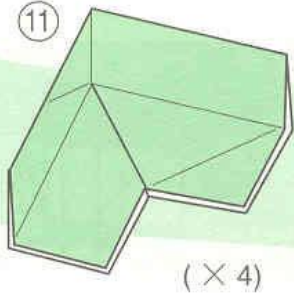

[Assembly]

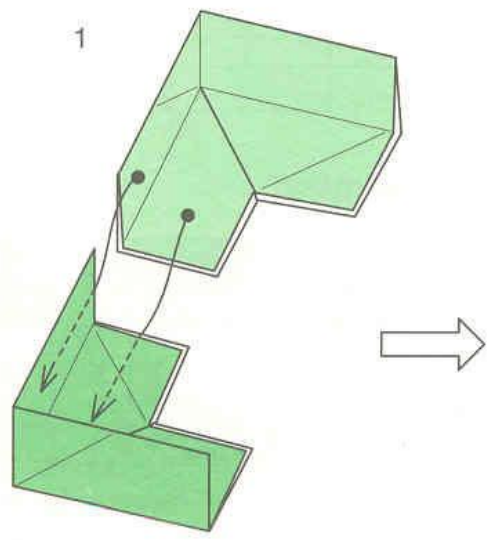

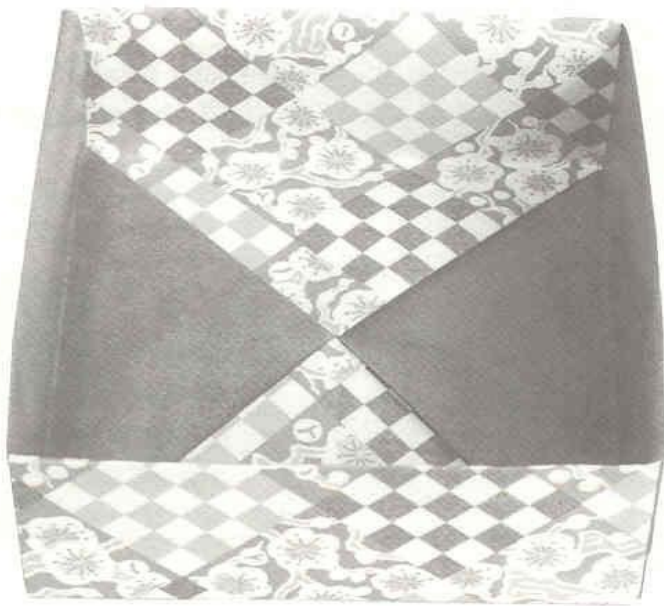

7 Turn over and lock the outside.

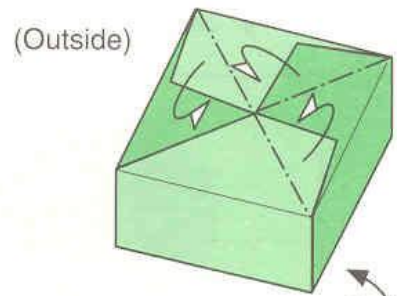

(Outside)

6

(Inside)

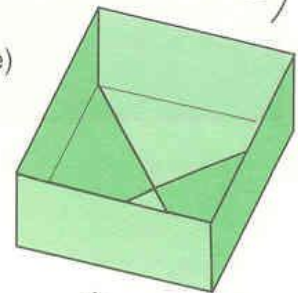

Lock the other three parts in the same way.

5

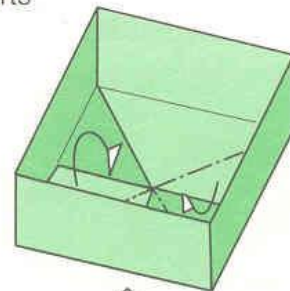

3 Turn over and insert the flap and lock.

3

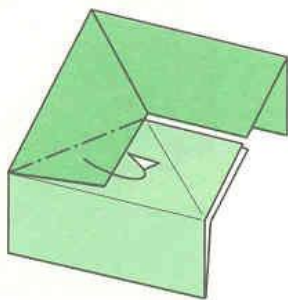

2

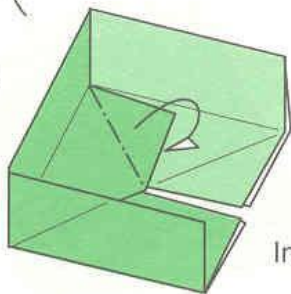

Insert the flap and lock.

4

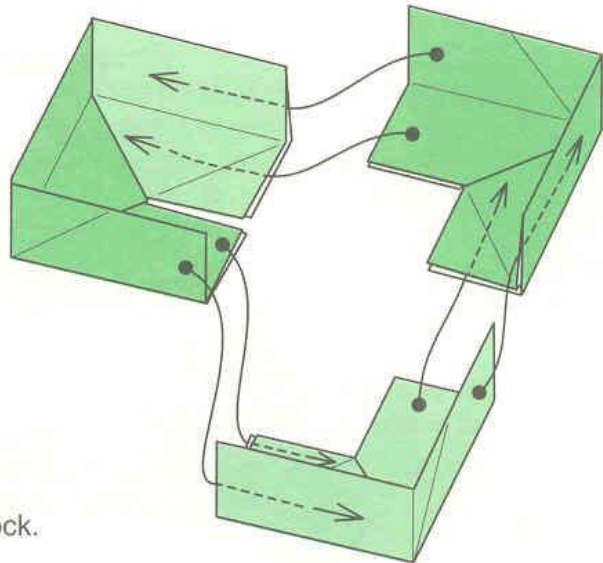

Square Boxes *Body & Nesting Boxes*

◆ SIZE 9 ◆

Adjust the width in steps ② and ③ to make nesting boxes.

Introduced in this page are boxes, size 9 and size 5 listed in the measurement list on the next page.

Unfold leaving the last flap as it is.

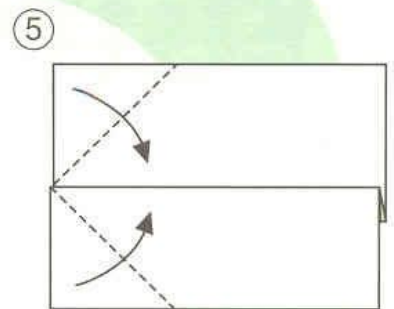
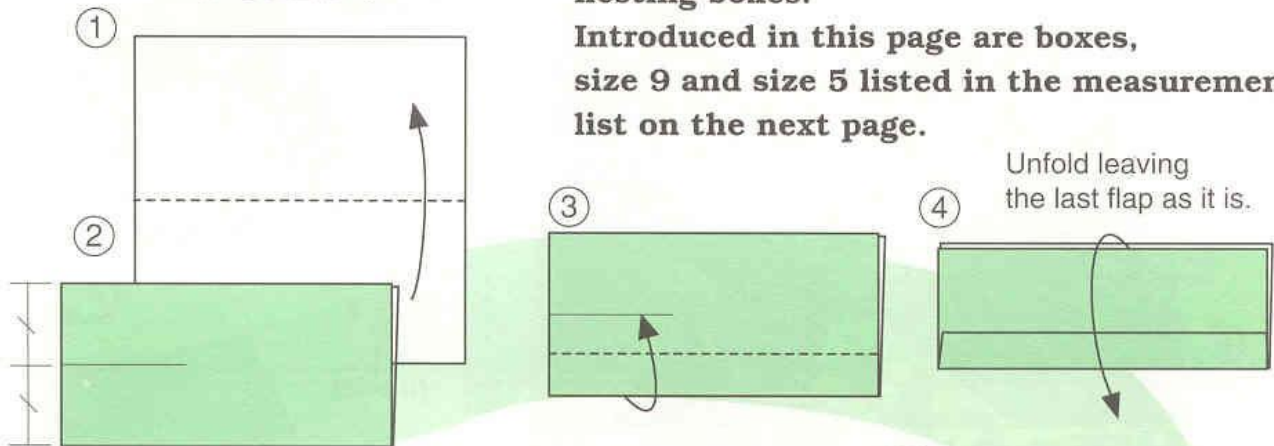

⑥ Change the direction.

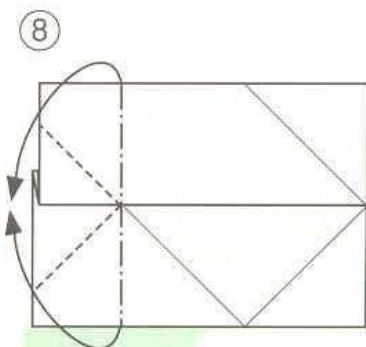
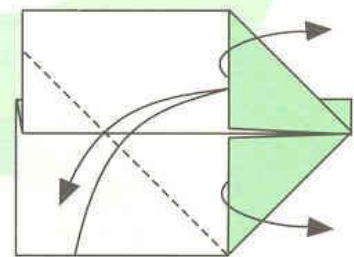

⑦ Make a crease at ○.

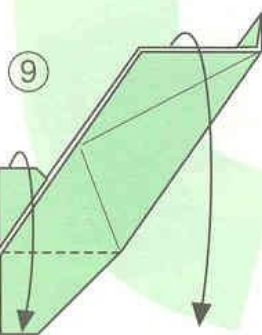
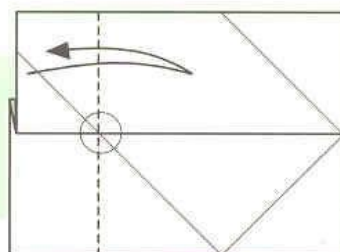

Fold down the bottom and lift up the sides.
(× 4)

[Assembly]

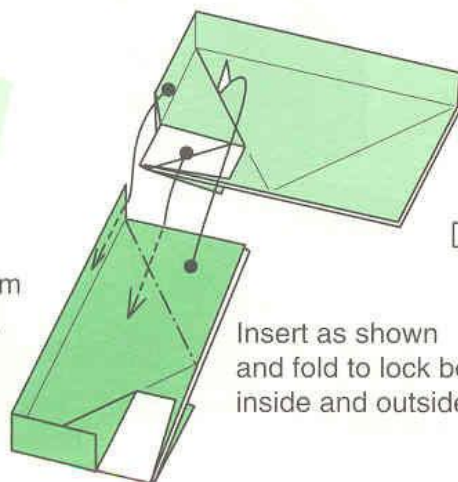

See page 75 for assembly.

Insert as shown and fold to lock both inside and outside.

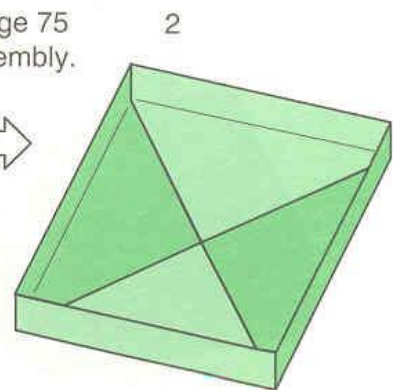

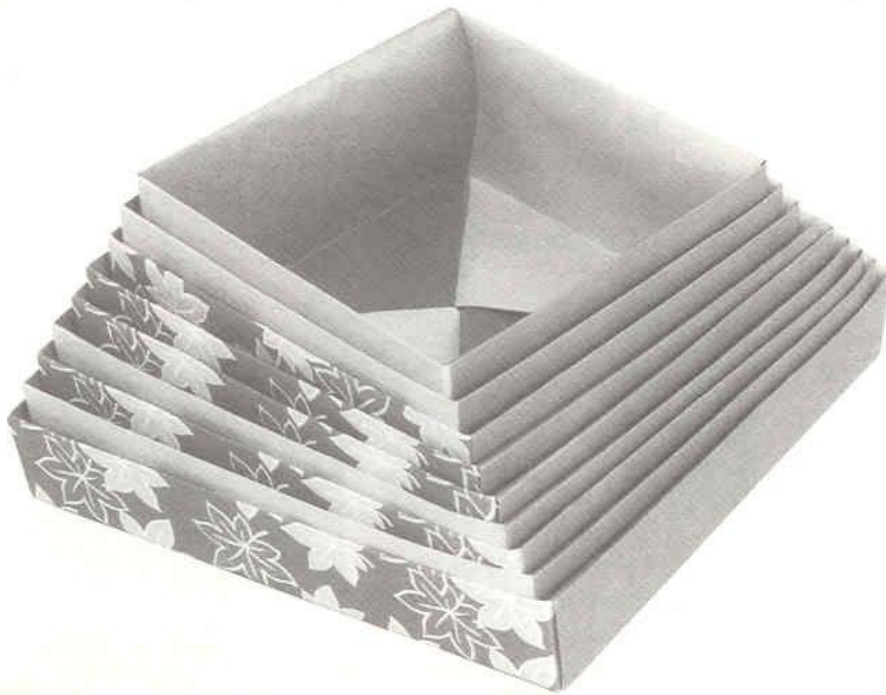

① ◆ SIZE 5 ◆

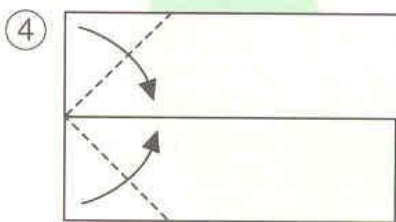
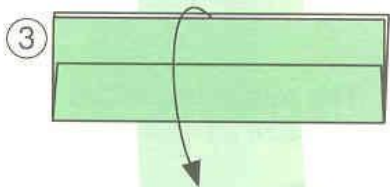
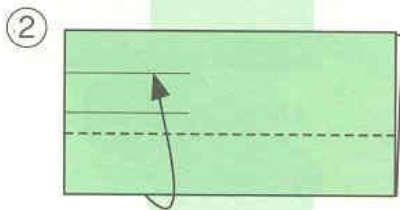
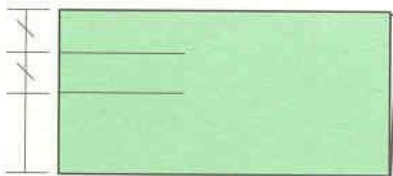

Fold and assemble
as shown on page 75.

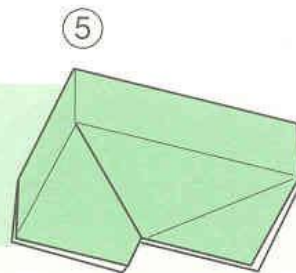

(× 4)

◆ List of Measurements ◆

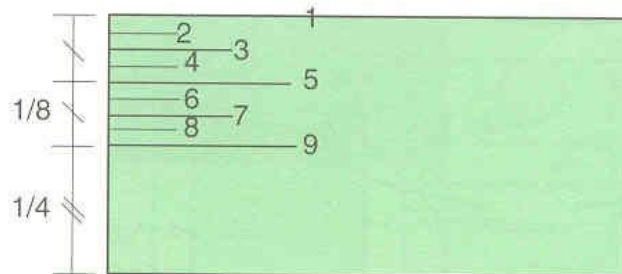

The lines show places the edges are fold to in
steps ② and ③.

The higher the number is, the shallower and
larger the boxes become.

Nine nesting boxes will be made in all.

Rectangle Box *Individual Plate*

◆ BASIC ◆

This rectangle box is made up of a single sheet of paper. The size of the basic rectangle box will be about 2/3 of a square box and will fit in the square box. If you change the folding width in the first step, you can make other rectangle boxes of different sizes.

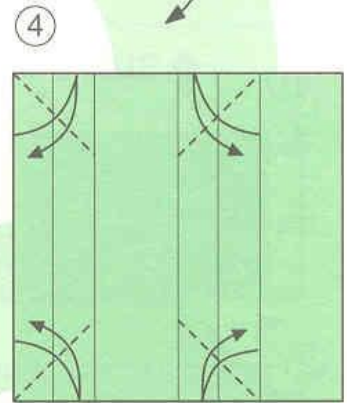
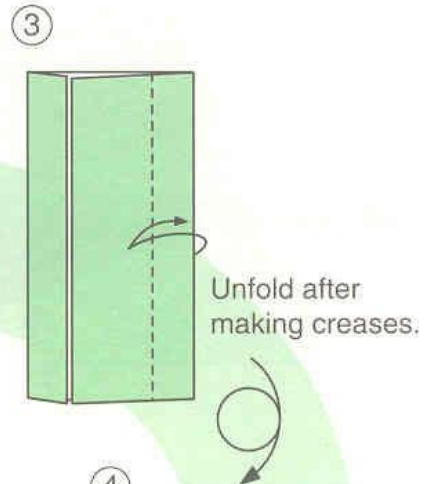
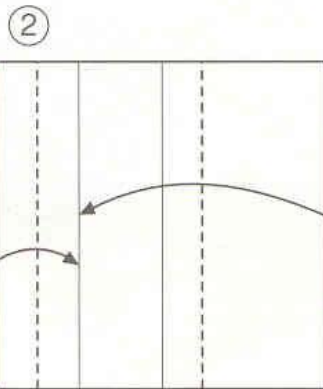
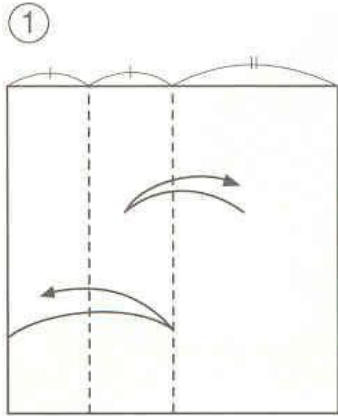

Make creases as shown.

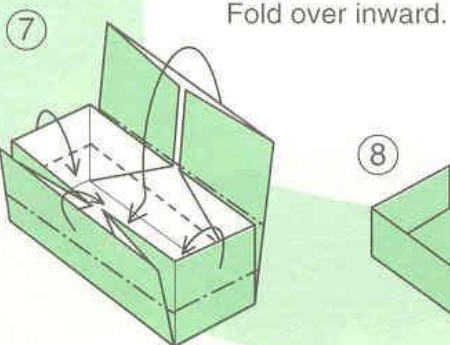
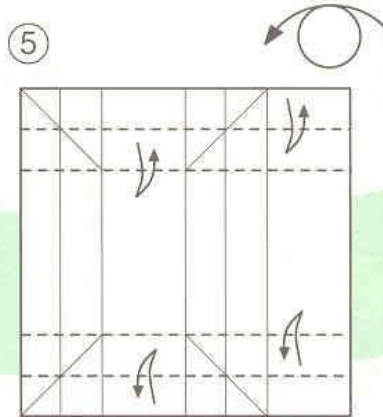
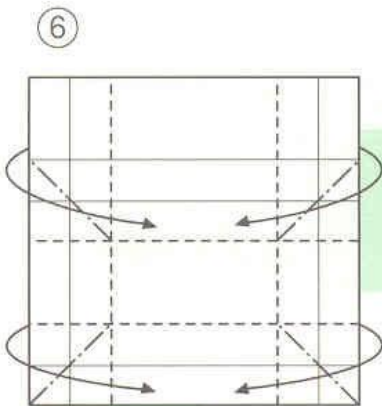

The square box folded with size 2 on page 77.

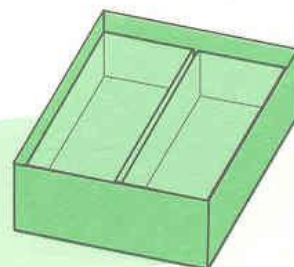
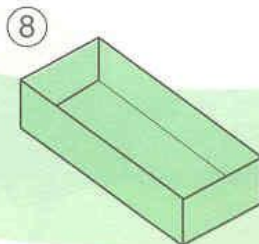

◆ Smaller than basic — BODY ◆

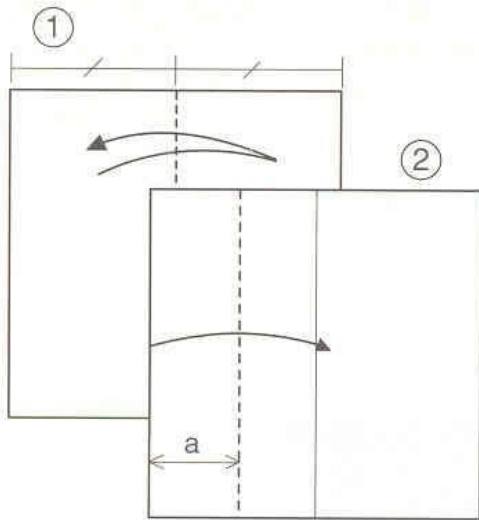

The sizes of boxes depends on the folding widths of ②.

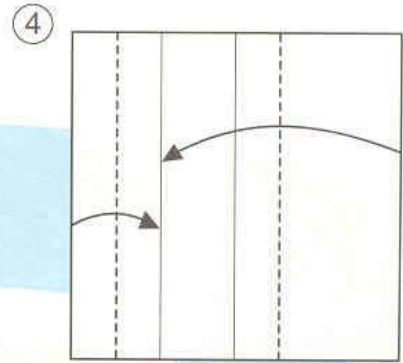
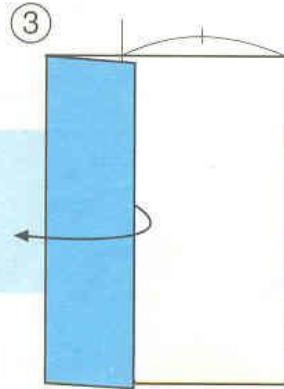

Fold so that the edge sticks out a little from the center.

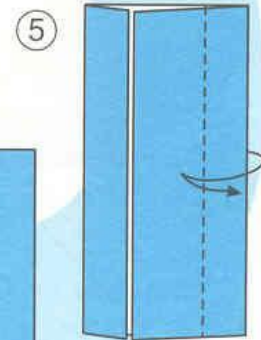

If (a) is longer than 1/4, the box will be smaller and deeper.
If (a) is shorter than 1/4, the box will be larger and shallower.

The rectangle box on page 78 will fit as a lid.

Cover.

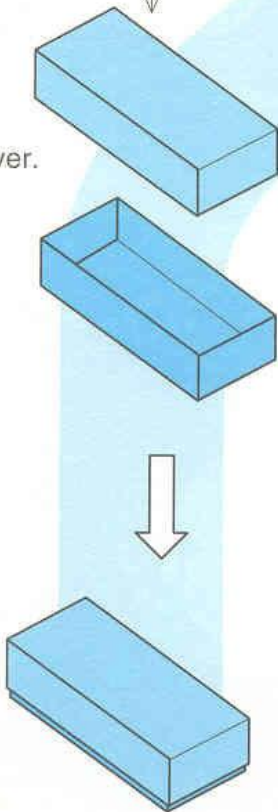

Continue with steps ⑤ to ⑧ on page 78.

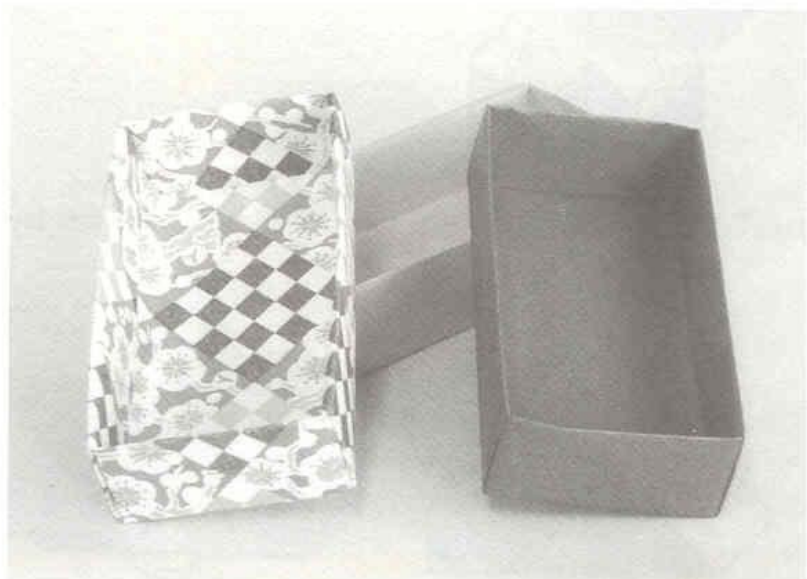

Octagon Box *Small Flower (A)*



A neat and firm octagon box made up of 4 sheets of paper.

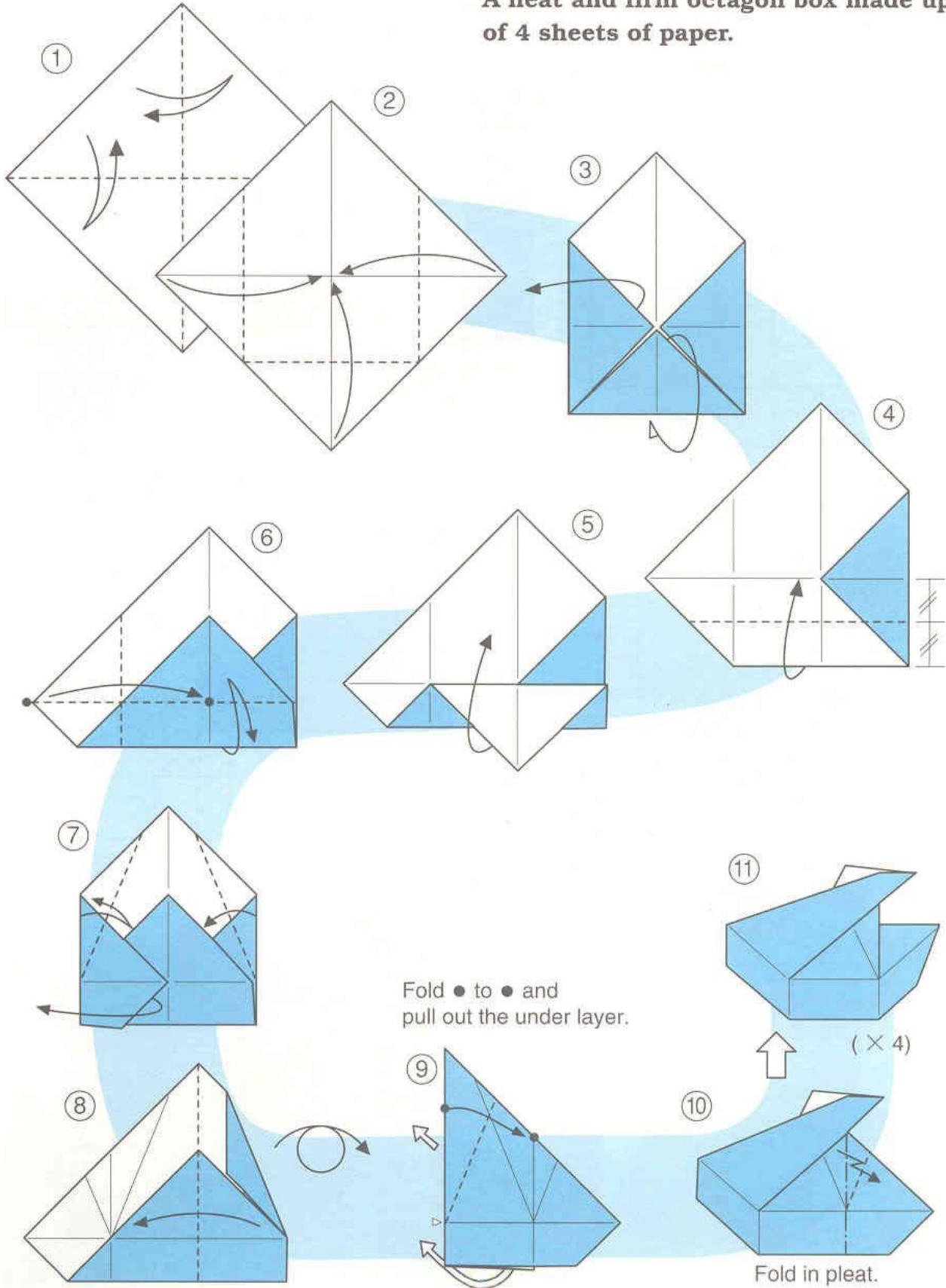

Fold ● to ● and pull out the under layer.

Fold in pleat.

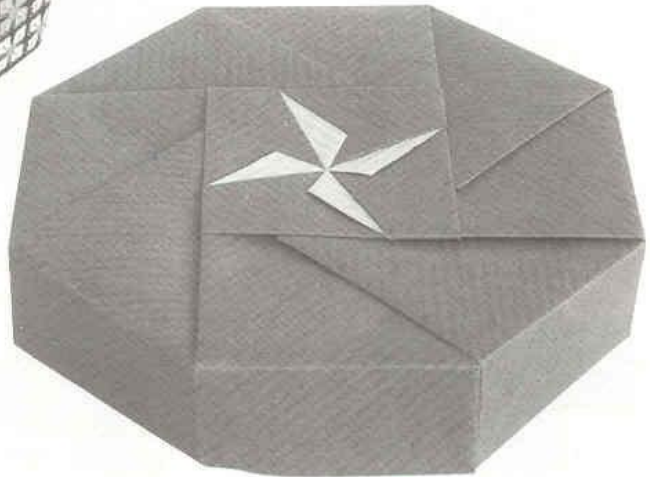
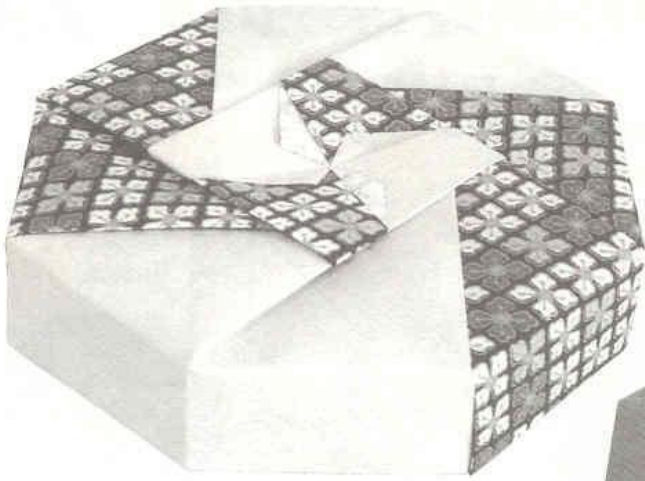

Small Flower (A)

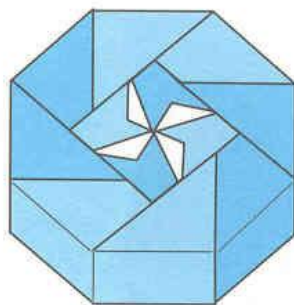

Lock each point by folding it inward.

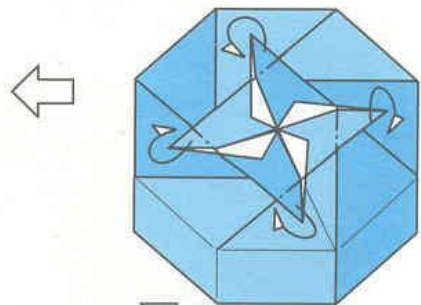

[Assembly]

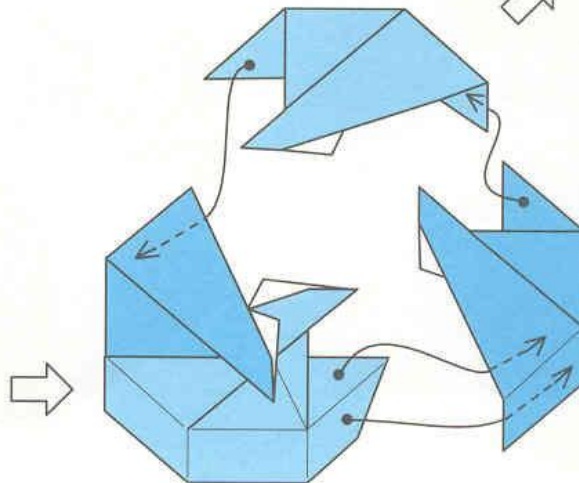
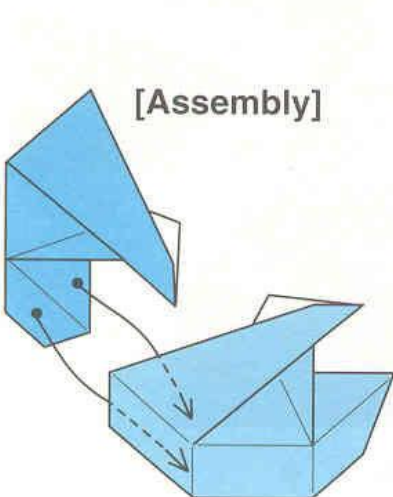

Join the four units as shown.

Variations of Small Flower (A) - a, b



If you alter the folding a little, you can get different patterns.
 Box (b) has "Small Flowers" inside.

◆ a ◆

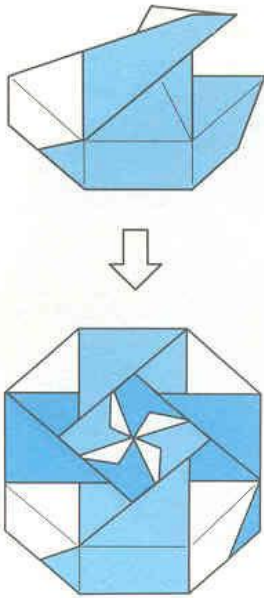

◆ b ◆

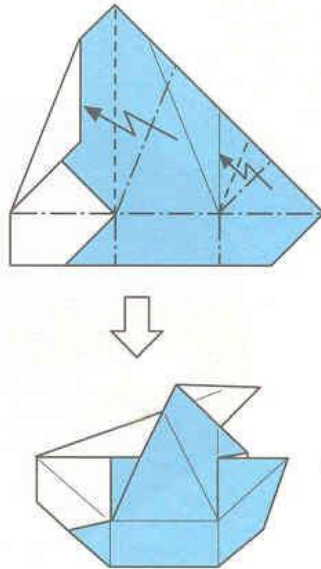

(Inside)

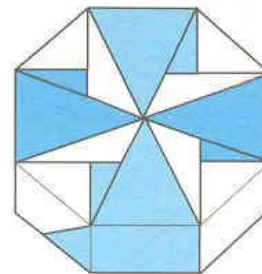
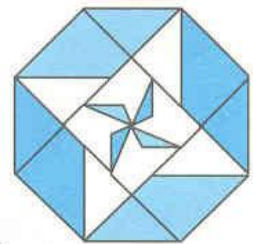

Inside the box, lock each point by folding it inward.

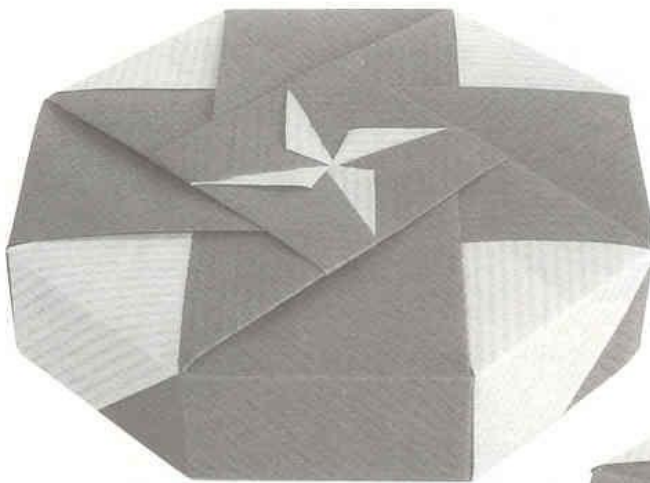

◆ a ◆

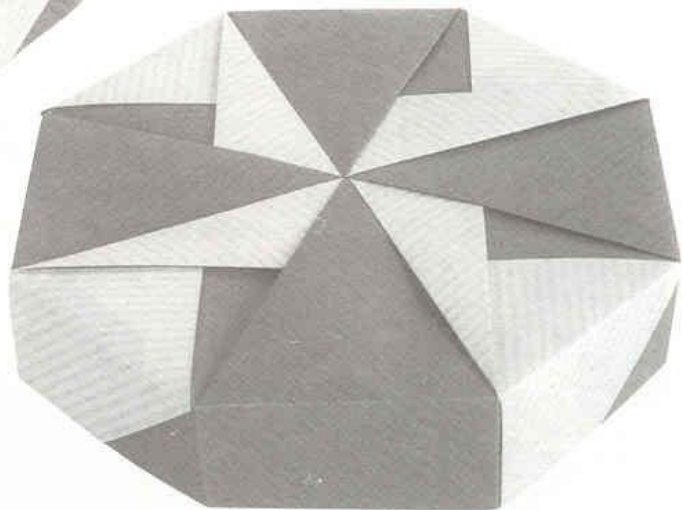

◆ b ◆

Octagon Box *Small Flower (B)*



The direction of the decorations on top is different from that of "Small Flower (A)." You will be pleased with various patterns (see page 84).

Begin with step ⑦ on page 80.

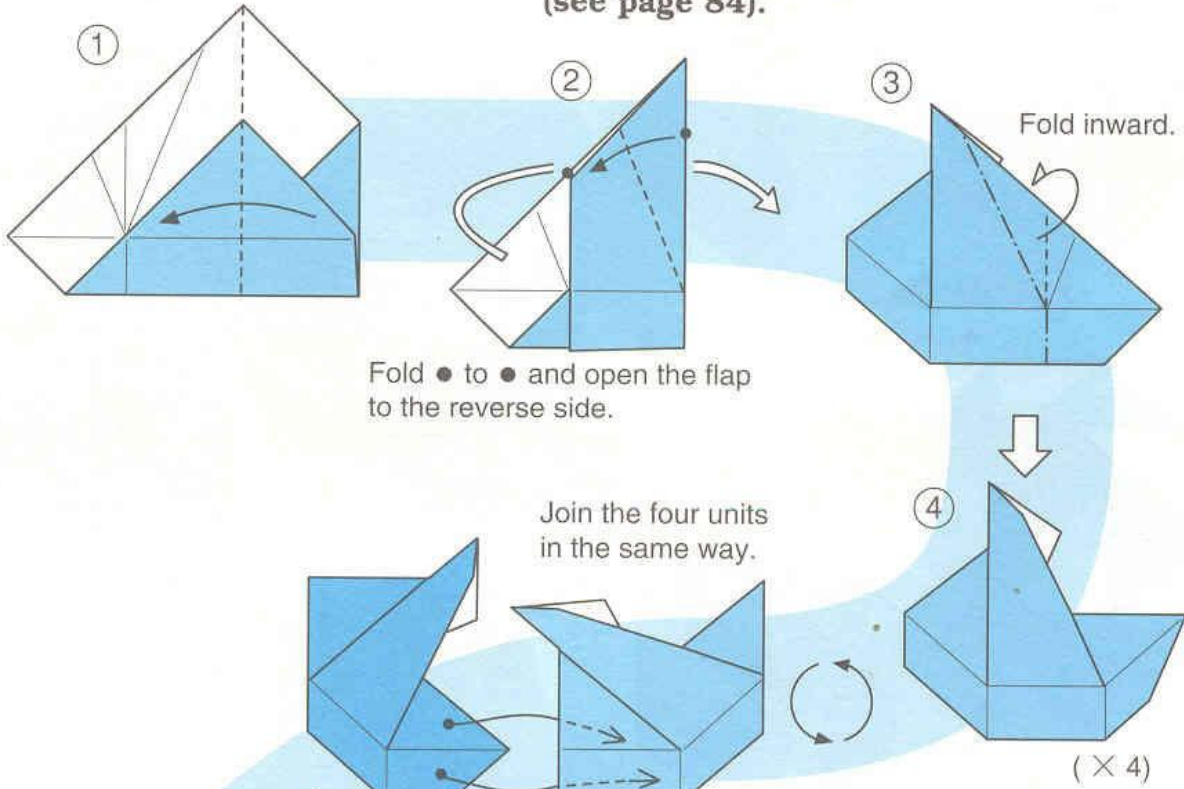

Fold ● to ● and open the flap to the reverse side.

Join the four units in the same way.

Lock the outside as "Small Flower (A)" on page 81.

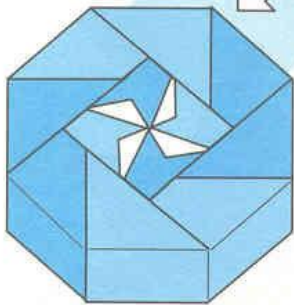

Small Flower (B)

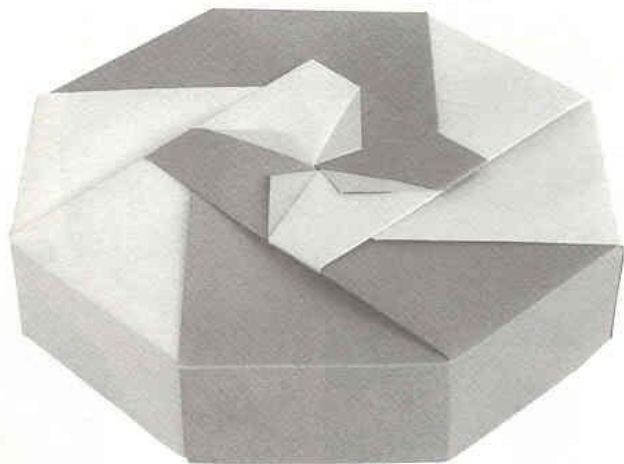

Variations of Small Flower (B) - a, b, c, d

a

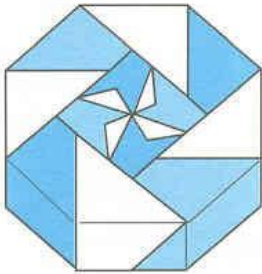
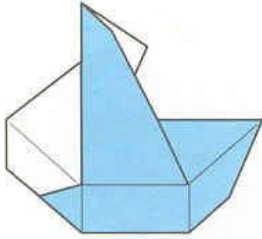

b

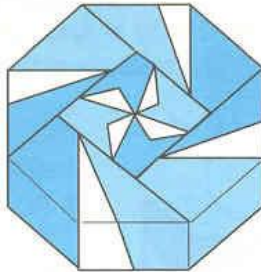
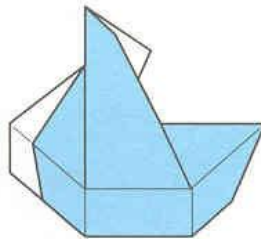

c

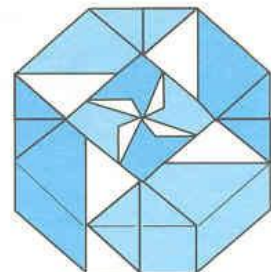
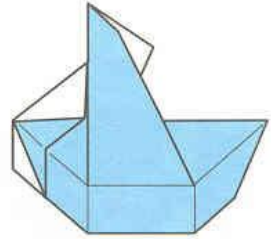

a + b

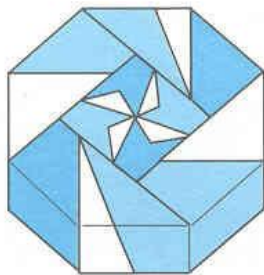

It is possible to assemble with different units.

Small Flower (B)

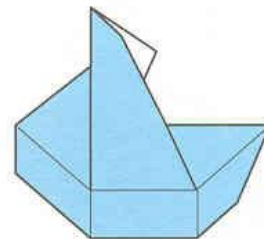

d

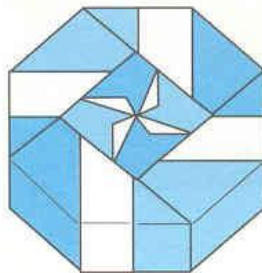
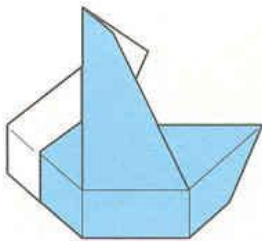

b + Small flower (B)

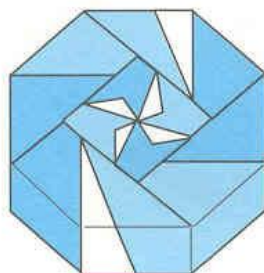

d + Small flower (B)

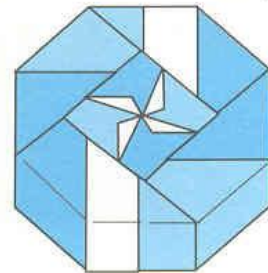

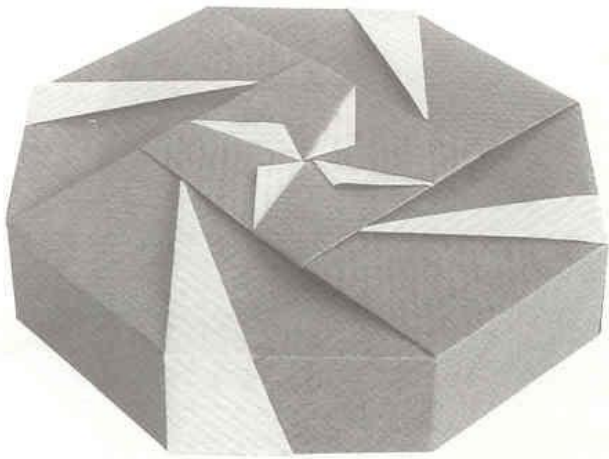

◆ b ◆

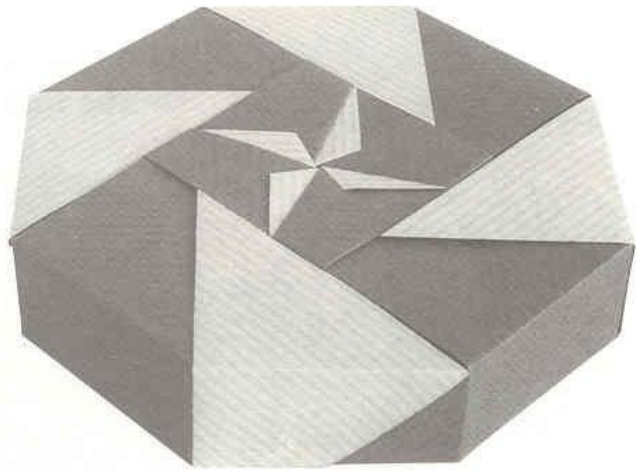

◆ a ◆



◆ d ◆

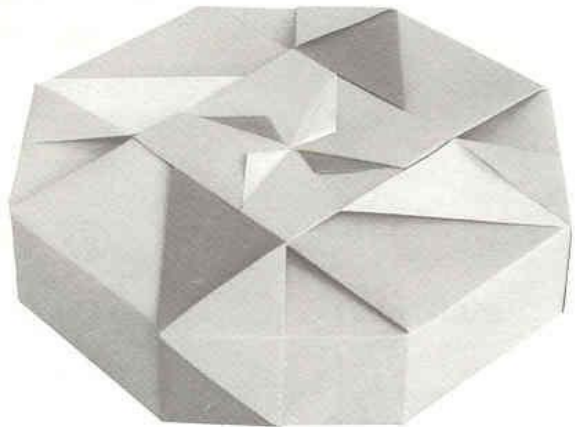

◆ c ◆

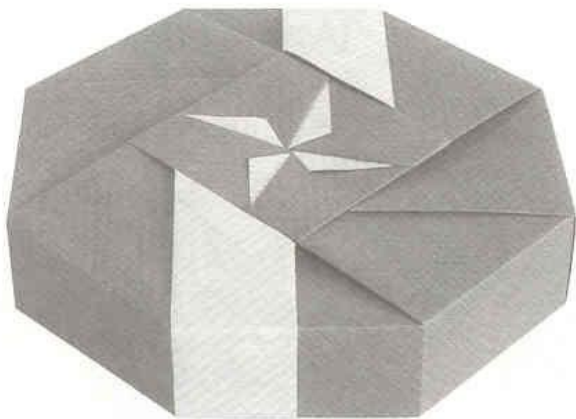

◆ d+Small Flower (B) ◆



◆ a+b ◆

Octagon Box *Twin Stars*



Turn over the "Small Flower" and fold so that the inside turns into the outside.

Begin with step ⑥ on page 80.

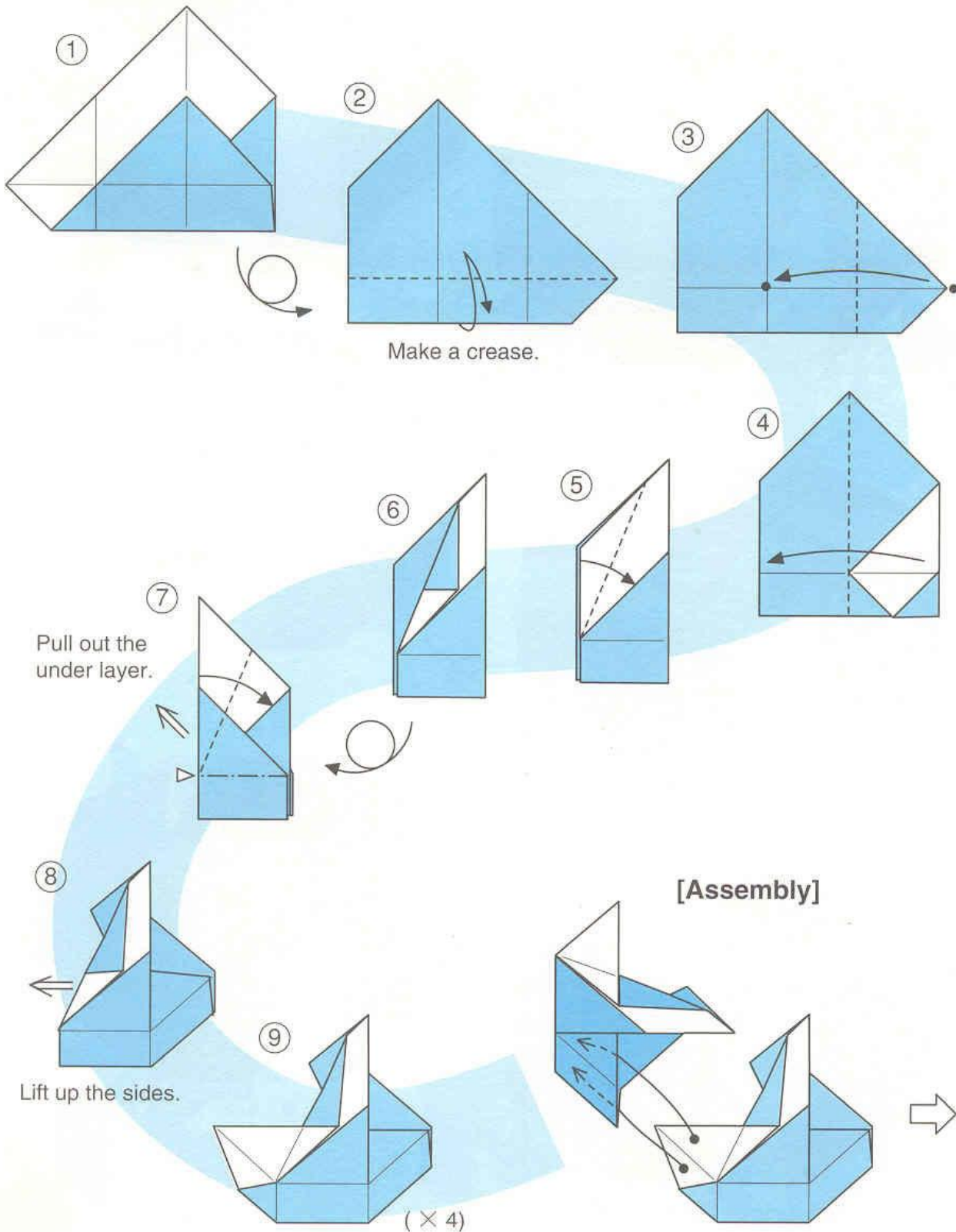



Twin Stars

Join the four units as shown.

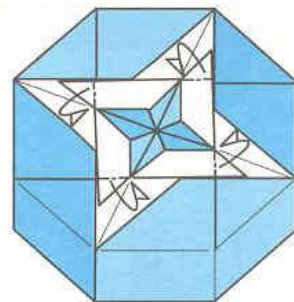
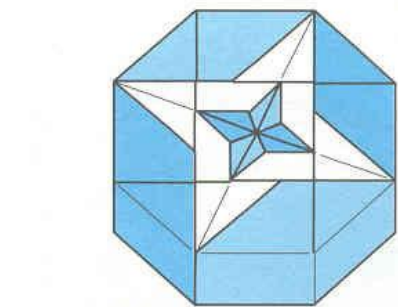
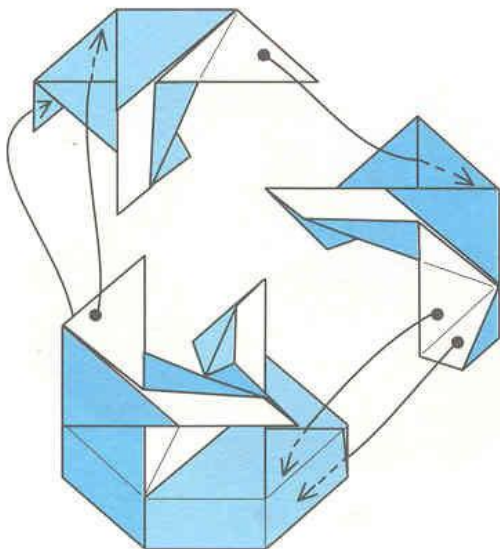

Lock each point by folding it inward.

Variations of Twin Stars - a, b, c

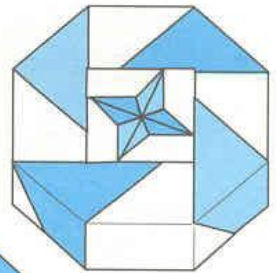
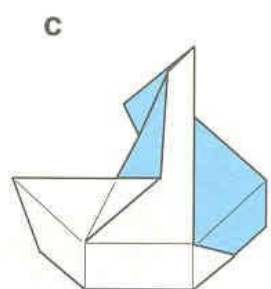
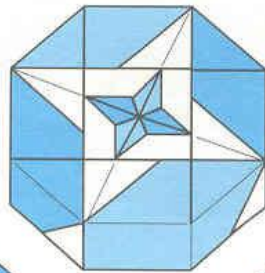
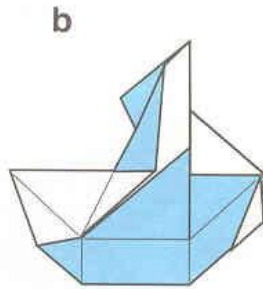
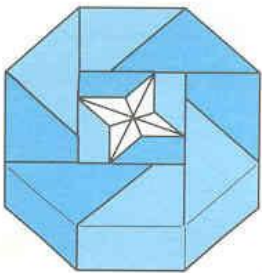
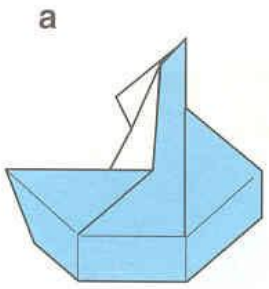

a + b

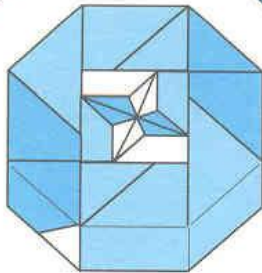

b + c

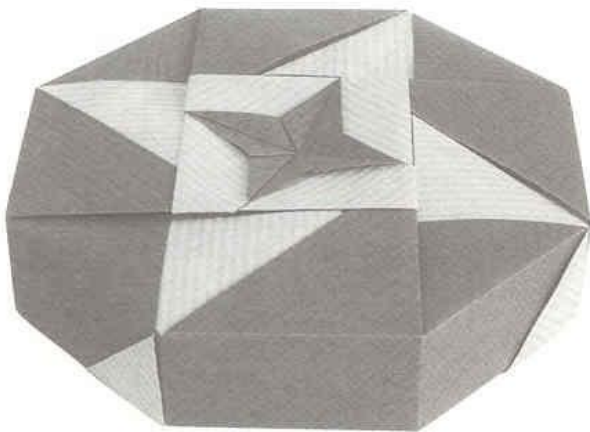
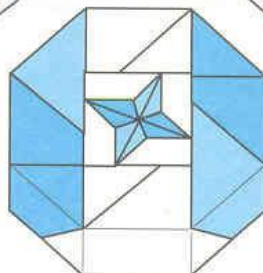

◆ b ◆

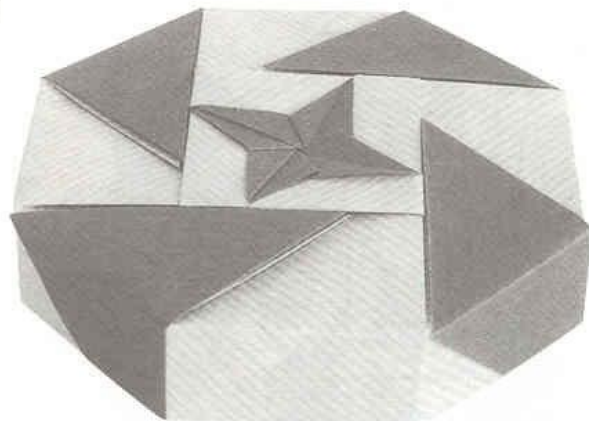

◆ c ◆

Octagon Box Plain

A plain box with the patterns appearing on the inside.

Begin with step ⑦ on page 80.

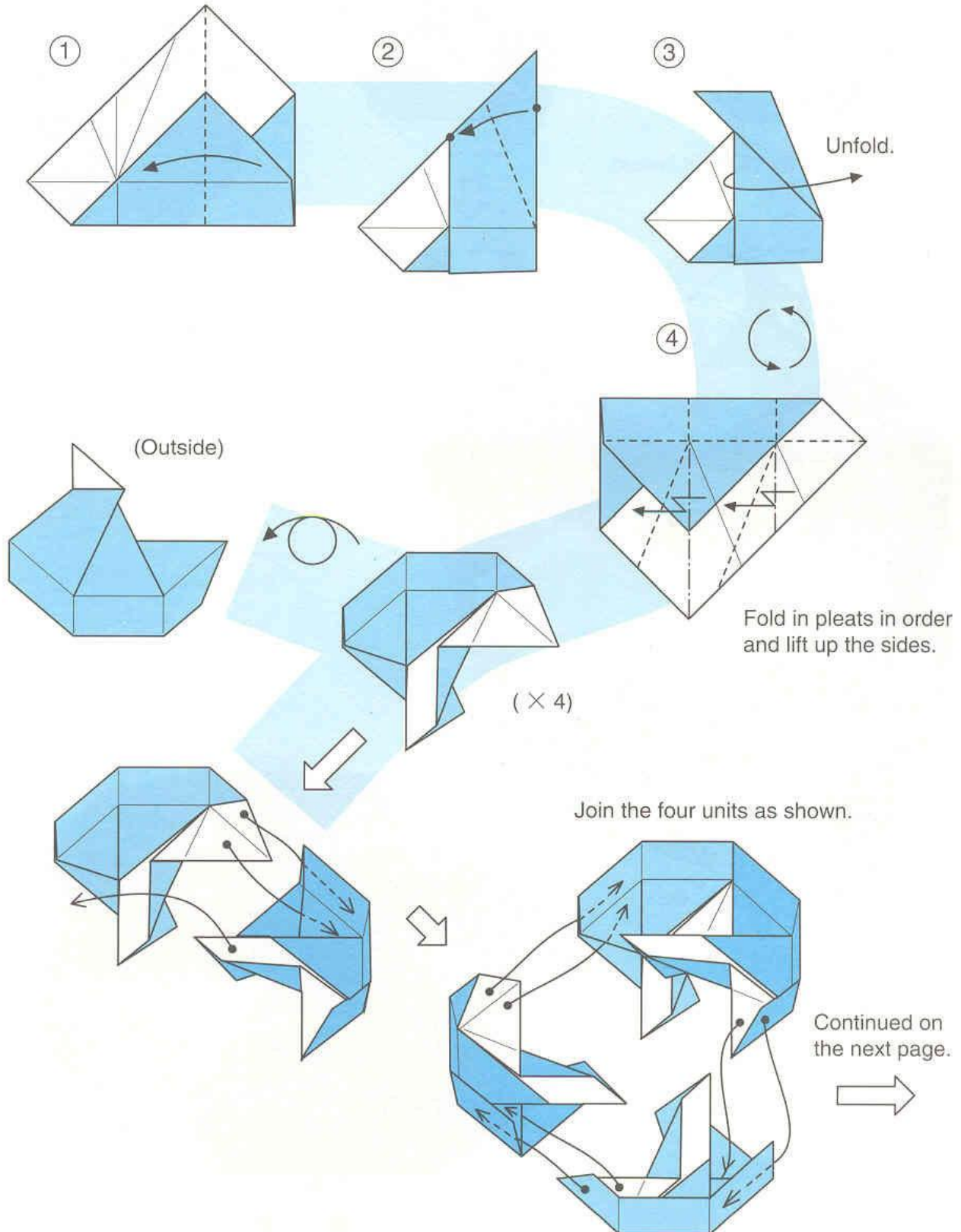

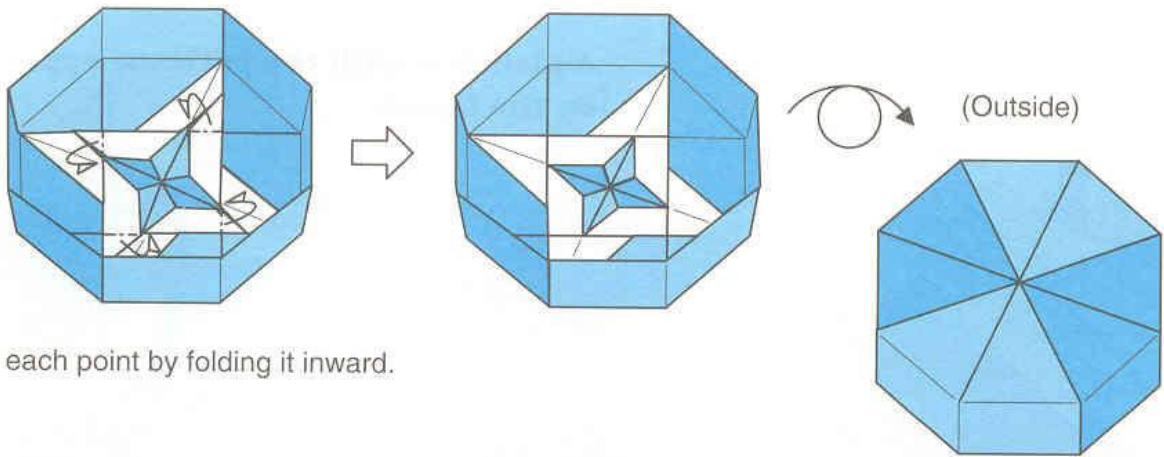

Lock each point by folding it inward.

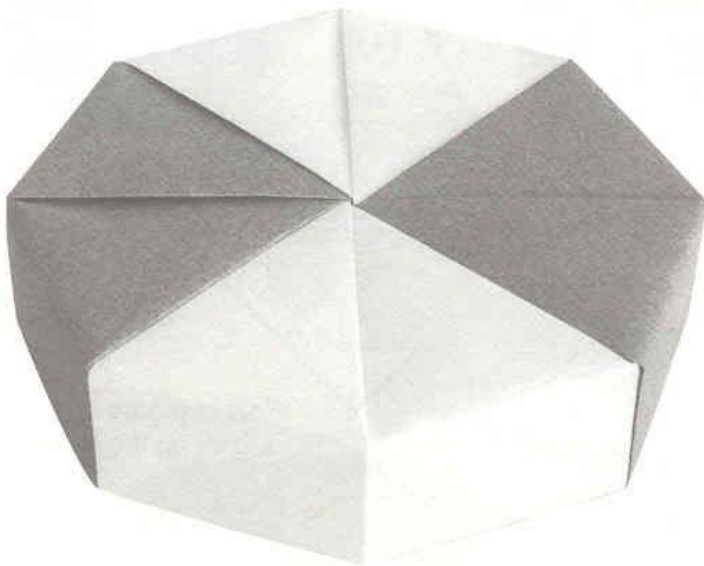

Octagon Box - Plain

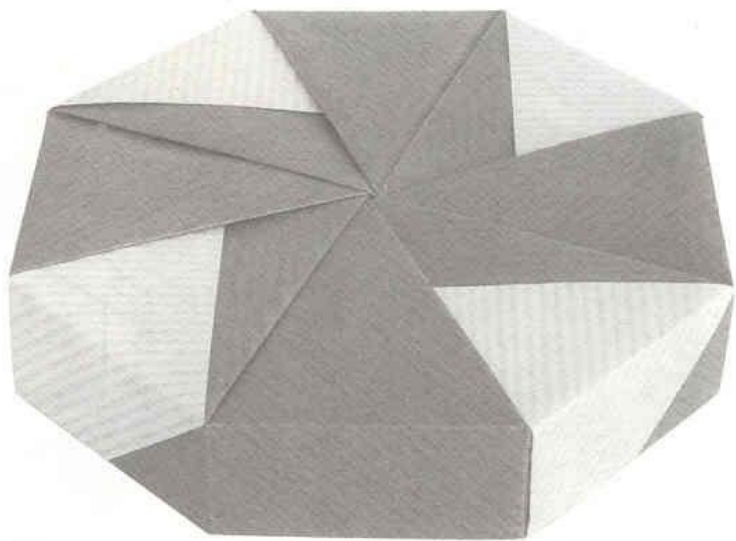

◆ a ◆

Variations of Plain Boxes - a, b, c



a

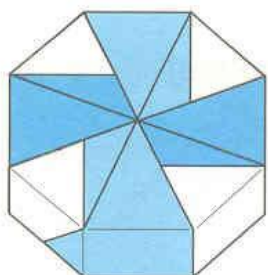
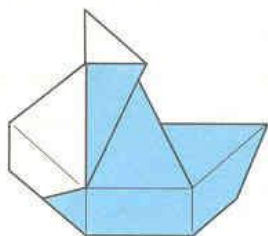

b

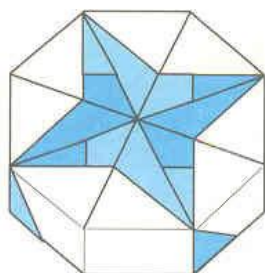
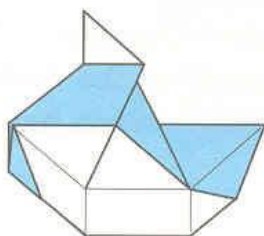

c

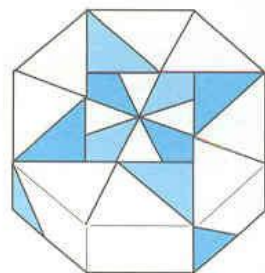
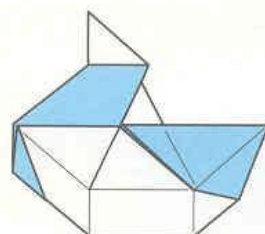

◆ c ◆

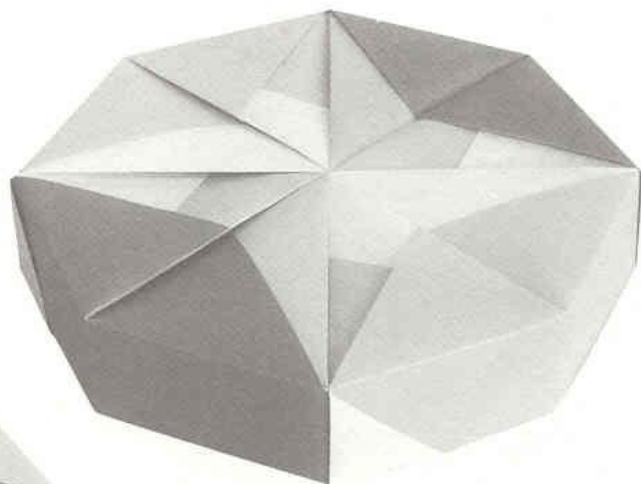

◆ b ◆

Octagon Box Body

The side of the box is decided by length (a) in step ②. Put new paper on the template ③' and take the measurements. When you get used to the folding methods, think out a body which has a twin pattern with the lid.

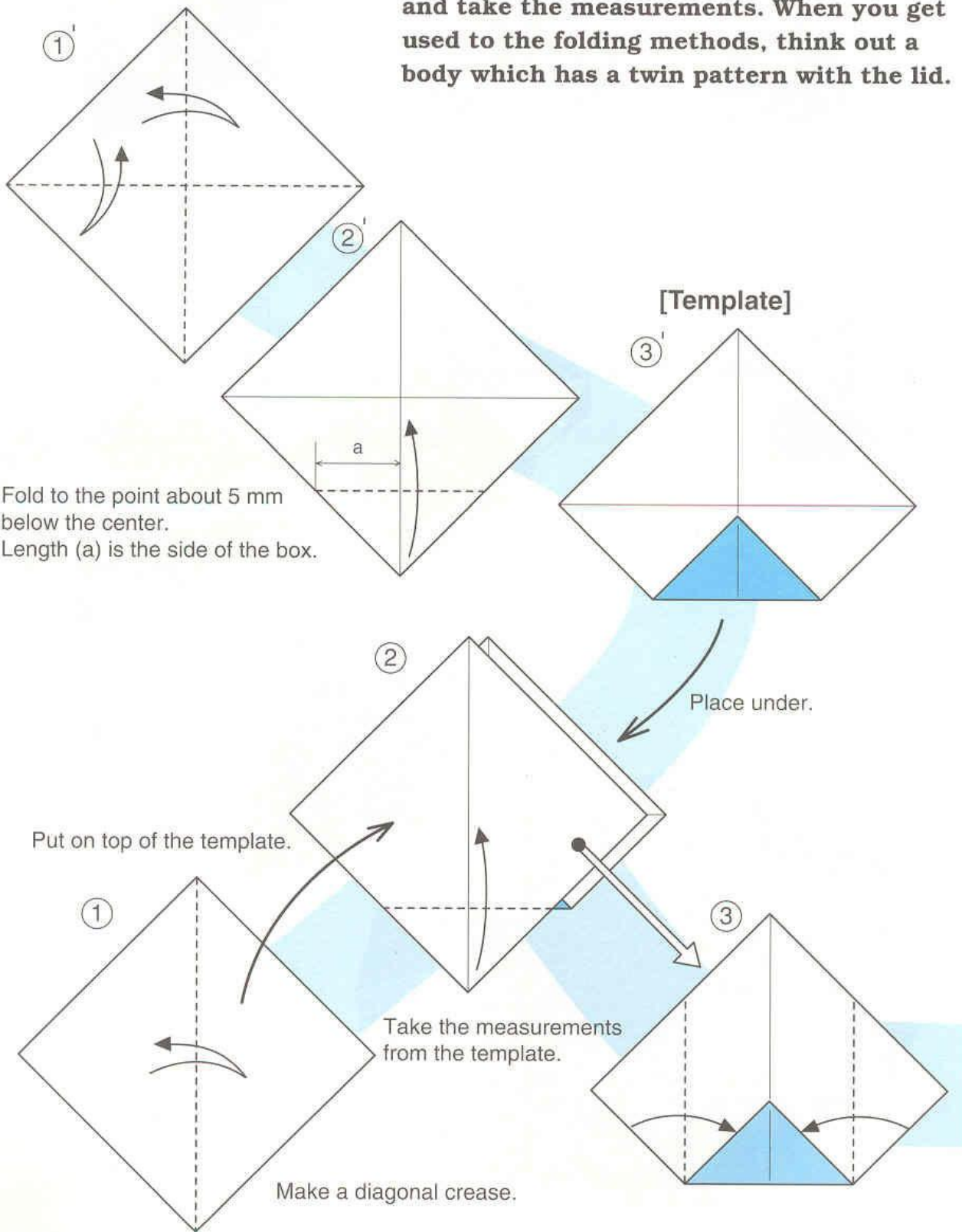

⑪ Unfold after making a crease.

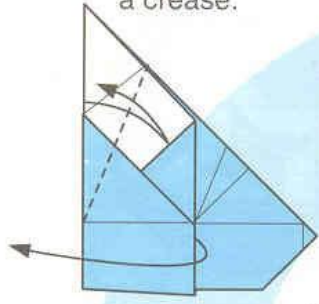

⑫

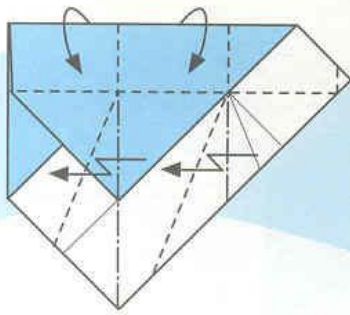

Fold in pleats and lift up the sides.

⑬

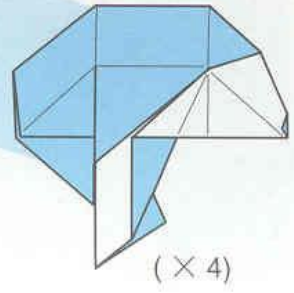

See the next page for assembly. →

⑩

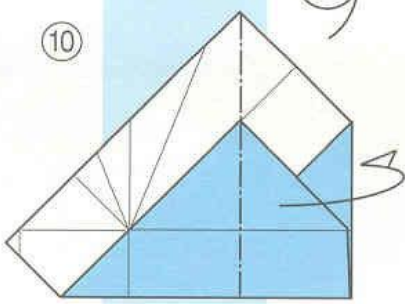

⑨

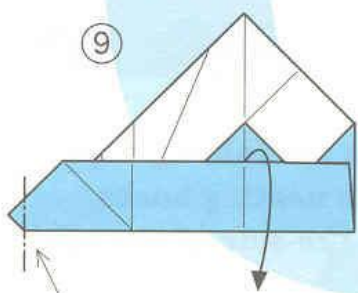

Make a crease to make a small triangle at the end.

⑧

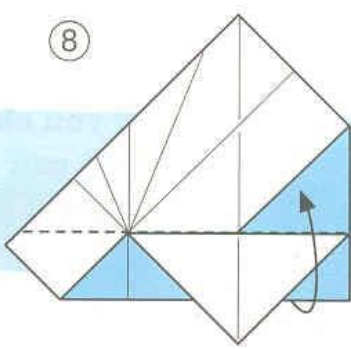

⑦

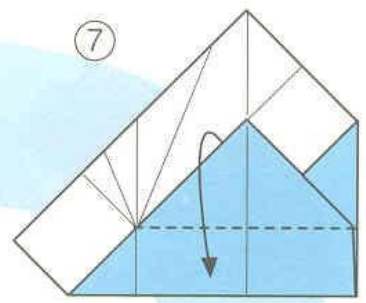

④

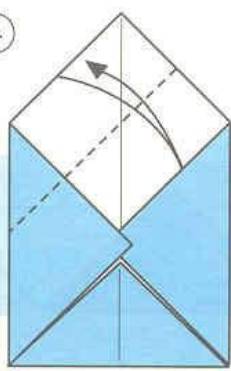

⑤

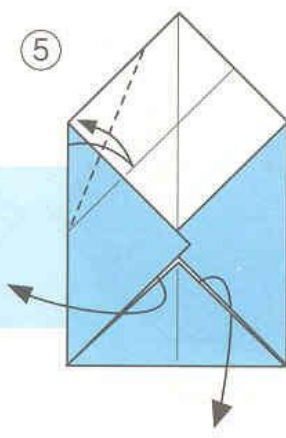

⑥

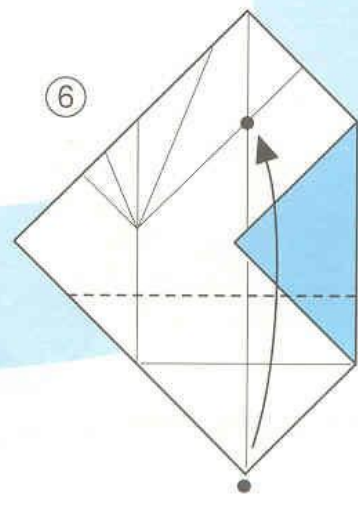

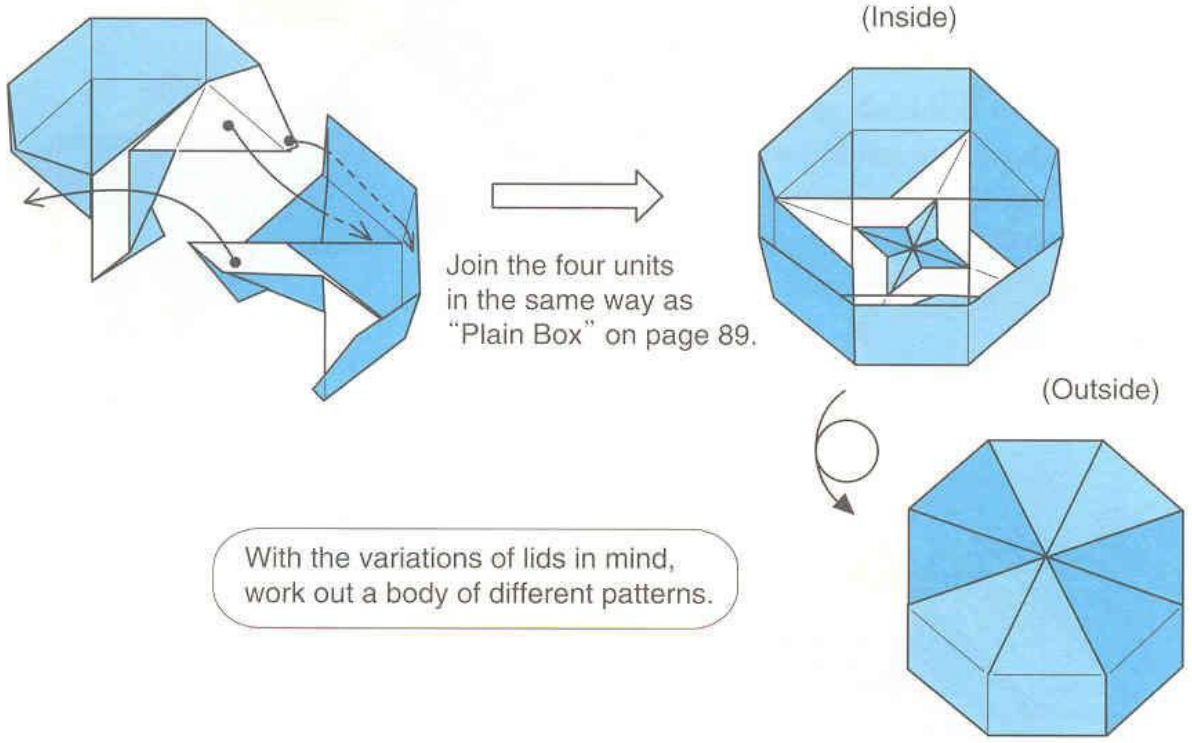

Join the four units in the same way as "Plain Box" on page 89.

With the variations of lids in mind, work out a body of different patterns.

Nesting Octagon Boxes



If you change the folding width of ①, you can make nesting boxes. Length (a) is the side of the box.

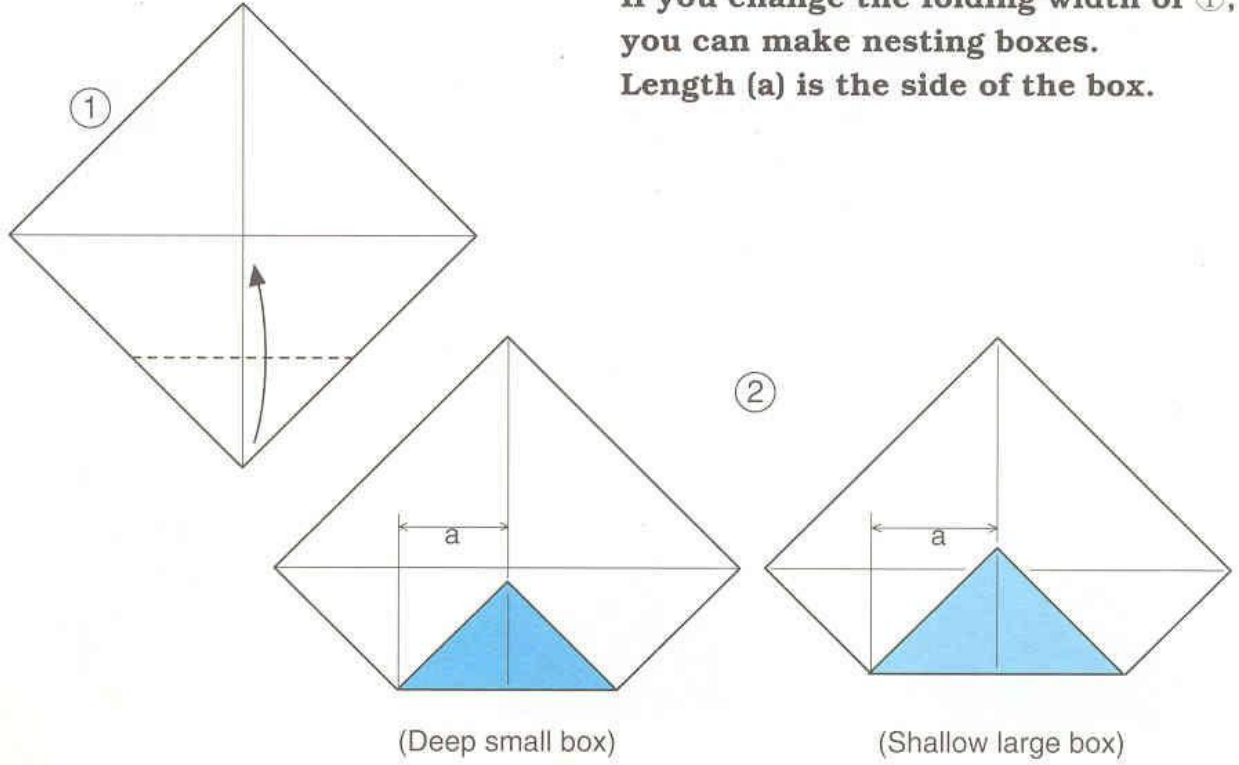

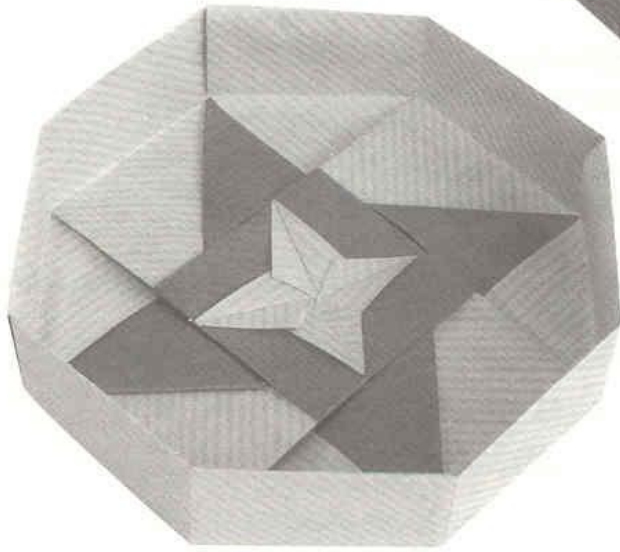

Octagon Box - Body

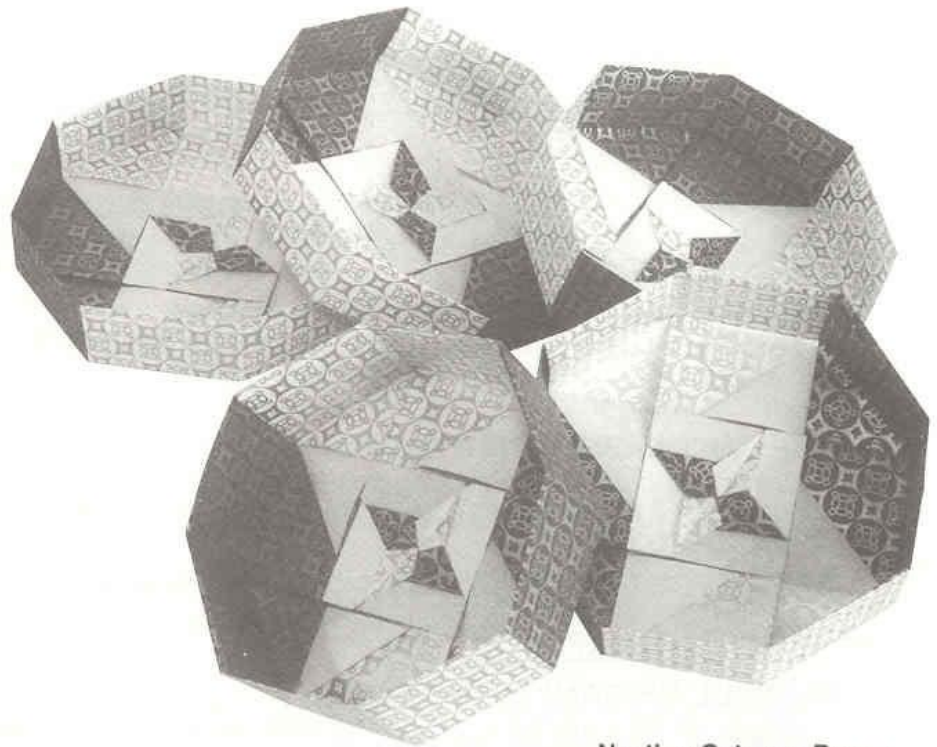
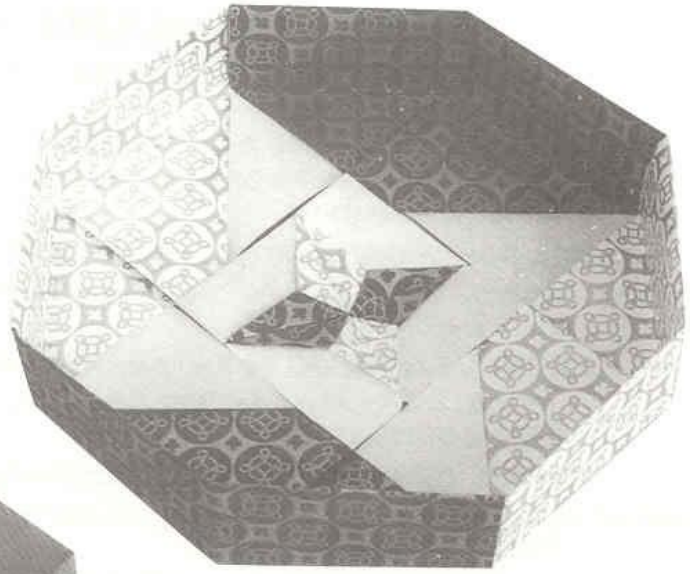

Nesting Octagon Boxes

ORIGAMI BOOKS

from Japan Publications

- BRILLIANT ORIGAMI:** A Collection of Original Designs by David Brill
240 pp., 7 1/4 x 10 1/4 in., 8 pp. color, 215 pp. line drawings, paperback.
ISBN: 0-87040-896-8
- COMPLETE ORIGAMI COLLECTION, THE,** by Toshie Takahama
160 pp., 7 1/4 x 10 1/4 in., 8 pp. color, 147 pp. line drawings, paperback.
ISBN: 0-87040-960-3
- CREATIVE ORIGAMI** by Kunihiko Kasahara
180 pp., 8 1/4 x 11 3/4 in., 8 pp. b/w photos, 160 pp. line drawings, paperback.
ISBN: 0-87040-411-3
- JOYFUL ORIGAMI BOXES** by Tomoko Fuse
96 pp., 7 1/4 x 10 1/4 in., 8 pp. color, 80 pp. line drawings, paperback.
ISBN: 0-87040-974-3
- KUSUDAMA:** Ball Origami by Makoto Yamaguchi
72 pp., 7 1/4 x 10 1/4 in., 8 pp. color, 65 pp. line drawings, paperback.
ISBN: 4-88996-049-X
- MAGIC OF ORIGAMI, THE,** by Alice Gray and Kunihiko Kasahara with cooperation of Lillian Oppenheimer and Origami Center of America
132 pp., 7 1/4 x 10 1/4 in., 122 pp. b/w photos and line drawings, paperback.
ISBN: 0-87040-624-8
- ORIGAMI** by Hideki Sakata
66 pp., 7 1/4 x 10 1/4 in., 66 pp. full color illustrations, paperback.
ISBN: 0-87040-580-2
- ORIGAMI ABC's** by Hideki Sakata
48 pp., 8 1/4 x 10 1/4 in., 2 color line drawings, paperback.
ISBN: 0-87040-999-9
- ORIGAMI ANIMALS** by Keiji Kitamura
88 pp., 8 1/4 x 10 1/4 in., 88 pp. full color illustrations, 12 sheets of origami paper included, paperback.
ISBN: 0-87040-941-7
- ORIGAMI BOXES** by Tomoko Fuse
72 pp., 7 1/4 x 10 1/4 in., 8 pp. color, 60 pp. line drawings, paperback.
ISBN: 0-87040-821-6
- ORIGAMI CLASSROOM I** by Dokuotei Nakano
Boxed set, board-book: 24 pp., 6 x 6 in., 24 pp. full color illustrations, plus origami paper: 6 x 6 in., 54 sheets of rainbow-color paper.
ISBN: 0-87040-912-3
- ORIGAMI CLASSROOM II** by Dokuotei Nakano
Boxed set, board-book: 24 pp., 6 x 6 in., 24 pp. full color illustrations, plus origami paper: 6 x 6 in., 60 sheets of rainbow-color paper.
ISBN: 0-87040-938-7
- ORIGAMI FOR THE CONNOISSEUR** by Kunihiko Kasahara and Toshie Takahama
168 pp., 7 1/4 x 10 1/4 in., 2 color line drawings, paperback.
ISBN: 4-8170-9002-2
- PLAYFUL ORIGAMI** by Reiko Asou
96 pp., 8 1/4 x 10 1/4 in., 48pp. full color illustrations, 10 sheets of origami paper included, paperback.
ISBN: 0-87040-827-5

- ORIGAMI HEARTS** by Francis Ow Mun Yin
120 pp., 7 1/4 x 10 1/4 in., 8 pp. color, 104 pp. line drawings, paperback.
 ISBN: 0-87040-957-3
- ORIGAMI MADE EASY** by Kunihiko Kasahara
128 pp., 6 x 8 1/4 in., 113 pp. b/w photos and line drawings, paperback.
 ISBN: 0-87040-253-6
- ORIGAMI OMNIBUS: Paper-folding for Everybody** by Kunihiko Kasahara
384 pp., 7 1/4 x 10 1/4 in., 8 pp. color, 360 pp. line drawings, paperback.
 ISBN: 4-8170-9001-4
- ORIGAMI TREASURE CHEST** by Keiji Kitamura
80 pp., 8 1/4 x 10 1/4 in., full color, paperback.
 ISBN: 0-87040-868-2
- PAPER MAGIC: Pop-up Paper Craft** by Masahiro Chatani
92 pp., 7 1/4 x 10 1/4 in., 16 pp. color, 72 pp. b/w photos and line drawings, paperback.
 ISBN: 0-87040-757-0
- POP-UP BEST GREETING CARDS** by Keiko Nakazawa
122 pp., 7 1/4 x 10 1/4 in., 16 pp. color, 102 pp. b/w photos and line drawings, paperback.
 ISBN: 0-87040-964-6
- POP-UP GIFT CARDS** by Masahiro Chatani
80 pp., 7 1/4 x 10 1/4 in., 16 pp. color, 64 pp. b/w photos and line drawings, paperback.
 ISBN: 0-87040-768-6
- POP-UP GEOMETRIC ORIGAMI** by Masahiro Chatani and Keiko Nakazawa
86 pp., 7 1/4 x 10 1/4 in., 16 pp. color, 64 pp. b/w photos and line drawings, paperback.
 ISBN: 0-87040-943-3
- POP-UP ORIGAMIC ARCHITECTURE** by Masahiro Chatani
88 pp., 7 1/4 x 10 1/4 in., 4 pp. color, 11 pp. b/w photos, 68 pp. line drawings, paperback.
 ISBN: 0-87040-656-6
- Quick & Easy ORIGAMI** by Toshie Takahama
Boxed set, book: 60 pp., 6 x 4 1/8 in., 30 pp. color and 30 pp. line drawings, origami paper: 3 packs in 6 colors (90 sheets).
 ISBN: 0-87040-771-6
- Quick & Easy FLYING ORIGAMI** by Eiji Nakamura
Boxed set, book: 60 pp., 6 x 4 1/8 in., 30 pp. color and 30 pp. line drawings, origami paper: 3 packs in 6 colors (90 sheets).
 ISBN: 0-87040-925-5
- Quick & Easy ORIGAMI BOXES** by Tomoko Fuse
Boxed set, book: 60 pp., 6 x 4 1/8 in., 30 pp. color and 30 pp. line drawings, origami paper: 3 packs in 6 colors (90 sheets).
 ISBN: 0-87040-939-5
- SIMPLE TRADITIONAL ORIGAMI** by Tomoko Fuse
80 pp., 7 1/4 x 10 1/4 in., 8 pp. color, 68 pp. 2 color line drawings, paperback.
 ISBN: 4-88996-041-4
- UNIT ORIGAMI: Multidimensional Transformations** by Tomoko Fuse
244 pp., 7 1/4 x 10 1/4 in., 8 pp. color, 220 pp. b/w photos and line drawings, paperback.
 ISBN: 0-87040-852-6
- WORLD OF ORIGAMI, THE,** by Isao Honda
182 pp., 8 1/4 x 11 3/4 in., 170 pp. b/w photos and line drawings, paperback.
 ISBN: 0-87040-383-4

US\$17.00

ISBN 0-87040-978-6

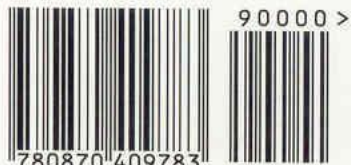

More imaginative designs from our bestselling origami author

Imagine a box made of paper! Boxes are one of the most popular formats of the age-old papercraft of origami. This delightful book is entirely devoted to the creation of origami boxes—plain or fancy, playful or practical, and elaborate boxes topped with cranes, butterflies, lilies, stars, and more.

TITULO:	FABULOUS ORIGAMI BOXES	angle
AUTOR:	FUSE, T.	ailed
FECHA.:	5/05/2001	and
CODIGO:	9780870409783	, but
PRECIO:	19.300,00	

Both practical and lovely, these boxes can be used for gift-giving, storing trinkets, or simply for display.

Tomoko Fuse is a respected member of Origami USA, the British Origami Association, and the Japan Origami Association. She is the author of the best-selling origami books *Origami boxes*, *Unit Origami*, *Quick & Easy Origami Boxes* and *Joyful Origami Boxes*—all from Japan Publications.

Japan Publications

Printed in Japan

FABULOUS ORIGAMI BOXES

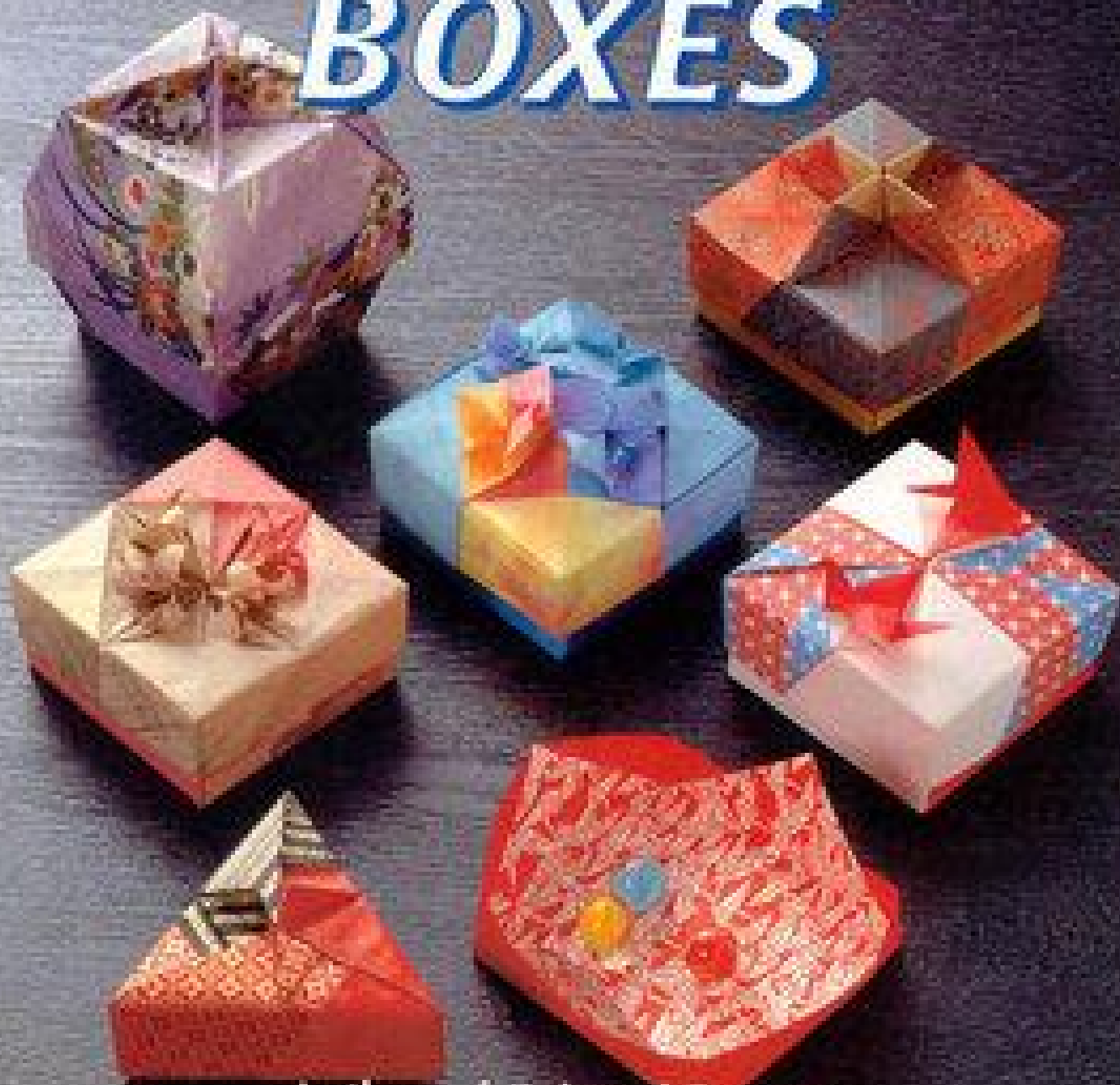

Author of *Origami Boxes*,
Quick & Easy Origami Boxes and *Unit Origami*
TOMOKO FUSE